



# CITY OF ARCADIA

# CITY COUNCIL REGULAR MEETING AGENDA

**Tuesday, June 16, 2026, 6:00 P.M.**

**Location: City Council Chambers, 240 W. Huntington Drive**

Pursuant to the Americans with Disabilities Act, persons with a disability who require a disability related modification or accommodation in order to participate in a meeting, including auxiliary aids or services, may request such modification or accommodation from the City Clerk at (626) 574-5455. Notification 48 hours prior to the meeting will enable the City to make reasonable arrangements to assure accessibility to the meeting.

根据《美国残障人法案》，需要调整或提供便利设施才能参加会议的残障人士（包括辅助器材或服务）可与市书记官办公室联系（电话：(626) 574-5455）。请在会前 48 小时通知市书记官办公室，以便作出合理安排，确保顺利参加会议。

Pursuant to the City of Arcadia's Language Access Services Policy, limited-English proficient speakers who require translation services in order to participate in a meeting may request the use of a volunteer or professional translator by contacting the City Clerk's Office at (626) 574-5455 at least 72 hours prior to the meeting.

根据阿凯迪亚市的语言便利服务政策，英语能力有限并需要翻译服务才能参加会议的人可与市书记官办公室联系（电话：(626) 574-5455），请求提供志愿或专业翻译服务，请至少在会前 72 小时提出请求。

### **How to Submit Public Comment:**

Members of the Public who wish to submit public comment may do so using one of the following methods. Public comment is limited to the time and words allotted.

1. **In-Person:** Complete a Speaker Card, indicating the agenda item number and place it in the Public Comment Drop Box, or simply come to the podium when the Mayor asks for those who wish to speak. Generally, the allotted time is determined by the number of speakers, in accordance with the following format: **5 speakers or less – 5 minutes each**; between **6 and 20 speakers – 3 minutes each**; between **21 and 50 speakers – 2 minutes each**; and more than **50 speakers – 1 minute each**. Comments on all non-public hearing items will generally be taken at the Public Comment portion of the agenda.
2. **Website:** Please submit your comments using our online public comment form at [ArcadiaCA.gov/comment](https://ArcadiaCA.gov/comment). Your comments must be received at least 30 minutes prior to the posted meeting time.
3. **Email:** Please submit your comments via email to [CityClerk@ArcadiaCA.gov](mailto:CityClerk@ArcadiaCA.gov). Your comments must be received at least 30 minutes prior to the posted meeting time.

Electronic submission of Public Comment is also available via the City's website or by email as noted above. Public Comment submitted electronically will not be read into the record at the posted meeting time but are forwarded to the City Council prior to the meeting for consideration.

### 如何提交公众评论意见：

公众成员可以使用以下任何一种方法提交公众评论意见。请在时间和字数的限制范围内提交公众评论意见

1. **现场发言：**填写发言卡，注明议程项目编号并投入公众意见投递箱；或在市长邀请发言者上前时，直接上前至讲台。发言时间通常根据发言人数确定，具体如下：**5**人及以下，**每人 5 分钟**；**6**至**20**人，**每人 3 分钟**；**21**至**50**人，**每人 2 分钟**；超过**50**人，**每人 1 分钟**。所有非公开听证事项的意见通常在议程中的公众意见环节听取。
2. **网站：**请使用以下网站中刊载的在线公众评论意见表提交您的评论意见：[ArcadiaCA.gov/comment](http://ArcadiaCA.gov/comment)。必须在公布的会议时间前至少提前 30 分钟提交评论意见。
3. **电子邮件：**请将您的评论意见通过电子邮件发送至：[CityClerk@ArcadiaCA.gov](mailto:CityClerk@ArcadiaCA.gov)。必须在公布的会议时间前至少提前 30 分钟提交评论意见。

亦可按照以下方法在本市网站上或通过电子邮件以电子方式提交公众评论意见。以电子方式提交的公众评论意见不会在公布的会议期间读入记录，但会在会议开始前转交给市议会，供市议会考虑。

## CALL TO ORDER

## ROLL CALL OF CITY COUNCIL MEMBERS

Paul P. Cheng, Mayor  
David Fu, Mayor Pro Tem  
Dr. Michael Cao, Council Member  
Sharon Kwan, Council Member

## PUBLIC COMMENTS (5-minute time limit each speaker)

Any person wishing to speak before the City Council is asked to complete a Speaker Card and place it in the Public Comment Drop Box prior to the time the Mayor calls for Public Comments. Generally, the allotted time is determined by the number of speakers, in accordance with the following format: **5** speakers or less – **5 minutes each**; between **6** and **20** speakers – **3 minutes each**; between **21** and **50** speakers – **2 minutes each**; and more than **50** speakers – **1 minute each**. Comments on all non-public hearing items will generally be taken at the Public Comment portion of the agenda. Under the Brown Act, the City Council is prohibited from discussing or taking action on any item not listed on the posted agenda.

## OPEN SESSION TO THE PUBLIC

- a. Appointment to fill the unexpired term of City Council Member representing District 3.  
CEQA: Not a Project  
Recommended Action: Make Appointment

## CLOSED SESSION

- a. Pursuant to Government Code Section 54956.9(d)(2) to confer with legal counsel regarding the Workers' Compensation matter of John Twitchell (Claim #20-146485/WCAB Case No. ADJ12892256).

**Regular Meeting  
City Council Chambers, 7:00 p.m.**

**1. CALL TO ORDER**

**2. INVOCATION**

Religious Director Riaz Kahn, Mosque of San Gabriel

**3. PLEDGE OF ALLEGIANCE**

Religious Director Riaz Kahn, Mosque of San Gabriel

**4. ROLL CALL OF CITY COUNCIL MEMBERS**

Paul P. Cheng, Mayor  
David Fu, Mayor Pro Tem  
Dr. Michael Cao, Council Member  
Sharon Kwan, Council Member

**5. REPORT FROM CITY ATTORNEY REGARDING CLOSED/STUDY SESSION ITEMS**

**6. SUPPLEMENTAL INFORMATION FROM CITY MANAGER REGARDING AGENDA ITEMS**

**7. CITY CLERK**

a. Administration of the oath of office to District 3 Council Member.

**8. PRESENTATIONS**

a. Presentation of a \$12,550 donation from the Friends of the Gilb Museum of Arcadia Heritage for programming and supplies.

b. Presentation of a \$50,000 donation from the Friends of the Arcadia Public Library for library programming.

**9. APPOINTMENTS**

a. Appointments to City Boards and Commissions.  
CEQA: Not a Project  
Recommended Action: Make Appointments

**10. PUBLIC HEARING**

Any person wishing to speak before the City Council on a public hearing item is asked to complete a Speaker Card, noting the agenda item number and placing it in the Public Comment Drop Box, prior to the start of the public hearing. Separate and apart from the applicant (who may speak longer in the discretion of the City Council), the allotted time is determined by the number of speakers, in accordance with the following format: **5 speakers or less – 5 minutes each**; between **6 and 20 speakers – 3 minutes each**; between **21 and 50 speakers – 2 minutes each**; and more than **50 speakers – 1 minute each**. Under the Brown Act, the City Council is prohibited from discussing or acting on any item not listed on the posted agenda. The applicant may additionally submit rebuttal comments, at the discretion of the City Council.

You are hereby advised that should you desire to legally challenge in court or in an administrative proceeding any action taken by the City Council regarding any public hearing item, you may be limited to raising only those issues and objections you or someone else raised at the public hearing or in written correspondence delivered to the City Council at, or prior to, the public hearing.

- a. Resolutions relating to the adoption of the Fiscal Year 2026-27 Operating Budget and the Fiscal Years 2026-27 through 2030-31 Capital Improvement and Equipment Plan.

Resolution No. 7696 adopting a Budget for Fiscal Year 2026-27 and appropriating the amounts specified therein as expenditures from the various funds.

CEQA: Not a Project  
Recommended Action: Adopt

Resolution No. 7697 adopting a Capital Improvement and Equipment Plan for Fiscal Years 2026-27 through 2030-31.

CEQA: Not a Project  
Recommended Action: Adopt

- b. Appeal No. 26-01 - a request to overturn the Planning Commission’s Denial of Multi-Family SB 330 Application No. SB 330 25-01, Tentative Tract Map No. TTM 26-01 (84910), and Protected Healthy Tree Removal No. TRH 26-02 for a new 30 unit, multi-family residential condominium development located at 514 Fairview Avenue; and consideration of Resolution No. 7699 - approving Appeal No. 26-01.

CEQA: Exempt  
Recommended Action: Adopt

- c. Reschedule the public hearing for the Fiscal Year 2026-27 Levy and Collection of the Arcadia Citywide Lighting District No. 1.

CEQA: Not a Project  
Recommended Action: Approve

- d. Resolution No. 7700 amending the Residential Refuse and Recycling Agreement with Waste Management and setting refuse and recycling rates for the collection

and disposal of single-family and multi-family residential solid waste and recyclables pursuant to Section 5120.7 of the Arcadia Municipal Code for Fiscal Years 2026-27 through 2030-31.

CEQA: Not a Project

Recommended Action: Adopt

- e. Resolution No. 7702 adopting the City of Arcadia's 2025 Urban Water Management Plan and Water Shortage Contingency Plan.

CEQA: Exempt

Recommended Action: Adopt

## **11. PUBLIC COMMENTS** (5-minute time limit each speaker)

Any person wishing to speak before the City Council is asked to complete a Speaker Card and place it in the Public Comment Drop Box prior to the time the Mayor calls for Public Comments. Generally, the allotted time is determined by the number of speakers, in accordance with the following format: **5 speakers or less – 5 minutes each**; between **6 and 20 speakers – 3 minutes each**; between **21 and 50 speakers – 2 minutes each**; and more than **50 speakers – 1 minute each**. Comments on all non-public hearing items will generally be taken at the Public Comment portion of the agenda. Under the Brown Act, the City Council is prohibited from discussing or taking action on any item not listed on the posted agenda.

## **12. CONSENT CALENDAR**

- a. Regular Meeting Minutes of June 2, 2026.

CEQA: Not a Project

Recommended Action: Approve

- b. Resolution No. 7701 authorizing a supplemental budget appropriation in the amount of \$35,707, from the General Fund Reserve; and approving the Support Agreement renewal for the Power911/VIPER System and Purchase Order for related equipment with AT&T, in an amount not to exceed \$35,707.

CEQA: Not a Project

Recommended Action: Adopt and Approve

- c. Donation from the Friends of the Gilb Museum of Arcadia Heritage for programming and supplies in the amount of \$12,550.

CEQA: Not a Project

Recommended Action: Accept

- d. Donation from the Friends of the Arcadia Public Library for library programming in the amount of \$50,000.

CEQA: Not a Project

Recommended Action: Accept

- e. Professional Services Agreement with Studio Spectrum, Inc. for City Council Meeting broadcast and recording services, from July 1, 2026, through June 30,

2029, in an amount not to exceed \$42,120 per year, with the option of two one-year renewals.

CEQA: Not a Project

Recommended Action: Approve

- f. Professional Services Agreement with Inter-Con Security for official parking enforcement services for a three-year period beginning July 1, 2026, through June 30, 2029, with the option of three, one-year renewals, in an amount not to exceed \$937,596 for the initial three-year period.

CEQA: Not a Project

Recommended Action: Approve

- g. Professional Services Agreement with VRC Companies, LLC for Laserfiche Cloud and Support Services from July 1, 2026, through June 30, 2029, in the amount of \$76,842.20, with the option of two one-year extensions.

CEQA: Not a Project

Recommended Action: Approve

- h. Professional Services Agreement with the Pasadena Humane Society for animal control services in an amount not to exceed \$2,115,648 for a five-year period, beginning July 1, 2026, through June 30, 2031.

CEQA: Not a Project

Recommended Action: Approve

- i. Professional Services Agreement with Mars Printing for Citywide printing services for a five-year term, in an amount not to exceed \$180,000 annually, with the option of two one-year renewals.

CEQA: Not a Project

Recommended Action: Approve

- j. Amendment to the Professional Services Agreement with Executive Information Services, Inc. for PS.NET Public Safety Software System Support Services in the amount of \$53,241.

CEQA: Not a Project

Recommended Action: Approve

- k. Amendment No. 2 to the Professional Services Agreement with Allied Universal Security Services for jail operation services for Fiscal Year 2026-27, in an amount not to exceed \$428,196.

CEQA: Not a Project

Recommended Action: Approve

- l. Amendment No. 5 to the Professional Services Agreement with All City Management Services Inc. for crossing guard services for Fiscal Year 2026-27, in an amount not to exceed \$394,657.

CEQA: Not a Project

Recommended Action: Approve

- m. Agreement for Services with the Arcadia Chamber of Commerce for Fiscal Year 2026-27 in the amount of \$104,367.  
CEQA: Not a Project  
Recommended Action: Approve
- n. Contract with Mission Paving and Sealing, Inc. for the Fiscal Year 2025-26 Annual Slurry Seal Project in the amount of \$754,125.  
CEQA: Exempt  
Recommended Action: Approve
- o. Design-Build Contract with Pacific Hydrotech Corporation for the Peck Well PFAS Treatment System Project in the amount of \$3,204,400.  
CEQA: Exempt  
Recommended Action: Approve
- p. Final Tract Map No. 84785 to consolidate two legal lots as one lot to accommodate a 10-unit residential condominium subdivision at 36 and 42 East Colorado Boulevard.  
CEQA: Exempt  
Recommended Action: Approve
- q. Purchase Order with Zero Infrastructure Mobility Solutions dba Connected Signals for the purchase of Next-Generation Emergency Vehicle Traffic Signal Preemption System services in the amount of \$52,000.  
CEQA: Not a Project  
Recommended Action: Approve
- r. Purchase Order with Tsai Fong for international language materials in an amount not to exceed \$35,000.  
CEQA: Not a Project  
Recommended Action: Approve
- s. Purchase Orders for annual software hosting and maintenance services with Oracle America for NetSuite for Government and Can/Am Technologies for Teller cashiering, in an amount not to exceed \$177,900.  
CEQA: Not a Project  
Recommended Action: Approve
- t. Purchase Order with Netsync, Inc. for Pure Storage annual maintenance and support in the amount of \$43,489.  
CEQA: Not a Project  
Recommended Action: Approve
- u. Purchase Order with OCLC, Inc. for bibliographic services and metadata in an amount not to exceed \$32,000.  
CEQA: Not a Project  
Recommended Action: Approve

- v. Purchase Order with OverDrive, Inc. for eBooks, eMagazines, digital audiobooks, and streaming videos in an amount not to exceed \$80,000.

CEQA: Not a Project

Recommended Action: Approve

- w. Amendment to the Professional Services Agreement with Jones-Walbaum Corporation dba American Business Machines for fire alarm and fire suppression repairs, and additional access control panels, cameras, and equipment in the amount of \$384,398.38.

CEQA: Not a Project

Recommended Action: Approve

### **13. CITY MANAGER**

- a. Resolutions to reorganize the Public Works Services Department.

Resolution No. 7703 amending Resolution No. 7598, establishing compensation and related benefits for City Council, Executive Management, Management, and Unrepresented Confidential employees for July 1, 2024, through June 30, 2027 (Assistant City Manager/Public Works Services Director; City Engineer/Deputy Public Works Services Director; Deputy Public Works Services Director - Administration; Utilities Manager; Deputy Development Services Director).

CEQA: Not a Project

Recommended Action: Adopt

Resolution No. 7704 amending Resolution No. 7594, approving a Memorandum of Understanding establishing compensation and related benefits for employees represented by the Arcadia City Employees' Association ("ACEA") for July 1, 2024, through June 30, 2027 (Arborist).

CEQA: Not a Project

Recommended Action: Adopt

### **14. AB 1234 REPORTS FROM MAYOR AND CITY COUNCIL (*limited to legally required reports*).**

### **15. REQUEST FOR FUTURE ITEMS**

### **16. ADJOURNMENT**

The City Council will adjourn this meeting to Tuesday, July 21, 2026, at 6:00 p.m. in the City Council Conference Room.

## Welcome to the Arcadia City Council Meeting!

The City Council encourages public participation, and invites you to share your views on City business.

**MEETINGS:** Regular Meetings of the City Council are held on the first and third Tuesday of each month at 7:00 p.m. in City Council Chambers. A full City Council agenda packet with all backup information is available at City Hall and on the City's website at [www.ArcadiaCA.gov](http://www.ArcadiaCA.gov). Copies of individual Agenda Reports are available via email upon request ([CityClerk@ArcadiaCA.gov](mailto:CityClerk@ArcadiaCA.gov)). Documents distributed to a majority of the City Council after the posting of this agenda will be available for review at the Office of the City Clerk, 240 W. Huntington Drive, Arcadia, California. Live broadcasts and replays of the City Council Meetings are on cable television. Your attendance at this public meeting may result in the recording and broadcast of your image and/or voice as previously described.

**PUBLIC PARTICIPATION:** Your participation is welcomed and invited at all City Council meetings. Time is reserved at each regular meeting for those in the audience who wish to address the City Council. The City requests that persons addressing the City Council refrain from making personal, slanderous, profane, or disruptive remarks. Where possible, please place a **Speaker Card** in the Public Comment Drop Box, or simply come to the podium when the Mayor asks for those who wish to speak, and state your name and address (optional) for the record.

**PUBLIC COMMENTS:** Should be presented during the time designated as "PUBLIC COMMENTS", for all matters on the agenda or not on the agenda. **By State law, the City Council may not discuss or vote on items not on the agenda. The matter may be referred to staff for appropriate action or response or will be placed on the agenda of a future meeting except for public hearing items.**

**PUBLIC HEARINGS AND APPEALS:** Are items scheduled for which public input is either required or desired. Separate and apart from the applicant (who may speak longer in the discretion of the City Council), the allotted speaking time is generally determined by the number of speakers, in accordance with the following format: **5 speakers or less – 5 minutes each**; between **6 and 20 speakers – 3 minutes each**; between **21 and 50 speakers – 2 minutes each**; and more than **50 speakers – 1 minute each**. The applicant may additionally submit rebuttal comments.

**AGENDA ITEMS:** The Agenda contains the regular order of business of the City Council. Items on the Agenda have generally been reviewed and investigated by the City Staff in advance of the meeting so that the City Council can be fully informed about a matter before making its decision.

**CONSENT CALENDAR:** Items listed on the Consent Calendar are considered to be routine by the City Council and will be acted upon by one motion. There will be no separate discussion on these items unless a member of the City Council, Staff, or the public so requests. In this event, the item will be removed from the Consent Calendar and considered and acted on separately.

**DECORUM:** While members of the public are free to level criticism of City policies and the action(s) or proposed action(s) of the City Council or its members, members of the public may not engage in behavior that is disruptive to the orderly conduct of the proceedings, including but not limited to, conduct that prevents other members of the audience from being heard when it is their opportunity to speak or which prevents members of the audience from hearing or seeing the proceedings. Members of the public may not threaten any person with physical harm or act in a manner that may reasonably be interpreted as an imminent threat of physical harm. All persons attending the meeting are expected to adhere to the City's policy barring harassment based upon a person's race, religious creed, color, national origin, ancestry, physical handicap, medical condition, marital status, gender, sexual orientation, or age. The Chief of Police, or such member or members of the Police Department, shall serve as the Sergeant-at-Arms of the City Council meeting. The Sergeant-at-Arms shall carry out all orders and instructions given by the presiding official or a majority of the Councilmembers, for the purpose of maintaining order and decorum at the meeting. Any person who violates the order and decorum of the meeting may be placed under arrest and such person may be prosecuted under the provisions of Penal Code Section 403 or applicable Arcadia Municipal Code section.

## 欢迎参加阿凯迪亚市议会会议！

市议会鼓励公众参与，欢迎您就市政事务分享观点。

**会议：** 市议会例行会议于每月第一个和第三个星期二晚 7:00 在市议会议事厅举行。完整的市议会议程资料包（含所有背景信息）可在市政厅和市网站 [www.ArcadiaCA.gov](http://www.ArcadiaCA.gov) 获取。如有需要，可通过电子邮件 ([CityClerk@ArcadiaCA.gov](mailto:CityClerk@ArcadiaCA.gov)) 索取单项议程报告副本。本议程公布后分发给多数市议会成员的文件，可在市书记官办公室查阅，地址为 240 W. Huntington Drive, Arcadia, California。市议会会议将通过有线电视直播和重播。您出席本次公开会议，您的影像和/或声音可能如前所述被录制和播放。

**公众参与：** 欢迎您参加所有市议会会议。每次例行会议均为希望在市议会发言的与会者预留时间。市府要求在市议会发言的人士避免发表人身攻击、诽谤、亵渎或扰乱秩序的言论。请尽可能将**发言卡**投入公众意见投递箱，或在市长邀请发言者上前时直接上前至讲台，并报上姓名和地址（可选）以供记录。

**公众意见：** 所有关于议程内或议程外事项的意见，均应在指定的“公众意见”环节提出。**根据州法律，对于未列入议程的项目，市议会不得予以讨论或投票表决。相关事宜可转交工作人员采取适当行动或做出回应，或列入未来会议议程，公开听证事项除外。**

**公开听证和上诉：** 这些是已列入议程、需要或希望听取公众意见的项目。除申请人外（市议会可酌情允许其发言更长时间），发言时间通常根据人数确定，具体如下：**5 人及以下，每人 5 分钟；6 至 20 人，每人 3 分钟；21 至 50 人，每人 2 分钟；超过 50 人，每人 1 分钟。** 申请人可另外提交反驳意见。

**议程项目：** 议程包含市议会的常规议事顺序。议程上的项目通常已由市府工作人员在会前进行审查和调查，以便市议会在决策前充分了解相关事项。

**同意议程：** 同意议程上的项目被市议会视为常规事项，将通过一次动议进行表决。除非市议会成员、工作人员或公众提出要求，否则不会对这些项目单独讨论。若有此要求，该项目将从同意议程中移除，并另行审议和表决。

**会场秩序：** 公众可自由批评市政政策以及市议会或其成员的行动或拟议行动，但不得有扰乱会议正常进行的行为，包括但不限于：妨碍其他与会者在发言时被听见，或妨碍其他与会者听见或看见会议进程。公众不得以人身伤害威胁任何人，或以任何可合理解读为迫在眉睫的人身伤害威胁的方式行事。所有与会者均须遵守市府禁止基于种族、宗教信仰、肤色、国籍、血统、身体残疾、健康状况、婚姻状况、性别、性取向或年龄进行骚扰的政策。警察局长或其指定的警局成员担任市议会会议的秩序官。秩序官须执行会议主持官员或多数议员下达的命令和指示，以维持会场秩序和礼仪。任何违反会场秩序和礼仪的人员可能被逮捕，并根据《刑法》第 403 节或适用的《Arcadia 市政法典》条款被起诉。

**DATE:** June 16, 2026

**TO:** Honorable Mayor and City Council

**FROM:** Dominic Lazzaretto, City Manager  
By: Justine Bruno, Deputy City Manager

**SUBJECT:** APPOINTMENT TO FILL THE UNEXPIRED TERM OF CITY COUNCIL MEMBER REPRESENTING DISTRICT 3  
**CEQA: Not a Project**  
**Recommendation: Make Appointment**

**SUMMARY**

On May 11, 2026, a vacancy occurred in City Council District 3 with the resignation of Eileen Wang. At its May 19, 2026, meeting, the City Council directed the City Manager to solicit applications for appointment to fill the unexpired term, with applications due to the City Clerk’s Office by 11:59 p.m. on Friday, May 29.

Before the deadline, 11 applications were referred to the City Council as meeting the eligibility requirements. Before interviews were held during the June 2 Special Meeting, five applicants withdrew from the process. On June 2, the six remaining candidates were interviewed, but no selection was made. It is recommended that the City Council make an appointment to fill the unexpired term in District 3.

**BACKGROUND**

In November 2022, Eileen Wang was elected to the Arcadia City Council by District 3 voters and held office until her resignation on May 11, 2026. Ms. Wang’s resignation from the Arcadia City Council creates a vacancy in District 3 for the balance of the term, which is set to expire upon the certification of the November General Municipal Election results.

At its May 19, 2026, meeting, the City Council considered available options to fill the vacant City Council seat for District 3, determining that an appointment process was the most efficient option to fill the vacancy. During this meeting, the City Council also established the process for filling the vacancy in District 3, including questions to appear on the application, the interview process, and the point system to be followed to rank candidates.

Beginning at 5:00 p.m. on June 2, six prospective applicants gathered in the Council Chambers to be interviewed for the District 3 City Council vacancy. All applicants met the eligibility requirements for City Council service and were verified as registered voters of District 3. Each candidate was given an opportunity to provide opening remarks, followed by questions from the City Council.

At the conclusion of the Special Meeting, the City Council had not yet concluded its deliberations or ranked the candidates. As a result, the item was tabled until the Regular Meeting that evening, beginning at 7:00 p.m. Although the appointment process was briefly revisited during the Regular Meeting, the City Council ultimately continued the item to the June 16 meeting to allow more time for discussion and to make an appointment.

## **DISCUSSION**

By the May 29 deadline, 11 applications were referred to the City Council as meeting the eligibility requirements. Before the interviews began on June 2, five candidates withdrew from the process, leaving six candidates to interview:

- Walter Besocke
- John Han
- Cynthia Ng Monje
- Beth Szymkowski
- Paul Van Fleet
- Lisa Walton

The materials for the remaining applicants are included as Attachment No. 1.

It is recommended that the City Council make an appointment to fill the unexpired term in District 3, concluding upon the certification of the November 3 General Municipal Election results.

### **ENVIRONMENTAL ANALYSIS**

The proposed appointment does not constitute a project under the California Environmental Quality Act ("CEQA"), as it can be seen with certainty that it will have no impact on the environment.

### **FISCAL IMPACT**

The fiscal impacts of selecting a new member of the City Council through an appointment process are negligible. Associated costs include staff time to update records and publications, provide training and onboarding, and purchase the necessary name plates and badges, business cards, and stationery. None of the expenses generated through an appointment process will require a supplemental budget appropriation and can be absorbed within existing budgets.

### **RECOMMENDATION**

It is recommended that the City Council determine that this action is not a project under the California Environmental Quality Act ("CEQA"); and make an appointment to fill the unexpired term in District 3.

Attachment No. 1: District 3 Vacancy - City Council Applications - UPDATED

Name	Comments
Walter Besocke	
John Han	
Cynthia Ng Monje	
Beth Szymkowski	
Paul Van Fleet	
Lisa Walton	

Ruby Chang – **Withdrew Application**

Gail Littlejohn – **Withdrew Application**

Eduardo Magallanes – **Withdrew Application**

William Wu – **Withdrew Application**

Peter Yoo – **Withdrew Application**



# District 3 City Council Vacancy Appointment Application

RECEIVED

MAY 28 2026

CITY OF ARCADIA  
CITY CLERK

\*\*\*\*PLEASE READ CAREFULLY AND COMPLETE THE APPLICATION IN FULL\*\*\*\*

The City of Arcadia is seeking applicants to fill the unexpired term for Arcadia City Council District 3. Complete applications must be submitted to [CityClerk@ArcadicaCA.gov](mailto:CityClerk@ArcadicaCA.gov) by Friday, May 29, 2026, at 11:59 p.m. Applicants considered for appointment must be available for interview by the City Council at a Special Meeting on Tuesday, June 2, 2026, at 5:00 p.m. in the City Council Chambers located at 240 W. Huntington Drive, Arcadia, CA 91007.

All submissions will receive a confirmation email. For questions regarding this application or the appointment process, please contact the City Clerk's Office at (626) 574-5455.

.....

NAME Besocke Walter DATE OF BIRTH [REDACTED]  
LAST FIRST

RESIDENTIAL ADDRESS [REDACTED] Arcadia, CA 91007  
(Note: Cannot be a mailing address or PO Box)

I CERTIFY THAT I AM A RESIDENT OF DISTRICT THREE (3)  YES  NO

PHONE NUMBER [REDACTED] EMAIL ADDRESS [REDACTED]

EMPLOYER Ford Motor Co. OCCUPATION Manager

HOW LONG HAVE YOU BEEN A RESIDENT? 49 years ARE YOU AN ARCADIA REGISTERED VOTER?  YES  NO

.....

PLEASE ANSWER THE QUESTIONS BELOW. YOU MAY USE ADDITIONAL SHEETS OF PAPER AS NECESSARY.

**WHY ARE YOU INTERESTED IN SERVING ON THE ARCADIA CITY COUNCIL?**

I am interested in serving on the Arcadia City Council because Arcadia is more than just the city where I live — it is the community that shaped my life and the place my family proudly calls home. I was born at Huntington Memorial Hospital and, except for three years away, I have spent the last 49 years living in Arcadia. I attended Hugo Reid Elementary School, Foothills Junior High, and Arcadia High School, experiences that gave me a deep appreciation for this community and the strong values that make Arcadia such a special place to live and raise a family. Over the years, I have seen our city grow and evolve, and I believe this is an important time for thoughtful, community-focused leadership.

Like many residents, I care deeply about maintaining the quality of life that makes Arcadia special. Residents are increasingly concerned about issues such as traffic congestion, public safety, infrastructure maintenance, water and utility costs, responsible development, and preserving the character of our neighborhoods. I want to help ensure that Arcadia continues to be a safe, financially stable, and welcoming community for families, seniors, and future generations.

Service has always been an important part of my life. I currently serve in leadership with the Tournament of Roses as Vice Chair of the Parade Operations Committee, where I work with large teams, coordinate complex operations, and solve problems in high-pressure situations. I am also a proud 19-year member of the Arcadia Elks Lodge, where community service and supporting local residents are central to our mission.

Continued on next page.

**WHAT MOST QUALIFIES YOU FOR CITY COUNCIL SERVICE?**

What most qualifies me for service on the Arcadia City Council is my combination of professional management experience, proven leadership in community organizations, and lifelong understanding of the needs and priorities of Arcadia residents.

Professionally, I serve as a manager with Ford Motor Company, where I have developed extensive experience leading teams, managing operations, working within budgets, and making practical decisions in fast-paced environments. My career has taught me how to solve problems, communicate effectively, and balance competing priorities while remaining accountable and results-oriented – skills that are directly relevant to effective local government.

Beyond my professional background, I have spent many years actively involved in volunteer and community leadership. As Vice Chair of the Parade Operations Committee for the Tournament of Roses, I help oversee large-scale logistical planning and coordinate volunteers for one of the nation’s most recognized events. That role requires organization, teamwork, and the ability to make sound decisions under pressure.

I also previously served as President of my homeowners association, where I gained firsthand experience working through neighborhood concerns, addressing infrastructure and maintenance issues, balancing budgets, and listening carefully to residents with differing perspectives. That experience gave me a deeper appreciation for how important transparency, responsiveness, and fiscal responsibility are in serving a community effectively.

Having lived in Arcadia for nearly five decades, I understand both the strengths of our city and the challenges we currently face. Residents want leadership that will prioritize public safety, address increasing traffic and development concerns, maintain city infrastructure, support local businesses, and protect the residential character that makes Arcadia unique. I believe my experience in management, operations, community leadership, and consensus-building has prepared me to approach those issues thoughtfully and responsibly.

Continued on next page.

**CITY COUNCIL MEETINGS ARE ON THE FIRST AND THIRD TUESDAY OF EACH MONTH. I AM AWARE OF THE TIME COMMITMENT AND CAN FULFILL THE OBLIGATIONS OF AN APPOINTMENT TO THE CITY COUNCIL.**

YES  NO

**STATE LAW AND THE CITY CONFLICT OF INTEREST CODE REQUIRES CITY COUNCIL MEMBERS TO FILE A STATEMENT OF ECONOMIC INTERESTS (FORM 700) ANNUALLY AS WELL AS RELATED FORMS WHEN ASSUMING AND LEAVING OFFICE (e.g. sources of income, loans, gifts, investments, interest in real property as required by state law).**

**DO YOU AGREE TO FILE ALL REQUIRED FORMS IN A TIMELY MANNER AS REQUIRED BY THE CITY’S FILING OFFICIAL?**

YES  NO

Email Your Completed Application To:

[CityClerk@ArcadiaCA.gov](mailto:CityClerk@ArcadiaCA.gov)

Questions? Please contact us at (626) 574-5455

**REMINDER: THE DEADLINE TO SUBMIT YOUR APPLICATION IS FRIDAY, MAY 29, 2026, BY 11:59 P.M.**

**I HEREBY CERTIFY THAT THE FOREGOING INFORMATION IS TRUE AND CORRECT TO THE BEST OF MY KNOWLEDGE.**

[Redacted Signature]

SIGNATURE

5/26/2026

DATE

**NOTE:** The City of Arcadia reserves the right to use the information provided on this application to verify your residential address and voter registration status. The information provided on this application is for internal use only and confidential information will not be released to the public.

**Continued from Question 1:**

In addition, I previously served as President of my homeowners association, where I worked directly with residents to address concerns, build consensus, and make decisions that balanced differing viewpoints while protecting the interests of the community. Those experiences reinforced the importance of listening, transparency, accountability, and respectful leadership.

I want to serve on the City Council because I believe local government works best when leaders are approachable, engaged, and willing to listen to the people they represent. I would be honored to give back to the city that has given so much to me by working collaboratively to address today's challenges while preserving the values and sense of community that make Arcadia such a wonderful place to live.

**Continued from Question 2:**

Most importantly, I believe City Council members should be accessible, level-headed, and committed to serving the entire community. I would bring a practical, collaborative approach focused on protecting Arcadia's quality of life while planning responsibly for the future.



# Council District 3

City of Arcadia, California





# District 3 City Council Vacancy Appointment Application

RECEIVED  
CITY OF ARCADIA  
MAY 28 2026  
CITY MANAGER

\*\*\*\*PLEASE READ CAREFULLY AND COMPLETE THE APPLICATION IN FULL\*\*\*\*

The City of Arcadia is seeking applicants to fill the unexpired term for Arcadia City Council District 3. Complete applications must be submitted to [CityClerk@ArcadicaCA.gov](mailto:CityClerk@ArcadicaCA.gov) by **Friday, May 29, 2026, at 11:59 p.m.** Applicants considered for appointment must be available for interview by the City Council at a Special Meeting on **Tuesday, June 2, 2026, at 5:00 p.m.** in the City Council Chambers located at 240 W. Huntington Drive, Arcadia, CA 91007.

All submissions will receive a confirmation email. For questions regarding this application or the appointment process, please contact the City Clerk's Office at (626) 574-5455.

\*\*\*\*\*

NAME Han John DATE OF BIRTH [REDACTED]

LAST FIRST

RESIDENTIAL ADDRESS [REDACTED] Arcadia, CA 91007

(Note: Cannot be a mailing address or PO Box)

I CERTIFY THAT I AM A RESIDENT OF DISTRICT THREE (3)  YES  NO

PHONE NUMBER [REDACTED] EMAIL ADDRESS [REDACTED]

EMPLOYER Self-Employed OCCUPATION Investment Management

HOW LONG HAVE YOU BEEN A RESIDENT? 10 ARE YOU AN ARCADIA REGISTERED VOTER?  YES  NO

\*\*\*\*\*

PLEASE ANSWER THE QUESTIONS BELOW. YOU MAY USE ADDITIONAL SHEETS OF PAPER AS NECESSARY.

WHY ARE YOU INTERESTED IN SERVING ON THE ARCADIA CITY COUNCIL?

Please see attached sheets.

**WHAT MOST QUALIFIES YOU FOR CITY COUNCIL SERVICE?**

Please see attached sheets.

**CITY COUNCIL MEETINGS ARE ON THE FIRST AND THIRD TUESDAY OF EACH MONTH. I AM AWARE OF THE TIME COMMITMENT AND CAN FULFILL THE OBLIGATIONS OF AN APPOINTMENT TO THE CITY COUNCIL.**

YES  NO

**STATE LAW AND THE CITY CONFLICT OF INTEREST CODE REQUIRES CITY COUNCIL MEMBERS TO FILE A STATEMENT OF ECONOMIC INTERESTS (FORM 700) ANNUALLY AS WELL AS RELATED FORMS WHEN ASSUMING AND LEAVING OFFICE (e.g. sources of income, loans, gifts, investments, interest in real property as required by state law).**

**DO YOU AGREE TO FILE ALL REQUIRED FORMS IN A TIMELY MANNER AS REQUIRED BY THE CITY'S FILING OFFICIAL?**

YES  NO

**Email Your Completed Application To:**

[CityClerk@ArcadiaCA.gov](mailto:CityClerk@ArcadiaCA.gov)

**Questions? Please contact us at (626) 574-5455**

**REMINDER: THE DEADLINE TO SUBMIT YOUR APPLICATION IS FRIDAY, MAY 29, 2026, BY 11:59 P.M.**

I HEREBY CERTIFY  ON IS TRUE AND CORRECT TO THE BEST OF MY KNOWLEDGE.

May 28, 2026

DATE

**NOTE: The City of Arcadia reserves the right to use the information provided on this application to verify your residential address and voter registration status. The information provided on this application is for internal use only and confidential information will not be released to the public.**

# John Han - District 3 City Council Vacancy Appointment Application

## WHY ARE YOU INTERESTED IN SERVING ON THE ARCADIA CITY COUNCIL?

Mayor Cheng, Mayor Pro Tem Fu, Council Member Kwan, and Council Member Cao. My name is John Han and I appreciate this opportunity to present my case to fill the vacancy in District 3 of Arcadia.

I have been an Arcadia resident for the past 10 years. On a daily basis, I, along with my dog, walk the avenues and streets of Arcadia. From residential neighborhoods to commercial areas, I have always admired how accessible, welcoming, and thoughtfully designed our community is. These daily walks have given me an intimate understanding of our city's strengths and the areas where we can continue to improve.

Throughout the years, I have seen changes in demographics, businesses, neighborhoods, and the overall character of our beloved city. I have witnessed small businesses open their doors with hopes and determination. I have seen families move into and grow with the city as they set roots here. These transformations remind me that Arcadia is a vibrant community that requires thoughtful stewardship and engaged leadership.

Having worked and lived in numerous cities across the US, Asia, and Europe, my perspectives are as diverse as the residents here. Arcadia is where I chose to settle. Arcadia is where I chose to call home. I recognize something special here, a unique blend of suburban tranquility, cultural richness, excellence in education, and a genuine sense of neighborly connection that only exists in Arcadia.

Recent challenges have tested Arcadia's reputation. But we are resilient and determined to restore the public's trust.

My values are aligned with yours: to move forward with integrity, transparency, accountability, fairness, and empathy. I am committed to uphold the excellence our city council and employees, past and present, have built.

## WHAT MOST QUALIFIES YOU FOR CITY COUNCIL SERVICE?

Beyond shared values, my qualifications complement yours. I have extensive experience in investment management, finance/accounting, and management consulting.

In investment management, I managed portfolios in the hundreds of millions of dollars; making strategic allocation decisions and navigating complex market conditions to deliver consistent returns.

In finance/accounting, I conducted budgeting, forecasting, and audits for multi-billion dollar corporations; ensuring fiscal discipline and providing leadership with actionable financial insights.

In management consulting, I advised organizations on operational efficiency, strategic planning, and organizational restructuring; analyzing complex problems, identifying practical solutions, and implementing changes that deliver measurable results.

My academic foundation, degrees from INSEAD and Tsinghua University, two highly respected academic institutions in the world, is complemented by highly relevant professional credentials:

## John Han - District 3 City Council Vacancy Appointment Application

- Chartered Financial Analyst (CFA) – Underscoring my expertise in investment analysis, portfolio management, and ethical standards in finance
- Project Management Professional (PMP) – Demonstrating my proficiency in leading projects, managing resources, and delivering results on time and within budget
- Certified Information Systems Auditor (CISA) – Providing me with expertise in information systems governance, security, and audit controls

These credentials require hundreds of hours of study, examination, professional development, and ongoing commitment to strict ethical standards emphasizing integrity, objectivity, and accountability.

In addition to my professional qualifications, I have dedicated my time to leadership roles that mirror the responsibilities of public service:

- President, Homeowners Association – Managing community affairs, mediating neighbor concerns, and overseeing budgets for shared spaces
- President, Alumni Association – Building networks, organizing events, and fostering connections among members
- Fintech Committee Member, CFA Society Los Angeles – Contributing to industry dialogue on artificial intelligence, emerging financial technologies, and quantitative strategies
- Chair, CMT Association Los Angeles – Organizing events in systematic investing, promoting ethical standards, and mentoring aspiring practitioners

These volunteer commitments have taught me the importance of listening to diverse stakeholders, building consensus, and serving others without expectation of recognition.

Similarly, I am not seeking this position for personal gain or political ambition. I am seeking it because I believe my skills, experience, and love for this community can make a meaningful difference for the residents of Arcadia. An opportunity to strengthen a place I call home.

I humbly ask for your consideration. Serving on the Arcadia City Council would be both an honor and a responsibility I take seriously. I want to keep Arcadia the kind of place where families set roots, businesses prosper, and a daily walk through our avenues and streets still feels like home.

Thank you.

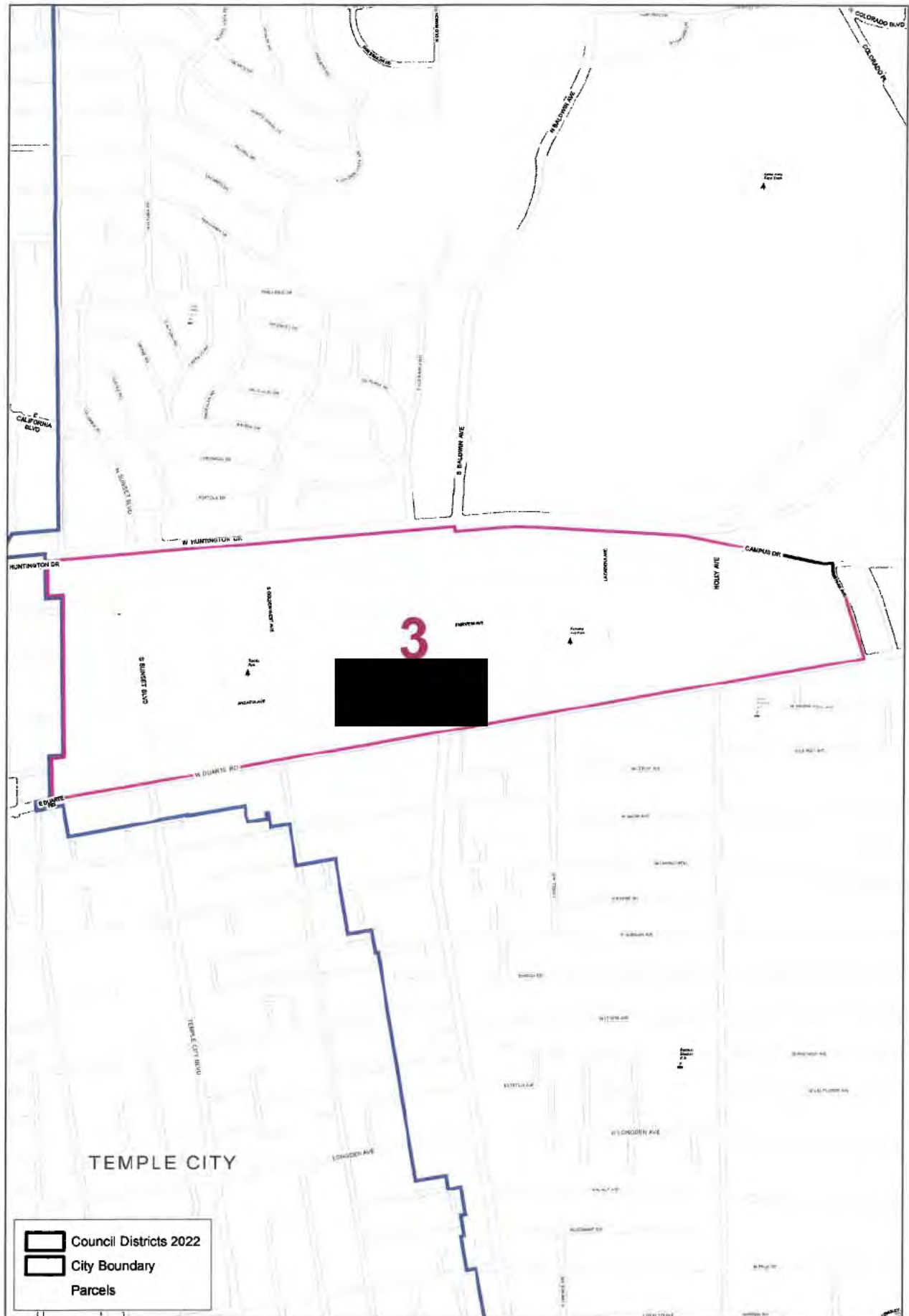

# Council District 3

City of Arcadia, California



MAY 28 2026

CITY OF ARCADIA  
CITY CLERK



# District 3 City Council Vacancy Appointment Application

\*\*\*\*PLEASE READ CAREFULLY AND COMPLETE THE APPLICATION IN FULL\*\*\*\*

The City of Arcadia is seeking applicants to fill the unexpired term for Arcadia City Council District 3. Complete applications must be submitted to [CityClerk@ArcadicaCA.gov](mailto:CityClerk@ArcadicaCA.gov) by **Friday, May 29, 2026, at 11:59 p.m.** Applicants considered for appointment must be available for interview by the City Council at a Special Meeting on **Tuesday, June 2, 2026, at 5:00 p.m.** in the City Council Chambers located at 240 W. Huntington Drive, Arcadia, CA 91007.

All submissions will receive a confirmation email. For questions regarding this application or the appointment process, please contact the City Clerk's Office at (626) 574-5455.

\*\*\*\*\*

NAME Ng Monje Cynthia DATE OF BIRTH [REDACTED]

LAST FIRST

RESIDENTIAL ADDRESS [REDACTED] Arcadia, CA 91007

(Note: Cannot be a mailing address or PO Box)

I CERTIFY THAT I AM A RESIDENT OF DISTRICT THREE (3)  YES  NO

PHONE NUMBER [REDACTED] EMAIL ADDRESS [REDACTED]

EMPLOYER JPL retiree OCCUPATION Senior Executive Administrator

HOW LONG HAVE YOU BEEN A RESIDENT? 20 + years ARE YOU AN ARCADIA REGISTERED VOTER?  YES  NO

\*\*\*\*\*

PLEASE ANSWER THE QUESTIONS BELOW. YOU MAY USE ADDITIONAL SHEETS OF PAPER AS NECESSARY.

### WHY ARE YOU INTERESTED IN SERVING ON THE ARCADIA CITY COUNCIL?

My late husband and I moved to Arcadia to raise our family. As soon as my sons were of the age to participate in Arcadia sports my late husband enthusiastically volunteered as a coach for Arcadia American Little League and AYSO. Throughout his coaching years (he coached til his very end) we connected with so many wonderful families and I would like to show them my gratitude for all their support during a very difficult time.

My late husband passed away in 2006 from cancer. My family as I knew it changed forever. This is a fact that my family changed in a devastating way but on the other hand, the Arcadia community showed me the true meaning of neighbors and community.

Arcadia families, teachers, coaches, school nurses and so many more did not allow us to grieve alone.

I truly believe in being part of the solution. Complaining and sitting on the sidelines would be wasted energy.

With the above being said, I am interested in serving Arcadia City council, to represent my community and be a voice for neighbors who feel unheard or underrepresented.

With the current unfortunate findings regarding the recent Ex Mayor, I feel it is important that the community has assurances that the next District 3 city council representative will be accountable, transparent, fiscally responsible and responsive. My goal would be to regain our community's trust and improve relationships by bridging the gap with residents, businesses and city staff to solve problems collaboratively.

**WHAT MOST QUALIFIES YOU FOR CITY COUNCIL SERVICE?**

I have over a decade of experience as a Senior Executive Administrator at NASA's Jet Propulsion Laboratory. In this roll, I managed complex administrative operations in an environment that demands the highest levels of integrity, discretion and accountability. We operate under strict zero tolerance policy for any security or ethical breaches and I have upheld these standards through-out my career, both on and off site.

I am a dedicated public servant who loves my country and our city of Arcadia. The skills I've developed at JPL have prepared me to serve effectively on City Council. I am confident I can bring thoughtful leadership and create meaningful, lasting improvements for our residents.

**CITY COUNCIL MEETINGS ARE ON THE FIRST AND THIRD TUESDAY OF EACH MONTH. I AM AWARE OF THE TIME COMMITMENT AND CAN FULFILL THE OBLIGATIONS OF AN APPOINTMENT TO THE CITY COUNCIL.**

YES  NO

**STATE LAW AND THE CITY CONFLICT OF INTEREST CODE REQUIRES CITY COUNCIL MEMBERS TO FILE A STATEMENT OF ECONOMIC INTERESTS (FORM 700) ANNUALLY AS WELL AS RELATED FORMS WHEN ASSUMING AND LEAVING OFFICE (e.g. sources of income, loans, gifts, investments, interest in real property as required by state law).**

**DO YOU AGREE TO FILE ALL REQUIRED FORMS IN A TIMELY MANNER AS REQUIRED BY THE CITY'S FILING OFFICIAL?**

YES  NO

**Email Your Completed Application To:**

[CityClerk@ArcadiaCA.gov](mailto:CityClerk@ArcadiaCA.gov)

**Questions? Please contact us at (626) 574-5455**

**REMINDER: THE DEADLINE TO SUBMIT YOUR APPLICATION IS FRIDAY, MAY 29, 2026, BY 11:59 P.M.**

**I HEREBY CERTIFY THAT THE FOREGOING INFORMATION IS TRUE AND CORRECT TO THE BEST OF MY KNOWLEDGE.**

[Redacted Signature]

SIGNATURE

May 28, 2026

DATE

**NOTE: The City of Arcadia reserves the right to use the information provided on this application to verify your residential address and voter registration status. The information provided on this application is for internal use only and confidential information will not be released to the public.**

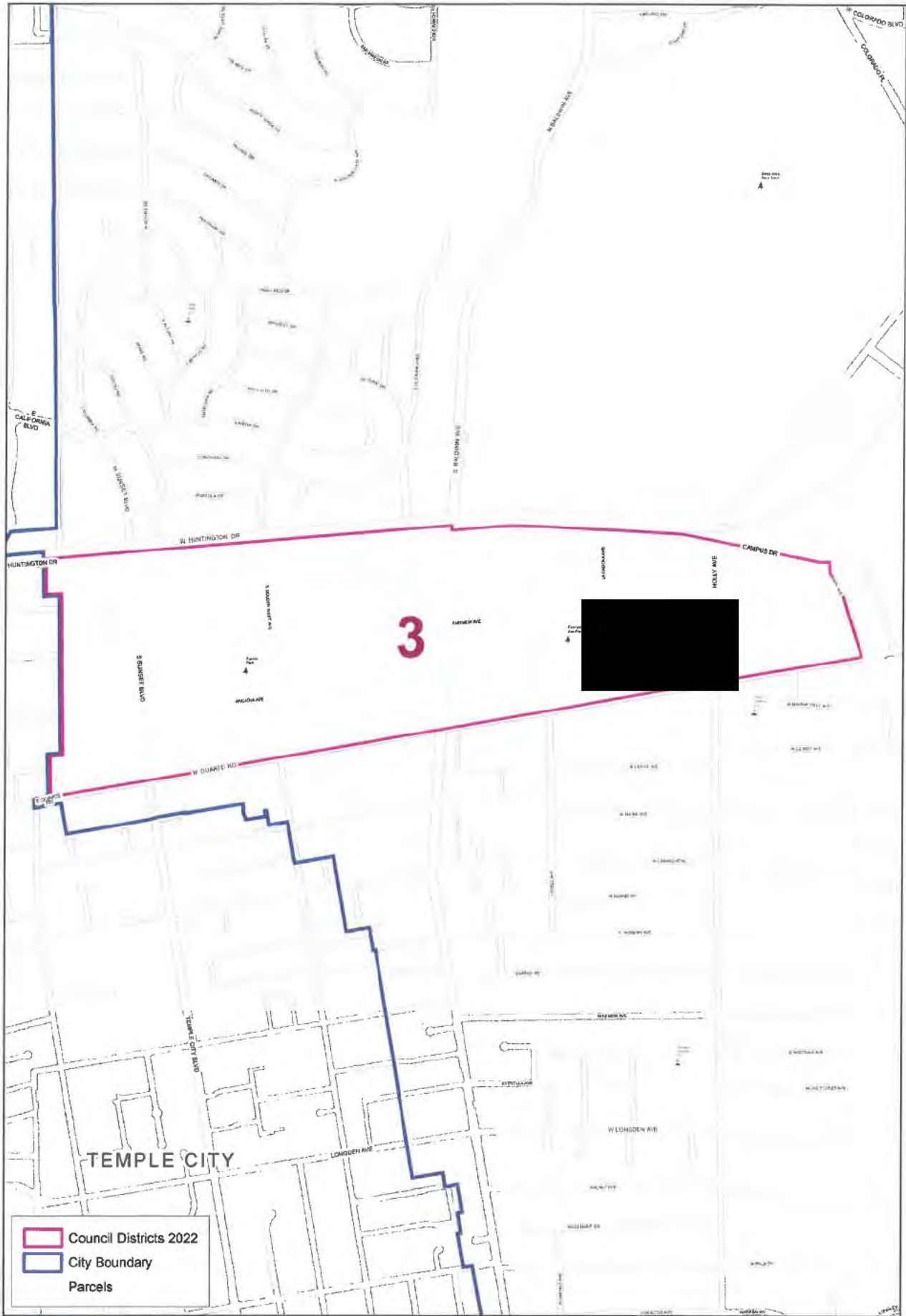

# Council District 3

City of Arcadia, California



MAY 22 2026

CITY OF ARCADIA  
CITY CLERK



# District 3 City Council Vacancy Appointment Application

\*\*\*\*PLEASE READ CAREFULLY AND COMPLETE THE APPLICATION IN FULL\*\*\*\*

The City of Arcadia is seeking applicants to fill the unexpired term for Arcadia City Council District 3. Complete applications must be submitted to [CityClerk@ArcadicaCA.gov](mailto:CityClerk@ArcadicaCA.gov) by **Friday, May 29, 2026, at 11:59 p.m.** Applicants considered for appointment must be available for interview by the City Council at a Special Meeting on **Tuesday, June 2, 2026, at 5:00 p.m.** in the City Council Chambers located at 240 W. Huntington Drive, Arcadia, CA 91007.

All submissions will receive a confirmation email. For questions regarding this application or the appointment process, please contact the City Clerk's Office at (626) 574-5455.

\*\*\*\*\*

NAME Szymkowski Beth DATE OF BIRTH [REDACTED]  
LAST FIRST

RESIDENTIAL ADDRESS [REDACTED] Arcadia, CA 91007  
(Note: Cannot be a mailing address or PO Box)

I CERTIFY THAT I AM A RESIDENT OF DISTRICT THREE (3)  YES  NO

PHONE NUMBER [REDACTED] EMAIL ADDRESS [REDACTED]

EMPLOYER Alhambra USD/Self OCCUPATION Educator, Screenwriter, Rental Property Owner

HOW LONG HAVE YOU BEEN A RESIDENT? 3 years ARE YOU AN ARCADIA REGISTERED VOTER?  YES  NO

\*\*\*\*\*

### PLEASE ANSWER THE QUESTIONS BELOW. YOU MAY USE ADDITIONAL SHEETS OF PAPER AS NECESSARY.

#### WHY ARE YOU INTERESTED IN SERVING ON THE ARCADIA CITY COUNCIL?

I would like to serve on the Arcadia City Council because I care deeply about this community and believe my background would allow me to bring a practical, balanced perspective to the role.

I moved to Arcadia from Studio City because I wanted to give my son access to the opportunities that come with living in a community like this. He is now in college, but moving here was one of the best decisions I ever made. Over the years, I have become increasingly appreciative of how well Arcadia is run. It is a safe, beautiful city with great parks, thriving local businesses, and a strong sense of community.

My professional experiences have given me the opportunity to work with many different kinds of people and viewpoints. As a college professor and substitute teacher, I have learned the importance of listening, patience, and clear communication. As a screenwriter, I have built a career around understanding people, finding common ground, and solving problems creatively. As the owner of rental properties in Los Angeles, I have seen firsthand how important housing policy can be and how important it is to protect the interests of both renters and property owners.

I also think I bring a perspective that reflects many of the people who live in Arcadia. I live in a neighborhood with a mix of homeowners, condo owners and renters, and I understand that different residents often have different priorities and concerns. I would approach decisions with an open mind and a focus on what is best for the community as a whole.

One of the things I admire most about Arcadia is that it is already doing so many things right. My goal would not be to reinvent the city, but to help preserve what makes it special while looking for opportunities to make it even better. I would love to see continued investment in local businesses and thoughtful development in areas such as First Street, which I believe has tremendous potential.

Most of all, I see this as an opportunity to give back to a community that has been very good to me and my family. I would be honored to serve and to help ensure that Arcadia remains a place where people want to live, work, and raise their families.



**WHAT MOST QUALIFIES YOU FOR CITY COUNCIL SERVICE?**

I bring a combination of lived experience in Arcadia, professional experience in education and communication, and firsthand knowledge of housing and property management. I understand both the resident and property owner perspective, and I approach issues with a practical, solutions-oriented mindset.

**CITY COUNCIL MEETINGS ARE ON THE FIRST AND THIRD TUESDAY OF EACH MONTH. I AM AWARE OF THE TIME COMMITMENT AND CAN FULFILL THE OBLIGATIONS OF AN APPOINTMENT TO THE CITY COUNCIL.**

YES  NO

**STATE LAW AND THE CITY CONFLICT OF INTEREST CODE REQUIRES CITY COUNCIL MEMBERS TO FILE A STATEMENT OF ECONOMIC INTERESTS (FORM 700) ANNUALLY AS WELL AS RELATED FORMS WHEN ASSUMING AND LEAVING OFFICE (e.g. sources of income, loans, gifts, investments, interest in real property as required by state law).**

**DO YOU AGREE TO FILE ALL REQUIRED FORMS IN A TIMELY MANNER AS REQUIRED BY THE CITY'S FILING OFFICIAL?**

YES  NO

**Email Your Completed Application To:**

[CityClerk@ArcadiaCA.gov](mailto:CityClerk@ArcadiaCA.gov)

**Questions? Please contact us at (626) 574-5455**

**REMINDER: THE DEADLINE TO SUBMIT YOUR APPLICATION IS FRIDAY, MAY 29, 2026, BY 11:59 P.M.**

**I HEREBY CERTIFY THAT THE FOREGOING INFORMATION IS TRUE AND CORRECT TO THE BEST OF MY KNOWLEDGE.**



SIGNATURE

May 22, 2026

DATE

**NOTE: The City of Arcadia reserves the right to use the information provided on this application to verify your residential address and voter registration status. The information provided on this application is for internal use only and confidential information will not be released to the public.**

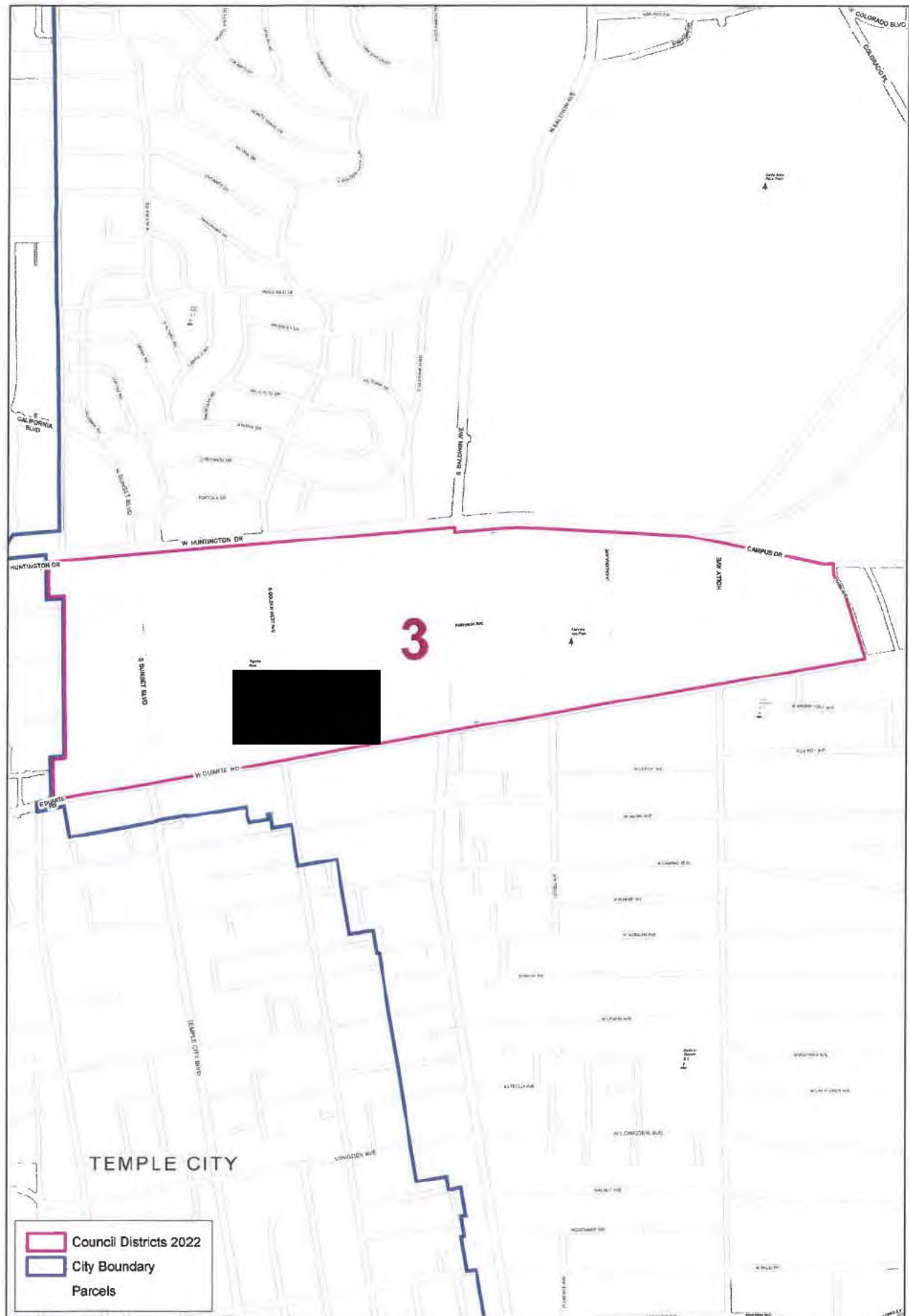

# Council District 3

City of Arcadia, California

RECEIVED

MAY 27 2026

CITY OF ARCADIA  
CITY CLERK



### District 3 City Council Vacancy Appointment Application

\*\*\*\*PLEASE READ CAREFULLY AND COMPLETE THE APPLICATION IN FULL\*\*\*\*

The City of Arcadia is seeking applicants to fill the unexpired term for Arcadia City Council District 3. Complete applications must be submitted to [CityClerk@ArcadicaCA.gov](mailto:CityClerk@ArcadicaCA.gov) by Friday, May 29, 2026, at 11:59 p.m. Applicants considered for appointment must be available for interview by the City Council at a Special Meeting on Tuesday, June 2, 2026, at 5:00 p.m. in the City Council Chambers located at 240 W. Huntington Drive, Arcadia, CA 91007.

All submissions will receive a confirmation email. For questions regarding this application or the appointment process, please contact the City Clerk's Office at (626) 574-5455.

\*\*\*\*\*

NAME Van Fleet Paul DATE OF BIRTH [REDACTED]  
LAST FIRST

RESIDENTIAL ADDRESS [REDACTED] Arcadia Ca 91007  
(Note: Cannot be a mailing address or PO Box)

I CERTIFY THAT I AM A RESIDENT OF DISTRICT THREE (3)  YES  NO

PHONE NUMBER [REDACTED] EMAIL ADDRESS [REDACTED]

EMPLOYER State Fund OCCUPATION Senior Claims Adjuster

HOW LONG HAVE YOU BEEN A RESIDENT? 27+ years ARE YOU AN ARCADIA REGISTERED VOTER?  YES  NO

\*\*\*\*\*

PLEASE ANSWER THE QUESTIONS BELOW. YOU MAY USE ADDITIONAL SHEETS OF PAPER AS NECESSARY.

#### WHY ARE YOU INTERESTED IN SERVING ON THE ARCADIA CITY COUNCIL?

I want to be a representative city council person for district 3.  
I am a long term resident living living at my current address for 28 years this July.  
I believe due to my long term residence in this area I can provide meaningful insight on the issues and needs of my community.  
I have previously run on 2 occasions for the position of City of Arcadia councilman as I wished to serve my community.

**WHAT MOST QUALIFIES YOU FOR CITY COUNCIL SERVICE?**

My almost 28 years of residency in Arcadia, all of which was in the current district 3.

I have been a State of California employee with State Fund as a claim adjuster for almost 24 years.

My position at State Fund is helping injured workers get the medical treatment they need to return to employment and get back to their preinjury lives.

My position requires me to deal with employers, providers, attorneys and the general public on a daily basis and ensure all legal requirements are followed to the letter.

I have no investments or personal ties with any business owner in the City of Arcadia so I would be able to act as an unbiased broker in any decision that I would be required to vote on.

In my 2 runs for the position of councilman for the city of Arcadia I did not accept one cent from any donor or assistance from any party. I did that so I would be able to represent everyone equally with no special interest owed to anyone other than the citizens of Arcadia.

**CITY COUNCIL MEETINGS ARE ON THE FIRST AND THIRD TUESDAY OF EACH MONTH. I AM AWARE OF THE TIME COMMITMENT AND CAN FULFILL THE OBLIGATIONS OF AN APPOINTMENT TO THE CITY COUNCIL.**

YES  NO

**STATE LAW AND THE CITY CONFLICT OF INTEREST CODE REQUIRES CITY COUNCIL MEMBERS TO FILE A STATEMENT OF ECONOMIC INTERESTS (FORM 700) ANNUALLY AS WELL AS RELATED FORMS WHEN ASSUMING AND LEAVING OFFICE (e.g. sources of income, loans, gifts, investments, interest in real property as required by state law).**

**DO YOU AGREE TO FILE ALL REQUIRED FORMS IN A TIMELY MANNER AS REQUIRED BY THE CITY'S FILING OFFICIAL?**

YES  NO

**Email Your Completed Application To:**

[CityClerk@ArcadiaCA.gov](mailto:CityClerk@ArcadiaCA.gov)

**Questions? Please contact us at (626) 574-5455**

**REMINDER: THE DEADLINE TO SUBMIT YOUR APPLICATION IS FRIDAY, MAY 29, 2026, BY 11:59 P.M.**

**I HEREBY CERTIFY THAT THE FOREGOING INFORMATION IS TRUE AND CORRECT TO THE BEST OF MY KNOWLEDGE.**

[Redacted Signature]

SIGNATURE

**May 27, 2026**

DATE

**NOTE: The City of Arcadia reserves the right to use the information provided on this application to verify your residential address and voter registration status. The information provided on this application is for internal use only and confidential information will not be released to the public.**

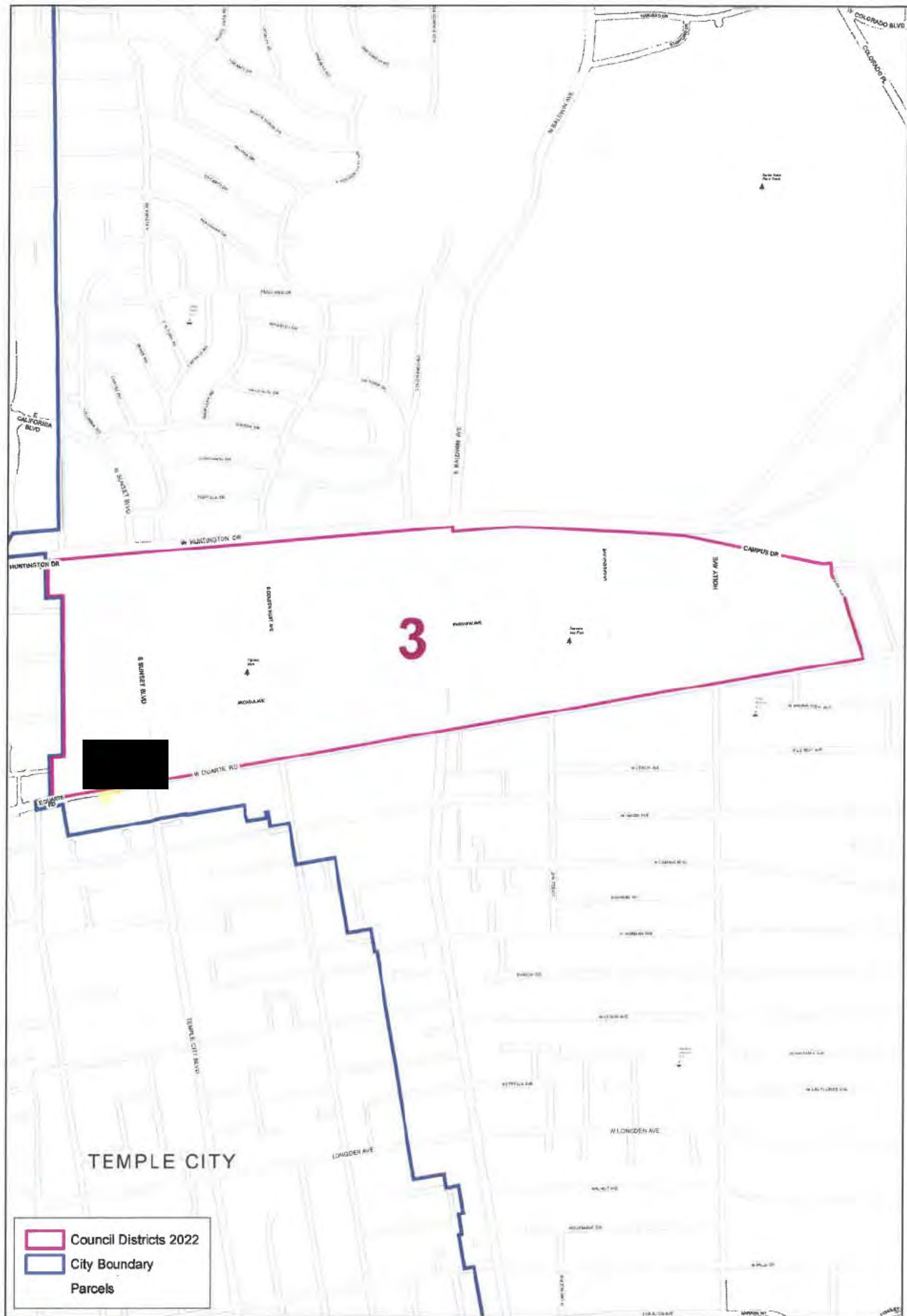

# Council District 3

City of Arcadia, California



MAY 21 2026

CITY OF ARCADIA  
CITY CLERK



City of  
ARCADIA

### District 3 City Council Vacancy Appointment Application

\*\*\*\*PLEASE READ CAREFULLY AND COMPLETE THE APPLICATION IN FULL\*\*\*\*

The City of Arcadia is seeking applicants to fill the unexpired term for Arcadia City Council District 3. Complete applications must be submitted to [CityClerk@ArcadicaCA.gov](mailto:CityClerk@ArcadicaCA.gov) by Friday, May 29, 2026, at 11:59 p.m. Applicants considered for appointment must be available for interview by the City Council at a Special Meeting on Tuesday, June 2, 2026, at 5:00 p.m. in the City Council Chambers located at 240 W. Huntington Drive, Arcadia, CA 91007.

All submissions will receive a confirmation email. For questions regarding this application or the appointment process, please contact the City Clerk's Office at (626) 574-5455.

\*\*\*\*\*  
NAME WALTON LISA DATE OF BIRTH [REDACTED]  
LAST FIRST

RESIDENTIAL ADDRESS [REDACTED] ARCADIA, CA 91007  
(Note: Cannot be a mailing address or PO Box)

I CERTIFY THAT I AM A RESIDENT OF DISTRICT THREE (3)  YES  NO

PHONE NUMBER [REDACTED] EMAIL ADDRESS [REDACTED]

EMPLOYER BANK OF AMERICA OCCUPATION VP; SVCS

HOW LONG HAVE YOU BEEN A RESIDENT? 47 ARE YOU AN ARCADIA REGISTERED VOTER?  YES  NO

PLEASE ANSWER THE QUESTIONS BELOW. YOU MAY USE ADDITIONAL SHEETS OF PAPER AS NECESSARY.

WHY ARE YOU INTERESTED IN SERVING ON THE ARCADIA CITY COUNCIL?

BORN AND RAISED IN ARCADIA, I HAVE PROUDLY CALLED THIS COMMUNITY HOME FOR 47 YEARS. ARCADIA IS WHERE I WAS RAISED, WHERE I BUILT LIFELONG RELATIONSHIPS, AND WHERE I CHOSE TO RAISE MY FAMILY. I'M RUNNING FOR CITY COUNCIL BECAUSE I CARE DEEPLY ABOUT PRESERVING THE CHARACTER, SAFETY, AND SENCE OF COMMUNITY THAT MAKE ARCADIA SPECIAL. I WANT TO SERVE WITH INTEGRITY, LISTEN TO RESIDENTS, AND HELP ENSURE OUR CITY CONTINUES TO THRIVE FOR FUTURE GENERATIONS WHILE HONORING THE VALUES THAT HAVE SHAPED IT FOR DECADES.

**WHAT MOST QUALIFIES YOU FOR CITY COUNCIL SERVICE?**

WHAT QUALIFIES ME TO SERVE ON CITY COUNCIL IS MY LIFE LONG COMMITMENT TO THE ARCADIA COMMUNITY. HAVING LIVED IN ARCADIA FOR 47 YEARS, I UNDERSTAND THE NEEDS, VALUES, AND CONCERNS OF RESIDENTS BECAUSE I'VE EXPERIENCED THEM FIRST HAND. I'VE BUILT STRONG RELATIONSHIPS THROUGHOUT THE COMMUNITY, RAISED MY FAMILY HERE, AND REMAINED DEEPLY INVESTED IN THE CITY'S FUTURE. IN ADDITION, MY SERVICE ON THE BEAUTIFUL COMMISSION HAS GIVEN ME VALUABLE EXPERIENCE WORKING COLLABORATIVELY TO HELP PRESERVE AND ENHANCE THE PRIDE AND CHARACTER OF OUR CITY. MY DEEP ROOTS, COMMUNITY INVOLVEMENT, AND PASSION FOR LISTENING TO RESIDENTS AND BRINGING PEOPLE TOGETHER GIVE ME THE PERSPECTIVE AND DEDICATION NEEDED TO SERVE ARCADIA THOUGHTFULLY AND EFFECTIVELY.

**CITY COUNCIL MEETINGS ARE ON THE FIRST AND THIRD TUESDAY OF EACH MONTH. I AM AWARE OF THE TIME COMMITMENT AND CAN FULFILL THE OBLIGATIONS OF AN APPOINTMENT TO THE CITY COUNCIL.**

YES  NO

**STATE LAW AND THE CITY CONFLICT OF INTEREST CODE REQUIRES CITY COUNCIL MEMBERS TO FILE A STATEMENT OF ECONOMIC INTERESTS (FORM 700) ANNUALLY AS WELL AS RELATED FORMS WHEN ASSUMING AND LEAVING OFFICE (e.g. sources of income, loans, gifts, investments, interest in real property as required by state law).**

**DO YOU AGREE TO FILE ALL REQUIRED FORMS IN A TIMELY MANNER AS REQUIRED BY THE CITY'S FILING OFFICIAL?**

YES  NO

**Email Your Completed Application To:**

**[CityClerk@ArcadiaCA.gov](mailto:CityClerk@ArcadiaCA.gov)**

**Questions? Please contact us at (626) 574-5455**

**REMINDER: THE DEADLINE TO SUBMIT YOUR APPLICATION IS FRIDAY, MAY 29, 2026, BY 11:59 P.M.**

**I HEREBY CERTIFY THAT THE FOREGOING INFORMATION IS TRUE AND CORRECT TO THE BEST OF MY KNOWLEDGE.**

[Redacted Signature]

**SIGNATURE**

5-21-26

**DATE**

**NOTE: The City of Arcadia reserves the right to use the information provided on this application to verify your residential address and voter registration status. The information provided on this application is for internal use only and confidential information will not be released to the public.**

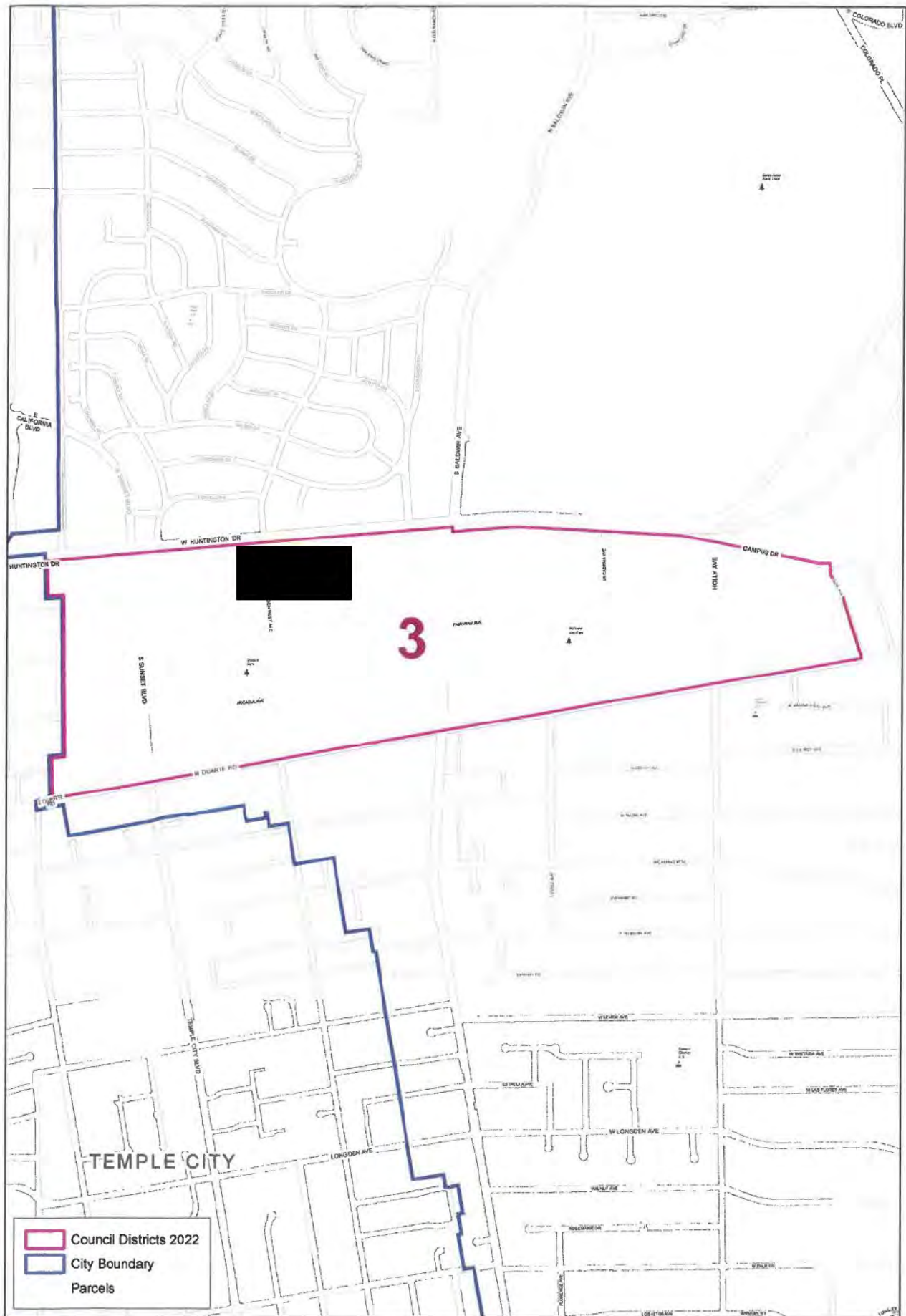

**Council District 3**  
 City of Arcadia, California



**DATE:** June 16, 2026

**TO:** Honorable Mayor and City Council

**FROM:** Dominic Lazzaretto, City Manager  
By: Linda Rodriguez, City Clerk

**SUBJECT:** APPOINTMENTS TO CITY BOARDS AND COMMISSIONS  
**CEQA: Not a Project**  
**Recommendation: Make Appointments**

### **SUMMARY**

Annually, the City Council appoints Arcadia residents to serve on various City Boards and Commissions. This year, six of the eight City Boards and Commissions have openings for appointments. This agenda item will enable the City Council to take action to fill vacancies on the Arcadia Museum Commission, Human Resources Commission, Library Board of Trustees, Planning Commission, Recreation and Parks Commission, and Senior Citizens Commission. It is recommended that the City Council make the necessary appointments to fill vacancies on Arcadia's Boards and Commissions, effective July 1, 2026.

### **BACKGROUND**

Arcadia's Boards and Commissions serve to advise the City Council on matters that impact the community. There are eight City Boards and Commissions in total: Arcadia Beautiful, Arcadia Health, Arcadia Museum, Human Resources, Library Board of Trustees, Planning, Recreation and Parks, and Senior Citizens. All Boards and Commissions have member terms beginning on July 1 and ending June 30, unless a vacancy occurs and an unexpired term is being filled.

Most City Boards and Commissions are advisory in nature except for the Human Resources Commission, the Library Board of Trustees, and the Planning Commission, who have been granted additional duties and powers. Each Board and Commission

is governed by the protocols in their handbook, as well as any specific provisions in their authorizing ordinances. Each spring, the City Clerk's Office initiates a recruitment process for City Boards and Commissions. The recruitment period begins a few months before appointments are made by the City Council in June.

The City advertises Board and Commission openings through its communication channels that include the City's website, social media channels, monthly utility bill insert, and monthly email newsletter. If there are any mid-term vacancies, the City Clerk's Office revisits the list of applicants not currently appointed, but have kept their resume on file with the City, and solicits their interest in filling the applicable vacancy. Any interested applicants are then recommended to the City Council for appointment at the next available meeting. Alternatively, at the City Council's discretion, a full recruitment process can be undertaken to fill an unplanned vacancy.

Each member of a City Board and Commission may generally serve up to two (2) consecutive, four-year terms, with two exceptions. The first exception pertains to filling an unexpired term, as residents may fill an unexpired term and then be appointed to two consecutive terms on the same board or commission. The second exception relates to term limits for the Senior Citizens Commission, which are two years in duration. Members of the Senior Citizens Commission may serve up to two (2) consecutive, two-year terms.

## **DISCUSSION**

Six City Boards and Commissions have openings this year, with a total of 16 openings overall. Available openings are being sought by 29 new applicants and four incumbents, for a total of 33 applicants. All five districts of Arcadia are represented in the 33-person applicant pool. It is recommended that the City Council fill vacancies on the following Boards and Commissions:

- Arcadia Museum Commission (4 positions open)
- Human Resources Commission (1 position open)
- Library Board of Trustees (2 positions open)
- Planning Commission (3 positions open)

- Recreation and Parks Commission (1 position open)
- Senior Citizens Commission (3 At-large, including one position to fill an unexpired term ending June 30, 2027, and 2 Service Club positions open)

In order to facilitate City Council action, the following documents are attached to this report:

1. Attachment No. 1 - Appointment Summary Sheet showing the number of vacancies open on each board/commission, which members are eligible for reappointment, and the names of individuals who have submitted resumes and are interested in serving on that board/commission.
2. Attachment No. 2 - Current Board and Commission Roster.
3. Attachment No. 3 – Board/Commission Applications and letters of recommendation from Arcadia Service Clubs.

All applicants have been verified as Arcadia residents, being at least 18 years of age, and registered voters of the City, in accordance with the Arcadia City Charter.

### **ENVIRONMENTAL ANALYSIS**

The proposed action does not constitute a project under the California Environmental Quality Act (“CEQA”), as it can be seen with certainty that it will have no impact on the environment.

### **FISCAL IMPACT**

There is no fiscal impact from City Council making appointments to City Boards and Commissions.

### **RECOMMENDATION**

It is recommended that the City Council determine that this action does not constitute a project under the California Environmental Quality Act (“CEQA”); and make appointments to fill vacancies on Arcadia Boards and Commissions, effective July 1, 2025.

- Attachment No. 1: Appointment Summary Sheet
- Attachment No. 2: Current Board and Commission Roster
- Attachment No. 3: Board/Commission Applications

**Attachment No. 1**

<b>2026 BOARDS AND COMMISSIONS APPOINTMENT SUMMARY</b>			
<b>ARCADIA MUSEUM COMMISSION</b>		<b>* 4 Positions Open</b>	<b>Interested in 2026</b>
<b>Applicants on File</b>	Marilyn Daleo - D5	Eligible for Reappointment	<b>YES</b>
	Dale Carter - D5 (Filling Unexpired Term)	Eligible for New Appointment	<b>YES</b>
	Ethel Laczko - D5		
<b>HUMAN RESOURCES COMMISSION</b>		<b>* 1 Position Open</b>	<b>Interested in 2026</b>
<b>Applicants on File</b>	Huong Sueyen McMahon	Eligible for Reappointment	<b>NO</b>
	William Hsu - D4		
	Johnny Tseng - D2		
	Kenneth Proulx - D1		
<b>LIBRARY BOARD</b>		<b>*2 Position Open</b>	<b>Interested in 2026</b>
<b>Applicants on File</b>	Connie Liao - D4	Eligible for Reappointment	<b>NO</b>
	Johnny Tseng - D2		
	Lois Merritt - D2		
	Elizabeth Renfrew - D5		
	Jeff Chang - D1		
	Sara Noji - D5		
	Roberta Marquez - D5		
	Bianca Picasso - D5		
	Carol Saunders - D1		
<b>PLANNING COMMISSION</b>		<b>* 3 Positions Open</b>	<b>Interested in 2026</b>
<b>Applicants on File</b>	Domenico Tallerico - D1	Eligible for Reappointment	<b>YES</b>
	Angela Hui - D5	Eligible for Reappointment	<b>YES</b>
	Johnny Tseng - D2		
	Chang Lee - D5 (Currently serving on HR Commission - term expires 06/30/28)		
	Ricky Lau - D1		
	Kevin Mchugh - D4		
	Michael Cham - D5 (Currently serving on the ABC Commission - term expires 06/30/29)		
	Colin Leung - D4		
	Cris Arzate - D5		
Kenneth Chan - D5			
<b>RECREATION AND PARKS COMMISSION</b>		<b>* 1 Position Open</b>	<b>Interested in 2026</b>
<b>Applicants on File</b>	Gregory Vanni	Eligible for Reappointment	<b>NO</b>
	Johnny Tseng - D2		
	Mary Jane Card - D2		
	Kenneth Proulx - D1		
	Robert Gibson - D1		
	Ricky Lau - D1		
	Connie Liao - D4		
	Yuting Cheng - D4		
	Jacqueline Huang - D4		
Cris Arzate - D5			
<b>SENIOR CITIZENS COMMISSION (2-year terms)</b>		<b>*3 At-Large Positions Open (including unexpired term ending 06/30/2027) *2 Club Positions Open</b>	<b>Interested in 2026</b>
<b>At-Large Appointments</b>	Ethel Laczko - D5	Eligible for Reappointment	<b>NO</b>
<b>Applicants on File</b>	Cris Arzate - D5	Eligible for Reappointment	<b>NO</b>
	Douglas Meyer - D4		
	Johnny Tseng - D2		
	Angela Lai - D3		
	Azar Dabiri - D4		
	Connie Liao - D4		
	Miriam Carter - D5 (Terming out of Library Board 06/30/26)		
	Derek Yeung - D5		
<b>Club Appointments</b>			<b>Interested in 2026</b>
<b>Assistance League</b>	Shirley Curley (Filling Unexpired Term)	Eligible for Reappointment	<b>NO</b>
	Donna Salter		<b>YES</b>
<b>Golden Senior Club</b>	Doris Arbour (Filling Unexpired Term)	Eligible for Reappointment	<b>YES</b>

## Attachment No. 2

### ARCADIA CITY COUNCIL & BOARDS AND COMMISSIONS ROSTER 240 W. HUNTINGTON DRIVE, ARCADIA, CA 91007

<u>CITY COUNCIL</u>	<u>TERM EXPIRES</u>
<b>Regular Meetings – 1<sup>st</sup> &amp; 3<sup>rd</sup> Tuesday of each month, Conference Room, 6:00 p.m.; Council Chamber, 7:00 p.m.</b>	
Paul P. Cheng, Mayor	November 2028#
David Fu, Mayor Pro Tem	November 2028
Dr. Michael Cao, Council Member	November 2026
Sharon Kwan, Council Member	November 2026
<b>Vacant</b>	November 2026
 <b><u>ARCADIA BEAUTIFUL COMMISSION</u></b>	
<b>Meetings are held as needed at a time and place tbd (Liaison: Kwan)</b>	
Ashish Guha	06/30/29
Karren Levine	06/30/29
Michael Cham	06/30/29
Gary Brewer	06/30/27#
Vivien Watts	06/30/27
Uyen Wong (Filling Unexpired Term)	06/30/28
Lisa Walton	06/30/28
 <b><u>ARCADIA HEALTH COMMISSION</u></b>	
<b>Meeting Schedule: Meets quarterly on the 1<sup>st</sup> Wednesday of the quarterly month, 375 Campus Drive, 5:00 p.m. (Liaison: Cao)</b>	
<b>At-Large Appointments</b>	
David Ratto	06/30/29
Dino Clarizio	06/30/29
Desiree Molina	06/30/29
<b>Local Health Care Appointments</b>	
Chia-Chieh Hu – Huntington Health	06/30/29
Mark Feng – Kaiser Permanente	06/30/29
Angela Thomassian – Keck Medicine of USC	06/30/29
Clifford Daniels – USC Arcadia Hospital	06/30/29
 <b><u>ARCADIA MUSEUM COMMISSION</u></b>	
<b>Meetings are held on 1<sup>st</sup> Wednesday of every other month, Museum Conference Room, 5:00 p.m. (Liaison: Kwan)</b>	
Dale Carter (Filling Unexpired Term)	06/30/26#
Virginia Blitz	06/30/26#
Marilyn Daleo	06/30/26
<b>Vacant</b>	06/30/26
Angela Ayala	06/30/28
 <b><u>HUMAN RESOURCES COMMISSION</u></b>	
<b>Regular Meetings – 2<sup>nd</sup> Thursday of each month, Council Chamber, 5:30 p.m. (Liaison: Cao)</b>	
Tina Lee Rodriguez	06/30/29#
Huong Sueyen McMahon	06/30/26
Kaitlyn Jeong	06/30/27#
Lula Eskander	06/30/28#
Chang Lee	06/30/28

Revised 06/02/26

# Indicates serving second term

**TERM EXPIRES**

**LIBRARY BOARD**

**Regular Meetings – 3<sup>rd</sup> Thursday of each month, Library Conference Room, 4:30 p.m. (Liaison: Fu)**

Barbara Delphey (Filling Unexpired Term)	06/30/29#
Miriam Carter	06/30/26#
Connie Liao	06/30/26
Barbara Ansell (Filling Unexpired Term)	06/30/27
Hsiuchen Chen	06/30/28

**PLANNING COMMISSION**

**Regular Meetings – 2<sup>nd</sup> & 4<sup>th</sup> Tuesday of each month, Council Chamber, 7:00 p.m. (Liaison: Fu)**

Marilynne Wilander	06/30/26#
Domenico Tallerico	06/30/26
Angela Hui	06/30/26
David Arvizu	06/30/27
Vincent Tsoi	06/30/28

**RECREATION AND PARKS COMMISSION**

**Regular Meetings – 2<sup>nd</sup> Wednesday of each month, Recreation Department, 375 Campus Drive, 6:00 p.m. (Liaison: Kwan)**

Gregory Vanni	06/30/26
Matthew Goldsby (Filling Unexpired Term)	06/30/27#
Sonny Mediana	06/30/27
Roberto Ayala	06/30/28
Valerie Cheung	06/30/28#

**SENIOR CITIZENS COMMISSION**

**Regular Meetings – 1<sup>st</sup> Thursday of each month, Recreation Department, 375 Campus Drive, 4:00 p.m. (Liaison: Kwan)**

**At-Large Appointments**

<b>Vacant</b>	06/30/27
Ethel Laczko	06/30/26
Cris Arzate	06/30/26

**Club Appointments**

Steve Sherman – Senior Men's Club	06/30/27#
Marilyn Mazone – Traveler's Club	06/30/27
Shirley Curley – Assistance League (Filling Unexpired Term)	06/30/26
Doris Arbour – Golden Senior Club (Filling Unexpired Term)	06/30/26

**ARCADIA MUSEUM  
COMMISSION  
APPLICANTS**



# City of Arcadia Board/Commission Application

RECEIVED

MAY 5 2026

CITY OF ARCADIA  
CITY CLERK

PLEASE PLACE A CHECK MARK NEXT TO THE BOARD OR COMMISSION FOR WHICH YOU WOULD LIKE TO APPLY (more than one selection may be made):

- |   |  |
|---|--|
| <input type="checkbox"/> Arcadia Beautiful Commission*        | <input type="checkbox"/> Planning Commission             |
| <input checked="" type="checkbox"/> Arcadia Museum Commission | <input type="checkbox"/> Recreation and Parks Commission |
| <input type="checkbox"/> Human Resources Commission           | <input type="checkbox"/> Senior Citizens Commission      |
| <input type="checkbox"/> Library Board of Trustees            | <input type="checkbox"/> Arcadia Health Commission       |

NAME Marilyn Daleo DATE OF BIRTH (mm/dd/yyyy) [REDACTED]  
FIRST LAST

RESIDENTIAL ADDRESS [REDACTED] Arcadia, CA 91006  
(Note: Cannot be a mailing address or PO Box)

BUSINESS ADDRESS (HEALTH COMMISSION ONLY) n/a

I CERTIFY THAT I AM A RESIDENT OF DISTRICT  ONE  TWO  THREE  FOUR  FIVE  
 N/A (Health Commission Only)

PHONE NUMBER [REDACTED] EMAIL ADDRESS [REDACTED]

OCCUPATION Retired Public Information Officer EMPLOYER Retired from Arcadia Unified School District

ARE YOU AN ARCADIA REGISTERED VOTER?  YES  NO

HOW LONG HAVE YOU BEEN A RESIDENT? (If Applicable) 59 years

PLEASE ANSWER THE QUESTIONS BELOW. YOU MAY USE ADDITIONAL SHEETS OF PAPER AS NECESSARY.

EDUCATION (Include professional or vocational licenses or certificates)

Please see additional page.

COMMUNITY INVOLVEMENT (List organization memberships and committee assignments)

Please see additional page.

PLEASE DESCRIBE ANY BACKGROUND, TRAINING, OR INTERESTS THAT QUALIFY YOU AS AN APPOINTEE

Please see additional page.

WHAT INTERESTS YOU ABOUT THE BOARD/COMMISSION YOU ARE APPLYING FOR?

Please see additional page.

ARE YOU AWARE OF THE TIME COMMITMENT NECESSARY TO FULFILL THE OBLIGATIONS OF AN APPOINTMENT TO THIS POSITION?

YES  NO

NOTE: FOR LIBRARY BOARD OF TRUSTEE AND PLANNING COMMISSION APPLICATIONS ONLY  
STATE LAW AND THE CITY CONFLICT OF INTEREST CODE REQUIRES THAT LIBRARY BOARD OF TRUSTEE MEMBERS AND PLANNING COMMISSIONERS FILE A STATEMENT OF ECONOMIC INTERESTS (FORM 700) ANNUALLY AS WELL AS RELATED FORMS WHEN ASSUMING AND LEAVING OFFICE (e.g. sources of income, loans, gifts, investments, interest in real property as required by state law). DO YOU AGREE TO FILE ALL REQUIRED FORMS IN A TIMELY MANNER AS REQUIRED BY THE CITY'S FILING OFFICIAL?

YES  NO

---

**\*ARCADIA BEAUTIFUL APPLICANTS ONLY**

ARE YOU AWARE THAT THE PRIMARY FUNCTION OF THE ARCADIA BEAUTIFUL COMMISSION IS TO ACT AS JUDGES FOR THE COMMISSIONS AWARD PROGRAMS (Spring Home, Holiday Decoration, and Water Smart Hero awards)?

YES  NO

DO YOU HAVE THE ABILITY TO TRAVEL BY CAR DURING THE DAY AND IN THE EVENING FOR THE PURPOSE OF JUDGING?

YES  NO

THE ARCADIA BEAUTIFUL COMMISSION USUALLY HAS FOUR REGULAR MEETINGS EACH YEAR WITH ADDITIONAL MEETINGS AND/OR TIME COMMITMENTS SCHEDULED FOR THE PURPOSE OF CONDUCTING JUDGING FOR THE AWARD PROGRAMS, PARTICIPATING IN A 3-4 HOUR HOLIDAY DECORATION AWARD RECOGNITION EVENT, AND PARTICIPATING IN ARBOR DAY PROGRAMS. ADDITIONALLY, PRELIMINARY JUDGING FOR THE SPRING HOME AND HOLIDAY DECORATION AWARDS IS DONE WITH EACH COMMISSIONER TAKING RESPONSIBILITY FOR A SECTION OF THE CITY AND DRIVING THROUGH THE NEIGHBORHOODS TO SELECT THEIR NOMINATIONS FOR FINAL JUDGING BY THE COMMISSION. ARE YOU ABLE TO FULFILL THIS TIME COMMITMENT?

YES  NO

---

I HEREBY CERTIFY THAT THE FOREGOING INFORMATION IS TRUE AND CORRECT TO THE BEST OF MY KNOWLEDGE.



5-4-26

DATE

NOTE: The City of Arcadia reserves the right to use the information provided on this application to verify your residential address and voter registration status. The information provided on this application is for internal use only and confidential information will not be released to the public.

PLEASE SUBMIT YOUR COMPLETED APPLICATION TO: CITY CLERK'S OFFICE  
240 W. HUNTINGTON DRIVE  
ARCADIA, CA 91007

OR

Email us at [CityClerk@ArcadiaCA.gov](mailto:CityClerk@ArcadiaCA.gov)

Questions? Please contact us at (626) 574-5455

**EDUCATION (Include professional or vocational licenses or certificates)**

Montebello High School/Class of 1963; East Los Angeles College/Business and Marketing, 1965; Pasadena City College/Journalism and Media Relations Extension Courses, 1990s

**COMMUNITY INVOLVEMENT (List organization memberships and committee assignments)**

I have been active in the City of Arcadia since the early 1970s. I am currently First Vice President of the Arcadia Woman's Club. I was a founding member of the Friends of the Arcadia Museum (FAM) and have served as Treasurer since inception in 2013. FAM provides financial and hands-on support for the Museum's programs and educational outreach and I have been a part of that mission for nearly 10 years.

I hold membership in the Arcadia Historical Society, the Friends of the Arcadia Library, Arcadia Coordinating Council, and the Chamber of Commerce (residential member). I am a member of Arcadia Elks Lodge 2025 and a sustaining member of the Assistance League of Arcadia.

**PLEASE DESCRIBE ANY BACKGROUND, TRAINING, OR INTERESTS THAT QUALIFY YOU AS AN APPOINTEE:**

For over 50 years I have been involved in many facets of Arcadia's history and in recent times have been involved in activities that help preserve it. Having served on the City's Museum Commission the last four years has been a continuance of my interest and support for honoring Arcadia's history. When it comes to Arcadia's history, I have often been a participant, and always an observer, but in both instances, I am passionate and proud to be a part of it. The narrative below, which describes some of my community involvement, serves to point out how I have been a part of Arcadia's history since the 1970s.

My early involvement in Arcadia affairs started with being a member of the Arcadia Junior Woman's Club from 1971 until it disbanded in the early 2000s. Juniors worked closely with the Arcadia Recreation Department on such projects as the Penny Carnival and Baby Show. From Juniors my involvement expanded to such groups as the Arcadia Tournament of Roses Association where I held the positions of Press Chairman and Advisor to the Miss Arcadia Court. As chaperone to the Arcadia Rose Court, highlights included taking the girls to Hinshaw's and Buffums for outfits and gowns, the Coronation Ball at Santa Anita Race Track where the Queen was announced, and getting the Court to Arcadia's float lined up on Orange Grove Avenue by 3 a.m. on January 1<sup>st</sup>. I was involved with the Infield Picnic, Workout Breakfast and float viewing parties that are now just a memory. I was also a member of the Methodist Hospital Auxilliary and on the Friends of the Arcadia Public Library Board for several years, to name a few.

I served on the City's Library Board of Trustees for ten years. I was first appointed in September 1982 with subsequent reappointments in June 1984 and June 1988, serving until June of 1992. I was selected for the City's Bicentennial Commission and the Diamond Jubilee Committee. I served on the COPS Committee which worked to pass the ballot measure to build Arcadia's state-of-the-art Police Station.

In the area of education and Arcadia schools, I was PTA president of Camino Grove Elementary School and held various Board positions at the middle school, high school and PTA Council level. I was a founding member of the Arcadia Education Foundation in 1981. My children were both active in the AUSD music program beginning in 4<sup>th</sup> grade and continuing through high school and I was active in the Dana Music Club and the Arcadia High School Music Club, holding office, coordinating band trips, serving as Music Camp counselor, Spaghetti Dinner committee, fundraising and the like. I worked on several AUSD Bond Issues and in 1981 chaired with Dr. Dennis Lojeski, AUSD's Measures A and B which were focused at not having to close two of Arcadia's eight elementary schools at the time.

Adding to this, in 1984 I was hired by the Arcadia Unified School District to serve as Public Information and Communications Consultant, a position I held for over 29 years. In this capacity I handled the District's

internal and external communications, media relations, photography, website content, staff recognition, event planning and un-official historian. In 29 years I communicated, documented and archived Arcadia Unified School District's history as well as attending almost every School Board meeting. In 2006 the District was successful in passing Measure I, a \$218 million bond issue which brought about the renovation of every school site and the long awaited construction of the Arcadia Performing Arts Center which I had the privilege of documenting and help chair its public debut. I retired from Arcadia School District in 2013.

As a member of the Arcadia Woman's Club I have been instrumental in preserving the 108 year old history of the Club. In 2014, along with Floretta Lauber, I organized all of our historical scrapbooks and records and donated them to the Gilb Museum of Arcadia Heritage for safekeeping and preservation. In July of 2021 we celebrated the anniversary of the groundbreaking and dedication of the Arcadia Woman's Club 90-year old Clubhouse. In conjunction with that milestone, I headed up efforts to have this gem of Arcadia history designated as Arcadia's first City Landmark. To achieve this, I raised funds to cover the cost of the professional consulting service to validate the historical criteria and prepare the official application. The Clubhouse was named Arcadia's Historic Landmark No. 1 by Arcadia City Council on March 1, 2022.

My husband, Michael Daleo, was involved in the community as well as being a 36-year member of the Arcadia Police Department. After completing the Police Academy, he started as an Arcadia Police Reserve Officer in 1976. In 1994 the Department hired him full time to become the Department's first Crime Analyst and establish the APD Crime Analysis Unit which he did, and which was highly successful until his passing in 2010. Being married to someone who was with Arcadia Police Department for 36 years provided a lot of awareness of law enforcement history. In the early years, Mike was also in Arcadia Jaycees and a member of the Arcadia Lions Club, experiences and memories of which I recall.

#### **WHAT INTERESTS YOU ABOUT THE BOARD/COMMISSION YOU ARE APPLYING FOR?**

The Gilb Museum of Arcadia Heritage has made great strides in recent years. The Curator, Education Coordinator and Museum City Intern are ambitious, innovative, and forward thinking, enriching the offerings of the Museum and generating a greater awareness of this wonderful community resource. I would love to be re-appointed to the Museum Commission where I could further support the success and growth of this excellent facility. I have enjoyed serving my first term and feel that as a re-appointed member of the Museum Commission I can continue to provide insights and be helpful to this entity that is preserving and promoting Arcadia's history.

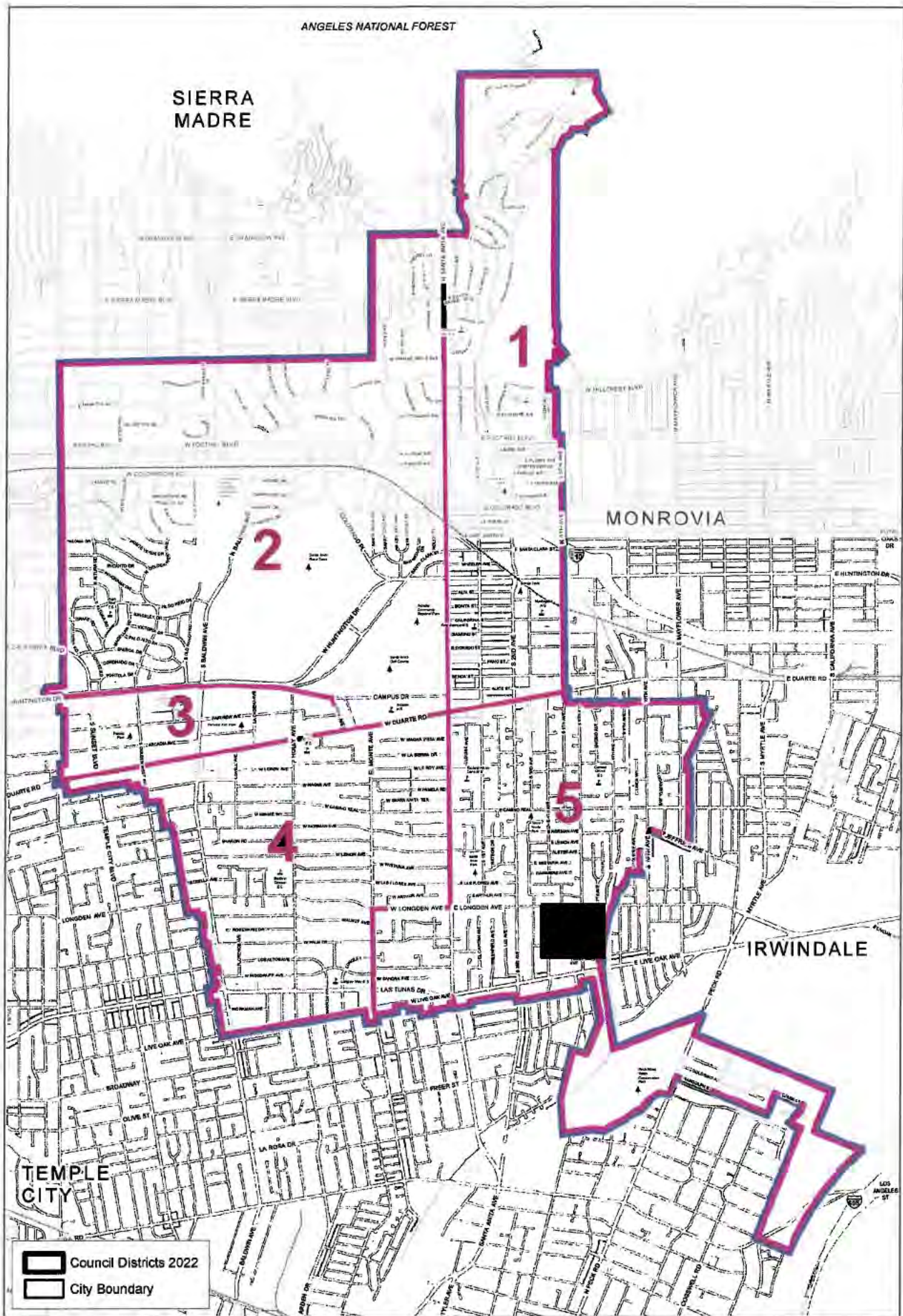

**Council District**  
*City of Arcadia, California*



# City of Arcadia Board/Commission Application

RECEIVED

MAY 14 2026

PLEASE PLACE A CHECK MARK NEXT TO THE BOARD OR COMMISSION FOR WHICH YOU WOULD LIKE TO APPLY (more than one selection may be made):

CITY OF ARCADIA  
CITY CLERK

- |   |  |
|---|--|
| <input type="checkbox"/> Arcadia Beautiful Commission*        | <input type="checkbox"/> Planning Commission             |
| <input checked="" type="checkbox"/> Arcadia Museum Commission | <input type="checkbox"/> Recreation and Parks Commission |
| <input type="checkbox"/> Human Resources Commission           | <input type="checkbox"/> Senior Citizens Commission      |
| <input type="checkbox"/> Library Board of Trustees            | <input type="checkbox"/> Arcadia Health Commission       |

NAME Dale Carter DATE OF BIRTH (mm/dd/yyyy) [REDACTED]

FIRST LAST

RESIDENTIAL ADDRESS [REDACTED] Arcadia, CA 91006

(Note: Cannot be a mailing address or PO Box)

BUSINESS ADDRESS (HEALTH COMMISSION ONLY)

I CERTIFY THAT I AM A RESIDENT OF DISTRICT  ONE  TWO  THREE  FOUR  FIVE  
 N/A (Health Commission Only)

PHONE NUMBER [REDACTED] EMAIL ADDRESS [REDACTED]

OCCUPATION Retired engineer (mechanical not locomotive) EMPLOYER Retired

ARE YOU AN ARCADIA REGISTERED VOTER?  YES  NO

HOW LONG HAVE YOU BEEN A RESIDENT? (if Applicable) 60 years

PLEASE ANSWER THE QUESTIONS BELOW. YOU MAY USE ADDITIONAL SHEETS OF PAPER AS NECESSARY.

**EDUCATION (Include professional or vocational licenses of certificates)**

BSME, USC; MSME, USC; Retired registered CA Professional Engineer in Mechanical Engineering, and Control Systems Engineering

**COMMUNITY INVOLVEMENT (List organization memberships and committee assignments)**

Arcadia Museum Commission, 2014-2018, 2018-2022 (termed out), 2024-  
Volunteer at LA County Arboretum (various functions)  
2017 Arcadia Leadership Academy, Member of Arcadia Historical Society,

**PLEASE DESCRIBE ANY BACKGROUND, TRAINING, OR INTERESTS THAT QUALIFY YOU AS AN APPOINTEE**

Docent at the Santa Anita Depot at the Arboretum; Previous member of Volunteer Speakers Bureaus at the Arboretum and at the Gilb Museum giving talks on Arcadia and Arboretum history; in 2017 made a presentation at the dedication of Arcadia's History Lives Here Marker #11 at the Arcadia Transit Plaza (the marker contains a railroad diagram and a photograph of mine).

**WHAT INTERESTS YOU ABOUT THE BOARD/COMMISSION YOU ARE APPLYING FOR?**

I have been interested in the museum for years; I donated a couple of Arcadia depot photographs when it was a temporary building in back of the Community Center. The commission is a sounding board for discussions of existing and proposed museum exhibits, procedures, and activities, a place to make suggestions, and to help implement appropriate activities.

ARE YOU AWARE OF THE TIME COMMITMENT NECESSARY TO FULFILL THE OBLIGATIONS OF AN APPOINTMENT TO THIS POSITION?

YES  NO

NOTE: FOR LIBRARY BOARD OF TRUSTEE AND PLANNING COMMISSION APPLICATIONS ONLY  
STATE LAW AND THE CITY CONFLICT OF INTEREST CODE REQUIRES THAT LIBRARY BOARD OF TRUSTEE MEMBERS AND PLANNING COMMISSIONERS FILE A STATEMENT OF ECONOMIC INTERESTS (FORM 700) ANNUALLY AS WELL AS RELATED FORMS WHEN ASSUMING AND LEAVING OFFICE (e.g. sources of income, loans, gifts, investments, interest in real property as required by state law). DO YOU AGREE TO FILE ALL REQUIRED FORMS IN A TIMELY MANNER AS REQUIRED BY THE CITY'S FILING OFFICIAL?

YES  NO

---

**\*ARCADIA BEAUTIFUL APPLICANTS ONLY**

ARE YOU AWARE THAT THE PRIMARY FUNCTION OF THE ARCADIA BEAUTIFUL COMMISSION IS TO ACT AS JUDGES FOR THE COMMISSIONS AWARD PROGRAMS (Spring Home, Holiday Decoration, and Water Smart Hero awards)?

YES  NO

DO YOU HAVE THE ABILITY TO TRAVEL BY CAR DURING THE DAY AND IN THE EVENING FOR THE PURPOSE OF JUDGING?

YES  NO

THE ARCADIA BEAUTIFUL COMMISSION USUALLY HAS FOUR REGULAR MEETINGS EACH YEAR WITH ADDITIONAL MEETINGS AND/OR TIME COMMITMENTS SCHEDULED FOR THE PURPOSE OF CONDUCTING JUDGING FOR THE AWARD PROGRAMS, PARTICIPATING IN A 3-4 HOUR HOLIDAY DECORATION AWARD RECOGNITION EVENT, AND PARTICIPATING IN ARBOR DAY PROGRAMS. ADDITIONALLY, PRELIMINARY JUDGING FOR THE SPRING HOME AND HOLIDAY DECORATION AWARDS IS DONE WITH EACH COMMISSIONER TAKING RESPONSIBILITY FOR A SECTION OF THE CITY AND DRIVING THROUGH THE NEIGHBORHOODS TO SELECT THEIR NOMINATIONS FOR FINAL JUDGING BY THE COMMISSION. ARE YOU ABLE TO FULFILL THIS TIME COMMITMENT?

YES  NO

---

I HEREBY CERTIFY THAT THE FOREGOING INFORMATION IS TRUE AND CORRECT TO THE BEST OF MY KNOWLEDGE.



SIGNATURE

5/14/2026

DATE

NOTE: The City of Arcadia reserves the right to use the information provided on this application to verify your residential address and voter registration status. The information provided on this application is for internal use only and confidential information will not be released to the public.

PLEASE SUBMIT YOUR COMPLETED APPLICATION TO: CITY CLERK'S OFFICE  
240 W. HUNTINGTON DRIVE  
ARCADIA, CA 91007

OR

Email us at [CityClerk@ArcadiaCA.gov](mailto:CityClerk@ArcadiaCA.gov)

Questions? Please contact us at (626) 574-5455

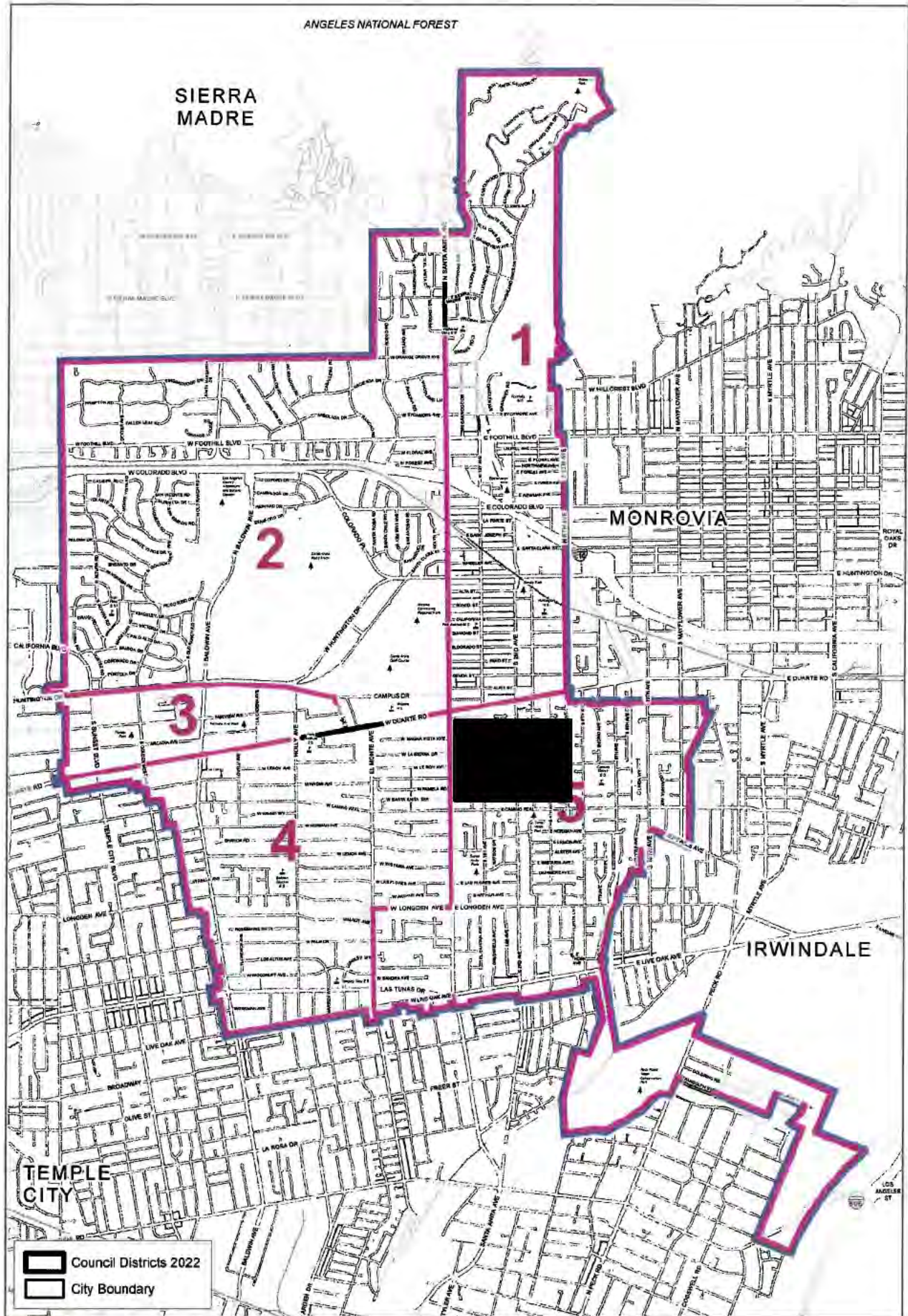

SIERRA MADRE



TEMPLE CITY

MONROVIA

IRWINDALE

 Council Districts 2022  
 City Boundary

**Council District**  
 City of Arcadia, California





# City of Arcadia Board/Commission Application

RECEIVED  
CITY OF ARCADIA

APR 12 2026

CITY MANAGER

PLEASE PLACE A CHECK MARK NEXT TO THE BOARD OR COMMISSION FOR WHICH YOU WOULD LIKE TO APPLY (more than one selection may be made):

- |   |  |
|---|--|
| <input type="checkbox"/> Arcadia Beautiful Commission*        | <input type="checkbox"/> Planning Commission             |
| <input checked="" type="checkbox"/> Arcadia Museum Commission | <input type="checkbox"/> Recreation and Parks Commission |
| <input type="checkbox"/> Human Resources Commission           | <input type="checkbox"/> Senior Citizens Commission      |
| <input type="checkbox"/> Library Board of Trustees            | <input type="checkbox"/> Arcadia Health Commission       |

NAME Ethel Laczko DATE OF BIRTH (mm/dd/yyyy) [REDACTED]

FIRST LAST RESIDENTIAL ADDRESS [REDACTED] Arcadia, CA. 91006

(Note: Cannot be a mailing address or PO Box)

BUSINESS ADDRESS (HEALTH COMMISSION ONLY) N/A

I CERTIFY THAT I AM A RESIDENT OF DISTRICT  ONE  TWO  THREE  FOUR  FIVE  
 N/A (Health Commission Only)

PHONE NUMBER [REDACTED] EMAIL ADDRESS [REDACTED]

OCCUPATION Executive Director-Global Education, Per. EMPLOYER Retired Teacher -Long Beach Unified School Dis

ARE YOU AN ARCADIA REGISTERED VOTER?  YES  NO

HOW LONG HAVE YOU BEEN A RESIDENT? (If Applicable) 36 years

PLEASE ANSWER THE QUESTIONS BELOW. YOU MAY USE ADDITIONAL SHEETS OF PAPER AS NECESSARY.

### EDUCATION (Include professional or vocational licenses or certificates)

1-National Board Certified Teacher, Master Teacher for Long Beach Unified School District, Harvard Graduate School of Education, was awarded the Fred Smith Award for Outstanding Service to the Harvard Club Of Southern California, Multiple Teaching Credentials in Elementary and in High School Education, Leadership Team Member for High School.

### COMMUNITY INVOLVEMENT (List organization memberships and committee assignments)

2-On Extra page -----

### PLEASE DESCRIBE ANY BACKGROUND, TRAINING, OR INTERESTS THAT QUALIFY YOU AS AN APPOINTEE

3-I love Museums and I have visited almost all Museums in the world including the Hermitage Museum in Russia. Arcadia has a rich past - from a ranch land and the legacy of the Baldwin family to a modern and diverse community. As a long time educator and a long time resident of Arcadia, I realize the importance of preserving the identity of the city, making the Museum an educational hub supporting arts and culture, and building community. The museum becomes a cultural and economic asset.

### WHAT INTERESTS YOU ABOUT THE BOARD/COMMISSION YOU ARE APPLYING FOR?

4-As a long time educator and a long time resident of Arcadia, I realize the importance of preserving the identity of the city, making the Museum an educational hub supporting arts and culture, and building community.

ARE YOU AWARE OF THE TIME COMMITMENT NECESSARY TO FULFILL THE OBLIGATIONS OF AN APPOINTMENT TO THIS POSITION?

YES  NO

NOTE: FOR LIBRARY BOARD OF TRUSTEE AND PLANNING COMMISSION APPLICATIONS ONLY  
STATE LAW AND THE CITY CONFLICT OF INTEREST CODE REQUIRES THAT LIBRARY BOARD OF TRUSTEE MEMBERS AND PLANNING COMMISSIONERS FILE A STATEMENT OF ECONOMIC INTERESTS (FORM 700) ANNUALLY AS WELL AS RELATED FORMS WHEN ASSUMING AND LEAVING OFFICE (e.g. sources of income, loans, gifts, investments, interest in real property as required by state law). DO YOU AGREE TO FILE ALL REQUIRED FORMS IN A TIMELY MANNER AS REQUIRED BY THE CITY'S FILING OFFICIAL?

YES  NO

---

**\*ARCADIA BEAUTIFUL APPLICANTS ONLY**

ARE YOU AWARE THAT THE PRIMARY FUNCTION OF THE ARCADIA BEAUTIFUL COMMISSION IS TO ACT AS JUDGES FOR THE COMMISSIONS AWARD PROGRAMS (Spring Home, Holiday Decoration, and Water Smart Hero awards)?

YES  NO

DO YOU HAVE THE ABILITY TO TRAVEL BY CAR DURING THE DAY AND IN THE EVENING FOR THE PURPOSE OF JUDGING?

YES  NO

THE ARCADIA BEAUTIFUL COMMISSION USUALLY HAS FOUR REGULAR MEETINGS EACH YEAR WITH ADDITIONAL MEETINGS AND/OR TIME COMMITMENTS SCHEDULED FOR THE PURPOSE OF CONDUCTING JUDGING FOR THE AWARD PROGRAMS, PARTICIPATING IN A 3-4 HOUR HOLIDAY DECORATION AWARD RECOGNITION EVENT, AND PARTICIPATING IN ARBOR DAY PROGRAMS. ADDITIONALLY, PRELIMINARY JUDGING FOR THE SPRING HOME AND HOLIDAY DECORATION AWARDS IS DONE WITH EACH COMMISSIONER TAKING RESPONSIBILITY FOR A SECTION OF THE CITY AND DRIVING THROUGH THE NEIGHBORHOODS TO SELECT THEIR NOMINATIONS FOR FINAL JUDGING BY THE COMMISSION. ARE YOU ABLE TO FULFILL THIS TIME COMMITMENT?

YES  NO

---

I HEREBY CERTIFY THAT THE FOREGOING INFORMATION IS TRUE AND CORRECT TO THE BEST OF MY KNOWLEDGE.

  
SIGNATURE

April 6, 2026

DATE

NOTE: The City of Arcadia reserves the right to use the information provided on this application to verify your residential address and voter registration status. The information provided on this application is for internal use only and confidential information will not be released to the public.

PLEASE SUBMIT YOUR COMPLETED APPLICATION TO: CITY CLERK'S OFFICE  
240 W. HUNTINGTON DRIVE  
ARCADIA, CA 91007

OR

Email us at [CityClerk@ArcadiaCA.gov](mailto:CityClerk@ArcadiaCA.gov)

Questions? Please contact us at (626) 574-5455

Ethel Laczko

Application 2026- Commissioner

**Question # 2- Community Involvement-**

Completed the City of Arcadia's civic education program on how all city departments operate. Served for 10 years on the Arcadia Beautiful Commission, where I actively recruited and coordinated volunteers to support community initiatives. Served for 2 years on the Senior Commission, where I established (first time) a partnership with Pasadena City College (PCC), bringing two free classes to seniors: *Sewing* and *History of Western Art Appreciation*. Additionally, I established partnerships with Pavilions (Naomi) and EOS Fitness to expand the reach of the Seniors' newsletter of activities, *Connections*, making it more accessible to a broader community. Led and coordinated a citywide initiative in collaboration with Arcadia High School and the Arcadia Historical Society, celebrating the city's heritage and fostering community engagement. (Postponed for 2027) Facilitated community enrichment by inviting a trustee from Pasadena City College to visit the Senior Center and by hosting a guest speaker—one of the Benefit Co- Chairs of the Pasadena Showcase House for the Arts—to present to members of the Travelers Club, highlighting the featured showcase home, the Clara Baldwin Stocker House.

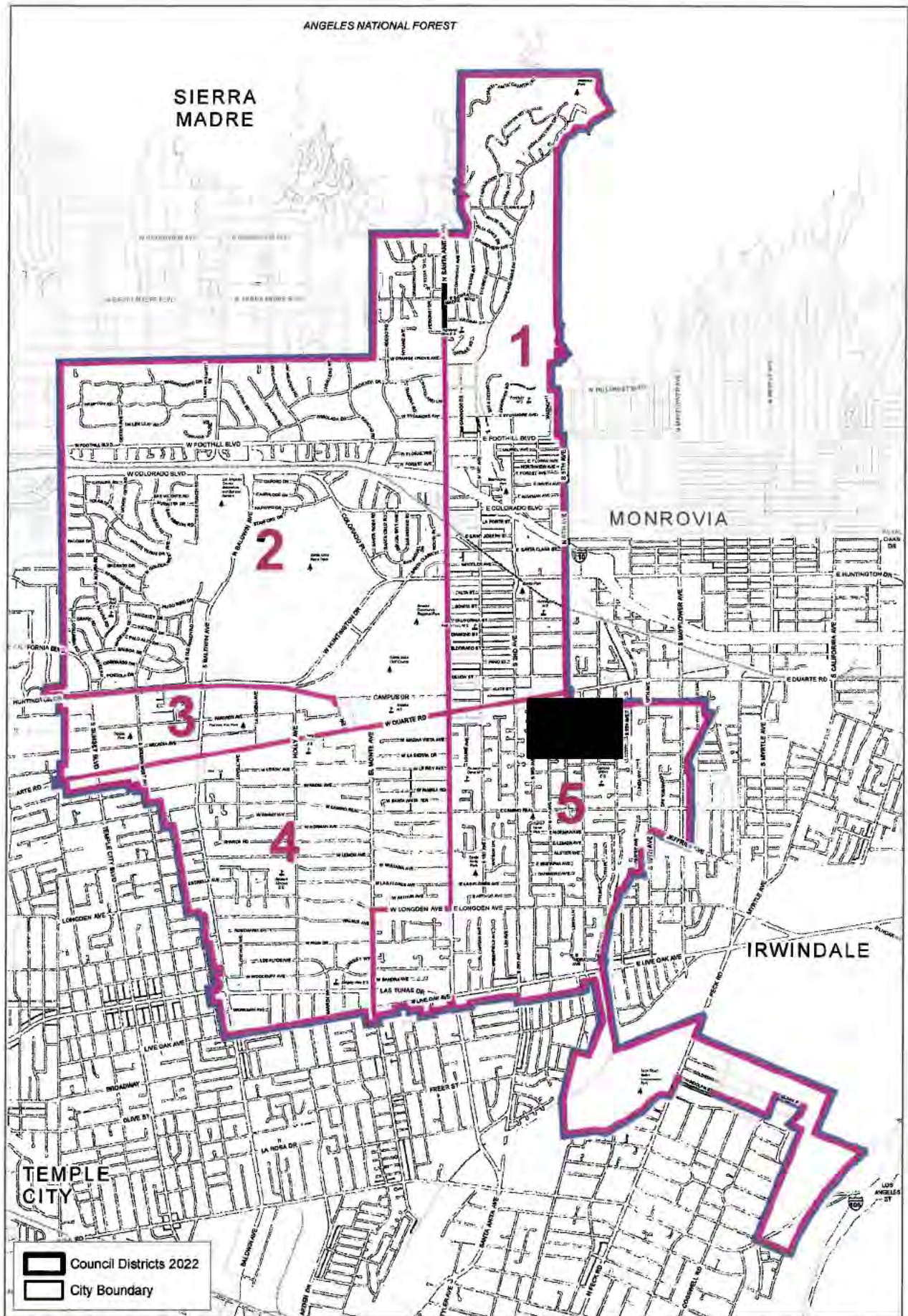

**Council District**  
**City of Arcadia, California**

**HUMAN RESOURCES  
COMMISSION  
APPLICANTS**



# City of Arcadia Board/Commission Application

RECEIVED

MAR 26 2026

CITY OF ARCADIA  
CITY CLERK

PLEASE PLACE A CHECK MARK NEXT TO THE BOARD OR COMMISSION FOR WHICH YOU WOULD LIKE TO APPLY (more than one selection may be made):

- |  |  |
|--|--|
| <input type="checkbox"/> Arcadia Beautiful Commission*         | <input type="checkbox"/> Planning Commission             |
| <input type="checkbox"/> Arcadia Museum Commission             | <input type="checkbox"/> Recreation and Parks Commission |
| <input checked="" type="checkbox"/> Human Resources Commission | <input type="checkbox"/> Senior Citizens Commission      |
| <input type="checkbox"/> Library Board of Trustees             | <input type="checkbox"/> Arcadia Health Commission       |

NAME William Hsu DATE OF BIRTH (mm/dd/yyyy) [REDACTED]

FIRST LAST

RESIDENTIAL ADDRESS [REDACTED] Arcadia, CA 91007

(Note: Cannot be a mailing address or PO Box)

BUSINESS ADDRESS (HEALTH COMMISSION ONLY) \_\_\_\_\_

I CERTIFY THAT I AM A RESIDENT OF DISTRICT  ONE  TWO  THREE  FOUR  FIVE  
 N/A (Health Commission Only)

PHONE NUMBER [REDACTED] EMAIL ADDRESS [REDACTED]

OCCUPATION Electrical Engineering Associate EMPLOYER Los Angeles Department of Water and Power

ARE YOU AN ARCADIA REGISTERED VOTER?  YES  NO

HOW LONG HAVE YOU BEEN A RESIDENT? (If Applicable) 21

PLEASE ANSWER THE QUESTIONS BELOW. YOU MAY USE ADDITIONAL SHEETS OF PAPER AS NECESSARY.

### EDUCATION (Include professional or vocational licenses or certificates)

K-12: Arcadia public school (2016); B.S. in Electrical Engineering: Cal Poly SLO (2020);  
M.S. in Electrical Engineering: Missouri S&T (2024); MBA: USC (2027); Professional Engineer License (E 26186)

### COMMUNITY INVOLVEMENT (List organization memberships and committee assignments)

LADWP VALOR (Veteran's Alliance for Leadership, Outreach, and Recognition; LADWP Green Team  
IEEE since 2016; Cal Poly Power & Energy Society (2019-2020)  
President and Founder of recreational clubs at Cal Poly SLO and Missouri S&T  
Council Member of the Intercollegiate Tournament League (disbanded in 2026)

### PLEASE DESCRIBE ANY BACKGROUND, TRAINING, OR INTERESTS THAT QUALIFY YOU AS AN APPOINTEE

Being raised in Arcadia, I would like to give back to the community now that I am able. I have founded and been president for a recreational club for table top gaming during my time in Cal Poly SLO and later Missouri S&T. Out of necessity initially, I had learned how to lead and manage students and officially recognized organizations that still are thriving today. In 2021, I had joined the U.S. Army and currently serve as an Engineer Officer in the reserves. As an officer, I am naturally put in leadership positions and have been currently serving as the company commander to my unit in Missouri for over 2 years.

### WHAT INTERESTS YOU ABOUT THE BOARD/COMMISSION YOU ARE APPLYING FOR?

I am interested in the Human Resources Commission because I have experience as a company commander working with the administrative demands and needs of my soldiers and personnel. While I understand that the military process is likely vastly different from the civilian side, my experience will prepare me to learn any necessary skills for the commission. My interests in doing my community service started when I was young, and I kept finding myself in positions where I am helping uplift and support others succeed around me. It wasn't until I self-reflected after finishing my master's program in 2024 when I realized that I enjoyed serving others for a greater purpose, whether it be in the Army, city utilities, or organizations.

ARE YOU AWARE OF THE TIME COMMITMENT NECESSARY TO FULFILL THE OBLIGATIONS OF AN APPOINTMENT TO THIS POSITION?

YES  NO

NOTE: FOR LIBRARY BOARD OF TRUSTEE AND PLANNING COMMISSION APPLICATIONS ONLY  
STATE LAW AND THE CITY CONFLICT OF INTEREST CODE REQUIRES THAT LIBRARY BOARD OF TRUSTEE MEMBERS AND PLANNING COMMISSIONERS FILE A STATEMENT OF ECONOMIC INTERESTS (FORM 700) ANNUALLY AS WELL AS RELATED FORMS WHEN ASSUMING AND LEAVING OFFICE (e.g. sources of income, loans, gifts, investments, interest in real property as required by state law). DO YOU AGREE TO FILE ALL REQUIRED FORMS IN A TIMELY MANNER AS REQUIRED BY THE CITY'S FILING OFFICIAL?

YES  NO

---

**\*ARCADIA BEAUTIFUL APPLICANTS ONLY**

ARE YOU AWARE THAT THE PRIMARY FUNCTION OF THE ARCADIA BEAUTIFUL COMMISSION IS TO ACT AS JUDGES FOR THE COMMISSIONS AWARD PROGRAMS (Spring Home, Holiday Decoration, and Water Smart Hero awards)?

YES  NO

DO YOU HAVE THE ABILITY TO TRAVEL BY CAR DURING THE DAY AND IN THE EVENING FOR THE PURPOSE OF JUDGING?

YES  NO

THE ARCADIA BEAUTIFUL COMMISSION USUALLY HAS FOUR REGULAR MEETINGS EACH YEAR WITH ADDITIONAL MEETINGS AND/OR TIME COMMITMENTS SCHEDULED FOR THE PURPOSE OF CONDUCTING JUDGING FOR THE AWARD PROGRAMS, PARTICIPATING IN A 3-4 HOUR HOLIDAY DECORATION AWARD RECOGNITION EVENT, AND PARTICIPATING IN ARBOR DAY PROGRAMS. ADDITIONALLY, PRELIMINARY JUDGING FOR THE SPRING HOME AND HOLIDAY DECORATION AWARDS IS DONE WITH EACH COMMISSIONER TAKING RESPONSIBILITY FOR A SECTION OF THE CITY AND DRIVING THROUGH THE NEIGHBORHOODS TO SELECT THEIR NOMINATIONS FOR FINAL JUDGING BY THE COMMISSION. ARE YOU ABLE TO FULFILL THIS TIME COMMITMENT?

YES  NO

---

I HEREBY CERTIFY THAT THE FOREGOING INFORMATION IS TRUE AND CORRECT TO THE BEST OF MY KNOWLEDGE.

William Hsu



03/26/2026

SIGNATURE

DATE

NOTE: The City of Arcadia reserves the right to use the information provided on this application to verify your residential address and voter registration status. The information provided on this application is for internal use only and confidential information will not be released to the public.

PLEASE SUBMIT YOUR COMPLETED APPLICATION TO: CITY CLERK'S OFFICE  
240 W. HUNTINGTON DRIVE  
ARCADIA, CA 91007

OR

Email us at [CityClerk@ArcadiaCA.gov](mailto:CityClerk@ArcadiaCA.gov)

Questions? Please contact us at (626) 574-5455

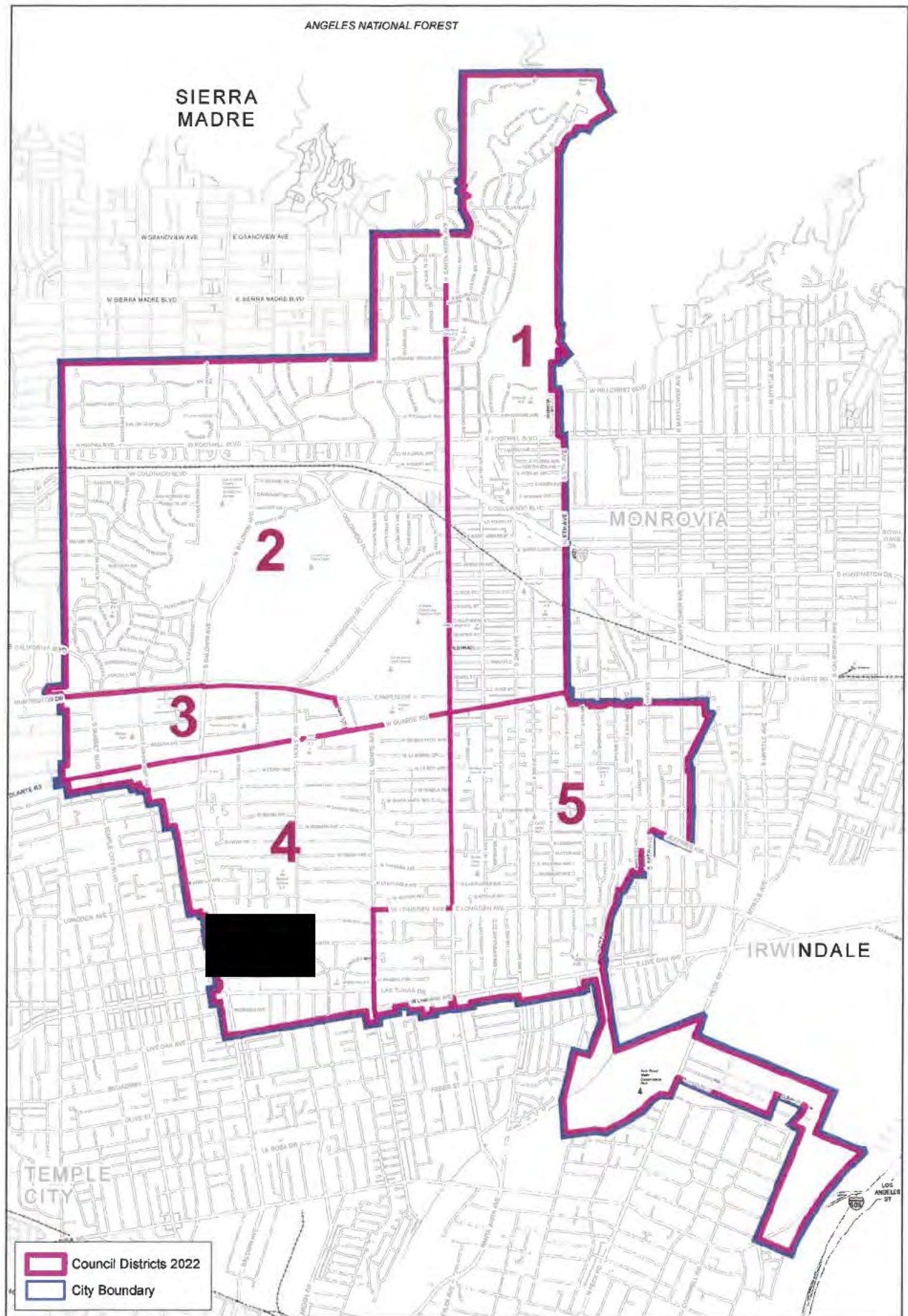

**Council District**  
**City of Arcadia, California**



# City of Arcadia Board/Commission Application

RECEIVED  
CITY OF ARCADIA

MAR 16 2026

CITY MANAGER

PLEASE PLACE A CHECK MARK NEXT TO THE BOARD OR COMMISSION FOR WHICH YOU WOULD LIKE TO APPLY (more than one selection may be made):

- |   |   |
|---|---|
| <input checked="" type="checkbox"/> Arcadia Beautiful Commission* | <input checked="" type="checkbox"/> Planning Commission             |
| <input type="checkbox"/> Arcadia Museum Commission                | <input checked="" type="checkbox"/> Recreation and Parks Commission |
| <input checked="" type="checkbox"/> Human Resources Commission    | <input checked="" type="checkbox"/> Senior Citizens Commission      |
| <input checked="" type="checkbox"/> Library Board of Trustees     | <input type="checkbox"/> Arcadia Health Commission                  |

NAME JOHNNY TSENG DATE OF BIRTH (mm/dd/yyyy) [REDACTED]

FIRST LAST

RESIDENTIAL ADDRESS [REDACTED] 91006

(Note: Cannot be a mailing address or PO Box)

BUSINESS ADDRESS (HEALTH COMMISSION ONLY) \_\_\_\_\_

I CERTIFY THAT I AM A RESIDENT OF DISTRICT  ONE  TWO  THREE  FOUR  FIVE  
 N/A (Health Commission Only)

PHONE NUMBER [REDACTED] EMAIL ADDRESS [REDACTED]

OCCUPATION Teacher EMPLOYER Hacienda La Puente Unified School District

ARE YOU AN ARCADIA REGISTERED VOTER?  YES  NO

HOW LONG HAVE YOU BEEN A RESIDENT? (If Applicable) 19

PLEASE ANSWER THE QUESTIONS BELOW. YOU MAY USE ADDITIONAL SHEETS OF PAPER AS NECESSARY.

**EDUCATION (Include professional or vocational licenses or certificates)**  
Active Community Member, Interest in community service, betterment of the City of Arcadia, and highly enthusiastic and involved. Would be amazing to have this opportunity to make a difference.

**COMMUNITY INVOLVEMENT (List organization memberships and committee assignments)**  
Active Community Member, Interest in community service, betterment of the City of Arcadia, and highly enthusiastic and involved. Would be amazing to have this opportunity to make a difference.

**PLEASE DESCRIBE ANY BACKGROUND, TRAINING, OR INTERESTS THAT QUALIFY YOU AS AN APPOINTEE**  
Active Community Member, Interest in community service, betterment of the City of Arcadia, and highly enthusiastic and involved. Would be amazing to have this opportunity to make a difference.

**WHAT INTERESTS YOU ABOUT THE BOARD/COMMISSION YOU ARE APPLYING FOR?**  
Active Community Member, Interest in community service, betterment of the City of Arcadia, and highly enthusiastic and involved. Would be amazing to have this opportunity to make a difference.

ARE YOU AWARE OF THE TIME COMMITMENT NECESSARY TO FULFILL THE OBLIGATIONS OF AN APPOINTMENT TO THIS POSITION?

YES  NO

NOTE: FOR LIBRARY BOARD OF TRUSTEE AND PLANNING COMMISSION APPLICATIONS ONLY  
STATE LAW AND THE CITY CONFLICT OF INTEREST CODE REQUIRES THAT LIBRARY BOARD OF TRUSTEE MEMBERS AND PLANNING COMMISSIONERS FILE A STATEMENT OF ECONOMIC INTERESTS (FORM 700) ANNUALLY AS WELL AS RELATED FORMS WHEN ASSUMING AND LEAVING OFFICE (e.g. sources of income, loans, gifts, investments, interest in real property as required by state law). DO YOU AGREE TO FILE ALL REQUIRED FORMS IN A TIMELY MANNER AS REQUIRED BY THE CITY'S FILING OFFICIAL?

YES  NO

**\*ARCADIA BEAUTIFUL APPLICANTS ONLY**

ARE YOU AWARE THAT THE PRIMARY FUNCTION OF THE ARCADIA BEAUTIFUL COMMISSION IS TO ACT AS JUDGES FOR THE COMMISSIONS AWARD PROGRAMS (Spring Home, Holiday Decoration, and Water Smart Hero awards)?

YES  NO

DO YOU HAVE THE ABILITY TO TRAVEL BY CAR DURING THE DAY AND IN THE EVENING FOR THE PURPOSE OF JUDGING?

YES  NO

THE ARCADIA BEAUTIFUL COMMISSION USUALLY HAS FOUR REGULAR MEETINGS EACH YEAR WITH ADDITIONAL MEETINGS AND/OR TIME COMMITMENTS SCHEDULED FOR THE PURPOSE OF CONDUCTING JUDGING FOR THE AWARD PROGRAMS, PARTICIPATING IN A 3-4 HOUR HOLIDAY DECORATION AWARD RECOGNITION EVENT, AND PARTICIPATING IN ARBOR DAY PROGRAMS. ADDITIONALLY, PRELIMINARY JUDGING FOR THE SPRING HOME AND HOLIDAY DECORATION AWARDS IS DONE WITH EACH COMMISSIONER TAKING RESPONSIBILITY FOR A SECTION OF THE CITY AND DRIVING THROUGH THE NEIGHBORHOODS TO SELECT THEIR NOMINATIONS FOR FINAL JUDGING BY THE COMMISSION. ARE YOU ABLE TO FULFILL THIS TIME COMMITMENT?

YES  NO

I HEREBY CERTIFY THAT THE INFORMATION IS TRUE AND CORRECT TO THE BEST OF MY KNOWLEDGE.



3-6-26  
DATE

NOTE: The City of Arcadia reserves the right to use the information provided on this application to verify your residential address and voter registration status. The information provided on this application is for internal use only and confidential information will not be released to the public.

PLEASE SUBMIT YOUR COMPLETED APPLICATION TO: CITY CLERK'S OFFICE  
240 W. HUNTINGTON DRIVE  
ARCADIA, CA 91007

OR

Email us at [CityClerk@ArcadiaCA.gov](mailto:CityClerk@ArcadiaCA.gov)

Questions? Please contact us at (626) 574-5455

CITY CLERK'S OFFICE  
240 W. HUNTINGTON DRIVE ARCADIA, CA 91007

City Clerk's Office  
City of Arcadia  
P. O. Box 60021  
Arcadia, California 91066

Masters in Arts- Educational Leadership  
Bachelor's in Arts- Child Development

**Arcadia High School Orchestra Benefit Dinner Committee Chair, San Marino Chinese School Board Member, AHS Hispanic Parent Booster Club Vice President, Arcadia Troop 104/333 Assistant Scout Master, Arcadia Citizens Oversight Committee Member. Arcadia Neighborhood Watch Captain**

**Active Community Member, Interest in community service, betterment of the City of Arcadia, and highly enthusiastic and involved. Would be amazing to have this opportunity to make a difference.**

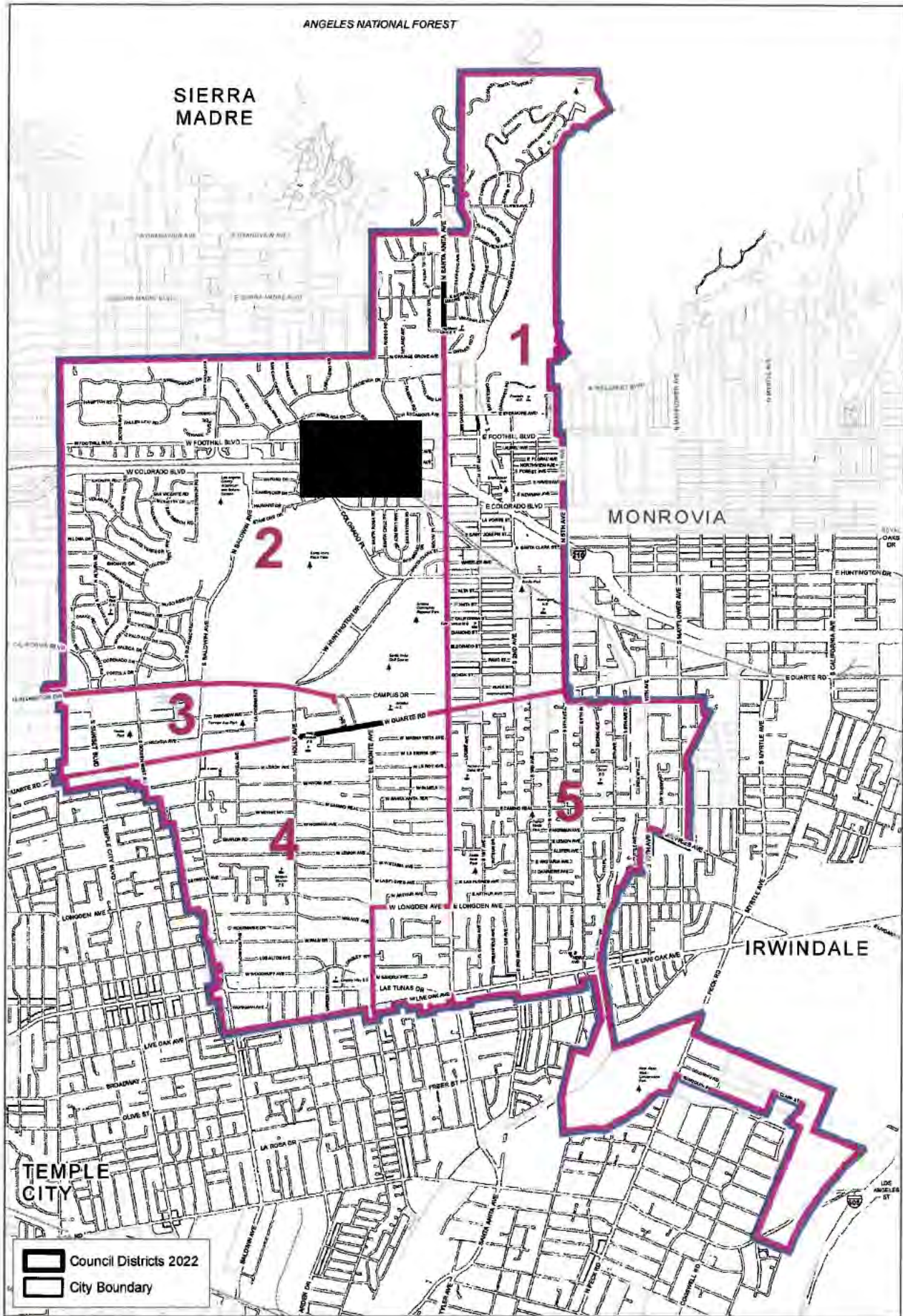

SIERRA MADRE



TEMPLE CITY

MONROVIA

IRWINDALE

 Council Districts 2022  
 City Boundary

**Council District**  
 City of Arcadia, California



# City of Arcadia Board/Commission Application

RECEIVED

APR 20 2026

PLEASE PLACE A CHECK MARK NEXT TO THE BOARD OR COMMISSION FOR WHICH YOU WOULD LIKE TO APPLY (more than one selection may be made):

CITY CLERK

- |  |   |
|--|---|
| <input type="checkbox"/> Arcadia Beautiful Commission*         | <input type="checkbox"/> Planning Commission                        |
| <input type="checkbox"/> Arcadia Museum Commission             | <input checked="" type="checkbox"/> Recreation and Parks Commission |
| <input checked="" type="checkbox"/> Human Resources Commission | <input type="checkbox"/> Senior Citizens Commission                 |
| <input type="checkbox"/> Library Board of Trustees             | <input type="checkbox"/> Arcadia Health Commission                  |

NAME Kenneth Proulx DATE OF BIRTH (mm/dd/yyyy) [REDACTED]  
FIRST LAST

RESIDENTIAL ADDRESS [REDACTED] Arcadia, CA, 91006

(Note: Cannot be a mailing address or PO Box)

BUSINESS ADDRESS (HEALTH COMMISSION ONLY) \_\_\_\_\_

I CERTIFY THAT I AM A RESIDENT OF DISTRICT  ONE  TWO  THREE  FOUR  FIVE  
 N/A (Health Commission Only)

PHONE NUMBER [REDACTED] EMAIL ADDRESS [REDACTED]

OCCUPATION Executive EMPLOYER KP Consulting Group LLC

ARE YOU AN ARCADIA REGISTERED VOTER?  YES  NO

HOW LONG HAVE YOU BEEN A RESIDENT? (If Applicable) 18 years

PLEASE ANSWER THE QUESTIONS BELOW. YOU MAY USE ADDITIONAL SHEETS OF PAPER AS NECESSARY.

**EDUCATION (Include professional or vocational licenses or certificates)**

- Master's degree, Stanford University Graduate School of Business
- Bachelor's degree, UC Irvine

**COMMUNITY INVOLVEMENT (List organization memberships and committee assignments)**

President and Vice President of the School Site Councils (SSC) at Camino Grove Elementary School and Dana Middle School for 10+ years. Community representative at Local Control and Accountability Plan (LCAP) Stakeholder Meetings in 2025. Parade Director for Dana Middle School in the 2025-2026 school year.

**PLEASE DESCRIBE ANY BACKGROUND, TRAINING, OR INTERESTS THAT QUALIFY YOU AS AN APPOINTEE**

Top-tier education in HR, finance, leadership, operations through Master's degree program at Stanford University Graduate School of Business. Leadership and management experience useful to HR Commissions gained as C-level executive managing 17K+ people in 14 countries. As a pickleball and tennis player in Arcadia, I am familiar with courts, park facilities, and resource issues that are pertinent to the Recreation and Parks Commission.

**WHAT INTERESTS YOU ABOUT THE BOARD/COMMISSION YOU ARE APPLYING FOR?**

I have a track record of volunteerism within the Arcadia Unified School District and am in tune to the changes that Arcadia has been going through since I moved here in January 2008. I am volunteering because I have relevant skills and experience and leadership experience that I know I can leverage to help improve our Arcadia community. I want to make a positive difference and help Arcadia run smoothly and serve its citizens to the best extent possible.

ARE YOU AWARE OF THE TIME COMMITMENT NECESSARY TO FULFILL THE OBLIGATIONS OF AN APPOINTMENT TO THIS POSITION?

YES  NO

NOTE: FOR LIBRARY BOARD OF TRUSTEE AND PLANNING COMMISSION APPLICATIONS ONLY  
STATE LAW AND THE CITY CONFLICT OF INTEREST CODE REQUIRES THAT LIBRARY BOARD OF TRUSTEE MEMBERS AND PLANNING COMMISSIONERS FILE A STATEMENT OF ECONOMIC INTERESTS (FORM 700) ANNUALLY AS WELL AS RELATED FORMS WHEN ASSUMING AND LEAVING OFFICE (e.g. sources of income, loans, gifts, investments, interest in real property as required by state law). DO YOU AGREE TO FILE ALL REQUIRED FORMS IN A TIMELY MANNER AS REQUIRED BY THE CITY'S FILING OFFICIAL?

YES  NO

---

**\*ARCADIA BEAUTIFUL APPLICANTS ONLY**

ARE YOU AWARE THAT THE PRIMARY FUNCTION OF THE ARCADIA BEAUTIFUL COMMISSION IS TO ACT AS JUDGES FOR THE COMMISSIONS AWARD PROGRAMS (Spring Home, Holiday Decoration, and Water Smart Hero awards)?

YES  NO

DO YOU HAVE THE ABILITY TO TRAVEL BY CAR DURING THE DAY AND IN THE EVENING FOR THE PURPOSE OF JUDGING?

YES  NO

THE ARCADIA BEAUTIFUL COMMISSION USUALLY HAS FOUR REGULAR MEETINGS EACH YEAR WITH ADDITIONAL MEETINGS AND/OR TIME COMMITMENTS SCHEDULED FOR THE PURPOSE OF CONDUCTING JUDGING FOR THE AWARD PROGRAMS, PARTICIPATING IN A 3-4 HOUR HOLIDAY DECORATION AWARD RECOGNITION EVENT, AND PARTICIPATING IN ARBOR DAY PROGRAMS. ADDITIONALLY, PRELIMINARY JUDGING FOR THE SPRING HOME AND HOLIDAY DECORATION AWARDS IS DONE WITH EACH COMMISSIONER TAKING RESPONSIBILITY FOR A SECTION OF THE CITY AND DRIVING THROUGH THE NEIGHBORHOODS TO SELECT THEIR NOMINATIONS FOR FINAL JUDGING BY THE COMMISSION. ARE YOU ABLE TO FULFILL THIS TIME COMMITMENT?

YES  NO

---

I HEREBY CERTIFY THAT THE FOREGOING INFORMATION IS TRUE AND CORRECT TO THE BEST OF MY KNOWLEDGE.



SIGNATURE

4/18/2026

DATE

NOTE: The City of Arcadia reserves the right to use the information provided on this application to verify your residential address and voter registration status. The information provided on this application is for internal use only and confidential information will not be released to the public.

PLEASE SUBMIT YOUR COMPLETED APPLICATION TO: CITY CLERK'S OFFICE  
240 W. HUNTINGTON DRIVE  
ARCADIA, CA 91007

OR

Email us at [CityClerk@ArcadiaCA.gov](mailto:CityClerk@ArcadiaCA.gov)

Questions? Please contact us at (626) 574-5455

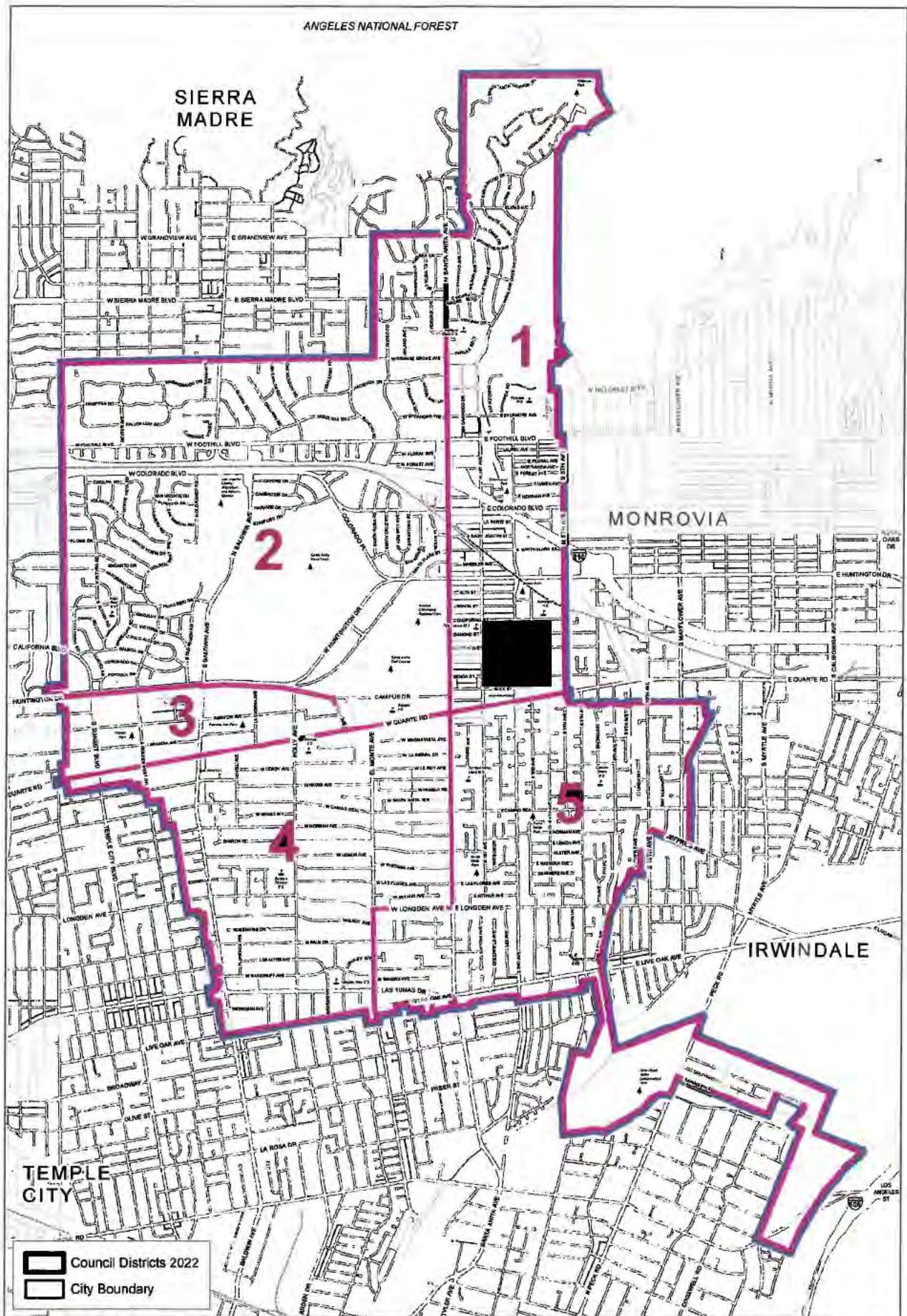

**Council District**  
*City of Arcadia, California*

# **LIBRARY BOARD OF TRUSTEES APPLICANTS**



# City of Arcadia Board/Commission Application

RECEIVED  
CITY OF ARCADIA

MAR 16 2026

CITY MANAGER

PLEASE PLACE A CHECK MARK NEXT TO THE BOARD OR COMMISSION FOR WHICH YOU WOULD LIKE TO APPLY (more than one selection may be made):

- |   |   |
|---|---|
| <input checked="" type="checkbox"/> Arcadia Beautiful Commission* | <input checked="" type="checkbox"/> Planning Commission             |
| <input type="checkbox"/> Arcadia Museum Commission                | <input checked="" type="checkbox"/> Recreation and Parks Commission |
| <input checked="" type="checkbox"/> Human Resources Commission    | <input checked="" type="checkbox"/> Senior Citizens Commission      |
| <input checked="" type="checkbox"/> Library Board of Trustees     | <input type="checkbox"/> Arcadia Health Commission                  |

NAME JOHNNY TSENG DATE OF BIRTH (mm/dd/yyyy) [REDACTED]

FIRST LAST

RESIDENTIAL ADDRESS [REDACTED] 91006

(Note: Cannot be a mailing address or PO Box)

BUSINESS ADDRESS (HEALTH COMMISSION ONLY) \_\_\_\_\_

I CERTIFY THAT I AM A RESIDENT OF DISTRICT  ONE  TWO  THREE  FOUR  FIVE  
 N/A (Health Commission Only)

PHONE NUMBER [REDACTED] EMAIL ADDRESS [REDACTED]

OCCUPATION Teacher EMPLOYER Hacienda La Puente Unified School District

ARE YOU AN ARCADIA REGISTERED VOTER?  YES  NO

HOW LONG HAVE YOU BEEN A RESIDENT? (If Applicable) 19

PLEASE ANSWER THE QUESTIONS BELOW. YOU MAY USE ADDITIONAL SHEETS OF PAPER AS NECESSARY.

**EDUCATION (Include professional or vocational licenses or certificates)**

Active Community Member, Interest in community service, betterment of the City of Arcadia, and highly enthusiastic and involved. Would be amazing to have this opportunity to make a difference.

**COMMUNITY INVOLVEMENT (List organization memberships and committee assignments)**

Active Community Member, Interest in community service, betterment of the City of Arcadia, and highly enthusiastic and involved. Would be amazing to have this opportunity to make a difference.

**PLEASE DESCRIBE ANY BACKGROUND, TRAINING, OR INTERESTS THAT QUALIFY YOU AS AN APPOINTEE**

Active Community Member, Interest in community service, betterment of the City of Arcadia, and highly enthusiastic and involved. Would be amazing to have this opportunity to make a difference.

**WHAT INTERESTS YOU ABOUT THE BOARD/COMMISSION YOU ARE APPLYING FOR?**

Active Community Member, Interest in community service, betterment of the City of Arcadia, and highly enthusiastic and involved. Would be amazing to have this opportunity to make a difference.

ARE YOU AWARE OF THE TIME COMMITMENT NECESSARY TO FULFILL THE OBLIGATIONS OF AN APPOINTMENT TO THIS POSITION?

YES  NO

NOTE: FOR LIBRARY BOARD OF TRUSTEE AND PLANNING COMMISSION APPLICATIONS ONLY  
STATE LAW AND THE CITY CONFLICT OF INTEREST CODE REQUIRES THAT LIBRARY BOARD OF TRUSTEE MEMBERS AND PLANNING COMMISSIONERS FILE A STATEMENT OF ECONOMIC INTERESTS (FORM 700) ANNUALLY AS WELL AS RELATED FORMS WHEN ASSUMING AND LEAVING OFFICE (e.g. sources of income, loans, gifts, investments, interest in real property as required by state law). DO YOU AGREE TO FILE ALL REQUIRED FORMS IN A TIMELY MANNER AS REQUIRED BY THE CITY'S FILING OFFICIAL?

YES  NO

**\*ARCADIA BEAUTIFUL APPLICANTS ONLY**

ARE YOU AWARE THAT THE PRIMARY FUNCTION OF THE ARCADIA BEAUTIFUL COMMISSION IS TO ACT AS JUDGES FOR THE COMMISSIONS AWARD PROGRAMS (Spring Home, Holiday Decoration, and Water Smart Hero awards)?

YES  NO

DO YOU HAVE THE ABILITY TO TRAVEL BY CAR DURING THE DAY AND IN THE EVENING FOR THE PURPOSE OF JUDGING?

YES  NO

THE ARCADIA BEAUTIFUL COMMISSION USUALLY HAS FOUR REGULAR MEETINGS EACH YEAR WITH ADDITIONAL MEETINGS AND/OR TIME COMMITMENTS SCHEDULED FOR THE PURPOSE OF CONDUCTING JUDGING FOR THE AWARD PROGRAMS, PARTICIPATING IN A 3-4 HOUR HOLIDAY DECORATION AWARD RECOGNITION EVENT, AND PARTICIPATING IN ARBOR DAY PROGRAMS. ADDITIONALLY, PRELIMINARY JUDGING FOR THE SPRING HOME AND HOLIDAY DECORATION AWARDS IS DONE WITH EACH COMMISSIONER TAKING RESPONSIBILITY FOR A SECTION OF THE CITY AND DRIVING THROUGH THE NEIGHBORHOODS TO SELECT THEIR NOMINATIONS FOR FINAL JUDGING BY THE COMMISSION. ARE YOU ABLE TO FULFILL THIS TIME COMMITMENT?

YES  NO

I HEREBY CERTIFY THAT THE INFORMATION IS TRUE AND CORRECT TO THE BEST OF MY KNOWLEDGE.

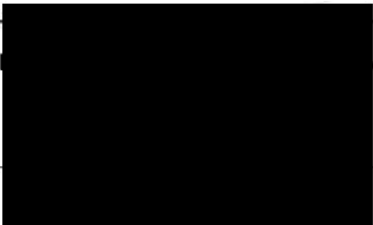

3-6-26  
DATE

NOTE: The City of Arcadia reserves the right to use the information provided on this application to verify your residential address and voter registration status. The information provided on this application is for internal use only and confidential information will not be released to the public.

PLEASE SUBMIT YOUR COMPLETED APPLICATION TO: CITY CLERK'S OFFICE  
240 W. HUNTINGTON DRIVE  
ARCADIA, CA 91007

OR

Email us at [CityClerk@ArcadiaCA.gov](mailto:CityClerk@ArcadiaCA.gov)

Questions? Please contact us at (626) 574-5455

CITY CLERK'S OFFICE  
240 W. HUNTINGTON DRIVE ARCADIA, CA 91007

City Clerk's Office  
City of Arcadia  
P. O. Box 60021  
Arcadia, California 91066

Masters in Arts- Educational Leadership  
Bachelor's in Arts- Child Development

**Arcadia High School Orchestra Benefit Dinner Committee Chair, San Marino Chinese School Board Member, AHS Hispanic Parent Booster Club Vice President, Arcadia Troop 104/333 Assistant Scout Master, Arcadia Citizens Oversight Committee Member. Arcadia Neighborhood Watch Captain**

**Active Community Member, Interest in community service, betterment of the City of Arcadia, and highly enthusiastic and involved. Would be amazing to have this opportunity to make a difference.**

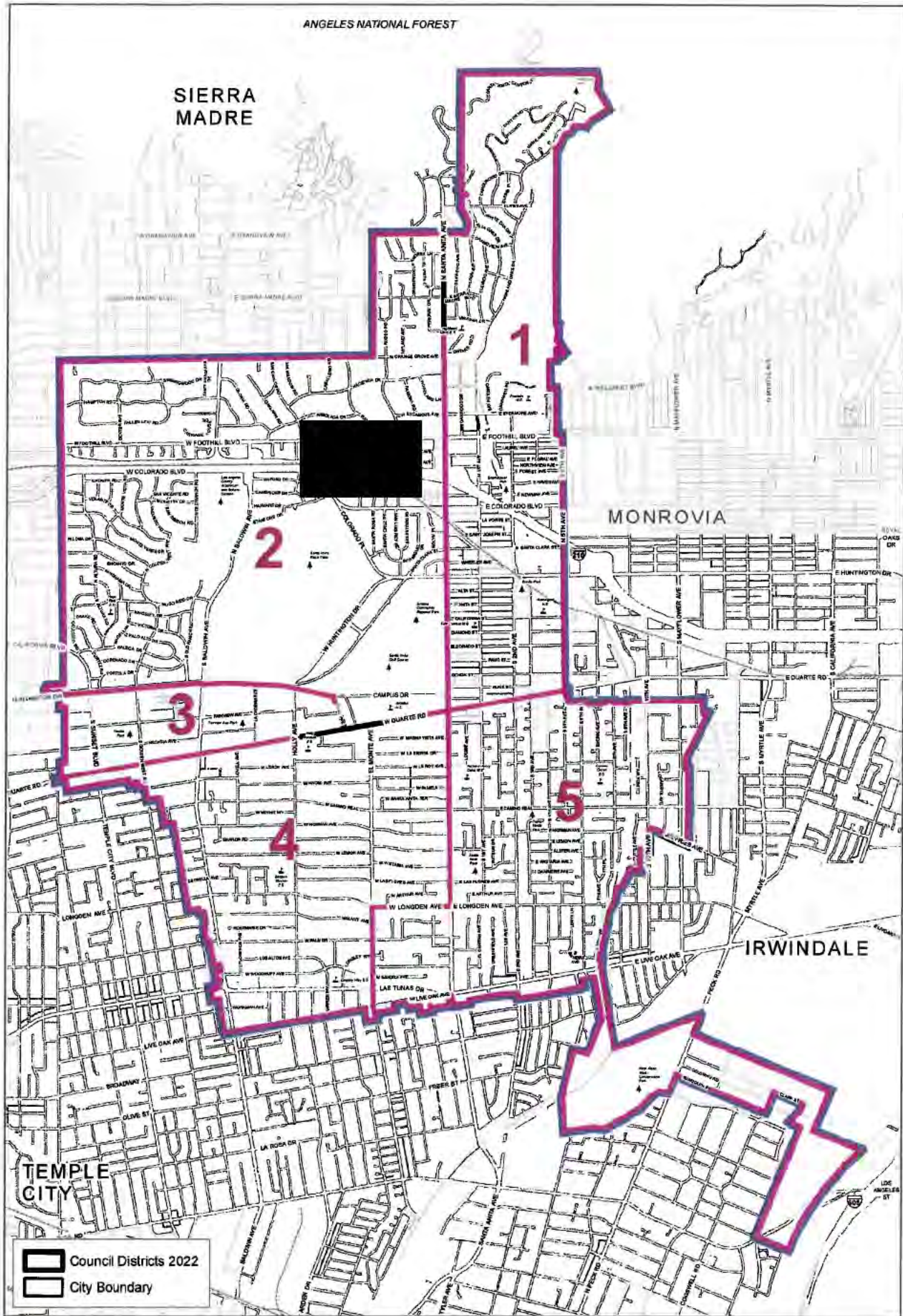

SIERRA MADRE



TEMPLE CITY

MONROVIA

IRWINDALE

 Council Districts 2022  
 City Boundary

**Council District**  
 City of Arcadia, California

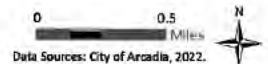

Data Sources: City of Arcadia, 2022.



# City of Arcadia Board/Commission Application

RECEIVED  
CITY OF ARCADIA  
APR 13 2026  
CITY MANAGER

PLEASE PLACE A CHECK MARK NEXT TO THE BOARD OR COMMISSION FOR WHICH YOU WOULD LIKE TO APPLY (more than one selection may be made):

- Arcadia Beautiful Commission\*
- Arcadia Museum Commission
- Human Resources Commission
- Library Board of Trustees
- Planning Commission
- Recreation and Parks Commission
- Senior Citizens Commission
- Arcadia Health Commission

NAME Lois Merritt DATE OF BIRTH (mm/dd/yyyy) [REDACTED]

RESIDENTIAL ADDRESS [REDACTED] Arcadia CA 91007  
(Note: Cannot be a mailing address or PO Box)

BUSINESS ADDRESS (HEALTH COMMISSION ONLY) \_\_\_\_\_

I CERTIFY THAT I AM A RESIDENT OF DISTRICT  ONE  TWO  THREE  FOUR  FIVE *the one that includes "The Gardens"*  
 N/A (Health Commission Only)

PHONE NUMBER [REDACTED] EMAIL ADDRESS [REDACTED]

OCCUPATION retired teacher EMPLOYER \_\_\_\_\_

ARE YOU AN ARCADIA REGISTERED VOTER?  YES  NO

HOW LONG HAVE YOU BEEN A RESIDENT? (If Applicable) Since Dec. 1976

PLEASE ANSWER THE QUESTIONS BELOW. YOU MAY USE ADDITIONAL SHEETS OF PAPER AS NECESSARY.

EDUCATION (Include professional or vocational licenses or certificates)  
credentialed teacher for grades K-8, ESL certificated teacher *s.s. tchr at church. Brownies. Cub Scouts. soccer, etc.*

COMMUNITY INVOLVEMENT (List organization memberships and committee assignments)  
I organized a petition for my community of 300 homes to ask Arcadia to build a sidewalk so that we can safely walk to the A line, the post office, and various businesses. Arcadia did honor our request.

PLEASE DESCRIBE ANY BACKGROUND, TRAINING, OR INTERESTS THAT QUALIFY YOU AS AN APPOINTEE  
Many years of service in the public schools. I grew up in Ethiopia, myself, and I have a heart for outsiders--those who come to America. I have helped two refugee families with ESL, academics, and adjustment. I especially

WHAT INTERESTS YOU ABOUT THE BOARD/COMMISSION YOU ARE APPLYING FOR?  
I am a lifelong lover of books *like to help parents to help their kids.*

ARE YOU AWARE OF THE TIME COMMITMENT NECESSARY TO FULFILL THE OBLIGATIONS OF AN APPOINTMENT TO THIS POSITION?

YES  NO

NOTE: FOR LIBRARY BOARD OF TRUSTEE AND PLANNING COMMISSION APPLICATIONS ONLY

STATE LAW AND THE CITY CONFLICT OF INTEREST CODE REQUIRES THAT LIBRARY BOARD OF TRUSTEE MEMBERS AND PLANNING COMMISSIONERS FILE A STATEMENT OF ECONOMIC INTERESTS (FORM 700) ANNUALLY AS WELL AS RELATED FORMS WHEN ASSUMING AND LEAVING OFFICE (e.g. sources of income, loans, gifts, investments, interest in real property as required by state law). DO YOU AGREE TO FILE ALL REQUIRED FORMS IN A TIMELY MANNER AS REQUIRED BY THE CITY'S FILING OFFICIAL?

YES  NO

---

**\*ARCADIA BEAUTIFUL APPLICANTS ONLY**

ARE YOU AWARE THAT THE PRIMARY FUNCTION OF THE ARCADIA BEAUTIFUL COMMISSION IS TO ACT AS JUDGES FOR THE COMMISSIONS AWARD PROGRAMS (Spring Home, Holiday Decoration, and Water Smart Hero awards)?

YES  NO

DO YOU HAVE THE ABILITY TO TRAVEL BY CAR DURING THE DAY AND IN THE EVENING FOR THE PURPOSE OF JUDGING?

YES  NO

THE ARCADIA BEAUTIFUL COMMISSION USUALLY HAS FOUR REGULAR MEETINGS EACH YEAR WITH ADDITIONAL MEETINGS AND/OR TIME COMMITMENTS SCHEDULED FOR THE PURPOSE OF CONDUCTING JUDGING FOR THE AWARD PROGRAMS, PARTICIPATING IN A 3-4 HOUR HOLIDAY DECORATION AWARD RECOGNITION EVENT, AND PARTICIPATING IN ARBOR DAY PROGRAMS. ADDITIONALLY, PRELIMINARY JUDGING FOR THE SPRING HOME AND HOLIDAY DECORATION AWARDS IS DONE WITH EACH COMMISSIONER TAKING RESPONSIBILITY FOR A SECTION OF THE CITY AND DRIVING THROUGH THE NEIGHBORHOODS TO SELECT THEIR NOMINATIONS FOR FINAL JUDGING BY THE COMMISSION. ARE YOU ABLE TO FULFILL THIS TIME COMMITMENT?

YES  NO

---

I HEREBY CERTIFY THAT THE FOREGOING INFORMATION IS TRUE AND CORRECT TO THE BEST OF MY KNOWLEDGE.



SIGNATURE

*Arcadia 8, 2026*

DATE

NOTE: The City of Arcadia reserves the right to use the information provided on this application to verify your residential address and voter registration status. The information provided on this application is for internal use only and confidential information will not be released to the public.

PLEASE SUBMIT YOUR COMPLETED APPLICATION TO: CITY CLERK'S OFFICE  
240 W. HUNTINGTON DRIVE  
ARCADIA, CA 91007

OR

Email us at [CityClerk@ArcadiaCA.gov](mailto:CityClerk@ArcadiaCA.gov)

Questions? Please contact us at (626) 574-5455

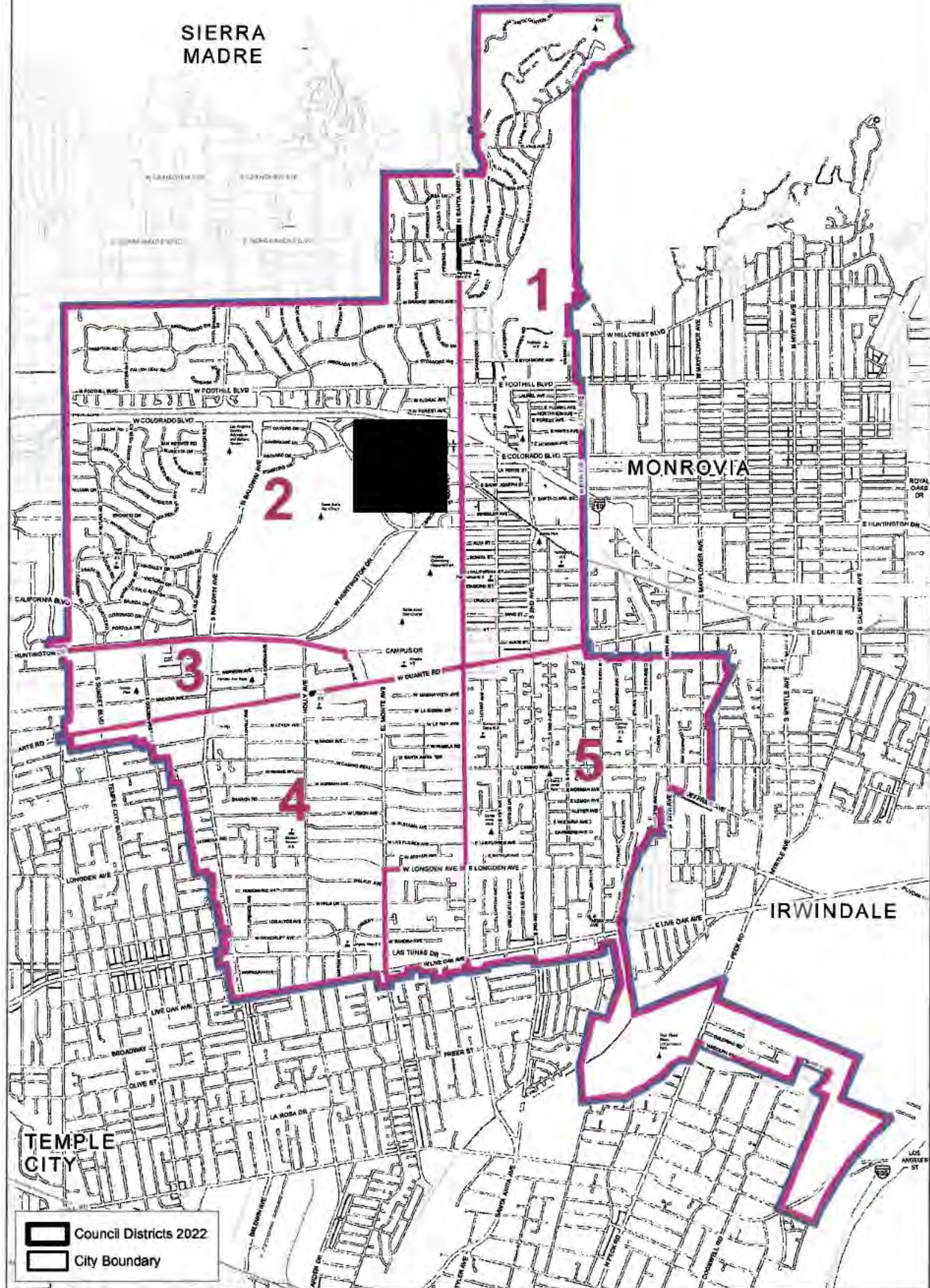

SIERRA MADRE



TEMPLE CITY

MONROVIA

IRWINDALE

 Council Districts 2022  
 City Boundary



**Council District**  
 City of Arcadia, California



# City of Arcadia Board/Commission Application

RECEIVED  
CITY OF ARCADIA  
APR 20 2026  
CITY MANAGER

PLEASE PLACE A CHECK MARK NEXT TO THE BOARD OR COMMISSION FOR WHICH YOU WOULD LIKE TO APPLY (more than one selection may be made):

- Arcadia Beautiful Commission\*
- Arcadia Museum Commission
- Human Resources Commission
- Library Board of Trustees
- Planning Commission
- Recreation and Parks Commission
- Senior Citizens Commission
- Arcadia Health Commission

NAME Elizabeth Renfrew DATE OF BIRTH (mm/dd/yyyy) [REDACTED]  
FIRST LAST

RESIDENTIAL ADDRESS [REDACTED] Arcadia 91007  
(Note: Cannot be a mailing address or PO Box)

BUSINESS ADDRESS (HEALTH COMMISSION ONLY) \_\_\_\_\_

I CERTIFY THAT I AM A RESIDENT OF DISTRICT  ONE  TWO  THREE  FOUR  FIVE  
 N/A (Health Commission Only)

PHONE NUMBER [REDACTED] EMAIL ADDRESS [REDACTED]

OCCUPATION Retired EMPLOYER \_\_\_\_\_

ARE YOU AN ARCADIA REGISTERED VOTER?  YES  NO

HOW LONG HAVE YOU BEEN A RESIDENT? (If Applicable) 38 years

PLEASE ANSWER THE QUESTIONS BELOW. YOU MAY USE ADDITIONAL SHEETS OF PAPER AS NECESSARY.

EDUCATION (Include professional or vocational licenses or certificates)

BS in Nutrition

COMMUNITY INVOLVEMENT (List organization memberships and committee assignments)

Volunteer at Library, am a member of The Friends of the Library.

Volunteer at Holy Angels Church

PLEASE DESCRIBE ANY BACKGROUND, TRAINING, OR INTERESTS THAT QUALIFY YOU AS AN APPOINTEE

Love the library and what it offers to our community. I volunteer there many hours and want to be apart of making it better.

WHAT INTERESTS YOU ABOUT THE BOARD/COMMISSION YOU ARE APPLYING FOR?

The library should be a welcoming site for all the community. Always want to learn more and how I can help it fill its goal.

ARE YOU AWARE OF THE TIME COMMITMENT NECESSARY TO FULFILL THE OBLIGATIONS OF AN APPOINTMENT TO THIS POSITION?

YES  NO

NOTE: FOR LIBRARY BOARD OF TRUSTEE AND PLANNING COMMISSION APPLICATIONS ONLY  
STATE LAW AND THE CITY CONFLICT OF INTEREST CODE REQUIRES THAT LIBRARY BOARD OF TRUSTEE MEMBERS AND PLANNING COMMISSIONERS FILE A STATEMENT OF ECONOMIC INTERESTS (FORM 700) ANNUALLY AS WELL AS RELATED FORMS WHEN ASSUMING AND LEAVING OFFICE (e.g. sources of income, loans, gifts, investments, interest in real property as required by state law). DO YOU AGREE TO FILE ALL REQUIRED FORMS IN A TIMELY MANNER AS REQUIRED BY THE CITY'S FILING OFFICIAL?

YES  NO

---

**\*ARCADIA BEAUTIFUL APPLICANTS ONLY**

ARE YOU AWARE THAT THE PRIMARY FUNCTION OF THE ARCADIA BEAUTIFUL COMMISSION IS TO ACT AS JUDGES FOR THE COMMISSIONS AWARD PROGRAMS (Spring Home, Holiday Decoration, and Water Smart Hero awards)?

YES  NO

DO YOU HAVE THE ABILITY TO TRAVEL BY CAR DURING THE DAY AND IN THE EVENING FOR THE PURPOSE OF JUDGING?

YES  NO

THE ARCADIA BEAUTIFUL COMMISSION USUALLY HAS FOUR REGULAR MEETINGS EACH YEAR WITH ADDITIONAL MEETINGS AND/OR TIME COMMITMENTS SCHEDULED FOR THE PURPOSE OF CONDUCTING JUDGING FOR THE AWARD PROGRAMS, PARTICIPATING IN A 3-4 HOUR HOLIDAY DECORATION AWARD RECOGNITION EVENT, AND PARTICIPATING IN ARBOR DAY PROGRAMS. ADDITIONALLY, PRELIMINARY JUDGING FOR THE SPRING HOME AND HOLIDAY DECORATION AWARDS IS DONE WITH EACH COMMISSIONER TAKING RESPONSIBILITY FOR A SECTION OF THE CITY AND DRIVING THROUGH THE NEIGHBORHOODS TO SELECT THEIR NOMINATIONS FOR FINAL JUDGING BY THE COMMISSION. ARE YOU ABLE TO FULFILL THIS TIME COMMITMENT?

YES  NO

---

I HEREBY CERTIFY THAT THE FOREGOING INFORMATION IS TRUE AND CORRECT TO THE BEST OF MY KNOWLEDGE.

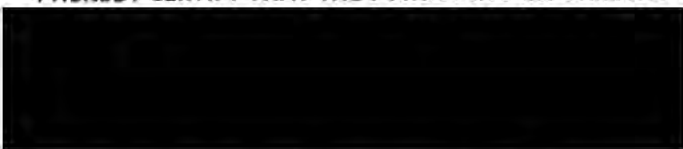

April 17, 2026

DATE

NOTE: The City of Arcadia reserves the right to use the information provided on this application to verify your residential address and voter registration status. The information provided on this application is for internal use only and confidential information will not be released to the public.

PLEASE SUBMIT YOUR COMPLETED APPLICATION TO: CITY CLERK'S OFFICE  
240 W. HUNTINGTON DRIVE  
ARCADIA, CA 91007

OR

Email us at [CityClerk@ArcadiaCA.gov](mailto:CityClerk@ArcadiaCA.gov)

Questions? Please contact us at (626) 574-5455

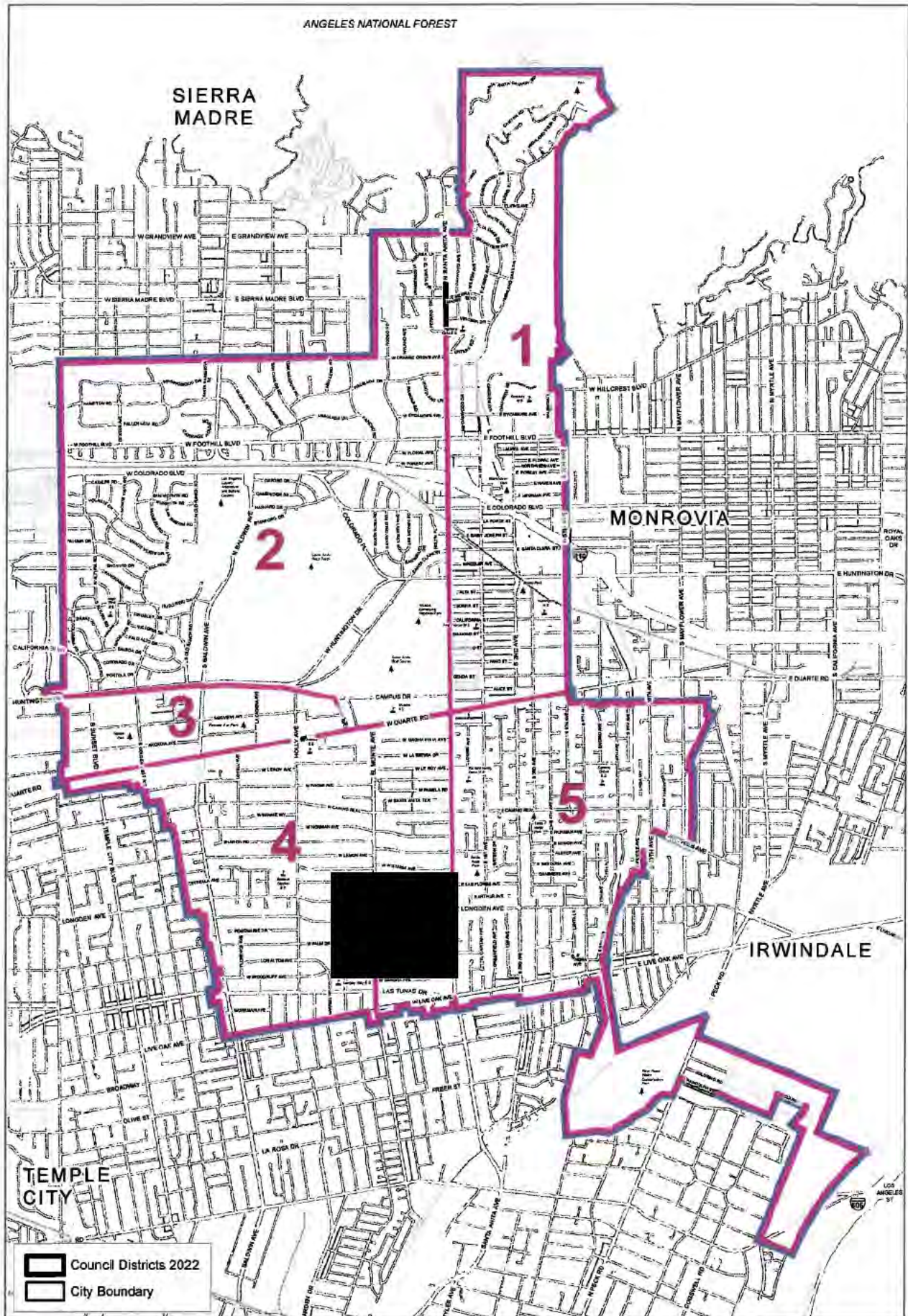

**Council District**  
City of Arcadia, California



# City of Arcadia Board/Commission Application

RECEIVED

APR 29 2026

PLEASE PLACE A CHECK MARK NEXT TO THE BOARD OR COMMISSION FOR WHICH YOU WOULD LIKE TO APPLY (more than one selection may be made):

- Arcadia Beautiful Commission\*
- Arcadia Museum Commission
- Human Resources Commission
- Library Board of Trustees
- Planning Commission
- Recreation and Parks Commission
- Senior Citizens Commission
- Arcadia Health Commission

NAME Jeff Chang DATE OF BIRTH (mm/dd/yyyy) [REDACTED]

FIRST LAST RESIDENTIAL ADDRESS [REDACTED] Arcadia CA 91006

(Note: Cannot be a mailing address or PO Box)

BUSINESS ADDRESS (HEALTH COMMISSION ONLY) \_\_\_\_\_

I CERTIFY THAT I AM A RESIDENT OF DISTRICT  ONE  TWO  THREE  FOUR  FIVE  
 N/A (Health Commission Only)

PHONE NUMBER [REDACTED] EMAIL ADDRESS [REDACTED]

OCCUPATION Insurance Broker EMPLOYER National Life Group

ARE YOU AN ARCADIA REGISTERED VOTER?  YES  NO

HOW LONG HAVE YOU BEEN A RESIDENT? (If Applicable) 19 years

PLEASE ANSWER THE QUESTIONS BELOW. YOU MAY USE ADDITIONAL SHEETS OF PAPER AS NECESSARY.

### EDUCATION (Include professional or vocational licenses or certificates)

Cal State Fullerton, College of Business and Economics, B.A.; Microsoft Certified Professional; Accident, Health, Life, Sickness Insurance License in 22 states; Certified Insurance Field Trainer; Certified 403(b)/457 Provider.

### COMMUNITY INVOLVEMENT (List organization memberships and committee assignments)

Arcadia Chinese Association(Secretary), Arcadia Safety Guardians(President), Arcadia High School Chinese Parent Booster Club(Director), Foothills Middle School Chinese Parent Booster Club(Vice President).

### PLEASE DESCRIBE ANY BACKGROUND, TRAINING, OR INTERESTS THAT QUALIFY YOU AS AN APPOINTEE

I have a diverse background in management, overseeing teams across various industries and companies with focus on refining processes to enhance the end-user experience. I was the owner and operator of 3 retail shops which provided me with understanding of consumer behavior and ability to make adjustments based on feedback, one of the shop was in Arcadia from 2012 to 2020.

### WHAT INTERESTS YOU ABOUT THE BOARD/COMMISSION YOU ARE APPLYING FOR?

As a long time resident and a frequent visitor, I'm applying for the Library Board of Trustees to give back to an institution that has been an important part of my family's life for over a decade. I've been taking my children to the Arcadia Library since they were young, now that my eldest is a freshman at AHS and she goes to the library almost everyday for her studies, I would like volunteer my time and contribute my professional experience to give back to the cornerstone of our community.

ARE YOU AWARE OF THE TIME COMMITMENT NECESSARY TO FULFILL THE OBLIGATIONS OF AN APPOINTMENT TO THIS POSITION?

YES  NO

NOTE: FOR LIBRARY BOARD OF TRUSTEE AND PLANNING COMMISSION APPLICATIONS ONLY  
STATE LAW AND THE CITY CONFLICT OF INTEREST CODE REQUIRES THAT LIBRARY BOARD OF TRUSTEE MEMBERS AND PLANNING COMMISSIONERS FILE A STATEMENT OF ECONOMIC INTERESTS (FORM 700) ANNUALLY AS WELL AS RELATED FORMS WHEN ASSUMING AND LEAVING OFFICE (e.g. sources of income, loans, gifts, investments, interest in real property as required by state law). DO YOU AGREE TO FILE ALL REQUIRED FORMS IN A TIMELY MANNER AS REQUIRED BY THE CITY'S FILING OFFICIAL?

YES  NO

---

**\*ARCADIA BEAUTIFUL APPLICANTS ONLY**

ARE YOU AWARE THAT THE PRIMARY FUNCTION OF THE ARCADIA BEAUTIFUL COMMISSION IS TO ACT AS JUDGES FOR THE COMMISSIONS AWARD PROGRAMS (Spring Home, Holiday Decoration, and Water Smart Hero awards)?

YES  NO

DO YOU HAVE THE ABILITY TO TRAVEL BY CAR DURING THE DAY AND IN THE EVENING FOR THE PURPOSE OF JUDGING?

YES  NO

THE ARCADIA BEAUTIFUL COMMISSION USUALLY HAS FOUR REGULAR MEETINGS EACH YEAR WITH ADDITIONAL MEETINGS AND/OR TIME COMMITMENTS SCHEDULED FOR THE PURPOSE OF CONDUCTING JUDGING FOR THE AWARD PROGRAMS, PARTICIPATING IN A 3-4 HOUR HOLIDAY DECORATION AWARD RECOGNITION EVENT, AND PARTICIPATING IN ARBOR DAY PROGRAMS. ADDITIONALLY, PRELIMINARY JUDGING FOR THE SPRING HOME AND HOLIDAY DECORATION AWARDS IS DONE WITH EACH COMMISSIONER TAKING RESPONSIBILITY FOR A SECTION OF THE CITY AND DRIVING THROUGH THE NEIGHBORHOODS TO SELECT THEIR NOMINATIONS FOR FINAL JUDGING BY THE COMMISSION. ARE YOU ABLE TO FULFILL THIS TIME COMMITMENT?

YES  NO

---

I HEREBY CERTIFY THAT THE FOREGOING INFORMATION IS TRUE AND CORRECT TO THE BEST OF MY KNOWLEDGE.



April 29, 2026

DATE

NOTE: The City of Arcadia reserves the right to use the information provided on this application to verify your residential address and voter registration status. The information provided on this application is for internal use only and confidential information will not be released to the public.

PLEASE SUBMIT YOUR COMPLETED APPLICATION TO: CITY CLERK'S OFFICE  
240 W. HUNTINGTON DRIVE  
ARCADIA, CA 91007

OR

Email us at [CityClerk@ArcadiaCA.gov](mailto:CityClerk@ArcadiaCA.gov)

Questions? Please contact us at (626) 574-5455

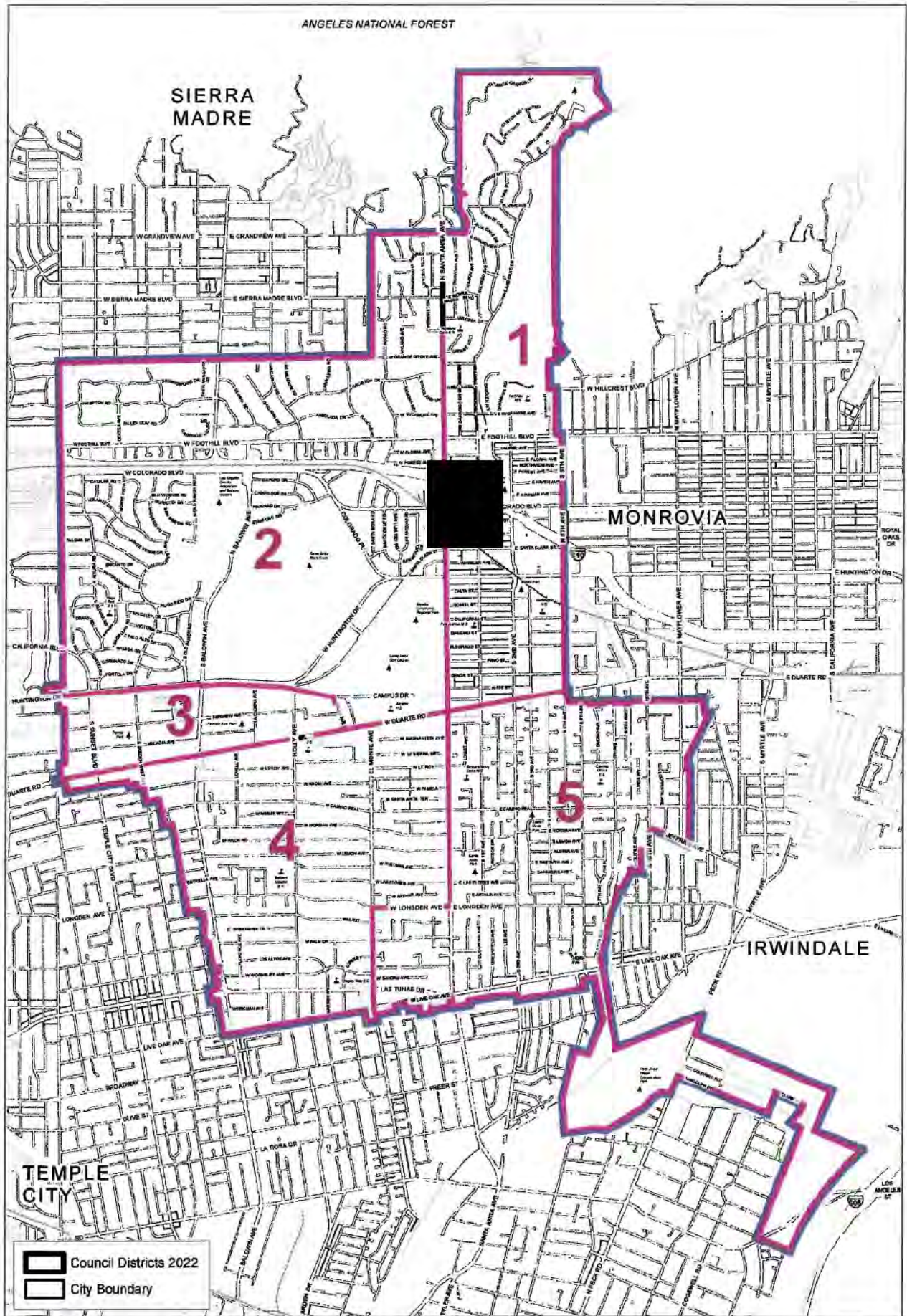

**Council District**  
**City of Arcadia, California**



# City of Arcadia Board/Commission Application

RECEIVED

MAY 19 2026

PLEASE PLACE A CHECK MARK NEXT TO THE BOARD OR COMMISSION FOR WHICH YOU WOULD LIKE TO APPLY (more than one selection may be made):

CITY OF ARCADIA  
CITY CLERK

- |   |  |
|---|--|
| <input type="checkbox"/> Arcadia Beautiful Commission*        | <input type="checkbox"/> Planning Commission             |
| <input type="checkbox"/> Arcadia Museum Commission            | <input type="checkbox"/> Recreation and Parks Commission |
| <input type="checkbox"/> Human Resources Commission           | <input type="checkbox"/> Senior Citizens Commission      |
| <input checked="" type="checkbox"/> Library Board of Trustees | <input type="checkbox"/> Arcadia Health Commission       |

NAME Sara Noji DATE OF BIRTH (mm/dd/yyyy) [REDACTED]

FIRST LAST

RESIDENTIAL ADDRESS [REDACTED] Arcadia, CA 91006

(Note: Cannot be a mailing address or PO Box)

BUSINESS ADDRESS (HEALTH COMMISSION ONLY) \_\_\_\_\_

I CERTIFY THAT I AM A RESIDENT OF DISTRICT  ONE  TWO  THREE  FOUR  FIVE  
 N/A (Health Commission Only)

PHONE NUMBER [REDACTED] EMAIL ADDRESS [REDACTED]

OCCUPATION Project Manager EMPLOYER Los Angeles Education Partnership (LAEP)

ARE YOU AN ARCADIA REGISTERED VOTER?  YES  NO

HOW LONG HAVE YOU BEEN A RESIDENT? (if Applicable) 25+ years

PLEASE ANSWER THE QUESTIONS BELOW. YOU MAY USE ADDITIONAL SHEETS OF PAPER AS NECESSARY.

### EDUCATION (Include professional or vocational licenses or certificates)

Bachelor of the Arts, Integrated Educational Studies. Community & minor in Dance, Chapman University 2016  
Project Management Certificate, UCLA Extension, 2023

### COMMUNITY INVOLVEMENT (List organization memberships and committee assignments)

CORO Lead LA Cohort 8, Sept 2025-May 2026  
Florence Firestone Walnut Park Partnership, Aug 2016-July 2018  
Work experience- 10 years at community based organization for education

### PLEASE DESCRIBE ANY BACKGROUND, TRAINING, OR INTERESTS THAT QUALIFY YOU AS AN APPOINTEE

For the past 6 years, I have been the board liaison at the mid-sized nonprofit. I have a very indepth knowledge of how the board should advise on the mission and vision of any organization serving the community such as the library serving Arcadia residents. This work experience also gives me direct experience working with community members and helping them advocate for their needs.

### WHAT INTERESTS YOU ABOUT THE BOARD/COMMISSION YOU ARE APPLYING FOR?

I am a life long library and book lover, and have recently started using the library services more and more. I want to continue to advertise what an important community resource it is. I am a good representative of the community not only for my own needs, but cross-generationally with Arcadia friends and family, from my older relatives to my friends with children. I'd like to serve my own local community as an advisor to the already great staff at Arcadia Library.

ARE YOU AWARE OF THE TIME COMMITMENT NECESSARY TO FULFILL THE OBLIGATIONS OF AN APPOINTMENT TO THIS POSITION?

YES  NO

**NOTE: FOR LIBRARY BOARD OF TRUSTEE AND PLANNING COMMISSION APPLICATIONS ONLY**

STATE LAW AND THE CITY CONFLICT OF INTEREST CODE REQUIRES THAT LIBRARY BOARD OF TRUSTEE MEMBERS AND PLANNING COMMISSIONERS FILE A STATEMENT OF ECONOMIC INTERESTS (FORM 700) ANNUALLY AS WELL AS RELATED FORMS WHEN ASSUMING AND LEAVING OFFICE (e.g. sources of income, loans, gifts, investments, interest in real property as required by state law). DO YOU AGREE TO FILE ALL REQUIRED FORMS IN A TIMELY MANNER AS REQUIRED BY THE CITY'S FILING OFFICIAL?

YES  NO

---

**\*ARCADIA BEAUTIFUL APPLICANTS ONLY**

ARE YOU AWARE THAT THE PRIMARY FUNCTION OF THE ARCADIA BEAUTIFUL COMMISSION IS TO ACT AS JUDGES FOR THE COMMISSIONS AWARD PROGRAMS (Spring Home, Holiday Decoration, and Water Smart Hero awards)?

YES  NO

DO YOU HAVE THE ABILITY TO TRAVEL BY CAR DURING THE DAY AND IN THE EVENING FOR THE PURPOSE OF JUDGING?

YES  NO

THE ARCADIA BEAUTIFUL COMMISSION USUALLY HAS FOUR REGULAR MEETINGS EACH YEAR WITH ADDITIONAL MEETINGS AND/OR TIME COMMITMENTS SCHEDULED FOR THE PURPOSE OF CONDUCTING JUDGING FOR THE AWARD PROGRAMS, PARTICIPATING IN A 3-4 HOUR HOLIDAY DECORATION AWARD RECOGNITION EVENT, AND PARTICIPATING IN ARBOR DAY PROGRAMS. ADDITIONALLY, PRELIMINARY JUDGING FOR THE SPRING HOME AND HOLIDAY DECORATION AWARDS IS DONE WITH EACH COMMISSIONER TAKING RESPONSIBILITY FOR A SECTION OF THE CITY AND DRIVING THROUGH THE NEIGHBORHOODS TO SELECT THEIR NOMINATIONS FOR FINAL JUDGING BY THE COMMISSION. ARE YOU ABLE TO FULFILL THIS TIME COMMITMENT?

YES  NO

---

I HEREBY CERTIFY THAT THE FOREGOING INFORMATION IS TRUE AND CORRECT TO THE BEST OF MY KNOWLEDGE.

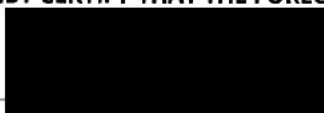

SIGNATURE

5/12/26

DATE

**NOTE: The City of Arcadia reserves the right to use the information provided on this application to verify your residential address and voter registration status. The information provided on this application is for internal use only and confidential information will not be released to the public.**

PLEASE SUBMIT YOUR COMPLETED APPLICATION TO: CITY CLERK'S OFFICE  
240 W. HUNTINGTON DRIVE  
ARCADIA, CA 91007

OR

Email us at [CityClerk@ArcadiaCA.gov](mailto:CityClerk@ArcadiaCA.gov)

Questions? Please contact us at (626) 574-5455

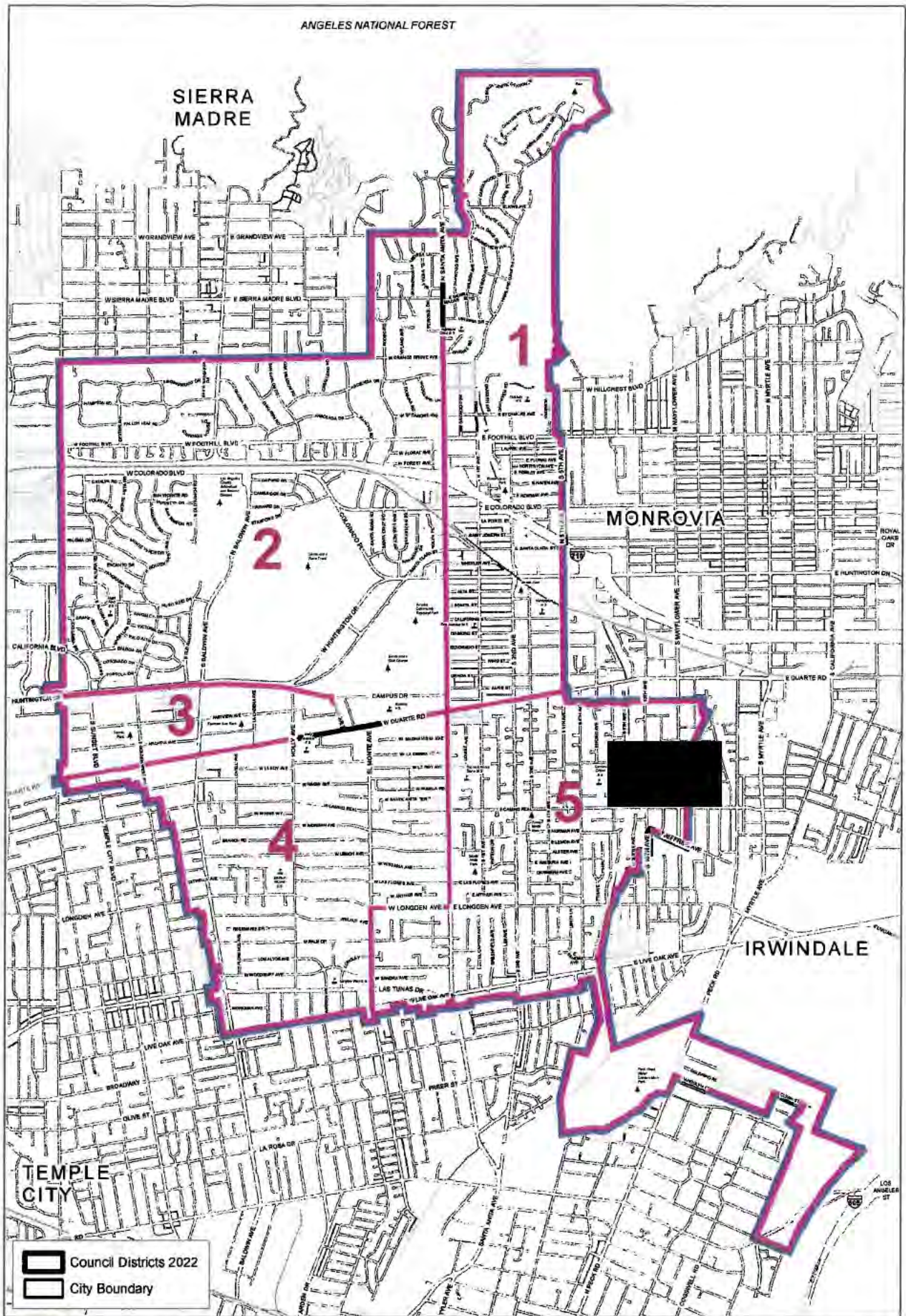

**Council District**  
*City of Arcadia, California*



RECEIVED  
CITY OF ARC  
MAY 21 2026

# City of Arcadia Board/Commission Application

RECEIVED  
CITY OF ARC  
MAY 21 2026

PLEASE PLACE A CHECK MARK NEXT TO THE BOARD OR COMMISSION FOR WHICH YOU WOULD LIKE TO APPLY (more than one selection may be made):

- |   |  |
|---|--|
| <input type="checkbox"/> Arcadia Beautiful Commission*        | <input type="checkbox"/> Planning Commission             |
| <input type="checkbox"/> Arcadia Museum Commission            | <input type="checkbox"/> Recreation and Parks Commission |
| <input type="checkbox"/> Human Resources Commission           | <input type="checkbox"/> Senior Citizens Commission      |
| <input checked="" type="checkbox"/> Library Board of Trustees | <input type="checkbox"/> Arcadia Health Commission       |

NAME Roberta Marquez DATE OF BIRTH (mm/dd/yyyy) [REDACTED]

FIRST LAST

RESIDENTIAL ADDRESS [REDACTED] Arcadia, CA 91006

(Note: Cannot be a mailing address or PO Box)

BUSINESS ADDRESS (HEALTH COMMISSION ONLY) \_\_\_\_\_

I CERTIFY THAT I AM A RESIDENT OF DISTRICT  ONE  TWO  THREE  FOUR  FIVE  
 N/A (Health Commission Only)

PHONE NUMBER [REDACTED] EMAIL ADDRESS [REDACTED]

OCCUPATION Retired Librarian EMPLOYER former employer: Los Angeles County Library

ARE YOU AN ARCADIA REGISTERED VOTER?  YES  NO

HOW LONG HAVE YOU BEEN A RESIDENT? (If Applicable) 41 years

PLEASE ANSWER THE QUESTIONS BELOW. YOU MAY USE ADDITIONAL SHEETS OF PAPER AS NECESSARY.

### EDUCATION (Include professional or vocational licenses or certificates)

B.A. English Literature - Calif. State University Fullerton, 1979  
M.L.S. Library & Information Science, USC, 1984

### COMMUNITY INVOLVEMENT (List organization memberships and committee assignments)

Volunteering at the L.A. County Arboretum Library (1 1/2 years); Volunteering for the Arcadia Public Library English Conversation Class (8 months); Arcadia Friends of the Library, member and volunteer at FOL Bookstore; Arcadia Historical Society, member

### PLEASE DESCRIBE ANY BACKGROUND, TRAINING, OR INTERESTS THAT QUALIFY YOU AS AN APPOINTEE

I have been a librarian with L.A. County Library for 40 years, retiring in fall of 2024. During that time I have been a library manager (25 years), as well as a reference librarian, and a children's librarian, so I really know the work involved in running a library. Prior to that, I worked at the California State University Fullerton Library part-time for nearly three years, and I have been a library user my entire life.

### WHAT INTERESTS YOU ABOUT THE BOARD/COMMISSION YOU ARE APPLYING FOR?

I love libraries; I live and breathe libraries! I believe that the Arcadia Public Library is one of the best libraries in the San Gabriel Valley. It has s-o much community support and a wonderful Friends of the Library group. It is extremely well patronized by all age groups: children, teens, and adults. I have attended many programs at Arcadia Public Library, for adults and children — and I know the value these programs add to the community. I would like to be a part of shaping the future of Arcadia Public Library, and the best way I see to do this is by joining the Library Board of Trustees.

ARE YOU AWARE OF THE TIME COMMITMENT NECESSARY TO FULFILL THE OBLIGATIONS OF AN APPOINTMENT TO THIS POSITION?

YES  NO

NOTE: FOR LIBRARY BOARD OF TRUSTEE AND PLANNING COMMISSION APPLICATIONS ONLY

STATE LAW AND THE CITY CONFLICT OF INTEREST CODE REQUIRES THAT LIBRARY BOARD OF TRUSTEE MEMBERS AND PLANNING COMMISSIONERS FILE A STATEMENT OF ECONOMIC INTERESTS (FORM 700) ANNUALLY AS WELL AS RELATED FORMS WHEN ASSUMING AND LEAVING OFFICE (e.g. sources of income, loans, gifts, investments, interest in real property as required by state law). DO YOU AGREE TO FILE ALL REQUIRED FORMS IN A TIMELY MANNER AS REQUIRED BY THE CITY'S FILING OFFICIAL?

YES  NO

---

**\*ARCADIA BEAUTIFUL APPLICANTS ONLY**

ARE YOU AWARE THAT THE PRIMARY FUNCTION OF THE ARCADIA BEAUTIFUL COMMISSION IS TO ACT AS JUDGES FOR THE COMMISSIONS AWARD PROGRAMS (Spring Home, Holiday Decoration, and Water Smart Hero awards)?

YES  NO

DO YOU HAVE THE ABILITY TO TRAVEL BY CAR DURING THE DAY AND IN THE EVENING FOR THE PURPOSE OF JUDGING?

YES  NO

THE ARCADIA BEAUTIFUL COMMISSION USUALLY HAS FOUR REGULAR MEETINGS EACH YEAR WITH ADDITIONAL MEETINGS AND/OR TIME COMMITMENTS SCHEDULED FOR THE PURPOSE OF CONDUCTING JUDGING FOR THE AWARD PROGRAMS, PARTICIPATING IN A 3-4 HOUR HOLIDAY DECORATION AWARD RECOGNITION EVENT, AND PARTICIPATING IN ARBOR DAY PROGRAMS. ADDITIONALLY, PRELIMINARY JUDGING FOR THE SPRING HOME AND HOLIDAY DECORATION AWARDS IS DONE WITH EACH COMMISSIONER TAKING RESPONSIBILITY FOR A SECTION OF THE CITY AND DRIVING THROUGH THE NEIGHBORHOODS TO SELECT THEIR NOMINATIONS FOR FINAL JUDGING BY THE COMMISSION. ARE YOU ABLE TO FULFILL THIS TIME COMMITMENT?

YES  NO

---

I HEREBY CERTIFY THAT THE FOREGOING INFORMATION IS TRUE AND CORRECT TO THE BEST OF MY KNOWLEDGE.



May 20, 2026

DATE

NOTE: The City of Arcadia reserves the right to use the information provided on this application to verify your residential address and voter registration status. The information provided on this application is for internal use only and confidential information will not be released to the public.

PLEASE SUBMIT YOUR COMPLETED APPLICATION TO: CITY CLERK'S OFFICE  
240 W. HUNTINGTON DRIVE  
ARCADIA, CA 91007

OR

Email us at [CityClerk@ArcadiaCA.gov](mailto:CityClerk@ArcadiaCA.gov)

Questions? Please contact us at (626) 574-5455

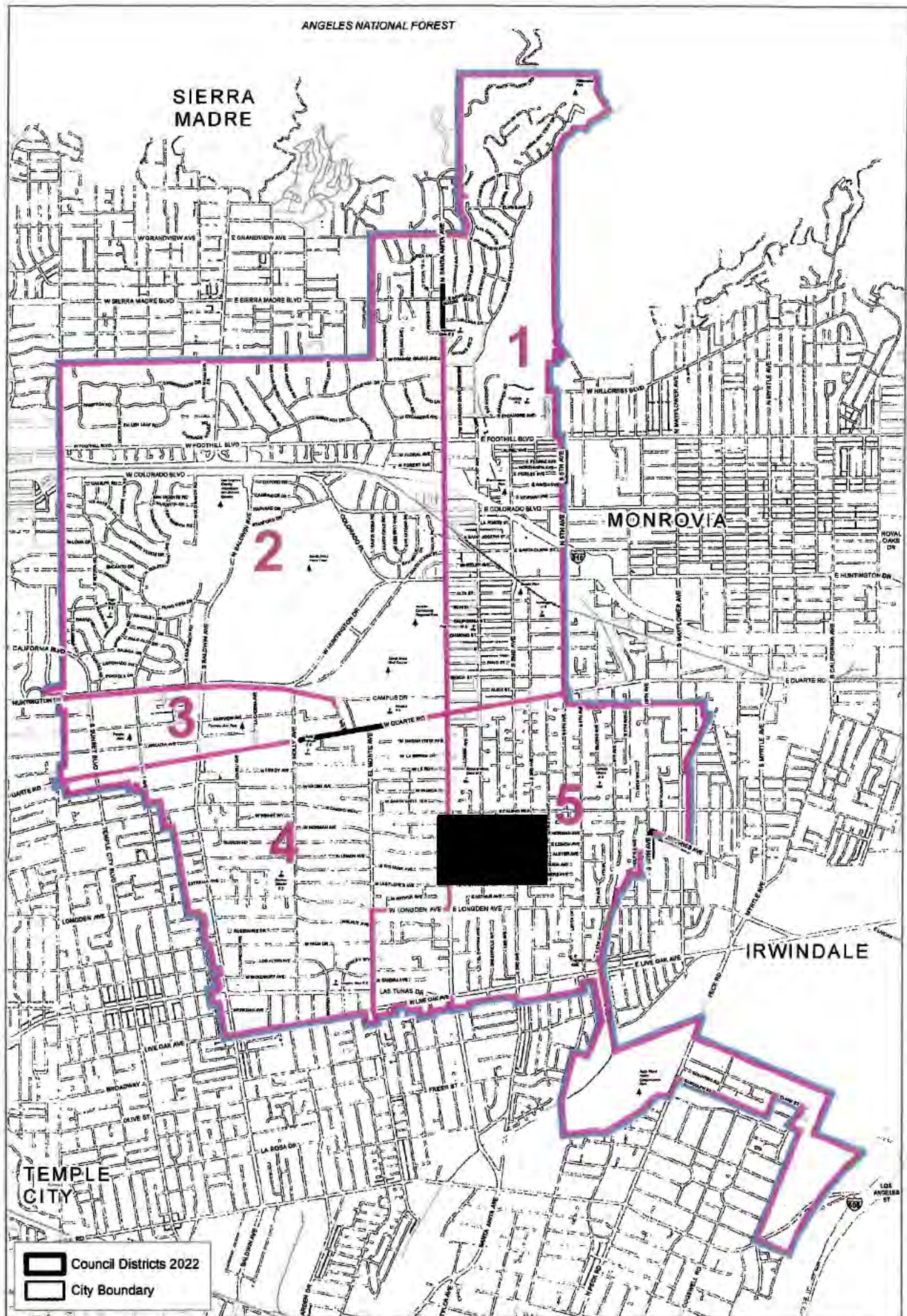

**Council District**  
*City of Arcadia, California*



# City of Arcadia Board/Commission Application

RECEIVED

MAY 22 2026

PLEASE PLACE A CHECK MARK NEXT TO THE BOARD OR COMMISSION FOR WHICH YOU WOULD LIKE TO APPLY (more than one selection may be made):

- Arcadia Beautiful Commission\*
- Arcadia Museum Commission
- Human Resources Commission
- Library Board of Trustees
- Planning Commission
- Recreation and Parks Commission
- Senior Citizens Commission
- Arcadia Health Commission

NAME Bianca Picasso DATE OF BIRTH (mm/dd/yyyy) [REDACTED]

FIRST LAST

RESIDENTIAL ADDRESS [REDACTED] Arcadia Ca 91006

(Note: Cannot be a mailing address or PO Box)

BUSINESS ADDRESS (HEALTH COMMISSION ONLY) \_\_\_\_\_

I CERTIFY THAT I AM A RESIDENT OF DISTRICT  ONE  TWO  THREE  FOUR  FIVE  
 N/A (Health Commission Only)

PHONE NUMBER [REDACTED] EMAIL ADDRESS [REDACTED]

OCCUPATION Technical Support Engineer EMPLOYER VALD Inc.

ARE YOU AN ARCADIA REGISTERED VOTER?  YES  NO

HOW LONG HAVE YOU BEEN A RESIDENT? (If Applicable) 23 years

PLEASE ANSWER THE QUESTIONS BELOW. YOU MAY USE ADDITIONAL SHEETS OF PAPER AS NECESSARY.

**EDUCATION (Include professional or vocational licenses or certificates)**

San Francisco State University  
B.S. Biology: Physiology  
Minor: Chemistry

**COMMUNITY INVOLVEMENT (List organization memberships and committee assignments)**

None at the moment.

**PLEASE DESCRIBE ANY BACKGROUND, TRAINING, OR INTERESTS THAT QUALIFY YOU AS AN APPOINTEE**

Please see additional page in my application folder

**WHAT INTERESTS YOU ABOUT THE BOARD/COMMISSION YOU ARE APPLYING FOR?**

Please see additional page in my application folder

ARE YOU AWARE OF THE TIME COMMITMENT NECESSARY TO FULFILL THE OBLIGATIONS OF AN APPOINTMENT TO THIS POSITION?

YES  NO

NOTE: FOR LIBRARY BOARD OF TRUSTEE AND PLANNING COMMISSION APPLICATIONS ONLY  
STATE LAW AND THE CITY CONFLICT OF INTEREST CODE REQUIRES THAT LIBRARY BOARD OF TRUSTEE MEMBERS AND PLANNING COMMISSIONERS FILE A STATEMENT OF ECONOMIC INTERESTS (FORM 700) ANNUALLY AS WELL AS RELATED FORMS WHEN ASSUMING AND LEAVING OFFICE (e.g. sources of income, loans, gifts, investments, interest in real property as required by state law). DO YOU AGREE TO FILE ALL REQUIRED FORMS IN A TIMELY MANNER AS REQUIRED BY THE CITY'S FILING OFFICIAL?

YES  NO

---

**\*ARCADIA BEAUTIFUL APPLICANTS ONLY**

ARE YOU AWARE THAT THE PRIMARY FUNCTION OF THE ARCADIA BEAUTIFUL COMMISSION IS TO ACT AS JUDGES FOR THE COMMISSIONS AWARD PROGRAMS (Spring Home, Holiday Decoration, and Water Smart Hero awards)?

YES  NO

DO YOU HAVE THE ABILITY TO TRAVEL BY CAR DURING THE DAY AND IN THE EVENING FOR THE PURPOSE OF JUDGING?

YES  NO

THE ARCADIA BEAUTIFUL COMMISSION USUALLY HAS FOUR REGULAR MEETINGS EACH YEAR WITH ADDITIONAL MEETINGS AND/OR TIME COMMITMENTS SCHEDULED FOR THE PURPOSE OF CONDUCTING JUDGING FOR THE AWARD PROGRAMS, PARTICIPATING IN A 3-4 HOUR HOLIDAY DECORATION AWARD RECOGNITION EVENT, AND PARTICIPATING IN ARBOR DAY PROGRAMS. ADDITIONALLY, PRELIMINARY JUDGING FOR THE SPRING HOME AND HOLIDAY DECORATION AWARDS IS DONE WITH EACH COMMISSIONER TAKING RESPONSIBILITY FOR A SECTION OF THE CITY AND DRIVING THROUGH THE NEIGHBORHOODS TO SELECT THEIR NOMINATIONS FOR FINAL JUDGING BY THE COMMISSION. ARE YOU ABLE TO FULFILL THIS TIME COMMITMENT?

YES  NO

---

I HEREBY CERTIFY THAT THE FOREGOING INFORMATION IS TRUE AND CORRECT TO THE BEST OF MY KNOWLEDGE.



SIGNATURE

05/14/2026

DATE

NOTE: The City of Arcadia reserves the right to use the information provided on this application to verify your residential address and voter registration status. The information provided on this application is for internal use only and confidential information will not be released to the public.

PLEASE SUBMIT YOUR COMPLETED APPLICATION TO: CITY CLERK'S OFFICE  
240 W. HUNTINGTON DRIVE  
ARCADIA, CA 91007

OR

Email us at [CityClerk@ArcadiaCA.gov](mailto:CityClerk@ArcadiaCA.gov)

Questions? Please contact us at (626) 574-5455

**PLEASE DESCRIBE ANY BACKGROUND, TRAINING, OR INTERESTS THAT QUALIFY YOU AS AN APPOINTEE**

I am a genuine and active library user. I regularly check out books and DVDs physically or through our library's online system such as Libby. Not to mention, I love to use the recommendation request Band feel accomplish any time my book requests are accepted!

I make a point of encouraging people in my life to take advantage of what the library offers, because I know many residents can benefit from them. That combination of hands-on familiarity with library services and a habit of advocating for them to others reflects exactly the kind of engaged trustee I would be.

**WHAT INTERESTS YOU ABOUT THE BOARD/COMMISSION YOU ARE APPLYING FOR?**

What draws me most to the Library Board of Trustees is the opportunity to help our community discover what the library can truly be.

I was scrolling through social media a few months ago and came across a post about how some libraries let you borrow National Park passes. This was something I had never heard of. I immediately used the library's chat with a librarian feature to find out if our branch carried a pass for a park I was hoping to visit. Although they didn't have that particular one, that conversation opened a door of curiosity in me. I started exploring other resources and programs the library offers that I hadn't known existed, and I was genuinely surprised by what was available.

That experience stayed with me, because it made me wonder how many of our neighbors have no idea what's sitting right there waiting for them. Serving on the Board gives me the chance to ask that question at the community level. I'd love to listen to what residents want and need, and to help ensure the library is actively working to provide it. I want to see it grow into an even more dynamic resource that reflects the needs of our community.

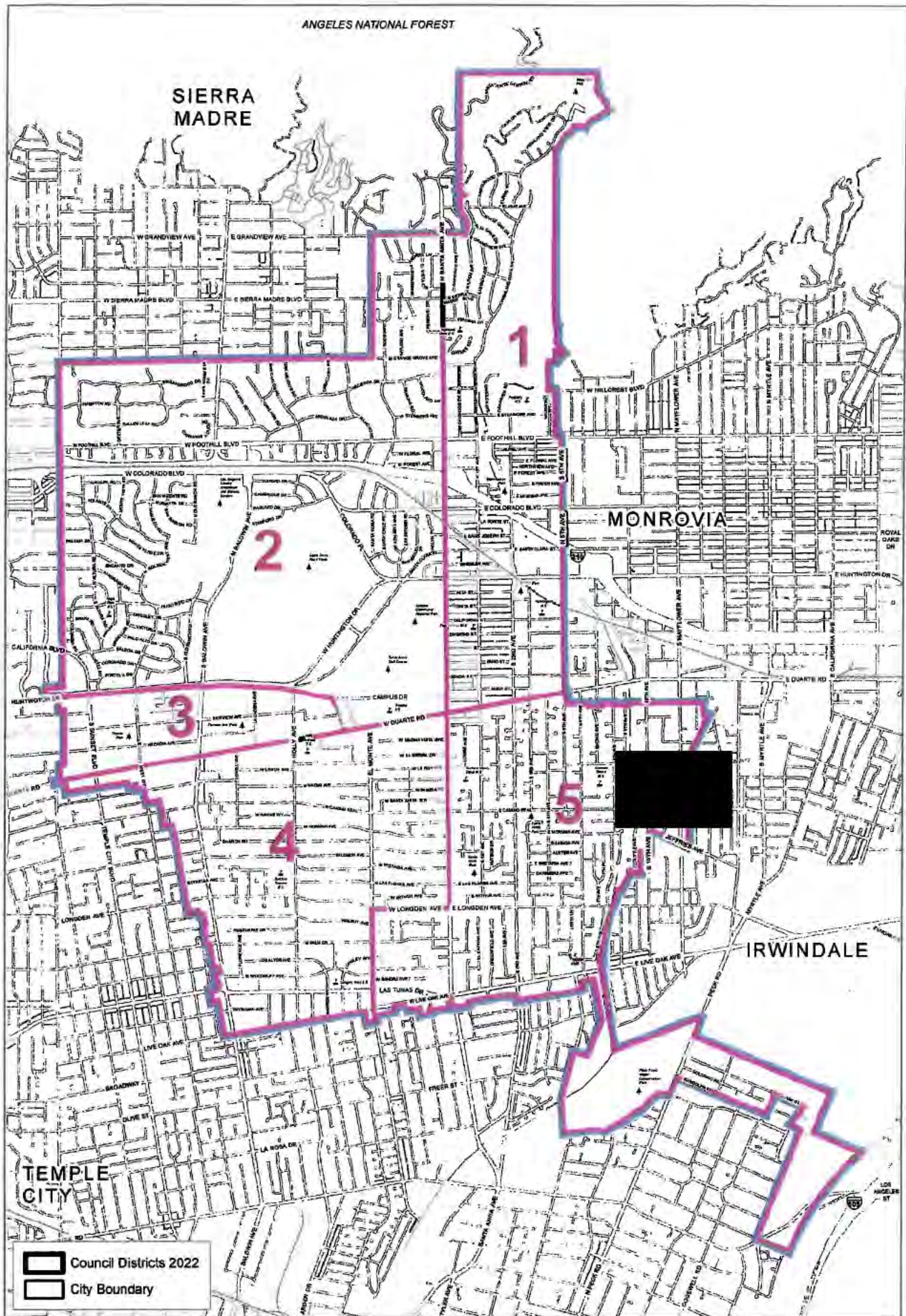

**Council District**  
*City of Arcadia, California*

RECEIVED  
CITY OF ARCADIA  
MAY 22 2026



CITY MANAGER

# Citizen Service Resume

PLEASE PLACE A CHECK MARK NEXT TO THE BOARD/COMMISSION FOR WHICH YOU WOULD LIKE TO APPLY (You may make more than one selection):

- Arcadia Beautiful Commission\*
- Arcadia Museum Commission
- Human Resources Commission
- Library Board of Trustees
- Planning Commission
- Recreation and Parks Commission
- Senior Citizens Commission

\*\*\*\*\*

NAME Carol Saunders DATE OF BIRTH [REDACTED]  
FIRST LAST

RESIDENTIAL ADDRESS [REDACTED] Arcadia CA 91006  
(Note: Cannot be a mailing address or PO Box)

I CERTIFY THAT I AM A RESIDENT OF DISTRICT  ONE  TWO  THREE  FOUR  FIVE  
PHONE NUMBER [REDACTED] EMAIL ADDRESS [REDACTED]

OCCUPATION Retired  
EMPLOYER \_\_\_\_\_ ARE YOU AN ARCADIA REGISTERED VOTER?  YES  NO

HOW LONG HAVE YOU BEEN A RESIDENT? 25 years ARE YOU A LEADERSHIP ACADEMY GRADUATE?  YES  NO

\*\*\*\*\*

PLEASE ANSWER THE QUESTIONS BELOW. YOU MAY USE ADDITIONAL SHEETS OF PAPER AS NECESSARY.

### EDUCATION (include professional or vocational licenses or certificates)

Respiratory Care Practitioner, Registered Respiratory Therapist RCP license retired  
Employed 38 years at City of Hope, last 14 in management.

### COMMUNITY INVOLVEMENT (List organization memberships and committee assignments)

A volunteer at the Arcadia Library since 2022  
Member of the Arcadia Library Friends of the Library Board.  
A poll worker for the 2024 presidential election.

### PLEASE DESCRIBE ANY BACKGROUND, TRAINING, OR INTERESTS THAT QUALIFY YOU AS AN APPOINTEE

I have volunteered at the Arcadia Public Library Bookstore for 3 years, in December 2024 I created an EBay website for the Library Bookstore to increase sales and give more monetary support to the library programs, specifically the childrens summer programs. As a manager at COH, attended meetings and training for management .

### WHAT DO YOU SEE AS THE OBJECTIVES AND GOALS OF THE COMMISSION FOR WHICH YOU ARE APPLYING?

As a person on the library bookstore board, I want to be of further support to the library and the bookstore. I have gained much knowledge on how the bookstore supports the community and have ideas along with my coworkers to improve the support we give to the library and community.

ARE YOU AWARE OF THE TIME COMMITMENT NECESSARY TO FULFILL THE OBLIGATIONS OF AN APPOINTMENT TO THIS POSITION?

YES  NO

NOTE: FOR LIBRARY BOARD OF TRUSTEE & PLANNING COMMISSION APPLICATIONS ONLY

STATE LAW AND THE CITY CONFLICT OF INTEREST CODE REQUIRES THAT LIBRARY BOARD OF TRUSTEE MEMBERS AND PLANNING COMMISSIONERS FILE A STATEMENT OF ECONOMIC INTERESTS (FORM 700) ANNUALLY AS WELL AS RELATED FORMS WHEN ASSUMING AND LEAVING OFFICE (e.g. sources of income, loans, gifts, investments, interest in real property as required by state law). DO YOU AGREE TO FILE ALL REQUIRED FORMS IN A TIMELY MANNER AS REQUIRED BY THE CITY'S FILING OFFICIAL?

YES  NO

\*\*\*\*\*

**\*ARCADIA BEAUTIFUL APPLICANTS ONLY**

ARE YOU AWARE THAT THE PRIMARY FUNCTION OF THE ARCADIA BEAUTIFUL COMMISSION IS TO ACT AS JUDGES FOR THE COMMISSIONS AWARD PROGRAMS (Spring Home, Holiday Decoration, and Water Smart Hero awards)?

YES  NO

DO YOU HAVE THE ABILITY TO TRAVEL BY CAR DURING THE DAY AND IN THE EVENING FOR THE PURPOSE OF JUDGING?

YES  NO

THE ARCADIA BEAUTIFUL COMMISSION USUALLY HAS FOUR REGULAR MEETINGS EACH YEAR WITH ADDITIONAL MEETINGS AND/OR TIME COMMITMENTS SCHEDULED FOR THE PURPOSE OF CONDUCTING JUDGING FOR THE AWARD PROGRAMS, PARTICIPATING IN A 3-4 HOUR HOLIDAY DECORATION AWARD RECOGNITION EVENT, AND PARTICIPATING IN ARBOR DAY PROGRAMS. ADDITIONALLY, PRELIMINARY JUDGING FOR THE SPRING HOME AND HOLIDAY DECORATION AWARDS IS DONE WITH EACH COMMISSIONER TAKING RESPONSIBILITY FOR A SECTION OF THE CITY AND DRIVING THROUGH THE NEIGHBORHOODS TO SELECT THEIR NOMINATIONS FOR FINAL JUDGING BY THE COMMISSION. ARE YOU ABLE TO FULFILL THIS TIME COMMITMENT?

YES  NO

\*\*\*\*\*

I HEREBY CERTIFY THAT THE FOREGOING INFORMATION IS TRUE AND CORRECT TO THE BEST OF MY KNOWLEDGE.

[Redacted Signature]

DATE

NOTE: The City of Arcadia reserves the right to use the information provided on this application to verify your residential address and voter registration status. The information provided on this application is for internal use only and confidential information will not be released to the public.

PLEASE SUBMIT YOUR COMPLETED APPLICATION TO: CITY CLERK'S OFFICE  
240 W. HUNTINGTON DRIVE  
ARCADIA, CA 91007

OR

Email us at [CityClerk@ArcadiaCA.gov](mailto:CityClerk@ArcadiaCA.gov)

Questions? Please contact us at (626) 574-5455

## **City of Arcadia Boards & Commissions Information**

The City Council of the City of Arcadia appoints members to seven boards and/or commissions to act in an advisory capacity. Following is a brief description of each.

**Arcadia Beautiful Commission:** Seven (7) members usually meet at four “regular” meetings each year with additional meetings and/or time commitments scheduled for the purpose of conducting judging for the Arcadia Beautiful, Holiday Decoration, and Water Smart Hero award programs, participating in a recognition event and community outreach for the holiday awards in December and attending an Arbor Day Celebration.

**Arcadia Museum Commission:** Five (5) members meet on the first Wednesday of every other month at 5:00 p.m., as an advisory capacity to all matters pertaining to the museum.

**Human Resources Commission:** Five (5) members meet the second Thursday of each month at 5:30 p.m., on policies concerning personnel administration, position classification and employee discipline and grievance.

**Library Board of Trustees:** Five (5) members meet on the third Thursday of each month at 4:30 p.m., to direct the administration and operation of the City library system.

**Planning Commission:** Five (5) members meet on the second and fourth Tuesday of each month at 7:00 p.m., to review matters affecting the physical development of the City.

**Recreation Commission:** Five (5) members meet the second Wednesday of each month at 6:00 p.m., to discuss matters pertaining to community recreation and parks.

**Senior Citizens’ Commission:** Eight (8) members meet the first Thursday of each month at 4:00 p.m., to provide leadership for the coordination of senior citizen activities.

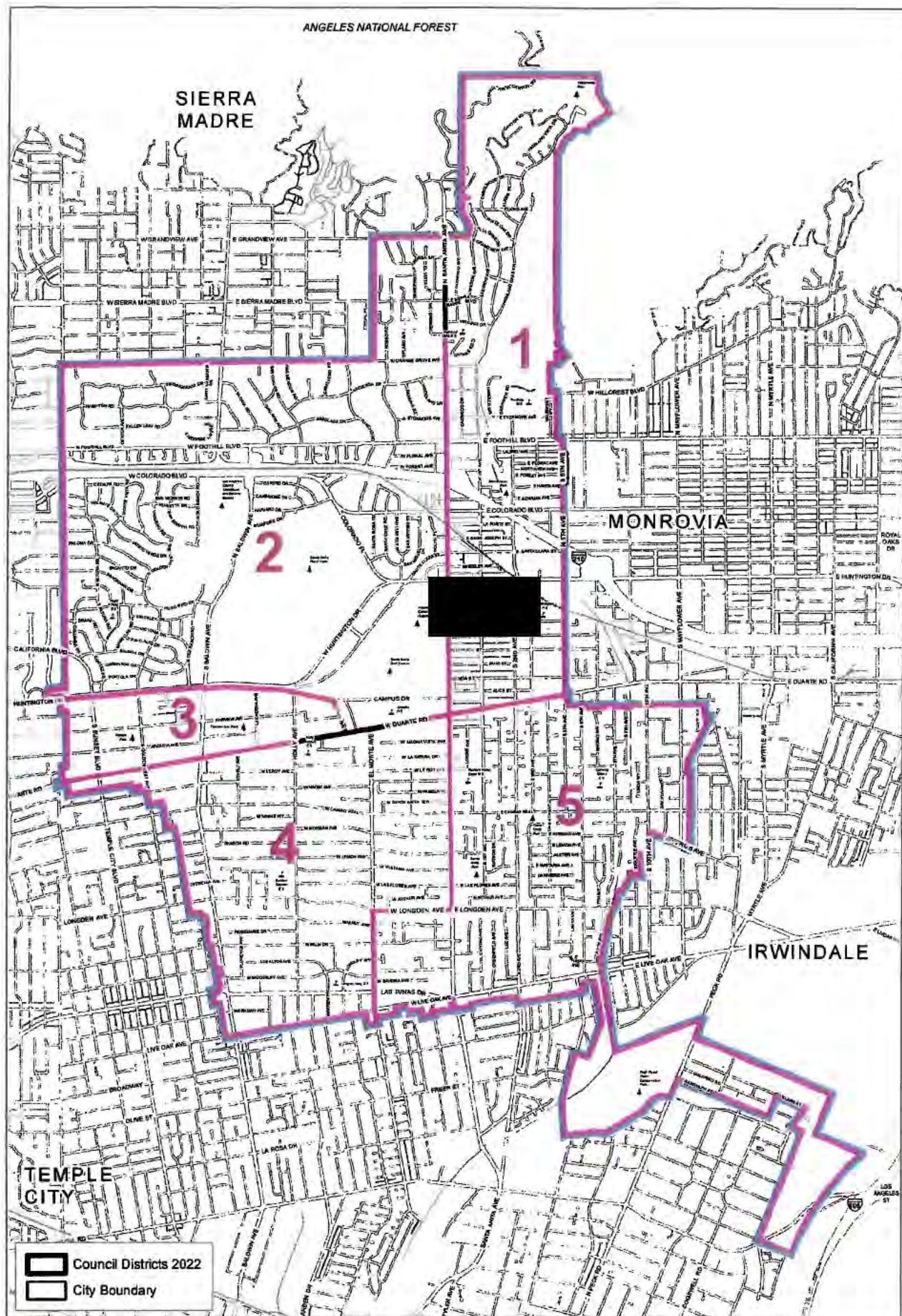

**Council District**  
*City of Arcadia, California*

# **PLANNING COMMISSION APPLICANTS**

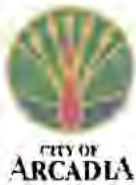

# City of Arcadia Board/Commission Application

RECEIVED

MAY 6 2026

CITY OF ARCADIA  
CITY CLERK

PLEASE PLACE A CHECK MARK NEXT TO THE BOARD OR COMMISSION FOR WHICH YOU WOULD LIKE TO APPLY (more than one selection may be made):

- |  |  |
|--|--|
| <input type="checkbox"/> Arcadia Beautiful Commission* | <input checked="" type="checkbox"/> Planning Commission  |
| <input type="checkbox"/> Arcadia Museum Commission     | <input type="checkbox"/> Recreation and Parks Commission |
| <input type="checkbox"/> Human Resources Commission    | <input type="checkbox"/> Senior Citizens Commission      |
| <input type="checkbox"/> Library Board of Trustees     | <input type="checkbox"/> Arcadia Health Commission       |

NAME Domenico Tallerico DATE OF BIRTH (mm/dd/yyyy) [REDACTED]  
FIRST LAST

RESIDENTIAL ADDRESS [REDACTED]  
(Note: Cannot be a mailing address or PO Box)

BUSINESS ADDRESS (HEALTH COMMISSION ONLY) As above

I CERTIFY THAT I AM A RESIDENT OF DISTRICT  ONE  TWO  THREE  FOUR  FIVE  
 N/A (Health Commission Only)

PHONE NUMBER [REDACTED] EMAIL ADDRESS [REDACTED]

OCCUPATION Certified Public Accountant EMPLOYER Self

ARE YOU AN ARCADIA REGISTERED VOTER?  YES  NO

HOW LONG HAVE YOU BEEN A RESIDENT? (If Applicable) 20 years

PLEASE ANSWER THE QUESTIONS BELOW. YOU MAY USE ADDITIONAL SHEETS OF PAPER AS NECESSARY.

**EDUCATION (Include professional or vocational licenses or certificates)**  
MBA San Francisco State; BA Economics UC Berkeley; Tax Courses Golden Gate University  
CPA, Certified Information Systems Auditor, Certified Internal Auditor, Chartered Bank Auditor (expired), Series 7 & 63 trading licenses (Registered Representative Licenses for selling/managing securities now expired)  
**COMMUNITY INVOLVEMENT (List organization memberships and committee assignments)**  
Planning Commission since July 19, 2022  
Neighborhood Watch

**PLEASE DESCRIBE ANY BACKGROUND, TRAINING, OR INTERESTS THAT QUALIFY YOU AS AN APPOINTEE**  
Planning Commission  
Architecture courses  
Frequent and active attendee at City Council meetings  
Love for living in Arcadia

**WHAT INTERESTS YOU ABOUT THE BOARD/COMMISSION YOU ARE APPLYING FOR?**  
Living in Arcadia prompted my initial interest in serving on the Planning Commission; having served now for almost four years has further enhanced this interest.  
Arcadia is a wonderful place to live whether to raise families, retire, or simply pursue whatever one's interests. There are excellent schools, safety services, recreational pursuits, shopping, health providers, and housing opportunities. The views are magnificent as well! And as great a city as it is, it does need to be protected and enhanced. The Planning Commission is one way to keep vigilant over our fine quality of life!

ARE YOU AWARE OF THE TIME COMMITMENT NECESSARY TO FULFILL THE OBLIGATIONS OF AN APPOINTMENT TO THIS POSITION?

YES  NO

**NOTE: FOR LIBRARY BOARD OF TRUSTEE AND PLANNING COMMISSION APPLICATIONS ONLY**  
STATE LAW AND THE CITY CONFLICT OF INTEREST CODE REQUIRES THAT LIBRARY BOARD OF TRUSTEE MEMBERS AND PLANNING COMMISSIONERS FILE A STATEMENT OF ECONOMIC INTERESTS (FORM 700) ANNUALLY AS WELL AS RELATED FORMS WHEN ASSUMING AND LEAVING OFFICE (e.g. sources of income, loans, gifts, investments, interest in real property as required by state law). DO YOU AGREE TO FILE ALL REQUIRED FORMS IN A TIMELY MANNER AS REQUIRED BY THE CITY'S FILING OFFICIAL?

YES  NO

---

**\*ARCADIA BEAUTIFUL APPLICANTS ONLY**

ARE YOU AWARE THAT THE PRIMARY FUNCTION OF THE ARCADIA BEAUTIFUL COMMISSION IS TO ACT AS JUDGES FOR THE COMMISSIONS AWARD PROGRAMS (Spring Home, Holiday Decoration, and Water Smart Hero awards)?

YES  NO

DO YOU HAVE THE ABILITY TO TRAVEL BY CAR DURING THE DAY AND IN THE EVENING FOR THE PURPOSE OF JUDGING?

YES  NO

THE ARCADIA BEAUTIFUL COMMISSION USUALLY HAS FOUR REGULAR MEETINGS EACH YEAR WITH ADDITIONAL MEETINGS AND/OR TIME COMMITMENTS SCHEDULED FOR THE PURPOSE OF CONDUCTING JUDGING FOR THE AWARD PROGRAMS, PARTICIPATING IN A 3-4 HOUR HOLIDAY DECORATION AWARD RECOGNITION EVENT, AND PARTICIPATING IN ARBOR DAY PROGRAMS. ADDITIONALLY, PRELIMINARY JUDGING FOR THE SPRING HOME AND HOLIDAY DECORATION AWARDS IS DONE WITH EACH COMMISSIONER TAKING RESPONSIBILITY FOR A SECTION OF THE CITY AND DRIVING THROUGH THE NEIGHBORHOODS TO SELECT THEIR NOMINATIONS FOR FINAL JUDGING BY THE COMMISSION. ARE YOU ABLE TO FULFILL THIS TIME COMMITMENT?

YES  NO

---

I HEREBY CERTIFY THAT THE FOREGOING INFORMATION IS TRUE AND CORRECT TO THE BEST OF MY KNOWLEDGE.

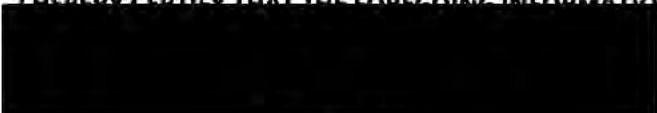

SIGNATURE

May 5, 2026

DATE

NOTE: The City of Arcadia reserves the right to use the information provided on this application to verify your residential address and voter registration status. The information provided on this application is for internal use only and confidential information will not be released to the public.

PLEASE SUBMIT YOUR COMPLETED APPLICATION TO: CITY CLERK'S OFFICE  
240 W. HUNTINGTON DRIVE  
ARCADIA, CA 91007

OR

Email us at [CityClerk@ArcadiaCA.gov](mailto:CityClerk@ArcadiaCA.gov)



Questions? Please contact us at (626) 574-5455

SIERRA MADRE

MONROVIA

IRWINDALE

TEMPLE CITY

 Council Districts 2022  
 City Boundary

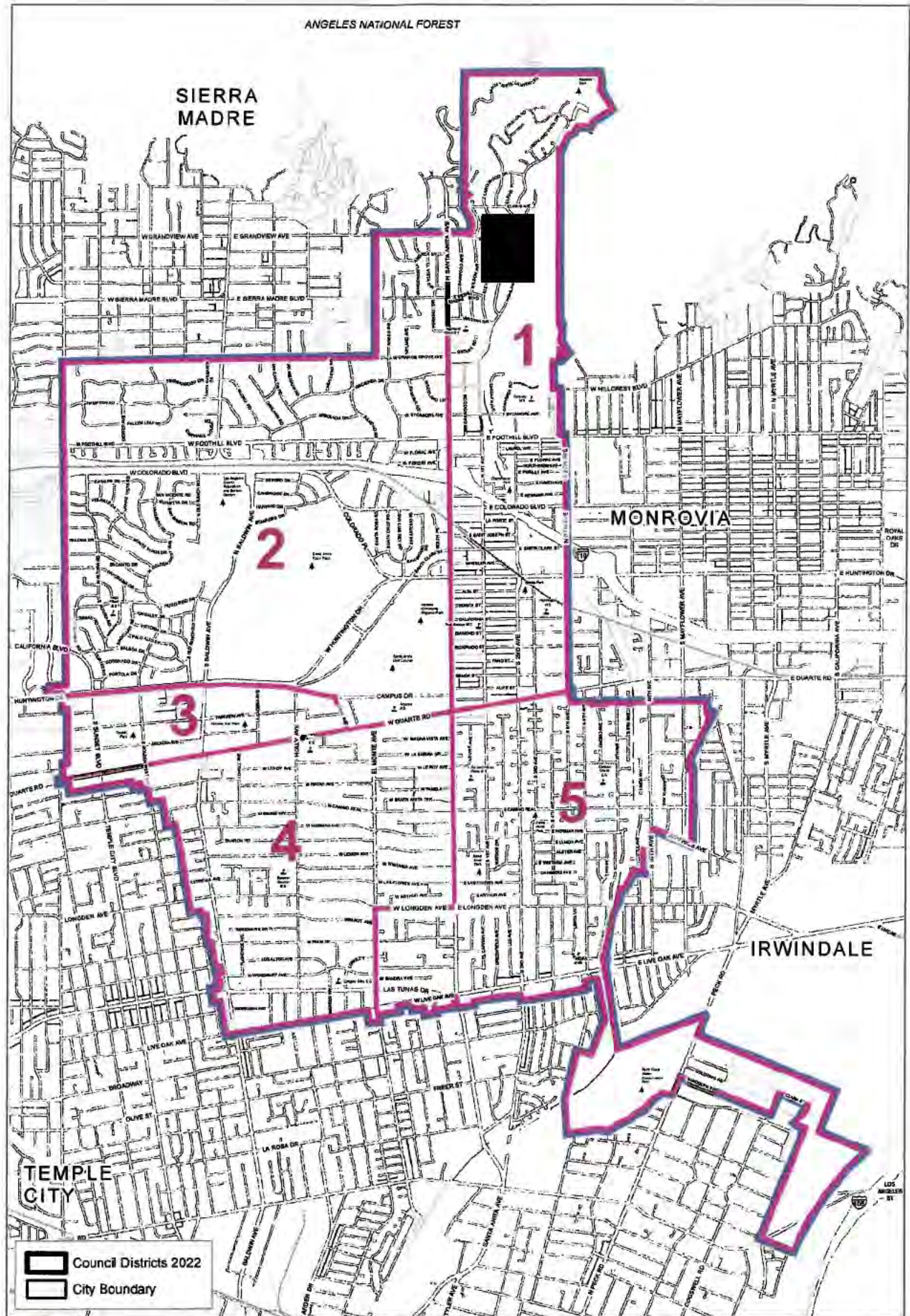

**Council District**  
City of Arcadia, California



# City of Arcadia Board/Commission Application

RECEIVED

MAY 26 2026

CITY OF ARCADIA  
CITY CLERK

PLEASE PLACE A CHECK MARK NEXT TO THE BOARD OR COMMISSION FOR WHICH YOU WOULD LIKE TO APPLY (more than one selection may be made):

- |  |  |
|--|--|
| <input type="checkbox"/> Arcadia Beautiful Commission* | <input checked="" type="checkbox"/> Planning Commission  |
| <input type="checkbox"/> Arcadia Museum Commission     | <input type="checkbox"/> Recreation and Parks Commission |
| <input type="checkbox"/> Human Resources Commission    | <input type="checkbox"/> Senior Citizens Commission      |
| <input type="checkbox"/> Library Board of Trustees     | <input type="checkbox"/> Arcadia Health Commission       |

NAME Hui Angela DATE OF BIRTH (mm/dd/yyyy) [REDACTED]

FIRST LAST

RESIDENTIAL ADDRESS [REDACTED] Arcadia, CA 91006

(Note: Cannot be a mailing address or PO Box)

BUSINESS ADDRESS (HEALTH COMMISSION ONLY) \_\_\_\_\_

I CERTIFY THAT I AM A RESIDENT OF DISTRICT  ONE  TWO  THREE  FOUR  FIVE  
 N/A (Health Commission Only)

PHONE NUMBER [REDACTED] EMAIL ADDRESS [REDACTED]

OCCUPATION Construction and Commercial Real Estate EMPLOYER \_\_\_\_\_

ARE YOU AN ARCADIA REGISTERED VOTER?  YES  NO

HOW LONG HAVE YOU BEEN A RESIDENT? (If Applicable) since 1997

PLEASE ANSWER THE QUESTIONS BELOW. YOU MAY USE ADDITIONAL SHEETS OF PAPER AS NECESSARY.

**EDUCATION (Include professional or vocational licenses or certificates)**

Please see attached page.

**COMMUNITY INVOLVEMENT (List organization memberships and committee assignments)**

Please see attached page.

**PLEASE DESCRIBE ANY BACKGROUND, TRAINING, OR INTERESTS THAT QUALIFY YOU AS AN APPOINTEE**

Currently, this is my 4th year as Planning Commissioner for the City of Arcadia. Please see attached page for more details.

**WHAT INTERESTS YOU ABOUT THE BOARD/COMMISSION YOU ARE APPLYING FOR?**

I would like to continue to serve my second 4-year term as Planning Commissioner. Please see attached page for more details.

ARE YOU AWARE OF THE TIME COMMITMENT NECESSARY TO FULFILL THE OBLIGATIONS OF AN APPOINTMENT TO THIS POSITION?

YES  NO

NOTE: FOR LIBRARY BOARD OF TRUSTEE AND PLANNING COMMISSION APPLICATIONS ONLY  
STATE LAW AND THE CITY CONFLICT OF INTEREST CODE REQUIRES THAT LIBRARY BOARD OF TRUSTEE MEMBERS AND PLANNING COMMISSIONERS FILE A STATEMENT OF ECONOMIC INTERESTS (FORM 700) ANNUALLY AS WELL AS RELATED FORMS WHEN ASSUMING AND LEAVING OFFICE (e.g. sources of income, loans, gifts, investments, interest in real property as required by state law). DO YOU AGREE TO FILE ALL REQUIRED FORMS IN A TIMELY MANNER AS REQUIRED BY THE CITY'S FILING OFFICIAL?

YES  NO

---

**\*ARCADIA BEAUTIFUL APPLICANTS ONLY**

ARE YOU AWARE THAT THE PRIMARY FUNCTION OF THE ARCADIA BEAUTIFUL COMMISSION IS TO ACT AS JUDGES FOR THE COMMISSIONS AWARD PROGRAMS (Spring Home, Holiday Decoration, and Water Smart Hero awards)?

YES  NO

DO YOU HAVE THE ABILITY TO TRAVEL BY CAR DURING THE DAY AND IN THE EVENING FOR THE PURPOSE OF JUDGING?

YES  NO

THE ARCADIA BEAUTIFUL COMMISSION USUALLY HAS FOUR REGULAR MEETINGS EACH YEAR WITH ADDITIONAL MEETINGS AND/OR TIME COMMITMENTS SCHEDULED FOR THE PURPOSE OF CONDUCTING JUDGING FOR THE AWARD PROGRAMS, PARTICIPATING IN A 3-4 HOUR HOLIDAY DECORATION AWARD RECOGNITION EVENT, AND PARTICIPATING IN ARBOR DAY PROGRAMS. ADDITIONALLY, PRELIMINARY JUDGING FOR THE SPRING HOME AND HOLIDAY DECORATION AWARDS IS DONE WITH EACH COMMISSIONER TAKING RESPONSIBILITY FOR A SECTION OF THE CITY AND DRIVING THROUGH THE NEIGHBORHOODS TO SELECT THEIR NOMINATIONS FOR FINAL JUDGING BY THE COMMISSION. ARE YOU ABLE TO FULFILL THIS TIME COMMITMENT?

YES  NO

---

STATEMENT IS TRUE AND CORRECT TO THE BEST OF MY KNOWLEDGE.

05/22/2026

DATE

NOTE: THE CITY OF ARCADIA RESERVES THE RIGHT TO USE THE INFORMATION PROVIDED ON THIS APPLICATION TO VERIFY YOUR RESIDENTIAL ADDRESS AND VOTER REGISTRATION STATUS. THE INFORMATION PROVIDED ON THIS APPLICATION IS FOR INTERNAL USE ONLY AND CONFIDENTIAL INFORMATION WILL NOT BE RELEASED TO THE PUBLIC.

PLEASE SUBMIT YOUR COMPLETED APPLICATION TO: CITY CLERK'S OFFICE  
240 W. HUNTINGTON DRIVE  
ARCADIA, CA 91007

OR

Email us at [CityClerk@ArcadiaCA.gov](mailto:CityClerk@ArcadiaCA.gov)

Questions? Please contact us at (626) 574-5455

**PLEASE LIST YOUR EDUCATION (Include professional or vocational licenses or certificates)**

**University of Southern California**

- Master of Business Administration (MBA), Finance 1995
- Bachelor of Science in Business (Marshall Business School), emphasis in Banking and Investment, 1990

**PLEASE DETAIL YOUR ARCADIA COMMUNITY INVOLVEMENT (List of organization memberships, volunteer assignments, elected or appointed office, etc.)**

My Arcadia community involvement has to trace back since my two sons started their kindergarten school life.

**Camino Grove Elementary School**

- Teacher aid and classroom mom
  - o Stayed inside a classroom once a week for each boy on grading class work; did artwork for the classroom; post classwork of students onto bulletin board; did chores required from different teachers inside work room once or twice a week on top of a teacher aid and classroom mom, etc.
- PTSA aid
  - o Traffic aid (opened cars door and aid students to get off the cars safely in drive through drop off line); play different roles as assigned role in all school events, chaperones, etc.

**Dana Middle School**

- PTSA aid - Chaperone and an officer position at Arcadia Music Club
  - o Ensure the safety of our Musicians for all performance at school and outside; helped loaded and unloaded all music instruments at each performance, etc.
  - o Actively volunteer at all schools event
  - o Work room mom once a week
- Head Coach for 4 years – Science Olympiad Club 2011-2012, 2012-2013, 2013-2014, 2014-2015
  - o Set coaching team requirements; organized weekly teaching materials in coach clinics with Dana coaches;
  - o Represented the school's Science Olympiad Club (only Dana Middle School has Science Olympiad Club but not First Avenue nor Foothill) to take the team (selected top 15 finalists students and alternates) to compete with many top schools in a) Invitational, b) Los Angeles Regional, and c) State level competition (as Dana earned in top 6) in about 23 events (Division B = middle school) in i) life, personal & social science, ii) earth & space science, iii) physical science & chemistry, iv) technology & engineering, v) inquiry & nature of science, vi) building events.
  - o Aside from solicit coaches of each 23 events from parents of which I am an event coach as well, manage the books and records, budgeting and finance, purchase building and coaching materials, design Team T-shirts yearly, arrange parties and weekly snacks for students, etc.

- Proud to say had lead and advanced the team to bring back with earned trophies and medals at each competition, particularly in a) invitational, b) Los Angeles Regional levels. Many paired students in each event did earn winning medals in State levels though.
- Not just weekly planning, coaching, overseeing the entire team at Dana Middle School, the final elimination process and judged the weekly progress of each students represented Dana through months of training (started in September or October and ended in around April – State level) required correct judgment to ensure the selected students were the best representatives for the 23 events.
- Encourage the young scientists to engage and learn to prepare them to continue the interests in science in high school, and prepare them to compete in Arcadia High School's Science Olympiad Team.
- School Site Council's parent representative for 2 terms as appointed by at then Principal Daniel Hacking

### **Arcadia High School**

- Board Member and Music Club Liaison for 2 years 2016-2017 and 2017- 2018 in Arcadia High School Chinese Parents Booster Club
- Chair and other event positions for a few years, 2015-2020 and 2022 (no event for 2021 due to campus closed caused by pandemic) in its annual fundraising event - Orchestra Benefit Dinner ("OBD") for Arcadia High School's Orchestra students and parents – NOTED my son is Class of 2017. I was heavily involved in OBD fundraising annually like a de facto Chair of the event successfully fundraised net of approximately \$35,000 annually. The latest event was on 02/22/2026.
- Usher in music performance, chaperone and events volunteerism in many Music Club events and activities
- PTSA aid – receive honorary service award from PTSA 2017
- Football Club – solicit sponsors and volunteerism in most of its organized events in fundraising
- School site Council's parent representative for 2 terms

### **Methodist Hospital Foundation – Crystal Ball 2018 (29<sup>th</sup> annual) and 2019 (30<sup>th</sup> annual) Committee Members**

- Responsible to look for sponsors and donors for its annual gala fundraiser in support of Methodist Hospital which proceeds of each year is mainly for the purchase of advance equipment for the hospital use. (For example: "proceeds for 2018 will support endovascular services and interventional radiology at Methodist Hospital to meet the increasing need of stroke patients who require immediate neuro-intervention, as well as patients with vascular disorders in need of intervention and who are best-served in a minimally invasive-setting." Methodist Hospital is very fortunate to able to hire Dr. K T Tan from another State to join in this particular field.

### **Others**

- Participate in community event from time to time
- Aid the community when needed – for example – assist to source PPE from various local donors, companies, organizations, etc. and arrange multiple deliveries to a) Methodist Hospital, b) Arcadia Police Department, c) Arcadia Fire Department / City of Arcadia
- Assist in event(s) fundraising and participation as invited and asked – such as for a) Arcadia Chinese Association , b) Arcadia Police Foundation, c) Arcadia Performing Arts Foundation, d) Arcadia Education Foundation
- Board member of Arcadia Performing Arts Foundation

**PLEASE DESCRIBE YOUR BACKGROUND, TRAINING, OR INTERESTS THAT QUALIFY YOU AS AN APPOINTEE.**

- After I obtained my bachelor and before I earned my MBA degree at USC, I started my first full time job at Cathay Bank in the lending side. I believe with my deep finance background and my long over 30 years in role of business development and managerial position in Construction and Commercial Real Estate Lending has sharpened my communication and people skills in relationship building that shall assist as a good liaison with our residents.
- Besides my education and career background in construction and commercial real estate lending, currently served the 4<sup>th</sup> year as Planning Commissioner for the City of Arcadia shall add value serving the second term. During my first term on the Planning Commission, I embraced the responsibility of reviewing some of the most significant and transformative land use files. As the state declared housing crises with many new approved bills, established Housing Elements, inclusionary housing ordinance, etc. , though I am learning every day, my 4 years of experience as Planning Commissioner has shaped me as a better candidate than others. I would continue to maintaining a transparent, fair, and welcoming environment during public hearings so that all community members feel heard.



**WHAT INTERESTS YOU ABOUT THE BOARD / COMMISSION YOU ARE APPLYING FOR?**

Like to share my visions based on my knowledge, particularly in commercial real estate and construction lending (good fit for planning commission position), people and managerial skills, and background and continue to work with the city in a better way in its short and long term plan (not just in lending, I have good sense in budgeting, finance, etc. via work and earned MBA degree);

- Considered myself a fair and righteous person (skill set require for both planning commission). Shall I not know anything, I will try to find the answers myself via researching, and then I will ask shall I want to understand more.
- A bridge and a well representative for the growing (60%+) Asian population as I can read, write and speak Chinese (both in Cantonese and Mandarin) – as Asian culture might be slightly different, I may understand its project design;
- In the last four years, I am proud to have the opportunity to review the application with my colleagues for several sizable projects, such as Alexan Azalea, Alexan Aroyo, Arcadia Town

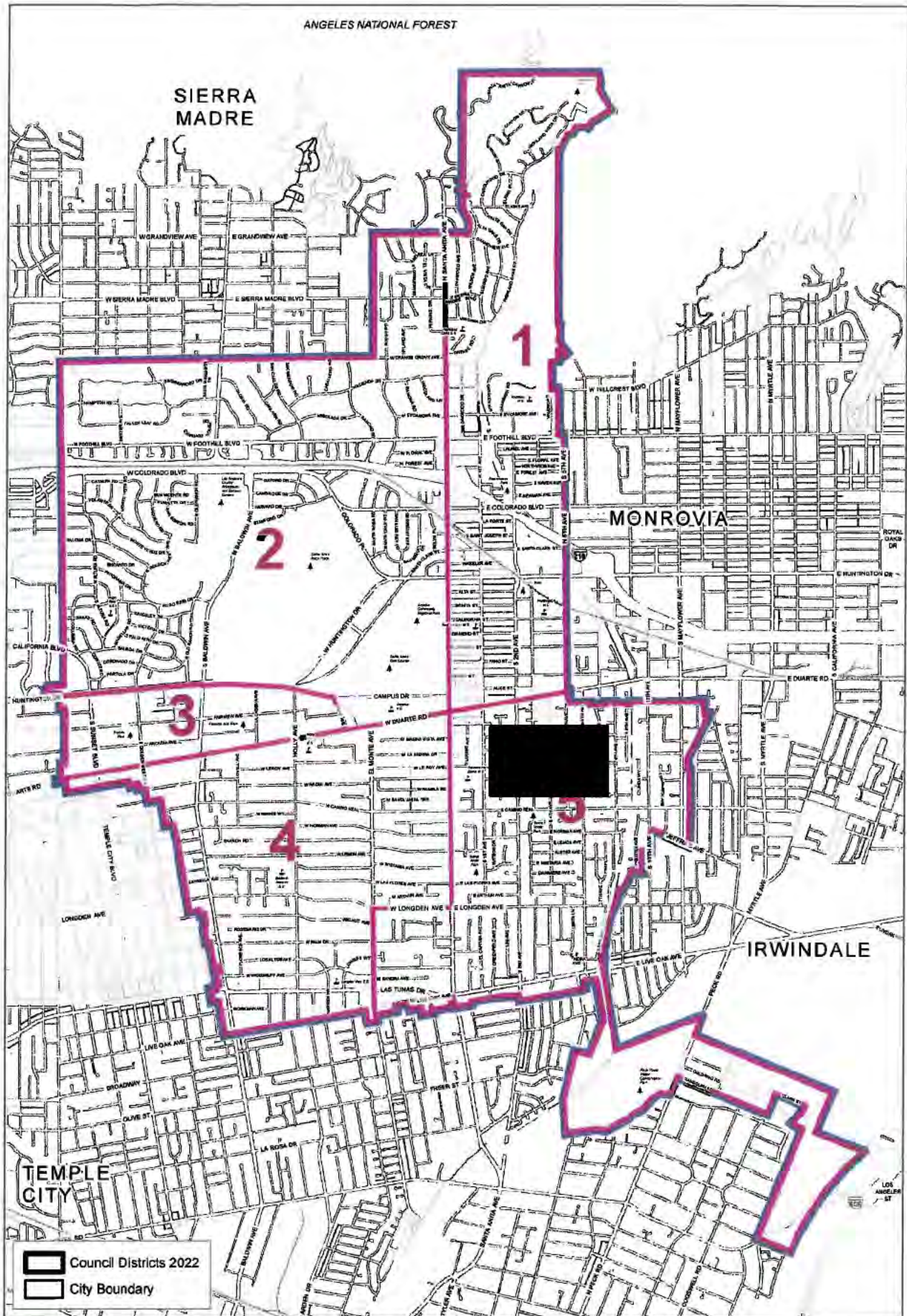
Center, The Ivy Senior Assisted Living Care Facility, The Hilton Hotel's Roof Top, The Tempo by Hilton Hotel, etc.



 Council Districts 2022  
 City Boundary



**Council District**  
City of Arcadia, California

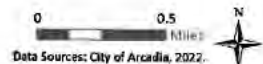



# City of Arcadia Board/Commission Application

RECEIVED  
CITY OF ARCADIA

MAR 16 2026

CITY MANAGER

PLEASE PLACE A CHECK MARK NEXT TO THE BOARD OR COMMISSION FOR WHICH YOU WOULD LIKE TO APPLY (more than one selection may be made):

- |   |   |
|---|---|
| <input checked="" type="checkbox"/> Arcadia Beautiful Commission* | <input checked="" type="checkbox"/> Planning Commission             |
| <input type="checkbox"/> Arcadia Museum Commission                | <input checked="" type="checkbox"/> Recreation and Parks Commission |
| <input checked="" type="checkbox"/> Human Resources Commission    | <input checked="" type="checkbox"/> Senior Citizens Commission      |
| <input checked="" type="checkbox"/> Library Board of Trustees     | <input type="checkbox"/> Arcadia Health Commission                  |

NAME JOHNNY TSENG DATE OF BIRTH (mm/dd/yyyy) [REDACTED]

FIRST LAST

RESIDENTIAL ADDRESS [REDACTED] 91006

(Note: Cannot be a mailing address or PO Box)

BUSINESS ADDRESS (HEALTH COMMISSION ONLY) \_\_\_\_\_

I CERTIFY THAT I AM A RESIDENT OF DISTRICT  ONE  TWO  THREE  FOUR  FIVE  
 N/A (Health Commission Only)

PHONE NUMBER [REDACTED] EMAIL ADDRESS [REDACTED]

OCCUPATION Teacher EMPLOYER Hacienda La Puente Unified School District

ARE YOU AN ARCADIA REGISTERED VOTER?  YES  NO

HOW LONG HAVE YOU BEEN A RESIDENT? (If Applicable) 19

PLEASE ANSWER THE QUESTIONS BELOW. YOU MAY USE ADDITIONAL SHEETS OF PAPER AS NECESSARY.

**EDUCATION (Include professional or vocational licenses or certificates)**

Active Community Member, Interest in community service, betterment of the City of Arcadia, and highly enthusiastic and involved. Would be amazing to have this opportunity to make a difference.

**COMMUNITY INVOLVEMENT (List organization memberships and committee assignments)**

Active Community Member, Interest in community service, betterment of the City of Arcadia, and highly enthusiastic and involved. Would be amazing to have this opportunity to make a difference.

**PLEASE DESCRIBE ANY BACKGROUND, TRAINING, OR INTERESTS THAT QUALIFY YOU AS AN APPOINTEE**

Active Community Member, Interest in community service, betterment of the City of Arcadia, and highly enthusiastic and involved. Would be amazing to have this opportunity to make a difference.

**WHAT INTERESTS YOU ABOUT THE BOARD/COMMISSION YOU ARE APPLYING FOR?**

Active Community Member, Interest in community service, betterment of the City of Arcadia, and highly enthusiastic and involved. Would be amazing to have this opportunity to make a difference.

ARE YOU AWARE OF THE TIME COMMITMENT NECESSARY TO FULFILL THE OBLIGATIONS OF AN APPOINTMENT TO THIS POSITION?

YES  NO

NOTE: FOR LIBRARY BOARD OF TRUSTEE AND PLANNING COMMISSION APPLICATIONS ONLY  
STATE LAW AND THE CITY CONFLICT OF INTEREST CODE REQUIRES THAT LIBRARY BOARD OF TRUSTEE MEMBERS AND PLANNING COMMISSIONERS FILE A STATEMENT OF ECONOMIC INTERESTS (FORM 700) ANNUALLY AS WELL AS RELATED FORMS WHEN ASSUMING AND LEAVING OFFICE (e.g. sources of income, loans, gifts, investments, interest in real property as required by state law). DO YOU AGREE TO FILE ALL REQUIRED FORMS IN A TIMELY MANNER AS REQUIRED BY THE CITY'S FILING OFFICIAL?

YES  NO

---

**\*ARCADIA BEAUTIFUL APPLICANTS ONLY**

ARE YOU AWARE THAT THE PRIMARY FUNCTION OF THE ARCADIA BEAUTIFUL COMMISSION IS TO ACT AS JUDGES FOR THE COMMISSIONS AWARD PROGRAMS (Spring Home, Holiday Decoration, and Water Smart Hero awards)?

YES  NO

DO YOU HAVE THE ABILITY TO TRAVEL BY CAR DURING THE DAY AND IN THE EVENING FOR THE PURPOSE OF JUDGING?

YES  NO

THE ARCADIA BEAUTIFUL COMMISSION USUALLY HAS FOUR REGULAR MEETINGS EACH YEAR WITH ADDITIONAL MEETINGS AND/OR TIME COMMITMENTS SCHEDULED FOR THE PURPOSE OF CONDUCTING JUDGING FOR THE AWARD PROGRAMS, PARTICIPATING IN A 3-4 HOUR HOLIDAY DECORATION AWARD RECOGNITION EVENT, AND PARTICIPATING IN ARBOR DAY PROGRAMS. ADDITIONALLY, PRELIMINARY JUDGING FOR THE SPRING HOME AND HOLIDAY DECORATION AWARDS IS DONE WITH EACH COMMISSIONER TAKING RESPONSIBILITY FOR A SECTION OF THE CITY AND DRIVING THROUGH THE NEIGHBORHOODS TO SELECT THEIR NOMINATIONS FOR FINAL JUDGING BY THE COMMISSION. ARE YOU ABLE TO FULFILL THIS TIME COMMITMENT?

YES  NO

---

I HEREBY CERTIFY THAT THE INFORMATION IS TRUE AND CORRECT TO THE BEST OF MY KNOWLEDGE.

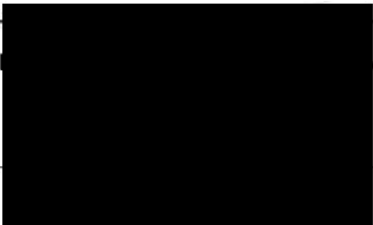

3-6-26  
DATE

NOTE: The City of Arcadia reserves the right to use the information provided on this application to verify your residential address and voter registration status. The information provided on this application is for internal use only and confidential information will not be released to the public.

PLEASE SUBMIT YOUR COMPLETED APPLICATION TO: CITY CLERK'S OFFICE  
240 W. HUNTINGTON DRIVE  
ARCADIA, CA 91007

OR

Email us at [CityClerk@ArcadiaCA.gov](mailto:CityClerk@ArcadiaCA.gov)

Questions? Please contact us at (626) 574-5455

CITY CLERK'S OFFICE  
240 W. HUNTINGTON DRIVE ARCADIA, CA 91007

City Clerk's Office  
City of Arcadia  
P. O. Box 60021  
Arcadia, California 91066

Masters in Arts- Educational Leadership  
Bachelor's in Arts- Child Development

**Arcadia High School Orchestra Benefit Dinner Committee Chair, San Marino Chinese School Board Member, AHS Hispanic Parent Booster Club Vice President, Arcadia Troop 104/333 Assistant Scout Master, Arcadia Citizens Oversight Committee Member. Arcadia Neighborhood Watch Captain**

**Active Community Member, Interest in community service, betterment of the City of Arcadia, and highly enthusiastic and involved. Would be amazing to have this opportunity to make a difference.**

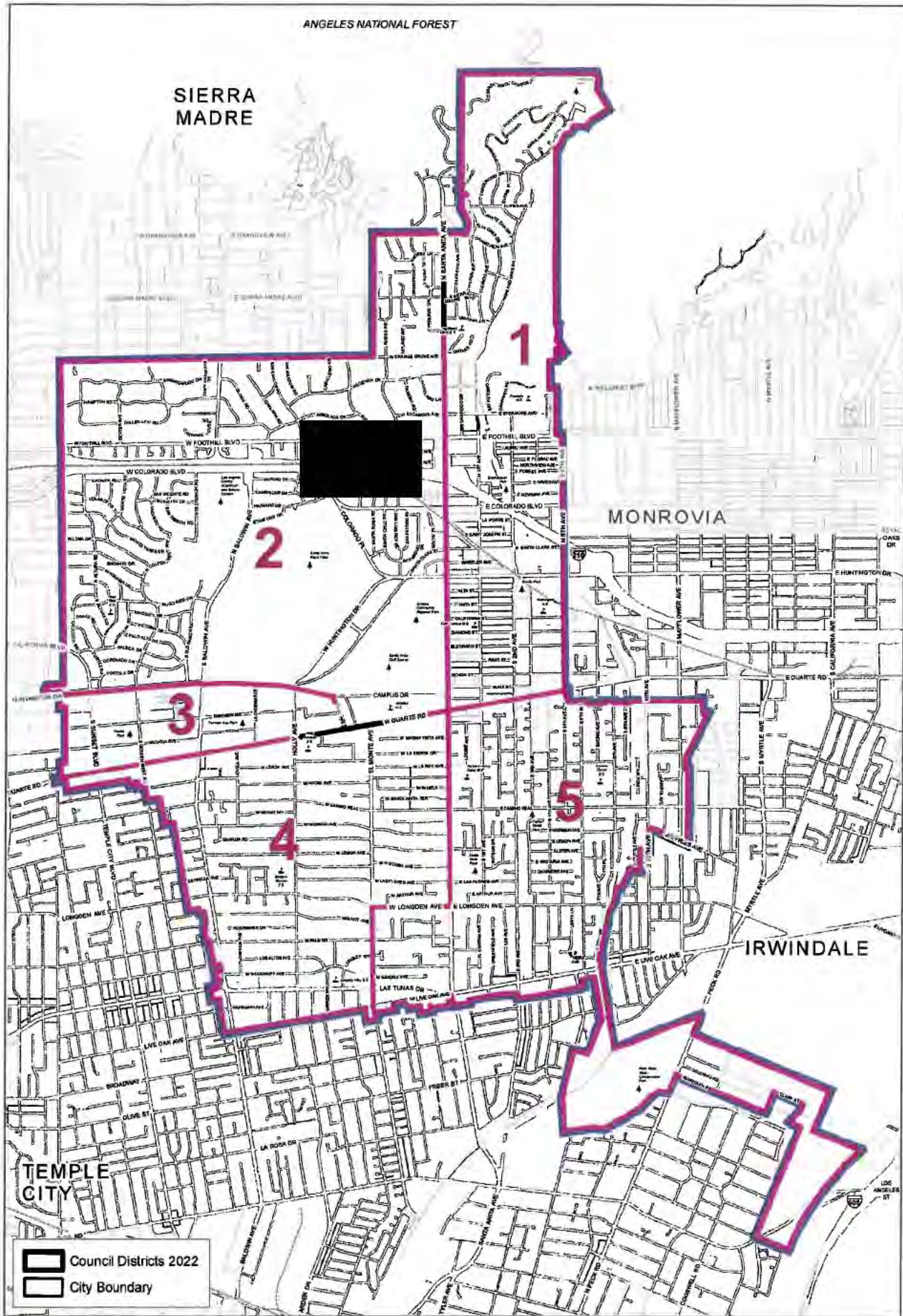

SIERRA MADRE



MONROVIA

IRWINDALE

TEMPLE CITY

 Council Districts 2022  
 City Boundary

**Council District**  
 City of Arcadia, California



# City of Arcadia Board/Commission Application

RECEIVED

APR 29 2026

PLEASE PLACE A CHECK MARK NEXT TO THE BOARD OR COMMISSION FOR WHICH YOU WOULD LIKE TO APPLY (more than one selection may be made):

- Arcadia Beautiful Commission\*
- Arcadia Museum Commission
- Human Resources Commission
- Library Board of Trustees
- Planning Commission
- Recreation and Parks Commission
- Senior Citizens Commission
- Arcadia Health Commission

NAME Chang Lee DATE OF BIRTH (mm/dd/yyyy) [REDACTED]  
FIRST LAST

RESIDENTIAL ADDRESS [REDACTED] Arcadia, CA 91006  
(Note: Cannot be a mailing address or PO Box)

BUSINESS ADDRESS (HEALTH COMMISSION ONLY) \_\_\_\_\_

I CERTIFY THAT I AM A RESIDENT OF DISTRICT  ONE  TWO  THREE  FOUR  FIVE  
 N/A (Health Commission Only)

PHONE NUMBER [REDACTED] EMAIL ADDRESS [REDACTED]

OCCUPATION General Contractor / Developer EMPLOYER CLEW Development, Inc

ARE YOU AN ARCADIA REGISTERED VOTER?  YES  NO

HOW LONG HAVE YOU BEEN A RESIDENT? (if Applicable) 2.7 years

PLEASE ANSWER THE QUESTIONS BELOW. YOU MAY USE ADDITIONAL SHEETS OF PAPER AS NECESSARY

### EDUCATION (Include professional or vocational licenses of certificates)

BS Chemical Engineering, University of Southern Cal, 1976-1980  
Exec MBA, Hankuk University of Foreign Studies, 2007-2008; General Contractor, CA Lic No B590162, 1989-Present

### COMMUNITY INVOLVEMENT (List organization memberships and committee assignments)

City of Arcadia, Human Resources Commissioner, 2024-Present  
City of Glendale, Planning Commissioner, 2009-2024; CDBG Commission, 2007-2009  
City of Glendale, President, Korea Sister City Assoc. 2010-Present; City of LA, LAPD Boosters, President 2025-Present

### PLEASE DESCRIBE ANY BACKGROUND, TRAINING, OR INTERESTS THAT QUALIFY YOU AS AN APPOINTEE

Facilities Project Specialist, Rocketdyne, Rockwell International, 1985-1987  
Facilities Project Manager, Rocketdyne, Boeing Aerospace, 1987-1990  
Development Chief Advisor, Bandodela Corp, 2022-Present  
Advisor, California Korean Contractor's Assoc, 2024-Present

### WHAT INTERESTS YOU ABOUT THE BOARD/COMMISSION YOU ARE APPLYING FOR?

Tasked with the stewardship of the community's future, the Commissioner must balance the principles of sustainable development with the preservation of the unique character and integrity of established residential neighborhoods. This role requires to be a fair arbiter of the public interest, ensuring that every development and policy decision contributes to a safe, pleasant, and enduring urban fabric. My experience as the Glendale Planning Commissioner for the past 17 years has prepared me to enthusiastically serve the City of Arcadia.

ARE YOU AWARE OF THE TIME COMMITMENT NECESSARY TO FULFILL THE OBLIGATIONS OF AN APPOINTMENT TO THIS POSITION?

YES  NO

NOTE: FOR LIBRARY BOARD OF TRUSTEE AND PLANNING COMMISSION APPLICATIONS ONLY  
STATE LAW AND THE CITY CONFLICT OF INTEREST CODE REQUIRES THAT LIBRARY BOARD OF TRUSTEE MEMBERS AND PLANNING COMMISSIONERS FILE A STATEMENT OF ECONOMIC INTERESTS (FORM 700) ANNUALLY AS WELL AS RELATED FORMS WHEN ASSUMING AND LEAVING OFFICE (e.g. sources of income, loans, gifts, investments, interest in real property as required by state law). DO YOU AGREE TO FILE ALL REQUIRED FORMS IN A TIMELY MANNER AS REQUIRED BY THE CITY'S FILING OFFICIAL?

YES  NO

---

**\*ARCADIA BEAUTIFUL APPLICANTS ONLY**

ARE YOU AWARE THAT THE PRIMARY FUNCTION OF THE ARCADIA BEAUTIFUL COMMISSION IS TO ACT AS JUDGES FOR THE COMMISSIONS AWARD PROGRAMS (Spring Home, Holiday Decoration, and Water Smart Hero awards)?

YES  NO

DO YOU HAVE THE ABILITY TO TRAVEL BY CAR DURING THE DAY AND IN THE EVENING FOR THE PURPOSE OF JUDGING?

YES  NO

THE ARCADIA BEAUTIFUL COMMISSION USUALLY HAS FOUR REGULAR MEETINGS EACH YEAR WITH ADDITIONAL MEETINGS AND/OR TIME COMMITMENTS SCHEDULED FOR THE PURPOSE OF CONDUCTING JUDGING FOR THE AWARD PROGRAMS, PARTICIPATING IN A 3-4 HOUR HOLIDAY DECORATION AWARD RECOGNITION EVENT, AND PARTICIPATING IN ARBOR DAY PROGRAMS. ADDITIONALLY, PRELIMINARY JUDGING FOR THE SPRING HOME AND HOLIDAY DECORATION AWARDS IS DONE WITH EACH COMMISSIONER TAKING RESPONSIBILITY FOR A SECTION OF THE CITY AND DRIVING THROUGH THE NEIGHBORHOODS TO SELECT THEIR NOMINATIONS FOR FINAL JUDGING BY THE COMMISSION. ARE YOU ABLE TO FULFILL THIS TIME COMMITMENT?

YES  NO

---

I HEREBY CERTIFY THAT THE FOREGOING INFORMATION IS TRUE AND CORRECT TO THE BEST OF MY KNOWLEDGE.



SIGNATURE

April 28, 2026

DATE

NOTE: The City of Arcadia reserves the right to use the information provided on this application to verify your residential address and voter registration status. The information provided on this application is for internal use only and confidential information will not be released to the public.

PLEASE SUBMIT YOUR COMPLETED APPLICATION TO: CITY CLERK'S OFFICE  
240 W. HUNTINGTON DRIVE  
ARCADIA, CA 91007

OR

Email us at [CityClerk@ArcadiaCA.gov](mailto:CityClerk@ArcadiaCA.gov)

Questions? Please contact us at (626) 574-5455

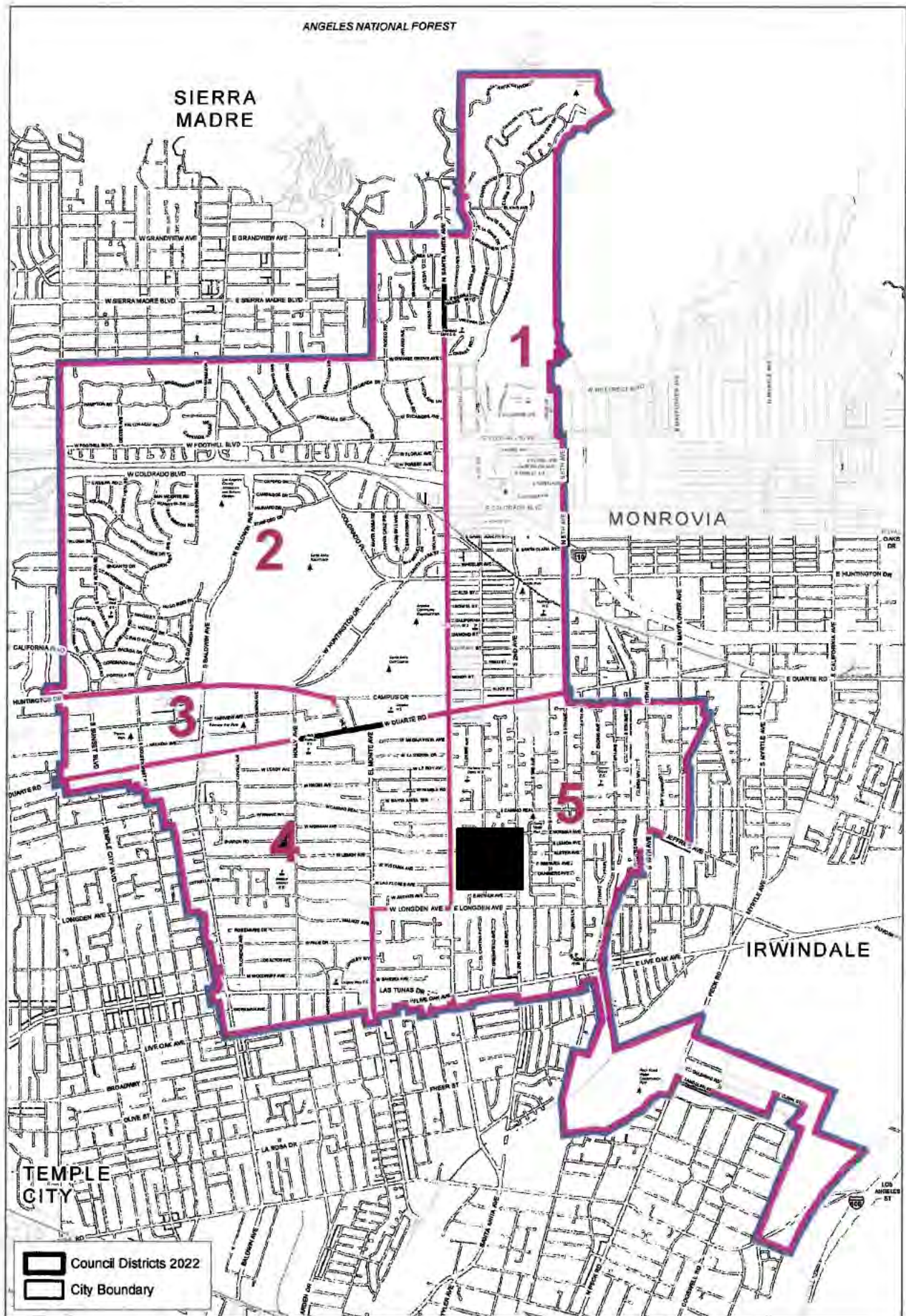

**Council District**  
**City of Arcadia, California**



# City of Arcadia Board/Commission Application

RECEIVED

MAY 4 2026

CITY OF ARCADIA

PLEASE PLACE A CHECK MARK NEXT TO THE BOARD OR COMMISSION FOR WHICH YOU WOULD LIKE TO APPLY (more than one selection may be made):

- |  |   |
|--|---|
| <input type="checkbox"/> Arcadia Beautiful Commission* | <input checked="" type="checkbox"/> Planning Commission             |
| <input type="checkbox"/> Arcadia Museum Commission     | <input checked="" type="checkbox"/> Recreation and Parks Commission |
| <input type="checkbox"/> Human Resources Commission    | <input type="checkbox"/> Senior Citizens Commission                 |
| <input type="checkbox"/> Library Board of Trustees     | <input type="checkbox"/> Arcadia Health Commission                  |

NAME Ricky Lau DATE OF BIRTH (mm/dd/yyyy) [REDACTED]

FIRST LAST

RESIDENTIAL ADDRESS [REDACTED] Arcadia, CA 91006

(Note: Cannot be a mailing address or PO Box)

BUSINESS ADDRESS (HEALTH COMMISSION ONLY) \_\_\_\_\_

I CERTIFY THAT I AM A RESIDENT OF DISTRICT  ONE  TWO  THREE  FOUR  FIVE  
 N/A (Health Commission Only)

PHONE NUMBER [REDACTED] EMAIL ADDRESS [REDACTED]

OCCUPATION IT EMPLOYER Los Angeles County

ARE YOU AN ARCADIA REGISTERED VOTER?  YES  NO

HOW LONG HAVE YOU BEEN A RESIDENT? (If Applicable) 19 years

PLEASE ANSWER THE QUESTIONS BELOW. YOU MAY USE ADDITIONAL SHEETS OF PAPER AS NECESSARY.

**EDUCATION (Include professional or vocational licenses or certificates)**

Bachelor degree of Computer Science

**COMMUNITY INVOLVEMENT (List organization memberships and committee assignments)**

Volunteer of Arcadia Chinese Parents Booster Club in Arcadia Hight School.  
Director of Arcadia Chinese Association.

**PLEASE DESCRIBE ANY BACKGROUND, TRAINING, OR INTERESTS THAT QUALIFY YOU AS AN APPOINTEE**

I am self-motivated and proactive. In my long-time career, I have been working in project study, project analysis, and project management involving IT developments in the government entity.

**WHAT INTERESTS YOU ABOUT THE BOARD/COMMISSION YOU ARE APPLYING FOR?**

Bring my skills and try to improve our community to be in better shape.

ARE YOU AWARE OF THE TIME COMMITMENT NECESSARY TO FULFILL THE OBLIGATIONS OF AN APPOINTMENT TO THIS POSITION?

YES  NO

NOTE: FOR LIBRARY BOARD OF TRUSTEE AND PLANNING COMMISSION APPLICATIONS ONLY  
STATE LAW AND THE CITY CONFLICT OF INTEREST CODE REQUIRES THAT LIBRARY BOARD OF TRUSTEE MEMBERS AND PLANNING COMMISSIONERS FILE A STATEMENT OF ECONOMIC INTERESTS (FORM 700) ANNUALLY AS WELL AS RELATED FORMS WHEN ASSUMING AND LEAVING OFFICE (e.g. sources of income, loans, gifts, investments, interest in real property as required by state law). DO YOU AGREE TO FILE ALL REQUIRED FORMS IN A TIMELY MANNER AS REQUIRED BY THE CITY'S FILING OFFICIAL?

YES  NO

---

**\*ARCADIA BEAUTIFUL APPLICANTS ONLY**

ARE YOU AWARE THAT THE PRIMARY FUNCTION OF THE ARCADIA BEAUTIFUL COMMISSION IS TO ACT AS JUDGES FOR THE COMMISSIONS AWARD PROGRAMS (Spring Home, Holiday Decoration, and Water Smart Hero awards)?

YES  NO

DO YOU HAVE THE ABILITY TO TRAVEL BY CAR DURING THE DAY AND IN THE EVENING FOR THE PURPOSE OF JUDGING?

YES  NO

THE ARCADIA BEAUTIFUL COMMISSION USUALLY HAS FOUR REGULAR MEETINGS EACH YEAR WITH ADDITIONAL MEETINGS AND/OR TIME COMMITMENTS SCHEDULED FOR THE PURPOSE OF CONDUCTING JUDGING FOR THE AWARD PROGRAMS, PARTICIPATING IN A 3-4 HOUR HOLIDAY DECORATION AWARD RECOGNITION EVENT, AND PARTICIPATING IN ARBOR DAY PROGRAMS. ADDITIONALLY, PRELIMINARY JUDGING FOR THE SPRING HOME AND HOLIDAY DECORATION AWARDS IS DONE WITH EACH COMMISSIONER TAKING RESPONSIBILITY FOR A SECTION OF THE CITY AND DRIVING THROUGH THE NEIGHBORHOODS TO SELECT THEIR NOMINATIONS FOR FINAL JUDGING BY THE COMMISSION. ARE YOU ABLE TO FULFILL THIS TIME COMMITMENT?

YES  NO

---

I HEREBY CERTIFY THAT THE FOREGOING INFORMATION IS TRUE AND CORRECT TO THE BEST OF MY KNOWLEDGE.

  
SIGNATURE

5/2/2026

DATE

NOTE: The City of Arcadia reserves the right to use the information provided on this application to verify your residential address and voter registration status. The information provided on this application is for internal use only and confidential information will not be released to the public.

PLEASE SUBMIT YOUR COMPLETED APPLICATION TO: CITY CLERK'S OFFICE  
240 W. HUNTINGTON DRIVE  
ARCADIA, CA 91007

OR

Email us at [CityClerk@ArcadiaCA.gov](mailto:CityClerk@ArcadiaCA.gov)



Questions? Please contact us at (626) 574-5455

SIERRA MADRE

MONROVIA

IRWINDALE

TEMPLE CITY

 Council Districts 2022  
 City Boundary

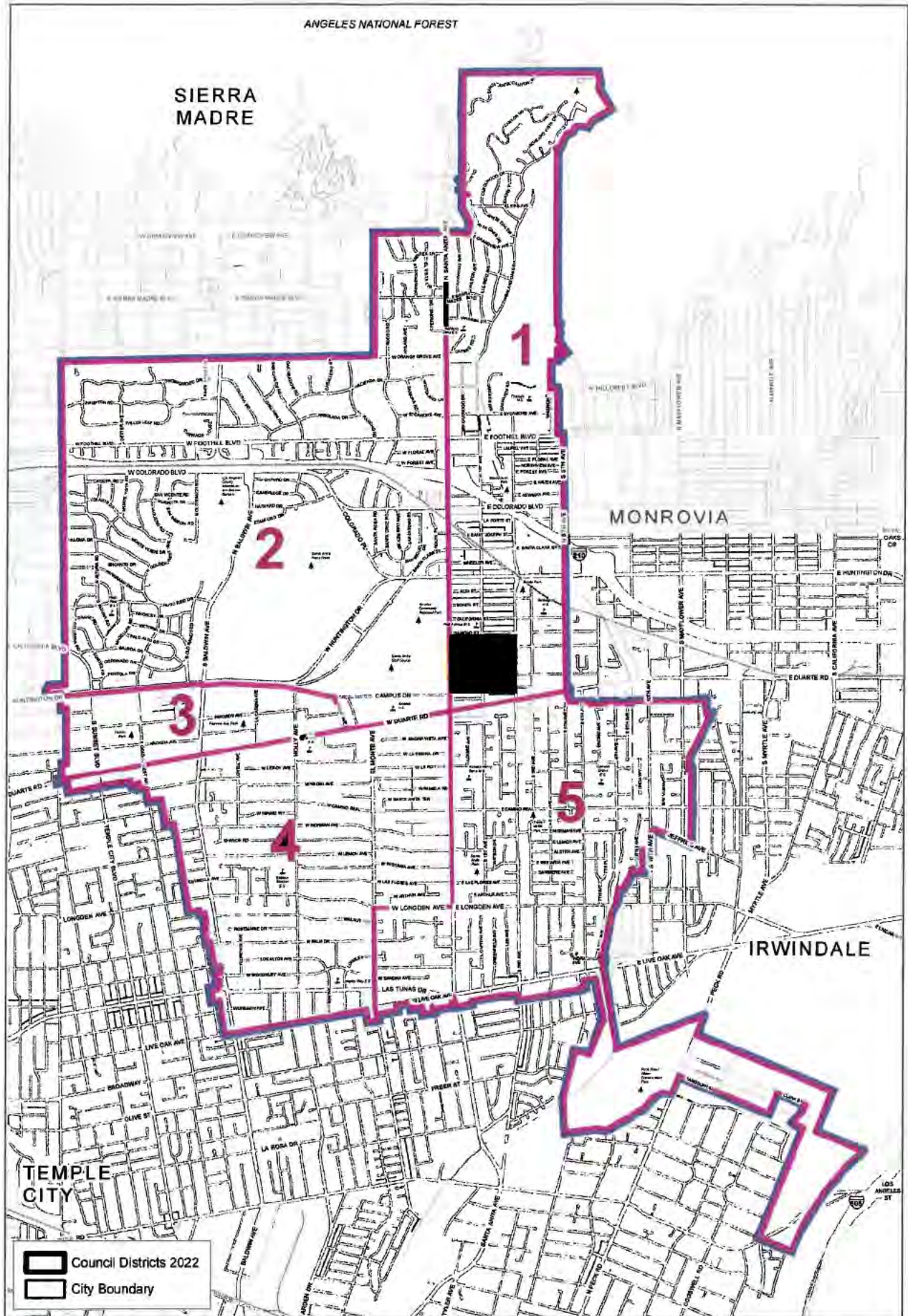

**Council District**  
 City of Arcadia, California



# City of Arcadia Board/Commission Application

RECEIVED

MAY 13 2026

PLEASE PLACE A CHECK MARK NEXT TO THE BOARD OR COMMISSION FOR WHICH YOU WOULD LIKE TO APPLY (more than one selection may be made):

CITY OF ARCADIA  
CITY CLERK

- Arcadia Beautiful Commission\*
- Arcadia Museum Commission
- Human Resources Commission
- Library Board of Trustees
- Planning Commission
- Recreation and Parks Commission
- Senior Citizens Commission
- Arcadia Health Commission

NAME KEVIN MCHUGH DATE OF BIRTH (mm/dd/yyyy) [REDACTED]

FIRST LAST  
RESIDENTIAL ADDRESS [REDACTED]

(Note: Cannot be a mailing address or PO Box)

BUSINESS ADDRESS (HEALTH COMMISSION ONLY) \_\_\_\_\_

I CERTIFY THAT I AM A RESIDENT OF DISTRICT  ONE  TWO  THREE  FOUR  FIVE  
 N/A (Health Commission Only)

PHONE NUMBER [REDACTED] EMAIL ADDRESS [REDACTED]

OCCUPATION Growth Strategist EMPLOYER L.A TURF CLUB d.b.a  
Pari-Mutuel Operation Santa Anita Park

ARE YOU AN ARCADIA REGISTERED VOTER?  YES  NO

HOW LONG HAVE YOU BEEN A RESIDENT? (If Applicable) 10+ years

PLEASE ANSWER THE QUESTIONS BELOW. YOU MAY USE ADDITIONAL SHEETS OF PAPER AS NECESSARY.

EDUCATION (Include professional or vocational licenses or certificates) \*See Attachment

COMMUNITY INVOLVEMENT (List organization memberships and committee assignments) //

PLEASE DESCRIBE ANY BACKGROUND, TRAINING, OR INTERESTS THAT QUALIFY YOU AS AN APPOINTEE //

WHAT INTERESTS YOU ABOUT THE BOARD/COMMISSION YOU ARE APPLYING FOR? //

ARE YOU AWARE OF THE TIME COMMITMENT NECESSARY TO FULFILL THE OBLIGATIONS OF AN APPOINTMENT TO THIS POSITION?

YES  NO

NOTE: FOR LIBRARY BOARD OF TRUSTEE AND PLANNING COMMISSION APPLICATIONS ONLY  
STATE LAW AND THE CITY CONFLICT OF INTEREST CODE REQUIRES THAT LIBRARY BOARD OF TRUSTEE MEMBERS AND PLANNING COMMISSIONERS FILE A STATEMENT OF ECONOMIC INTERESTS (FORM 700) ANNUALLY AS WELL AS RELATED FORMS WHEN ASSUMING AND LEAVING OFFICE (e.g. sources of income, loans, gifts, investments, interest in real property as required by state law). DO YOU AGREE TO FILE ALL REQUIRED FORMS IN A TIMELY MANNER AS REQUIRED BY THE CITY'S FILING OFFICIAL?

YES  NO

---

**\*ARCADIA BEAUTIFUL APPLICANTS ONLY**

ARE YOU AWARE THAT THE PRIMARY FUNCTION OF THE ARCADIA BEAUTIFUL COMMISSION IS TO ACT AS JUDGES FOR THE COMMISSIONS AWARD PROGRAMS (Spring Home, Holiday Decoration, and Water Smart Hero awards)?

YES  NO

DO YOU HAVE THE ABILITY TO TRAVEL BY CAR DURING THE DAY AND IN THE EVENING FOR THE PURPOSE OF JUDGING?

YES  NO

THE ARCADIA BEAUTIFUL COMMISSION USUALLY HAS FOUR REGULAR MEETINGS EACH YEAR WITH ADDITIONAL MEETINGS AND/OR TIME COMMITMENTS SCHEDULED FOR THE PURPOSE OF CONDUCTING JUDGING FOR THE AWARD PROGRAMS, PARTICIPATING IN A 3-4 HOUR HOLIDAY DECORATION AWARD RECOGNITION EVENT, AND PARTICIPATING IN ARBOR DAY PROGRAMS. ADDITIONALLY, PRELIMINARY JUDGING FOR THE SPRING HOME AND HOLIDAY DECORATION AWARDS IS DONE WITH EACH COMMISSIONER TAKING RESPONSIBILITY FOR A SECTION OF THE CITY AND DRIVING THROUGH THE NEIGHBORHOODS TO SELECT THEIR NOMINATIONS FOR FINAL JUDGING BY THE COMMISSION. ARE YOU ABLE TO FULFILL THIS TIME COMMITMENT?

YES  NO

---

I HEREBY CERTIFY THAT THE FOREGOING INFORMATION IS TRUE AND CORRECT TO THE BEST OF MY KNOWLEDGE.

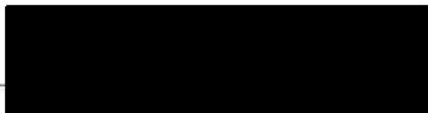

May 6, 2026  
DATE

NOTE: The City of Arcadia reserves the right to use the information provided on this application to verify your residential address and voter registration status. The information provided on this application is for internal use only and confidential information will not be released to the public.

PLEASE SUBMIT YOUR COMPLETED APPLICATION TO: CITY CLERK'S OFFICE  
240 W. HUNTINGTON DRIVE  
ARCADIA, CA 91007

OR

Email us at [CityClerk@ArcadiaCA.gov](mailto:CityClerk@ArcadiaCA.gov)

Questions? Please contact us at (626) 574-5455

***EDUCATION, LICENSES:***

Arcadia Christian - Arcadia Marshall H.S -Pasadena Pasadena City College- Pasadena

Television, Film, Directing, Production, Lighting Certification

CHRB (State of California) License No: 407733 & License No: 411610

CPAT Certification California Fire Fighter Joint Apprenticeship Committee (CFFJAC)

CA DRE License Pre-Requisites Exams Completed (current)

***COMMUNITY INVOLVEMENT (List organization memberships and committee assignments)***

Local 280 Union Guild Member of California (Santa Anita Park) who recently ran for President-Business Agent in December of 2025.

This application is not only to serve on just any role, on any given committee that has a seat they need filled, but specifically the City of Arcadia's Planning Commission. This is the board that I have always wanted to be apart of.

No current affiliation with any clubs or organizations at the moment, however certainly engaged in the safety and well being of my neighbors/neighborhood.

***PLEASE DESCRIBE ANY BACKGROUND, TRAINING, OR INTERESTS THAT QUALIFY YOU AS AN APPOINTEE***

Extensive L.A County wide commercial, municipal, city, and residential construction experience. Familiarity with zoning variances, conditional use permits, and local operational labor perspective.

I have attended past planning meetings where I developed a strong sense of the process, and decided that this is something I can and want to do.

I have seen restaurants and business close that were so directly apart of the fabric of Arcadia to everyone that has grew up and visited here. Not only have I felt the impact, but have listened to the many concerns of others particularly during and after the covid situation.

I grew up here. This city is and will always be near and dear to my heart.

My Grandmother passed away at Arcadia Methodist. She worked at Foothill Middle School. My Grandfather (WW2 vet) passed at the small convalescent home on Huntington Dr & Holly Ave. across from Lucky Baldwins Monument and Gate 3 . They were wonderful people.

**I know Arcadia like the back of my hand.**

**I was apart of the first ever soccer club that represented the city during our AYSO Hawaiian Cup Gold Medal campaign. A ceremonial presentation was presented at City Hall by the late Mayor George Fasching. Just two years later our team again represented the city in the Inaugural Disney Cup Championship Game inside the Rose Bowl- literally just one week after the World Cup Finals took place. Feels apropos with the World Cup returning again this summer.**

***WHAT INTERESTS YOU ABOUT THE BOARD/COMMISSION YOU ARE APPLYING FOR?***

**The ability to make the difficult decisions that have immediate and long-lasting impacts in our business districts and neighborhoods. A platform with like-minded board members that will always strive for the highest level of American Exceptionalism.**

**Applying my team oriented mindset to accomplish great things.**

**Understanding that half hearted efforts + underwhelming involvement = mediocre outcomes.**

**I am looking forward to working with Lisa Flores in some capacity. We will be having an unprecedented 2nd Olympic Equestrian Games at The World Renowned Historical National Treasure that is Santa Anita Park.**

**I am interested in building relationships the IOC and LA28 members to establish vision, long-range goals ensuring that all objectives are reached and expectations are surpassed.**

**Solving problems for proposals such as mixed land use, making determinations, approvals, handling entitlements, and having an input on zoning & historic overlay recommendations are all reasons I would like to be a member of this commission.**

**I am looking forward to reviewing policies-procedures, rendering decisions, and ultimately making recommendations on a wide array of matters which affect the physical development and preservation of our beautiful city.**

SIERRA MADRE

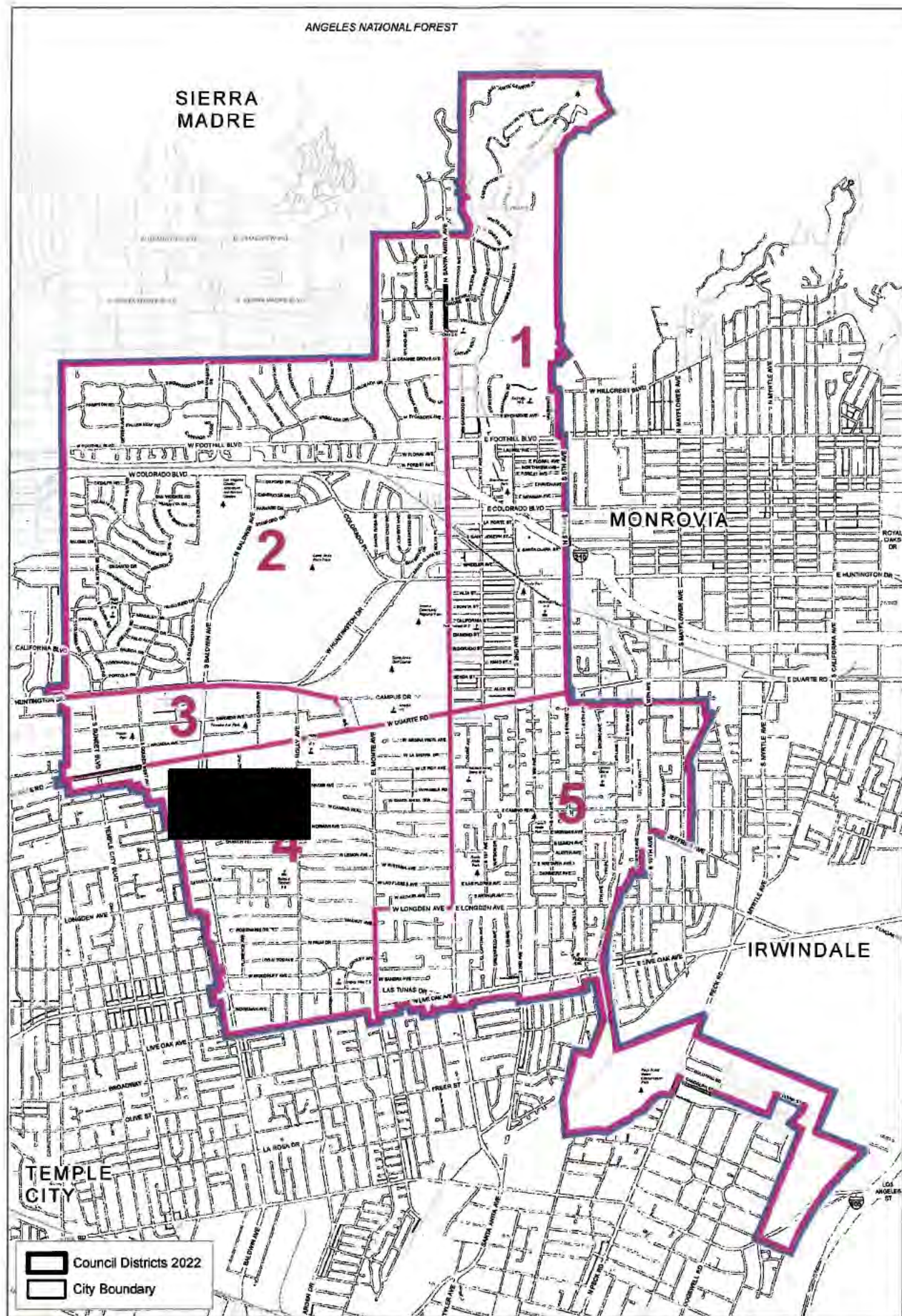

**Council District**  
 City of Arcadia, California



# City of Arcadia Board/Commission Application

RECEIVED

MAY 20 2026

CITY OF ARCADIA  
CITY CLERK

PLEASE PLACE A CHECK MARK NEXT TO THE BOARD OR COMMISSION FOR WHICH YOU WOULD LIKE TO APPLY (more than one selection may be made):

- Arcadia Beautiful Commission\*
- Arcadia Museum Commission
- Human Resources Commission
- Library Board of Trustees
- Planning Commission
- Recreation and Parks Commission
- Senior Citizens Commission
- Arcadia Health Commission

NAME Michael Cham DATE OF BIRTH (mm/dd/yyyy) [REDACTED]

FIRST LAST

RESIDENTIAL ADDRESS [REDACTED] Arcadia CA 91006

(Note: Cannot be a mailing address or PO Box)

BUSINESS ADDRESS (HEALTH COMMISSION ONLY) \_\_\_\_\_

I CERTIFY THAT I AM A RESIDENT OF DISTRICT  ONE  TWO  THREE  FOUR  FIVE  
 N/A (Health Commission Only)

PHONE NUMBER [REDACTED] EMAIL ADDRESS [REDACTED]

OCCUPATION City Planning / Econ Dev. EMPLOYER City of Los Angeles

ARE YOU AN ARCADIA REGISTERED VOTER?  YES  NO

HOW LONG HAVE YOU BEEN A RESIDENT? (If Applicable) 15 years

PLEASE ANSWER THE QUESTIONS BELOW. YOU MAY USE ADDITIONAL SHEETS OF PAPER AS NECESSARY.

**EDUCATION (Include professional or vocational licenses or certificates)**

CA Attorney (Loyola Law School), BA Urban Studies & Planning (UCSD), Certified Planner (APA), Accredited California Economic Developer (CALED), CA Broker's license, Senior Certified HR Professional (SHRM).

**COMMUNITY INVOLVEMENT (List organization memberships and committee assignments)**

I love my current role as Arcadia Beautiful Commissioner but realized this may be the only upcoming year in which a Planning Commissioner will be termed out and ineligible for reappointment. I also am an Elder at a local Christian Church and served as a Board Member of a non-profit organization (Medical Mission Adventures).

**PLEASE DESCRIBE ANY BACKGROUND, TRAINING, OR INTERESTS THAT QUALIFY YOU AS AN APPOINTEE**

I have over 25 years of professional experience in local government, specifically in the fields of City Planning, Real Estate, and Economic Development. I have expertise directly applicable to Planning Commission, having served as staff of Design Review Boards, an applicant, and community representative.

**WHAT INTERESTS YOU ABOUT THE BOARD/COMMISSION YOU ARE APPLYING FOR?**

Born and raised in the SGV and an Arcadia resident for 15 years, I have a deep personal connection to this City and hope to apply my professional experience to public service. I am committed to faithfully implementing the City Charter and Zoning Code, reviewing each application with fairness and respect for individual property owners and applicants, and making decisions that build upon existing neighborhood character and enhance Arcadia's overall quality of life.

ARE YOU AWARE OF THE TIME COMMITMENT NECESSARY TO FULFILL THE OBLIGATIONS OF AN APPOINTMENT TO THIS POSITION?

YES  NO

NOTE: FOR LIBRARY BOARD OF TRUSTEE AND PLANNING COMMISSION APPLICATIONS ONLY  
STATE LAW AND THE CITY CONFLICT OF INTEREST CODE REQUIRES THAT LIBRARY BOARD OF TRUSTEE MEMBERS AND PLANNING COMMISSIONERS FILE A STATEMENT OF ECONOMIC INTERESTS (FORM 700) ANNUALLY AS WELL AS RELATED FORMS WHEN ASSUMING AND LEAVING OFFICE (e.g. sources of income, loans, gifts, investments, interest in real property as required by state law). DO YOU AGREE TO FILE ALL REQUIRED FORMS IN A TIMELY MANNER AS REQUIRED BY THE CITY'S FILING OFFICIAL?

YES  NO

---

**\*ARCADIA BEAUTIFUL APPLICANTS ONLY**

ARE YOU AWARE THAT THE PRIMARY FUNCTION OF THE ARCADIA BEAUTIFUL COMMISSION IS TO ACT AS JUDGES FOR THE COMMISSIONS AWARD PROGRAMS (Spring Home, Holiday Decoration, and Water Smart Hero awards)?

YES  NO

DO YOU HAVE THE ABILITY TO TRAVEL BY CAR DURING THE DAY AND IN THE EVENING FOR THE PURPOSE OF JUDGING?

YES  NO

THE ARCADIA BEAUTIFUL COMMISSION USUALLY HAS FOUR REGULAR MEETINGS EACH YEAR WITH ADDITIONAL MEETINGS AND/OR TIME COMMITMENTS SCHEDULED FOR THE PURPOSE OF CONDUCTING JUDGING FOR THE AWARD PROGRAMS, PARTICIPATING IN A 3-4 HOUR HOLIDAY DECORATION AWARD RECOGNITION EVENT, AND PARTICIPATING IN ARBOR DAY PROGRAMS. ADDITIONALLY, PRELIMINARY JUDGING FOR THE SPRING HOME AND HOLIDAY DECORATION AWARDS IS DONE WITH EACH COMMISSIONER TAKING RESPONSIBILITY FOR A SECTION OF THE CITY AND DRIVING THROUGH THE NEIGHBORHOODS TO SELECT THEIR NOMINATIONS FOR FINAL JUDGING BY THE COMMISSION. ARE YOU ABLE TO FULFILL THIS TIME COMMITMENT?

YES  NO

---

I HEREBY CERTIFY THAT THE FOREGOING INFORMATION IS TRUE AND CORRECT TO THE BEST OF MY KNOWLEDGE.



SIGNATURE

05/20/2026

DATE

NOTE: The City of Arcadia reserves the right to use the information provided on this application to verify your residential address and voter registration status. The information provided on this application is for internal use only and confidential information will not be released to the public.

PLEASE SUBMIT YOUR COMPLETED APPLICATION TO: CITY CLERK'S OFFICE  
240 W. HUNTINGTON DRIVE  
ARCADIA, CA 91007

OR

Email us at [CityClerk@ArcadiaCA.gov](mailto:CityClerk@ArcadiaCA.gov)

Questions? Please contact us at (626) 574-5455

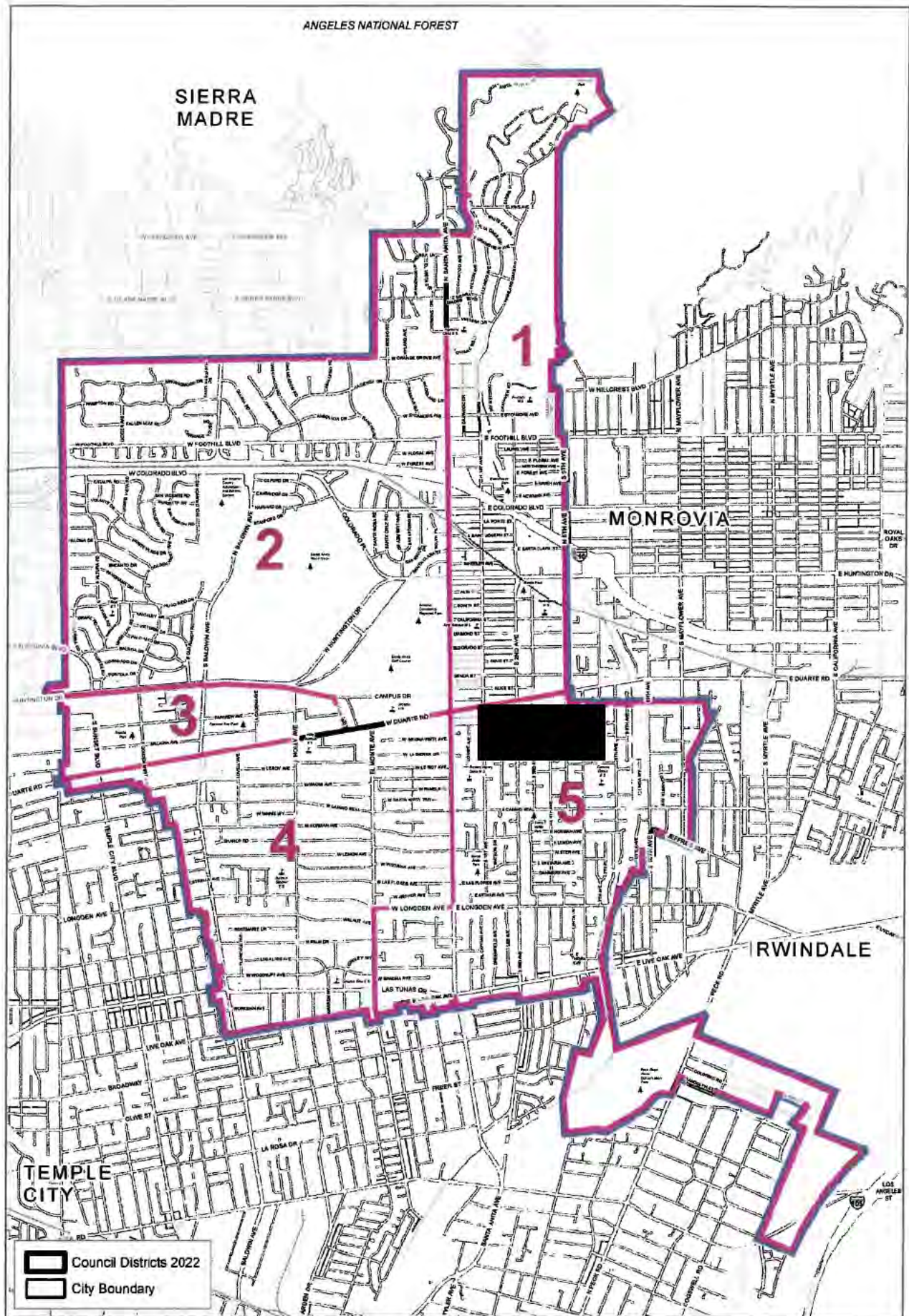

SIERRA MADRE



TEMPLE CITY

MONROVIA

RWINDALE

 Council Districts 2022  
 City Boundary



**Council District**  
 City of Arcadia, California



# City of Arcadia Board/Commission Application

MAY 26 2026

CITY OF ARCADIA  
CITY CLERK

PLEASE PLACE A CHECK MARK NEXT TO THE BOARD OR COMMISSION FOR WHICH YOU WOULD LIKE TO APPLY (more than one selection may be made):

- Arcadia Beautiful Commission\*
- Arcadia Museum Commission
- Human Resources Commission
- Library Board of Trustees

- Planning Commission
- Recreation and Parks Commission
- Senior Citizens Commission
- Arcadia Health Commission

NAME COLIN LEUNG DATE OF BIRTH (mm/dd/yyyy) [REDACTED]  
FIRST LAST

RESIDENTIAL ADDRESS [REDACTED] ARCADIA, CA 91007  
(Note: Cannot be a mailing address or PO Box)

BUSINESS ADDRESS (HEALTH COMMISSION ONLY) \_\_\_\_\_

I CERTIFY THAT I AM A RESIDENT OF DISTRICT  ONE  TWO  THREE  FOUR  FIVE  
 N/A (Health Commission Only)

PHONE NUMBER [REDACTED] EMAIL ADDRESS [REDACTED]

OCCUPATION STRUCTURAL ENGINEER EMPLOYER CITY OF GLENDALE

ARE YOU AN ARCADIA REGISTERED VOTER?  YES  NO

HOW LONG HAVE YOU BEEN A RESIDENT? (if Applicable) > 25 YRS

PLEASE ANSWER THE QUESTIONS BELOW. YOU MAY USE ADDITIONAL SHEETS OF PAPER AS NECESSARY.

**EDUCATION (Include professional or vocational licenses or certificates)**

- MS STRUCTURAL ENGINEERING
  - CALIFORNIA LICENSED PROFESSIONAL ENGINEER AND STRUCTURAL ENGINEER
  - CALIFORNIA CERTIFIED BUILDING CODE SPECIALIST • CERTIFIED ACCESSIBLE SPECIALIST
- COMMUNITY INVOLVEMENT (List organization memberships and committee assignments)  
 ARCADIA HIGH SCHOOL - ORCHESTRA BENEFIT DINNER CO-CHAIR 2024 ~ 2026  
 INTERNATIONAL CODE COUNCIL, CALIFORNIA BUILDING OFFICIAL ~ MEMBER, EVENT COORDINATOR

PLEASE DESCRIBE ANY BACKGROUND, TRAINING, OR INTERESTS THAT QUALIFY YOU AS AN APPOINTEE  
 I'VE BEEN LICENSED STRUCTURAL ENGINEER INVOLVES IN NUMEROUS DEVELOPMENT IN DIFFERENT CITIES INCLUDES LOS ANGELES, PASADENA, CULVER CITY, BURBANK, PALM DALE, ... ETC  
 I, AS A BUILDING CODE SPECIALIST, WORK CLOSELY WITH PLANNING DEPARTMENT IN GLENDALE EVERYDAY REGARDING DESIGN REVIEW, ZONING, ACCESSIBILITY ISSUES.

WHAT INTERESTS YOU ABOUT THE BOARD/COMMISSION YOU ARE APPLYING FOR?  
 HAVING BEEN LIVING IN ARCADIA FOR OVER 25 YRS, I'VE ALWAYS WANT TO BE PART OF THE TEAM WHO HELPS ARCADIA BECOMING ONE OF THE BEST CITIES IN CALIFORNIA.

ARE YOU AWARE OF THE TIME COMMITMENT NECESSARY TO FULFILL THE OBLIGATIONS OF AN APPOINTMENT TO THIS POSITION?

YES  NO

NOTE: FOR LIBRARY BOARD OF TRUSTEE AND PLANNING COMMISSION APPLICATIONS ONLY  
STATE LAW AND THE CITY CONFLICT OF INTEREST CODE REQUIRES THAT LIBRARY BOARD OF TRUSTEE MEMBERS AND PLANNING COMMISSIONERS FILE A STATEMENT OF ECONOMIC INTERESTS (FORM 700) ANNUALLY AS WELL AS RELATED FORMS WHEN ASSUMING AND LEAVING OFFICE (e.g. sources of income, loans, gifts, investments, interest in real property as required by state law). DO YOU AGREE TO FILE ALL REQUIRED FORMS IN A TIMELY MANNER AS REQUIRED BY THE CITY'S FILING OFFICIAL?

YES  NO

---

**\*ARCADIA BEAUTIFUL APPLICANTS ONLY**

ARE YOU AWARE THAT THE PRIMARY FUNCTION OF THE ARCADIA BEAUTIFUL COMMISSION IS TO ACT AS JUDGES FOR THE COMMISSIONS AWARD PROGRAMS (Spring Home, Holiday Decoration, and Water Smart Hero awards)?

YES  NO

DO YOU HAVE THE ABILITY TO TRAVEL BY CAR DURING THE DAY AND IN THE EVENING FOR THE PURPOSE OF JUDGING?

YES  NO

THE ARCADIA BEAUTIFUL COMMISSION USUALLY HAS FOUR REGULAR MEETINGS EACH YEAR WITH ADDITIONAL MEETINGS AND/OR TIME COMMITMENTS SCHEDULED FOR THE PURPOSE OF CONDUCTING JUDGING FOR THE AWARD PROGRAMS, PARTICIPATING IN A 3-4 HOUR HOLIDAY DECORATION AWARD RECOGNITION EVENT, AND PARTICIPATING IN ARBOR DAY PROGRAMS. ADDITIONALLY, PRELIMINARY JUDGING FOR THE SPRING HOME AND HOLIDAY DECORATION AWARDS IS DONE WITH EACH COMMISSIONER TAKING RESPONSIBILITY FOR A SECTION OF THE CITY AND DRIVING THROUGH THE NEIGHBORHOODS TO SELECT THEIR NOMINATIONS FOR FINAL JUDGING BY THE COMMISSION. ARE YOU ABLE TO FULFILL THIS TIME COMMITMENT?

YES  NO

---

I HEREBY CERTIFY THAT THE FOREGOING INFORMATION IS TRUE AND CORRECT TO THE BEST OF MY KNOWLEDGE.



SIGNATURE

05/22/2020

DATE

NOTE: The City of Arcadia reserves the right to use the information provided on this application to verify your residential address and voter registration status. The information provided on this application is for internal use only and confidential information will not be released to the public.

PLEASE SUBMIT YOUR COMPLETED APPLICATION TO: CITY CLERK'S OFFICE  
240 W. HUNTINGTON DRIVE  
ARCADIA, CA 91007

OR

Email us at [CityClerk@ArcadiaCA.gov](mailto:CityClerk@ArcadiaCA.gov)

Questions? Please contact us at (626) 574-5455

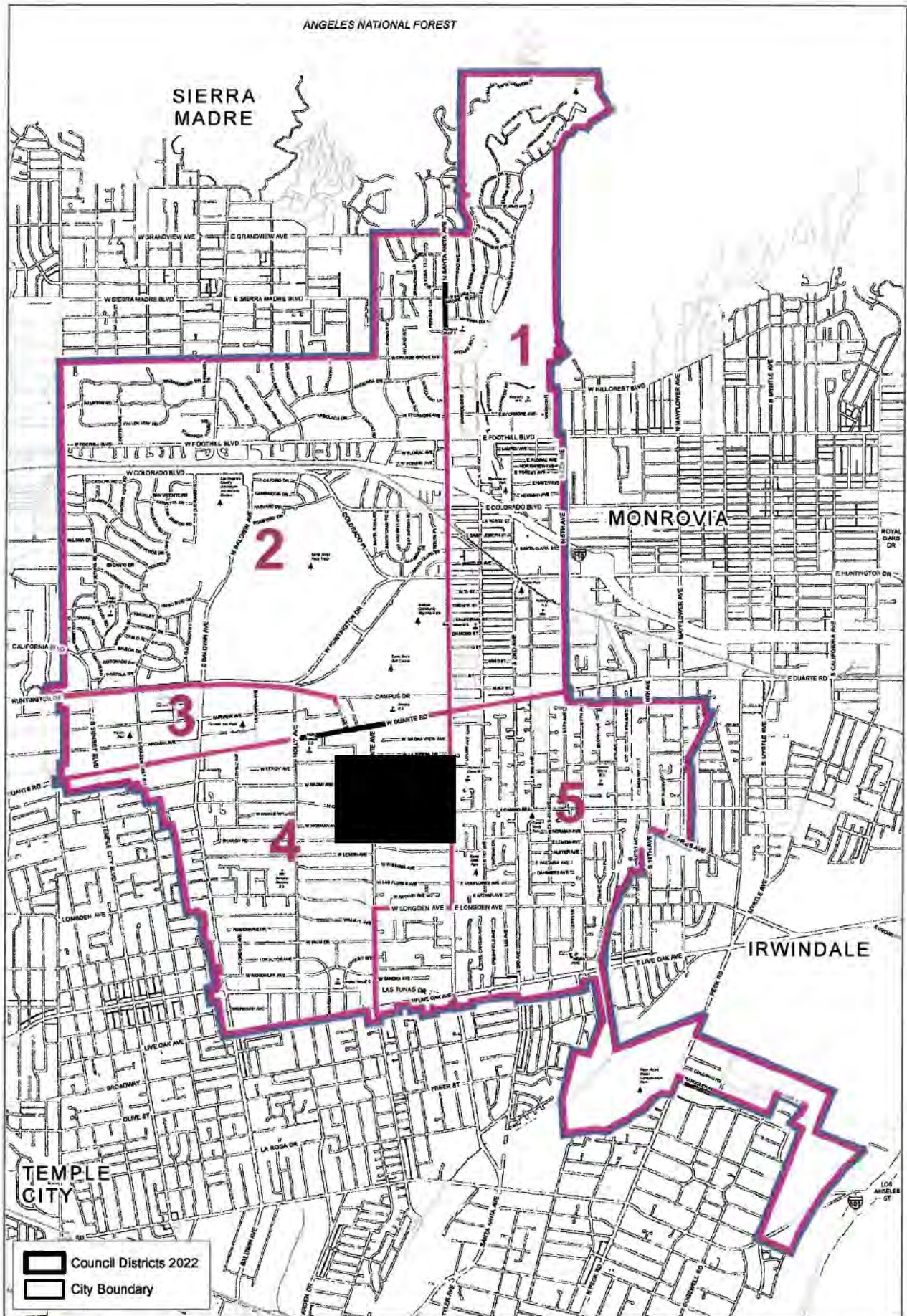

**Council District**  
City of Arcadia, California



RECEIVED

# City of Arcadia Board/Commission Application

MAY 26 2026

PLEASE PLACE A CHECK MARK NEXT TO THE BOARD OR COMMISSION FOR WHICH YOU WOULD LIKE TO APPLY. (more than one selection may be made):

CITY OF ARCADIA  
OFFICE

- |  |   |
|--|---|
| <input type="checkbox"/> Arcadia Beautiful Commission* | <input checked="" type="checkbox"/> Planning Commission             |
| <input type="checkbox"/> Arcadia Museum Commission     | <input checked="" type="checkbox"/> Recreation and Parks Commission |
| <input type="checkbox"/> Human Resources Commission    | <input type="checkbox"/> Senior Citizens Commission                 |
| <input type="checkbox"/> Library Board of Trustees     | <input type="checkbox"/> Arcadia Health Commission                  |

NAME Cris Arzate DATE OF BIRTH (mm/dd/yyyy) [REDACTED]

FIRST LAST

RESIDENTIAL ADDRESS [REDACTED] Arcadia Ca 91006

(Note: Cannot be a mailing address or PO Box)

BUSINESS ADDRESS (HEALTH COMMISSION ONLY) \_\_\_\_\_

I CERTIFY THAT I AM A RESIDENT OF DISTRICT  ONE  TWO  THREE  FOUR  FIVE  
 N/A (Health Commission Only)

PHONE NUMBER [REDACTED]

EMAIL ADDRESS [REDACTED]

OCCUPATION Affordable Housing/Community Affairs

EMPLOYER Housing Authority of the City of Los Angeles

ARE YOU AN ARCADIA REGISTERED VOTER?  YES  NO

HOW LONG HAVE YOU BEEN A RESIDENT? (If Applicable) 5

PLEASE ANSWER THE QUESTIONS BELOW YOU MAY USE ADDITIONAL SHEETS OF PAPER AS NECESSARY

**EDUCATION (Include professional or vocational licenses or certificates)**

BA U.C. Berkeley, MRED Georgetown University, Coro Fellow in Public Affairs, Harvard Graduate School of Education Management Development (Certificate), U.S.C. Ross Program in Real Estate Development and Finance (Certificate)

**COMMUNITY INVOLVEMENT (List organization memberships and committee assignments)**

Commissioner City of Arcadia, Senior Citizens Commission, Commissioner California Student Aid Commission, Board President California Structural Pest Control Board, Chair Los Angeles Unified School District Human Relations Commission.

**PLEASE DESCRIBE ANY BACKGROUND, TRAINING, OR INTERESTS THAT QUALIFY YOU AS AN APPOINTEE**

Twenty five years of experience in state and local governing boards with budgets ranging from \$10 million to \$1.5 Billion. Career in real estate (realtor, affordable housing and community affairs), extensive experience in public policy and government relations. Served as Executive Director of multiple non profits (youth and public safety) Raised over \$20 million in public, private individual and foundation funds for public and private projects.

**WHAT INTERESTS YOU ABOUT THE BOARD/COMMISSION YOU ARE APPLYING FOR?**

As a resident of Arcadia, I want to use my time, experience and resources to improve the quality of life for our residents and businesses. June is my last month on the Senior Citizens Commission, and it has provided a great deal of insight to the City and its residents and the staff that make Arcadia function at a very high level. My experience in real estate, economic development, public safety, digital equity and youth development serves as a lens that few bring to the Planning Commission. This holistic view, passion and vision enables me to provide thoughtful and insightful

ARE YOU AWARE OF THE TIME COMMITMENT NECESSARY TO FULFILL THE OBLIGATIONS OF AN APPOINTMENT TO THIS POSITION?

YES  NO

NOTE FOR LIBRARY BOARD OF TRUSTEE AND PLANNING COMMISSION APPLICATIONS ONLY  
STATE LAW AND THE CITY CONFLICT OF INTEREST CODE REQUIRES THAT LIBRARY BOARD OF TRUSTEE MEMBERS AND PLANNING COMMISSIONERS FILE A STATEMENT OF ECONOMIC INTERESTS (FORM 700) ANNUALLY AS WELL AS RELATED FORMS WHEN ASSUMING AND LEAVING OFFICE (e.g. sources of income, loans, gifts, investments, interest in real property as required by state law). DO YOU AGREE TO FILE ALL REQUIRED FORMS IN A TIMELY MANNER AS REQUIRED BY THE CITY'S FILING OFFICIAL?

YES  NO

**\*ARCADIA BEAUTIFUL APPLICANTS ONLY**

ARE YOU AWARE THAT THE PRIMARY FUNCTION OF THE ARCADIA BEAUTIFUL COMMISSION IS TO ACT AS JUDGES FOR THE COMMISSIONS AWARD PROGRAMS (Spring Home, Holiday Decoration, and Water Smart Hero awards)?

YES  NO

DO YOU HAVE THE ABILITY TO TRAVEL BY CAR DURING THE DAY AND IN THE EVENING FOR THE PURPOSE OF JUDGING?

YES  NO

THE ARCADIA BEAUTIFUL COMMISSION USUALLY HAS FOUR REGULAR MEETINGS EACH YEAR WITH ADDITIONAL MEETINGS AND/OR TIME COMMITMENTS SCHEDULED FOR THE PURPOSE OF CONDUCTING JUDGING FOR THE AWARD PROGRAMS, PARTICIPATING IN A 3-4 HOUR HOLIDAY DECORATION AWARD RECOGNITION EVENT, AND PARTICIPATING IN ARBOR DAY PROGRAMS. ADDITIONALLY, PRELIMINARY JUDGING FOR THE SPRING HOME AND HOLIDAY DECORATION AWARDS IS DONE WITH EACH COMMISSIONER TAKING RESPONSIBILITY FOR A SECTION OF THE CITY AND DRIVING THROUGH THE NEIGHBORHOODS TO SELECT THEIR NOMINATIONS FOR FINAL JUDGING BY THE COMMISSION. ARE YOU ABLE TO FULFILL THIS TIME COMMITMENT?

YES  NO

I HEREBY CERTIFY THAT THE FOREGOING INFORMATION IS TRUE AND CORRECT TO THE BEST OF MY KNOWLEDGE.



SIGNATURE

5/22/24  
DATE

NOTE: The City of Arcadia reserves the right to use the information provided on this application to verify your residential address and voter registration status. The information provided on this application is for internal use only and confidential information will not be released to the public.

PLEASE SUBMIT YOUR COMPLETED APPLICATION TO: CITY CLERK'S OFFICE  
240 W. HUNTINGTON DRIVE  
ARCADIA, CA 91007

OR

Email us at [CityClerk@ArcadiaCA.gov](mailto:CityClerk@ArcadiaCA.gov)

Questions? Please contact us at (626) 574-5455

# *Cris Arzate*

[REDACTED] Arcadia, Ca 91006  
[REDACTED]

---

## **PROFESSIONAL EXPERIENCE**

## **POSITION**

### **Housing Authority of the City of Los Angeles**

### **Deputy Assistant Director**

January 2021 - Present

- Direct the strategy, management, assessment and resource development for all resident services for 18,250 residents in 6,120 units within all 12 public housing developments in our portfolio.
- Created and direct the Digital Equity Master Plan for HACLA, including policy analysis, advocacy, resource development to renovate 11 computer labs, and compliance with various private and public funding.
- Budget Management: Annually plan, administer and report expenditure of \$4.5 million in public funds, to service providers, consultants, and operations for delivery of services
- Partnership Development: Build new and manage existing relationships with external community-based organizations, public parties and private sector interests.
- Contract Management: Manage legal staff responsible for generating and amending contracts for our 120 different service providers. Generate and administer RFP's for service providers, contractors, and other professional services.
- Resource Development: Identify, solicit and secure resources for families, digital equity programs, scholarships and facilities. Supervise the reporting for publicly funded grants and communicate with private sector donors.
- Change Management: Counsel and support the transition of programs, budgets, staff, and facilities within HACLA and between HACLA and its philanthropic arm Build Hope Inc.
- Community Engagement: Collaborate with Resident Advisory Councils (RACs), and local stakeholders to address resident concerns, represent their interests, and cultivate an improved living environment.
- Capital Improvement: Project manage and raise capital for computer lab renovations at public housing sites. Supervision of architect, contractor, in collaboration with legal for licensing agreement to renovate. Identify, solicit and secure funding for equipment, staff and training for digital equity programs within the facilities.
- Data Management: Developed online reporting system for all resident service providers (licensees). The platform maintains records to assess effectiveness and inform improvements.

### **TWELVE Co.: A Public Affairs Consultancy**

### **Principal**

June 2015 - Present

- Provide executive consulting services to non-profit organizations, foundations, affordable housing developers, and small businesses.
- Organize advocacy campaigns throughout California to support the advancement of public policy in education, affordable housing, technology, and economic development.
- Secured \$6 million for affordable housing developers on complex public finance opportunities.
- Provide professional development to constituent groups: board members, staff, and volunteers.

### **Variety Boys and Girls Club**

### **Executive Director**

July 2011 – June 2015

- Identified, solicited, authored proposals and successfully raised over \$5,000,000 in foundation, corporate, and individual funds to operate the organization.
- Diversified board of directors from 12 to 25 to change the culture, staff and programming to college readiness.
- Developed the organizations first 5-year strategic plan, updated HR policies and procedures, employee handbook, and orientations.
- Administered the operations of two sites of the organization with a 25-member board of directors and a staff of 35.
- Led annual fundraising events including annual gala, golf tournament, giving campaign.
- Solicited and organized an annual scholarship program that annually awarded over \$100,000.

**One-Economy Corporation**

**Director - California**

January 2008 to July 2011

- Directed the strategy and implementation a statewide \$2 million, technology-based community development grant funded program in 10 rural and urban California communities.
- Cultivated, evaluated and selected public-private partnerships throughout California to connect 10,000+ low-income housing units to the internet, secured over \$1 million in technology resources, employed 125 youth and adults, acquired hardware and created content tailored to the specific community.
- Directed staff of 8 to implement resources and programmatic activities.
- Chaired 3 regional executive level community advisory boards and authored 10 technology based Digital Inclusion plans for 10 low-income urban and rural communities in California.

**Southern New Hampshire University**

**Consultant**

July 2006 to March 2008

- Created the West Coast Center of the Southern New Hampshire University (SNHU), Master of Science in Community Economic Development.
- Developed marketing and strategic partnership strategies to introduce SNHU to Southern California stakeholders.
- Identified, evaluated, and admitted professionals into the program with a 95% retention rate upon graduation.
- Recruited local professors to administer the inaugural class and their respective coursework.
- Oriented students on financial aid programs, on-line assistance, and programs expectations.

**Los Angeles Trade-Technical Community College**

**Advisor to the President / Director**

August 2001 – July 2006

- Secured and administered \$1.8 million in grants: small business, workforce development, and technology.
- Directed the Non-Credit Department and established over 15 community based and institutional partnerships to deliver free entry level courses throughout South L.A., Pico Union, MacArthur Park, Boyle Heights, and East Los Angeles
- Acted on behalf of the President on external relations and institutional advancement as a public relations liaison for the college
- Drafted all external and internal LATTC publications on behalf of the President.
- Identified, hired, and supervised approximately 40 faculty to implement state and federally funded courses.
- Created the LATTC Resource Development Office.

**EDUCATION, PROFESSIONAL DEVELOPMENT, LICENSE & APPOINTMENTS**

**Georgetown University**

Masters, Real Estate Development

**University of California, Berkeley**

Bachelor's, Political Science

**Harvard Graduate School of Education**

Management Development Program

**University of Southern California**

Real Estate Finance & Development

**Coro Fellows Program in Public Affairs**

Fellowship

**Annenberg Foundation**

Alchemy PLUS Leadership Series

**The Center for Non-Profit Management**

Non-Profit Leadership Dev. Program

**California Department of Real Estate**

Real Estate Salesperson

**APPOINTMENTS**

**California Student Aid Commission**

Commissioner (Secretary)

**California Dept. of Consumer Affairs**

Board Member (President)

**City of Arcadia: Senior Citizens Commission**

Commissioner

**L.A.U.S.D: Human Relations Commission**

Commissioner (Chair)

SIERRA MADRE

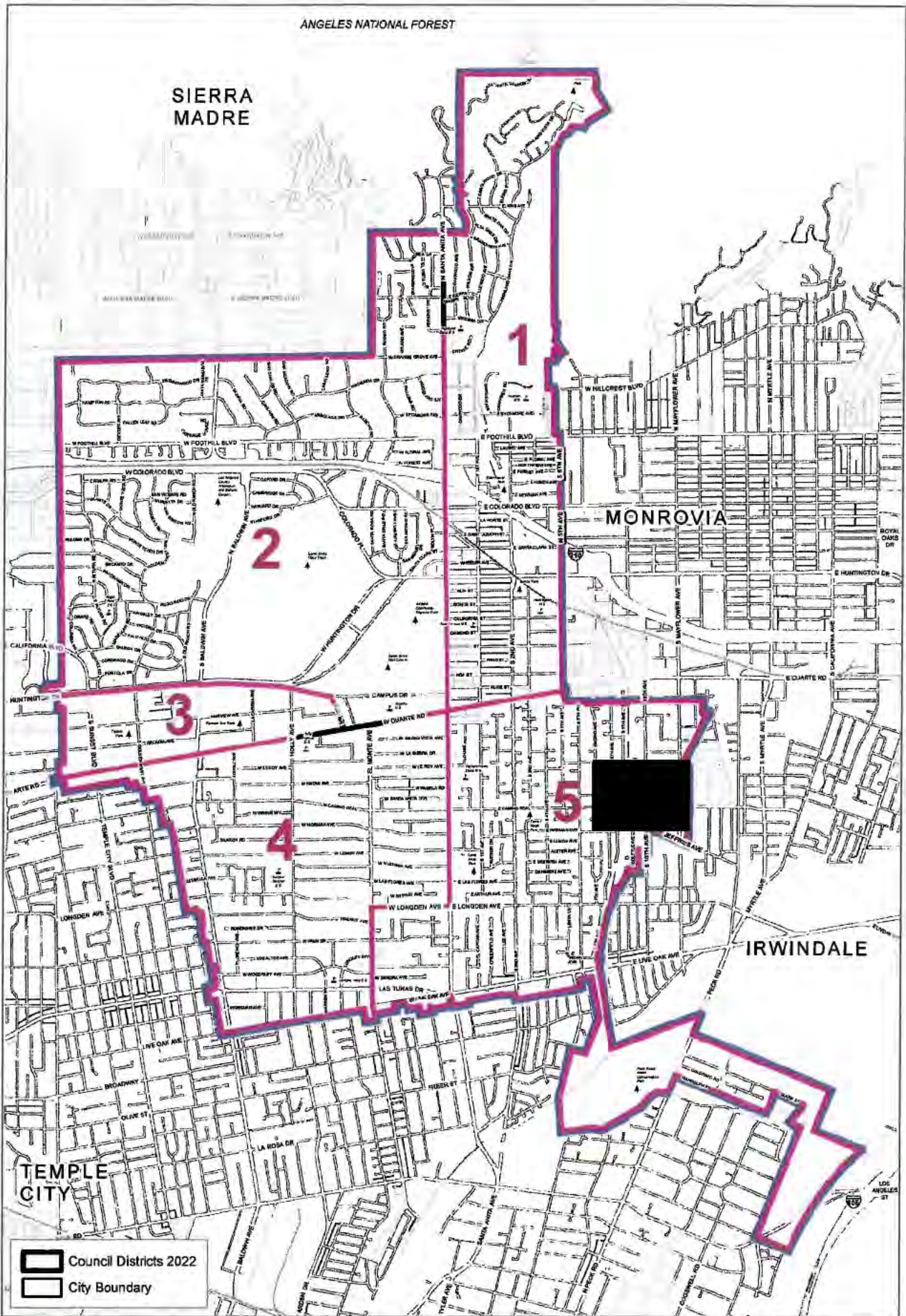

**Council District**  
*City of Arcadia, California*



# City of Arcadia Board/Commission Application

PLEASE PLACE A CHECK MARK NEXT TO THE BOARD OR COMMISSION FOR WHICH YOU WOULD LIKE TO APPLY (more than one selection may be made):

- |  |  |
|--|--|
| <input type="checkbox"/> Arcadia Beautiful Commission* | <input checked="" type="checkbox"/> Planning Commission  |
| <input type="checkbox"/> Arcadia Museum Commission     | <input type="checkbox"/> Recreation and Parks Commission |
| <input type="checkbox"/> Human Resources Commission    | <input type="checkbox"/> Senior Citizens Commission      |
| <input type="checkbox"/> Library Board of Trustees     | <input type="checkbox"/> Arcadia Health Commission       |

NAME Kenneth Chan DATE OF BIRTH (mm/dd/yyyy) [REDACTED]

FIRST LAST

RESIDENTIAL ADDRESS [REDACTED]

(Note: Cannot be a mailing address or PO Box)

BUSINESS ADDRESS (HEALTH COMMISSION ONLY) \_\_\_\_\_

I CERTIFY THAT I AM A RESIDENT OF DISTRICT  ONE  TWO  THREE  FOUR  FIVE  
 N/A (Health Commission Only)

PHONE NUMBER [REDACTED] EMAIL ADDRESS [REDACTED]

OCCUPATION retired EMPLOYER \_\_\_\_\_

ARE YOU AN ARCADIA REGISTERED VOTER?  YES  NO

HOW LONG HAVE YOU BEEN A RESIDENT? (If Applicable) 18 years

PLEASE ANSWER THE QUESTIONS BELOW. YOU MAY USE ADDITIONAL SHEETS OF PAPER AS NECESSARY.

EDUCATION (Include professional or vocational licenses or certificates)

Planning Commission B/S BUSINESS/MARKETING WOODBURY UNIVERSITY

COMMUNITY INVOLVEMENT (List organization memberships and committee assignments)

Planning Commission PAST MEMBER  
CHARTER MEMBER ARCADIA ROTARY

PLEASE DESCRIBE ANY BACKGROUND, TRAINING, OR INTERESTS THAT QUALIFY YOU AS AN APPOINTEE

Planning Commission PAST MEMBER ARCADIA  
PAST MEMBER ALHAMBRA PLANNING COMMISSION  
PAST MEMBER ALHAMBRA REDEVELOPMENT COMMITTEE/MAIN STREET  
PAST MEMBER COUNCIL DISTRICT 1 CRA

WHAT INTERESTS YOU ABOUT THE BOARD/COMMISSION YOU ARE APPLYING FOR?

Planning Commission

ARE YOU AWARE OF THE TIME COMMITMENT NECESSARY TO FULFILL THE OBLIGATIONS OF AN APPOINTMENT TO THIS POSITION?

YES  NO

NOTE: FOR LIBRARY BOARD OF TRUSTEE AND PLANNING COMMISSION APPLICATIONS ONLY  
STATE LAW AND THE CITY CONFLICT OF INTEREST CODE REQUIRES THAT LIBRARY BOARD OF TRUSTEE MEMBERS AND PLANNING COMMISSIONERS FILE A STATEMENT OF ECONOMIC INTERESTS (FORM 700) ANNUALLY AS WELL AS RELATED FORMS WHEN ASSUMING AND LEAVING OFFICE (e.g. sources of income, loans, gifts, investments, interest in real property as required by state law). DO YOU AGREE TO FILE ALL REQUIRED FORMS IN A TIMELY MANNER AS REQUIRED BY THE CITY'S FILING OFFICIAL?

YES  NO

---

**\*ARCADIA BEAUTIFUL APPLICANTS ONLY**

ARE YOU AWARE THAT THE PRIMARY FUNCTION OF THE ARCADIA BEAUTIFUL COMMISSION IS TO ACT AS JUDGES FOR THE COMMISSIONS AWARD PROGRAMS (Spring Home, Holiday Decoration, and Water Smart Hero awards)?

YES  NO

DO YOU HAVE THE ABILITY TO TRAVEL BY CAR DURING THE DAY AND IN THE EVENING FOR THE PURPOSE OF JUDGING?

YES  NO

THE ARCADIA BEAUTIFUL COMMISSION USUALLY HAS FOUR REGULAR MEETINGS EACH YEAR WITH ADDITIONAL MEETINGS AND/OR TIME COMMITMENTS SCHEDULED FOR THE PURPOSE OF CONDUCTING JUDGING FOR THE AWARD PROGRAMS, PARTICIPATING IN A 3-4 HOUR HOLIDAY DECORATION AWARD RECOGNITION EVENT, AND PARTICIPATING IN ARBOR DAY PROGRAMS. ADDITIONALLY, PRELIMINARY JUDGING FOR THE SPRING HOME AND HOLIDAY DECORATION AWARDS IS DONE WITH EACH COMMISSIONER TAKING RESPONSIBILITY FOR A SECTION OF THE CITY AND DRIVING THROUGH THE NEIGHBORHOODS TO SELECT THEIR NOMINATIONS FOR FINAL JUDGING BY THE COMMISSION. ARE YOU ABLE TO FULFILL THIS TIME COMMITMENT?

YES  NO

---

I HEREBY CERTIFY THAT THE FOREGOING INFORMATION IS TRUE AND CORRECT TO THE BEST OF MY KNOWLEDGE.

Kenneth L Chan



SIGNATURE

12062025

DATE

NOTE: The City of Arcadia reserves the right to use the information provided on this application to verify your residential address and voter registration status. The information provided on this application is for internal use only and confidential information will not be released to the public.

PLEASE SUBMIT YOUR COMPLETED APPLICATION TO: CITY CLERK'S OFFICE  
240 W. HUNTINGTON DRIVE  
ARCADIA, CA 91007

OR

Email us at [CityClerk@ArcadiaCA.gov](mailto:CityClerk@ArcadiaCA.gov)

Questions? Please contact us at (626) 574-5455

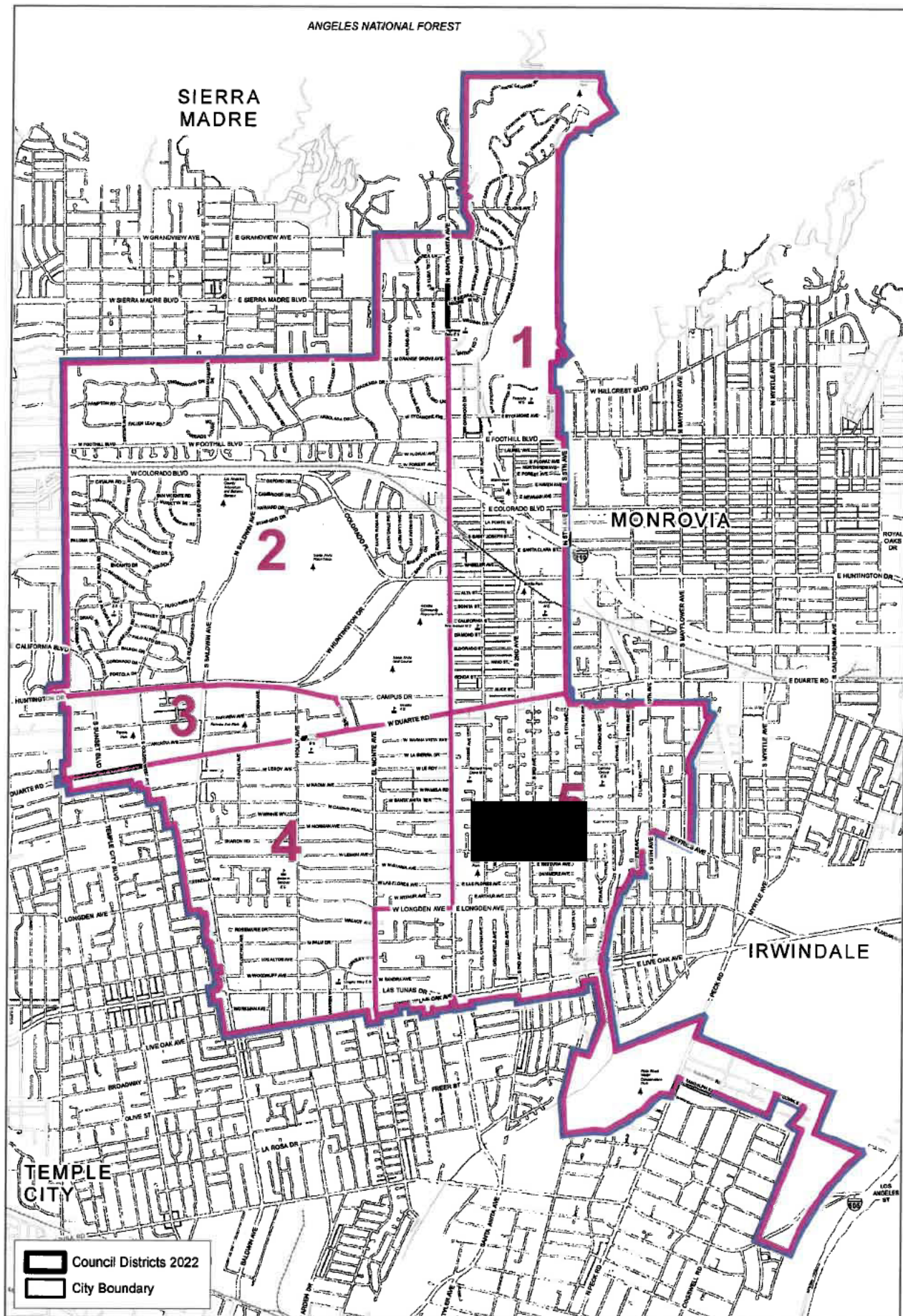

**Council District**  
*City of Arcadia, California*

**RECREATION AND  
PARKS COMMISSION  
APPLICANTS**



# City of Arcadia Board/Commission Application

RECEIVED  
CITY OF ARCADIA

MAR 16 2026

CITY MANAGER

PLEASE PLACE A CHECK MARK NEXT TO THE BOARD OR COMMISSION FOR WHICH YOU WOULD LIKE TO APPLY (more than one selection may be made):

- |   |   |
|---|---|
| <input checked="" type="checkbox"/> Arcadia Beautiful Commission* | <input checked="" type="checkbox"/> Planning Commission             |
| <input type="checkbox"/> Arcadia Museum Commission                | <input checked="" type="checkbox"/> Recreation and Parks Commission |
| <input checked="" type="checkbox"/> Human Resources Commission    | <input checked="" type="checkbox"/> Senior Citizens Commission      |
| <input checked="" type="checkbox"/> Library Board of Trustees     | <input type="checkbox"/> Arcadia Health Commission                  |

NAME JOHNNY TSENG DATE OF BIRTH (mm/dd/yyyy) [REDACTED]

FIRST LAST

RESIDENTIAL ADDRESS [REDACTED] 91006

(Note: Cannot be a mailing address or PO Box)

BUSINESS ADDRESS (HEALTH COMMISSION ONLY) \_\_\_\_\_

I CERTIFY THAT I AM A RESIDENT OF DISTRICT  ONE  TWO  THREE  FOUR  FIVE  
 N/A (Health Commission Only)

PHONE NUMBER [REDACTED] EMAIL ADDRESS [REDACTED]

OCCUPATION Teacher EMPLOYER Hacienda La Puente Unified School District

ARE YOU AN ARCADIA REGISTERED VOTER?  YES  NO

HOW LONG HAVE YOU BEEN A RESIDENT? (If Applicable) 19

PLEASE ANSWER THE QUESTIONS BELOW. YOU MAY USE ADDITIONAL SHEETS OF PAPER AS NECESSARY.

**EDUCATION (Include professional or vocational licenses or certificates)**  
Active Community Member, Interest in community service, betterment of the City of Arcadia, and highly enthusiastic and involved. Would be amazing to have this opportunity to make a difference.

**COMMUNITY INVOLVEMENT (List organization memberships and committee assignments)**  
Active Community Member, Interest in community service, betterment of the City of Arcadia, and highly enthusiastic and involved. Would be amazing to have this opportunity to make a difference.

**PLEASE DESCRIBE ANY BACKGROUND, TRAINING, OR INTERESTS THAT QUALIFY YOU AS AN APPOINTEE**  
Active Community Member, Interest in community service, betterment of the City of Arcadia, and highly enthusiastic and involved. Would be amazing to have this opportunity to make a difference.

**WHAT INTERESTS YOU ABOUT THE BOARD/COMMISSION YOU ARE APPLYING FOR?**  
Active Community Member, Interest in community service, betterment of the City of Arcadia, and highly enthusiastic and involved. Would be amazing to have this opportunity to make a difference.

ARE YOU AWARE OF THE TIME COMMITMENT NECESSARY TO FULFILL THE OBLIGATIONS OF AN APPOINTMENT TO THIS POSITION?

YES  NO

NOTE: FOR LIBRARY BOARD OF TRUSTEE AND PLANNING COMMISSION APPLICATIONS ONLY  
STATE LAW AND THE CITY CONFLICT OF INTEREST CODE REQUIRES THAT LIBRARY BOARD OF TRUSTEE MEMBERS AND PLANNING COMMISSIONERS FILE A STATEMENT OF ECONOMIC INTERESTS (FORM 700) ANNUALLY AS WELL AS RELATED FORMS WHEN ASSUMING AND LEAVING OFFICE (e.g. sources of income, loans, gifts, investments, interest in real property as required by state law). DO YOU AGREE TO FILE ALL REQUIRED FORMS IN A TIMELY MANNER AS REQUIRED BY THE CITY'S FILING OFFICIAL?

YES  NO

---

**\*ARCADIA BEAUTIFUL APPLICANTS ONLY**

ARE YOU AWARE THAT THE PRIMARY FUNCTION OF THE ARCADIA BEAUTIFUL COMMISSION IS TO ACT AS JUDGES FOR THE COMMISSIONS AWARD PROGRAMS (Spring Home, Holiday Decoration, and Water Smart Hero awards)?

YES  NO

DO YOU HAVE THE ABILITY TO TRAVEL BY CAR DURING THE DAY AND IN THE EVENING FOR THE PURPOSE OF JUDGING?

YES  NO

THE ARCADIA BEAUTIFUL COMMISSION USUALLY HAS FOUR REGULAR MEETINGS EACH YEAR WITH ADDITIONAL MEETINGS AND/OR TIME COMMITMENTS SCHEDULED FOR THE PURPOSE OF CONDUCTING JUDGING FOR THE AWARD PROGRAMS, PARTICIPATING IN A 3-4 HOUR HOLIDAY DECORATION AWARD RECOGNITION EVENT, AND PARTICIPATING IN ARBOR DAY PROGRAMS. ADDITIONALLY, PRELIMINARY JUDGING FOR THE SPRING HOME AND HOLIDAY DECORATION AWARDS IS DONE WITH EACH COMMISSIONER TAKING RESPONSIBILITY FOR A SECTION OF THE CITY AND DRIVING THROUGH THE NEIGHBORHOODS TO SELECT THEIR NOMINATIONS FOR FINAL JUDGING BY THE COMMISSION. ARE YOU ABLE TO FULFILL THIS TIME COMMITMENT?

YES  NO

---

I HEREBY CERTIFY THAT THE INFORMATION IS TRUE AND CORRECT TO THE BEST OF MY KNOWLEDGE.



3-6-26  
DATE

NOTE: The City of Arcadia reserves the right to use the information provided on this application to verify your residential address and voter registration status. The information provided on this application is for internal use only and confidential information will not be released to the public.

PLEASE SUBMIT YOUR COMPLETED APPLICATION TO: CITY CLERK'S OFFICE  
240 W. HUNTINGTON DRIVE  
ARCADIA, CA 91007

OR

Email us at [CityClerk@ArcadiaCA.gov](mailto:CityClerk@ArcadiaCA.gov)

Questions? Please contact us at (626) 574-5455

CITY CLERK'S OFFICE  
240 W. HUNTINGTON DRIVE ARCADIA, CA 91007

City Clerk's Office  
City of Arcadia  
P. O. Box 60021  
Arcadia, California 91066

Masters in Arts- Educational Leadership  
Bachelor's in Arts- Child Development

**Arcadia High School Orchestra Benefit Dinner Committee Chair, San Marino Chinese School Board Member, AHS Hispanic Parent Booster Club Vice President, Arcadia Troop 104/333 Assistant Scout Master, Arcadia Citizens Oversight Committee Member. Arcadia Neighborhood Watch Captain**



**Active Community Member, Interest in community service, betterment of the City of Arcadia, and highly enthusiastic and involved. Would be amazing to have this opportunity to make a difference.**

SIERRA MADRE

MONROVIA

IRWINDALE

TEMPLE CITY

-  Council Districts 2022
-  City Boundary



**Council District**  
 City of Arcadia, California

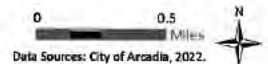



# City of Arcadia Board/Commission Application

RECEIVED

APR 1 2026

PLEASE PLACE A CHECK MARK NEXT TO THE BOARD OR COMMISSION FOR WHICH YOU WOULD LIKE TO APPLY (more than one selection may be made):

CITY OF ARCADIA  
CITY CLERK

- |  |   |
|--|---|
| <input type="checkbox"/> Arcadia Beautiful Commission* | <input type="checkbox"/> Planning Commission                        |
| <input type="checkbox"/> Arcadia Museum Commission     | <input checked="" type="checkbox"/> Recreation and Parks Commission |
| <input type="checkbox"/> Human Resources Commission    | <input type="checkbox"/> Senior Citizens Commission                 |
| <input type="checkbox"/> Library Board of Trustees     | <input type="checkbox"/> Arcadia Health Commission                  |

NAME Mary Jane Card DATE OF BIRTH (mm/dd/yyyy) [REDACTED]  
FIRST LAST

RESIDENTIAL ADDRESS [REDACTED] Arcadia, Ca. 91007  
(Note: Cannot be a mailing address or PO Box)

BUSINESS ADDRESS (HEALTH COMMISSION ONLY) \_\_\_\_\_

I CERTIFY THAT I AM A RESIDENT OF DISTRICT  ONE  TWO  THREE  FOUR  FIVE  
 N/A (Health Commission Only)

PHONE NUMBER [REDACTED] EMAIL ADDRESS [REDACTED]

OCCUPATION retired educator EMPLOYER Temple city Unified School District

ARE YOU AN ARCADIA REGISTERED VOTER?  YES  NO

HOW LONG HAVE YOU BEEN A RESIDENT? (if Applicable) I attended elem through High School in Arcadia. I returned to Arcadia in 1997 to raise my family.

PLEASE ANSWER THE QUESTIONS BELOW. YOU MAY USE ADDITIONAL SHEETS OF PAPER AS NECESSARY

EDUCATION (Include professional or vocational licenses or certificates)  
BA in Human Development  
MA in Special Education from Azusa Pacific University

COMMUNITY INVOLVEMENT (List organization memberships and committee assignments)  
① Community Service Commission - Menloville  
② member of Children's Hospital Guild  
③ Brownie / Girl Scout leader  
④ President of PTA / also on District council PTA member

PLEASE DESCRIBE ANY BACKGROUND, TRAINING, OR INTERESTS THAT QUALIFY YOU AS AN APPOINTEE as mentioned above, I have been active in many youth activities as well as adult activities & organizations.

WHAT INTERESTS YOU ABOUT THE BOARD/COMMISSION YOU ARE APPLYING FOR?  
I have a desire to be part of the community, making decisions/policies as well as serving all of the community. I am especially interested in activities that will bring together the diverse cultures of Arcadia. I now have time to fulfill this interest.

ARE YOU AWARE OF THE TIME COMMITMENT NECESSARY TO FULFILL THE OBLIGATIONS OF AN APPOINTMENT TO THIS POSITION?

YES  NO

NOTE: FOR LIBRARY BOARD OF TRUSTEE AND PLANNING COMMISSION APPLICATIONS ONLY  
STATE LAW AND THE CITY CONFLICT OF INTEREST CODE REQUIRES THAT LIBRARY BOARD OF TRUSTEE MEMBERS AND PLANNING COMMISSIONERS FILE A STATEMENT OF ECONOMIC INTERESTS (FORM 700) ANNUALLY AS WELL AS RELATED FORMS WHEN ASSUMING AND LEAVING OFFICE (e.g. sources of income, loans, gifts, investments, interest in real property as required by state law). DO YOU AGREE TO FILE ALL REQUIRED FORMS IN A TIMELY MANNER AS REQUIRED BY THE CITY'S FILING OFFICIAL?

YES  NO

---

**\*ARCADIA BEAUTIFUL APPLICANTS ONLY**

ARE YOU AWARE THAT THE PRIMARY FUNCTION OF THE ARCADIA BEAUTIFUL COMMISSION IS TO ACT AS JUDGES FOR THE COMMISSIONS AWARD PROGRAMS (Spring Home, Holiday Decoration, and Water Smart Hero awards)?

YES  NO

DO YOU HAVE THE ABILITY TO TRAVEL BY CAR DURING THE DAY AND IN THE EVENING FOR THE PURPOSE OF JUDGING?

YES  NO

THE ARCADIA BEAUTIFUL COMMISSION USUALLY HAS FOUR REGULAR MEETINGS EACH YEAR WITH ADDITIONAL MEETINGS AND/OR TIME COMMITMENTS SCHEDULED FOR THE PURPOSE OF CONDUCTING JUDGING FOR THE AWARD PROGRAMS, PARTICIPATING IN A 3-4 HOUR HOLIDAY DECORATION AWARD RECOGNITION EVENT, AND PARTICIPATING IN ARBOR DAY PROGRAMS. ADDITIONALLY, PRELIMINARY JUDGING FOR THE SPRING HOME AND HOLIDAY DECORATION AWARDS IS DONE WITH EACH COMMISSIONER TAKING RESPONSIBILITY FOR A SECTION OF THE CITY AND DRIVING THROUGH THE NEIGHBORHOODS TO SELECT THEIR NOMINATIONS FOR FINAL JUDGING BY THE COMMISSION. ARE YOU ABLE TO FULFILL THIS TIME COMMITMENT?

YES  NO

---

I HEREBY CERTIFY THAT THE FOREGOING INFORMATION IS TRUE AND CORRECT TO THE BEST OF MY KNOWLEDGE.

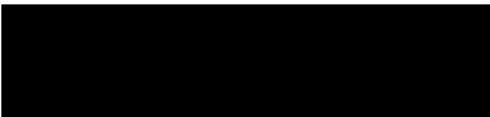

4/1/26  
DATE

NOTE: The City of Arcadia reserves the right to use the information provided on this application to verify your residential address and voter registration status. The information provided on this application is for internal use only and confidential information will not be released to the public.

PLEASE SUBMIT YOUR COMPLETED APPLICATION TO: CITY CLERK'S OFFICE  
240 W. HUNTINGTON DRIVE  
ARCADIA, CA 91007

OR

Email us at [CityClerk@ArcadiaCA.gov](mailto:CityClerk@ArcadiaCA.gov)



Questions? Please contact us at (626) 574-5455

SIERRA MADRE

MONROVIA

IRWINDALE

TEMPLE CITY

-  Council Districts 2022
-  City Boundary

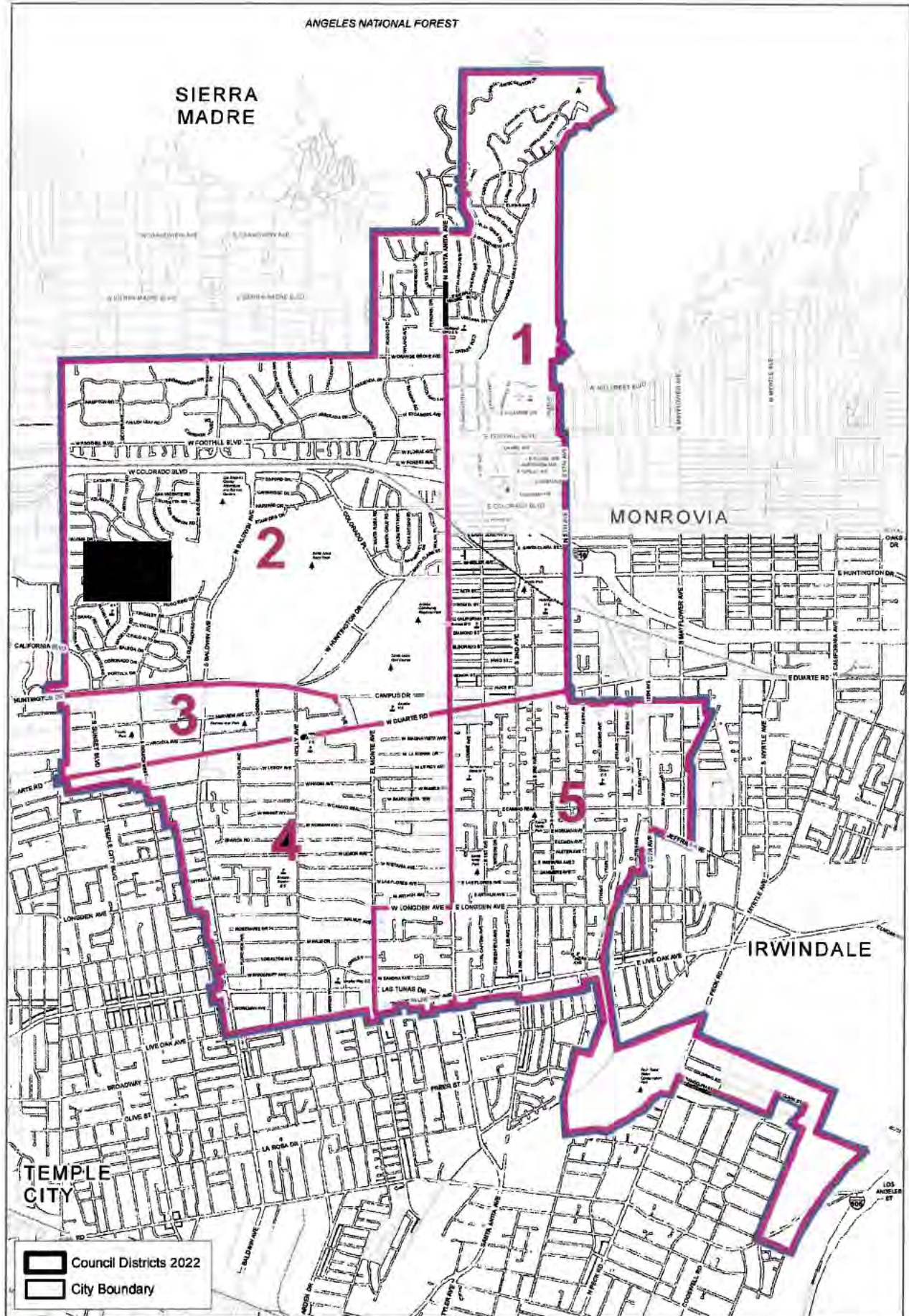

**Council District**  
*City of Arcadia, California*



# City of Arcadia Board/Commission Application

RECEIVED

APR 20 2026

PLEASE PLACE A CHECK MARK NEXT TO THE BOARD OR COMMISSION FOR WHICH YOU WOULD LIKE TO APPLY (more than one selection may be made):

CITY CLERK

- |  |   |
|--|---|
| <input type="checkbox"/> Arcadia Beautiful Commission*         | <input type="checkbox"/> Planning Commission                        |
| <input type="checkbox"/> Arcadia Museum Commission             | <input checked="" type="checkbox"/> Recreation and Parks Commission |
| <input checked="" type="checkbox"/> Human Resources Commission | <input type="checkbox"/> Senior Citizens Commission                 |
| <input type="checkbox"/> Library Board of Trustees             | <input type="checkbox"/> Arcadia Health Commission                  |

NAME Kenneth Proulx DATE OF BIRTH (mm/dd/yyyy) [REDACTED]

FIRST LAST

RESIDENTIAL ADDRESS [REDACTED] Arcadia, CA, 91006

(Note: Cannot be a mailing address or PO Box)

BUSINESS ADDRESS (HEALTH COMMISSION ONLY) \_\_\_\_\_

I CERTIFY THAT I AM A RESIDENT OF DISTRICT  ONE  TWO  THREE  FOUR  FIVE  
 N/A (Health Commission Only)

PHONE NUMBER [REDACTED] EMAIL ADDRESS [REDACTED]

OCCUPATION Executive EMPLOYER KP Consulting Group LLC

ARE YOU AN ARCADIA REGISTERED VOTER?  YES  NO

HOW LONG HAVE YOU BEEN A RESIDENT? (If Applicable) 18 years

PLEASE ANSWER THE QUESTIONS BELOW. YOU MAY USE ADDITIONAL SHEETS OF PAPER AS NECESSARY.

**EDUCATION (Include professional or vocational licenses or certificates)**

- Master's degree, Stanford University Graduate School of Business
- Bachelor's degree, UC Irvine

**COMMUNITY INVOLVEMENT (List organization memberships and committee assignments)**

President and Vice President of the School Site Councils (SSC) at Camino Grove Elementary School and Dana Middle School for 10+ years. Community representative at Local Control and Accountability Plan (LCAP) Stakeholder Meetings in 2025. Parade Director for Dana Middle School in the 2025-2026 school year.

**PLEASE DESCRIBE ANY BACKGROUND, TRAINING, OR INTERESTS THAT QUALIFY YOU AS AN APPOINTEE**

Top-tier education in HR, finance, leadership, operations through Master's degree program at Stanford University Graduate School of Business. Leadership and management experience useful to HR Commissions gained as C-level executive managing 17K+ people in 14 countries. As a pickleball and tennis player in Arcadia, I am familiar with courts, park facilities, and resource issues that are pertinent to the Recreation and Parks Commission.

**WHAT INTERESTS YOU ABOUT THE BOARD/COMMISSION YOU ARE APPLYING FOR?**

I have a track record of volunteerism within the Arcadia Unified School District and am in tune to the changes that Arcadia has been going through since I moved here in January 2008. I am volunteering because I have relevant skills and experience and leadership experience that I know I can leverage to help improve our Arcadia community. I want to make a positive difference and help Arcadia run smoothly and serve its citizens to the best extent possible.

ARE YOU AWARE OF THE TIME COMMITMENT NECESSARY TO FULFILL THE OBLIGATIONS OF AN APPOINTMENT TO THIS POSITION?

YES  NO

NOTE: FOR LIBRARY BOARD OF TRUSTEE AND PLANNING COMMISSION APPLICATIONS ONLY  
STATE LAW AND THE CITY CONFLICT OF INTEREST CODE REQUIRES THAT LIBRARY BOARD OF TRUSTEE MEMBERS AND PLANNING COMMISSIONERS FILE A STATEMENT OF ECONOMIC INTERESTS (FORM 700) ANNUALLY AS WELL AS RELATED FORMS WHEN ASSUMING AND LEAVING OFFICE (e.g. sources of income, loans, gifts, investments, interest in real property as required by state law). DO YOU AGREE TO FILE ALL REQUIRED FORMS IN A TIMELY MANNER AS REQUIRED BY THE CITY'S FILING OFFICIAL?

YES  NO

---

**\*ARCADIA BEAUTIFUL APPLICANTS ONLY**

ARE YOU AWARE THAT THE PRIMARY FUNCTION OF THE ARCADIA BEAUTIFUL COMMISSION IS TO ACT AS JUDGES FOR THE COMMISSIONS AWARD PROGRAMS (Spring Home, Holiday Decoration, and Water Smart Hero awards)?

YES  NO

DO YOU HAVE THE ABILITY TO TRAVEL BY CAR DURING THE DAY AND IN THE EVENING FOR THE PURPOSE OF JUDGING?

YES  NO

THE ARCADIA BEAUTIFUL COMMISSION USUALLY HAS FOUR REGULAR MEETINGS EACH YEAR WITH ADDITIONAL MEETINGS AND/OR TIME COMMITMENTS SCHEDULED FOR THE PURPOSE OF CONDUCTING JUDGING FOR THE AWARD PROGRAMS, PARTICIPATING IN A 3-4 HOUR HOLIDAY DECORATION AWARD RECOGNITION EVENT, AND PARTICIPATING IN ARBOR DAY PROGRAMS. ADDITIONALLY, PRELIMINARY JUDGING FOR THE SPRING HOME AND HOLIDAY DECORATION AWARDS IS DONE WITH EACH COMMISSIONER TAKING RESPONSIBILITY FOR A SECTION OF THE CITY AND DRIVING THROUGH THE NEIGHBORHOODS TO SELECT THEIR NOMINATIONS FOR FINAL JUDGING BY THE COMMISSION. ARE YOU ABLE TO FULFILL THIS TIME COMMITMENT?

YES  NO

---

I HEREBY CERTIFY THAT THE FOREGOING INFORMATION IS TRUE AND CORRECT TO THE BEST OF MY KNOWLEDGE.



SIGNATURE

4/18/2026

DATE

NOTE: The City of Arcadia reserves the right to use the information provided on this application to verify your residential address and voter registration status. The information provided on this application is for internal use only and confidential information will not be released to the public.

PLEASE SUBMIT YOUR COMPLETED APPLICATION TO: CITY CLERK'S OFFICE  
240 W. HUNTINGTON DRIVE  
ARCADIA, CA 91007

OR

Email us at [CityClerk@ArcadiaCA.gov](mailto:CityClerk@ArcadiaCA.gov)



Questions? Please contact us at (626) 574-5455

SIERRA MADRE

MONROVIA

IRWINDALE

TEMPLE CITY

-  Council Districts 2022
-  City Boundary

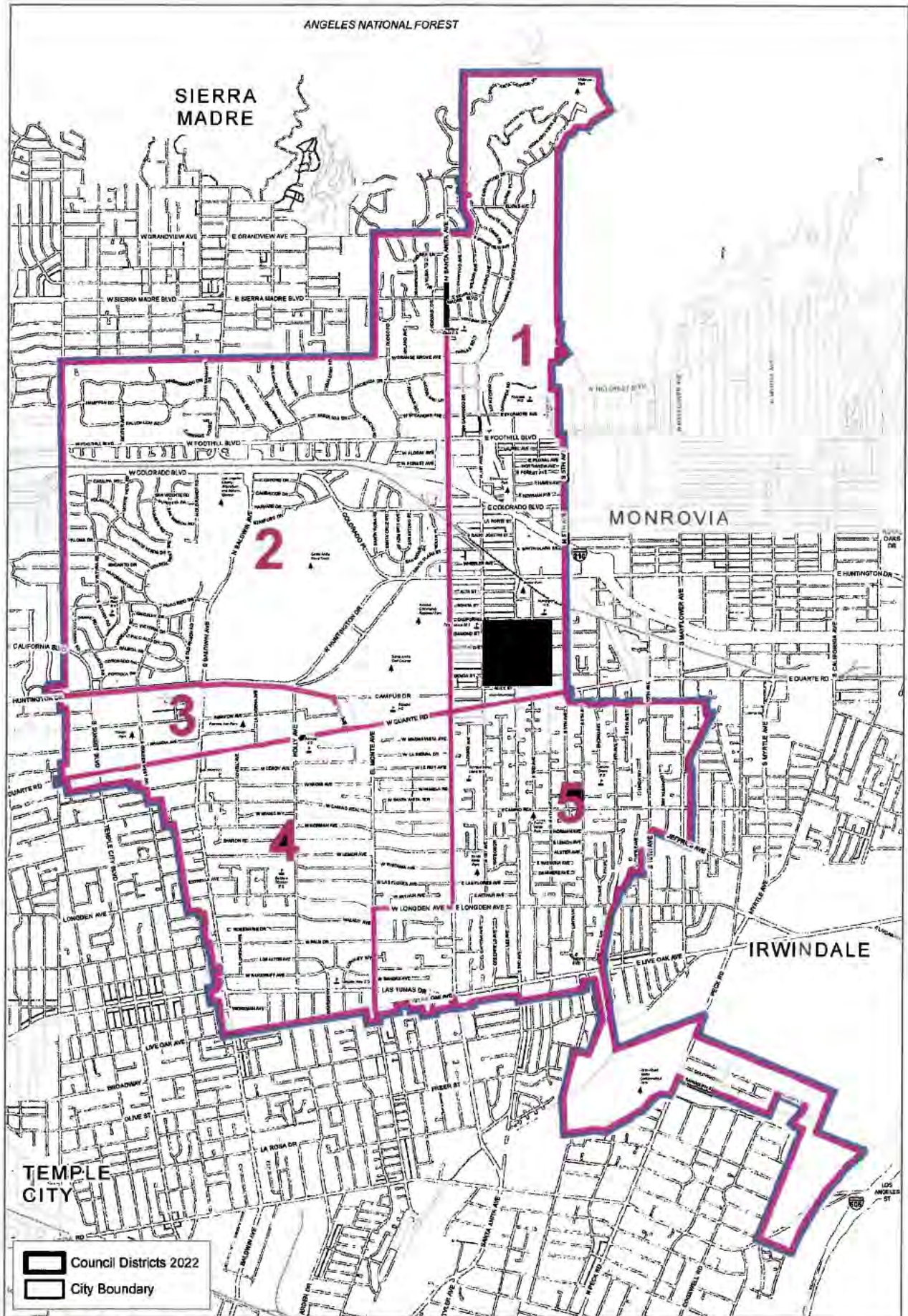

**Council District**  
*City of Arcadia, California*

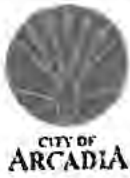

# City of Arcadia Board/Commission Application

RECEIVED

APR 30 2026

PLEASE PLACE A CHECK MARK NEXT TO THE BOARD OR COMMISSION FOR WHICH YOU WOULD LIKE TO APPLY (more than one selection may be made):

- Arcadia Beautiful Commission\*
- Arcadia Museum Commission
- Human Resources Commission
- Library Board of Trustees

- Planning Commission
- Recreation and Parks Commission
- Senior Citizens Commission
- Arcadia Health Commission

CITY OF ARCADIA  
CITY CLERK

NAME Robert Gibson DATE OF BIRTH (mm/dd/yyyy) [REDACTED]  
FIRST LAST

RESIDENTIAL ADDRESS [REDACTED] Arcadia, CA 91006

(Note: Cannot be a mailing address or PO Box)

BUSINESS ADDRESS (HEALTH COMMISSION ONLY) \_\_\_\_\_

I CERTIFY THAT I AM A RESIDENT OF DISTRICT  ONE  TWO  THREE  FOUR  FIVE  
 N/A (Health Commission Only)

PHONE NUMBER [REDACTED] EMAIL ADDRESS [REDACTED]

OCCUPATION Vice President of Product EMPLOYER Nucleus Security

ARE YOU AN ARCADIA REGISTERED VOTER?  YES  NO

HOW LONG HAVE YOU BEEN A RESIDENT? (If Applicable) 4 months

PLEASE ANSWER THE QUESTIONS BELOW. YOU MAY USE ADDITIONAL SHEETS OF PAPER AS NECESSARY.

EDUCATION (Include professional or vocational licenses or certificates)

MBA; UCLA 2017 | MA, History; Vanderbilt University 2011 | BA, History; UC Berkeley 2009

COMMUNITY INVOLVEMENT (List organization memberships and committee assignments)

Parent volunteer, Santa Anita Little League

PLEASE DESCRIBE ANY BACKGROUND, TRAINING, OR INTERESTS THAT QUALIFY YOU AS AN APPOINTEE

With a career in product development, I specialize in bridging the gap between those who provide resources and the communities who rely on them—an expertise I've honed by managing platforms used by thousands daily. My professional focus is on facilitating clear communication, reconciling diverse feedback, and translating public needs into actionable goals, all of which are central to the commission's role in fostering participation and alignment with citizens

WHAT INTERESTS YOU ABOUT THE BOARD/COMMISSION YOU ARE APPLYING FOR?

As a new resident of Arcadia, I am eager to contribute to the stewardship of our city's exceptional recreation resources, which my family and I have already begun to enjoy deeply. Watching my son learn to play baseball on city fields with the Santa Anita Little League has given me a firsthand appreciation for the vital role these spaces play in fostering community and youth development. I am motivated by the opportunity to apply my professional experience in resource management to ensure these facilities are preserved and thoughtfully developed for the benefit of all our fellow community members.

ARE YOU AWARE OF THE TIME COMMITMENT NECESSARY TO FULFILL THE OBLIGATIONS OF AN APPOINTMENT TO THIS POSITION?

YES  NO

NOTE: FOR LIBRARY BOARD OF TRUSTEE AND PLANNING COMMISSION APPLICATIONS ONLY  
STATE LAW AND THE CITY CONFLICT OF INTEREST CODE REQUIRES THAT LIBRARY BOARD OF TRUSTEE MEMBERS AND PLANNING COMMISSIONERS FILE A STATEMENT OF ECONOMIC INTERESTS (FORM 700) ANNUALLY AS WELL AS RELATED FORMS WHEN ASSUMING AND LEAVING OFFICE (e.g. sources of income, loans, gifts, investments, interest in real property as required by state law). DO YOU AGREE TO FILE ALL REQUIRED FORMS IN A TIMELY MANNER AS REQUIRED BY THE CITY'S FILING OFFICIAL?

YES  NO

---

**\*ARCADIA BEAUTIFUL APPLICANTS ONLY**

ARE YOU AWARE THAT THE PRIMARY FUNCTION OF THE ARCADIA BEAUTIFUL COMMISSION IS TO ACT AS JUDGES FOR THE COMMISSIONS AWARD PROGRAMS (Spring Home, Holiday Decoration, and Water Smart Hero awards)?

YES  NO

DO YOU HAVE THE ABILITY TO TRAVEL BY CAR DURING THE DAY AND IN THE EVENING FOR THE PURPOSE OF JUDGING?

YES  NO

THE ARCADIA BEAUTIFUL COMMISSION USUALLY HAS FOUR REGULAR MEETINGS EACH YEAR WITH ADDITIONAL MEETINGS AND/OR TIME COMMITMENTS SCHEDULED FOR THE PURPOSE OF CONDUCTING JUDGING FOR THE AWARD PROGRAMS, PARTICIPATING IN A 3-4 HOUR HOLIDAY DECORATION AWARD RECOGNITION EVENT, AND PARTICIPATING IN ARBOR DAY PROGRAMS. ADDITIONALLY, PRELIMINARY JUDGING FOR THE SPRING HOME AND HOLIDAY DECORATION AWARDS IS DONE WITH EACH COMMISSIONER TAKING RESPONSIBILITY FOR A SECTION OF THE CITY AND DRIVING THROUGH THE NEIGHBORHOODS TO SELECT THEIR NOMINATIONS FOR FINAL JUDGING BY THE COMMISSION. ARE YOU ABLE TO FULFILL THIS TIME COMMITMENT?

YES  NO

---

I HEREBY CERTIFY THAT THE FOREGOING INFORMATION IS TRUE AND CORRECT TO THE BEST OF MY KNOWLEDGE.

Robert Gibson

04/28/2026

DATE

NOTE: The City of Arcadia reserves the right to use the information provided on this application to verify your residential address and voter registration status. The information provided on this application is for internal use only and confidential information will not be released to the public.

PLEASE SUBMIT YOUR COMPLETED APPLICATION TO: CITY CLERK'S OFFICE  
240 W. HUNTINGTON DRIVE  
ARCADIA, CA 91007

OR

Email us at [CityClerk@ArcadiaCA.gov](mailto:CityClerk@ArcadiaCA.gov)

Questions? Please contact us at (626) 574-5455

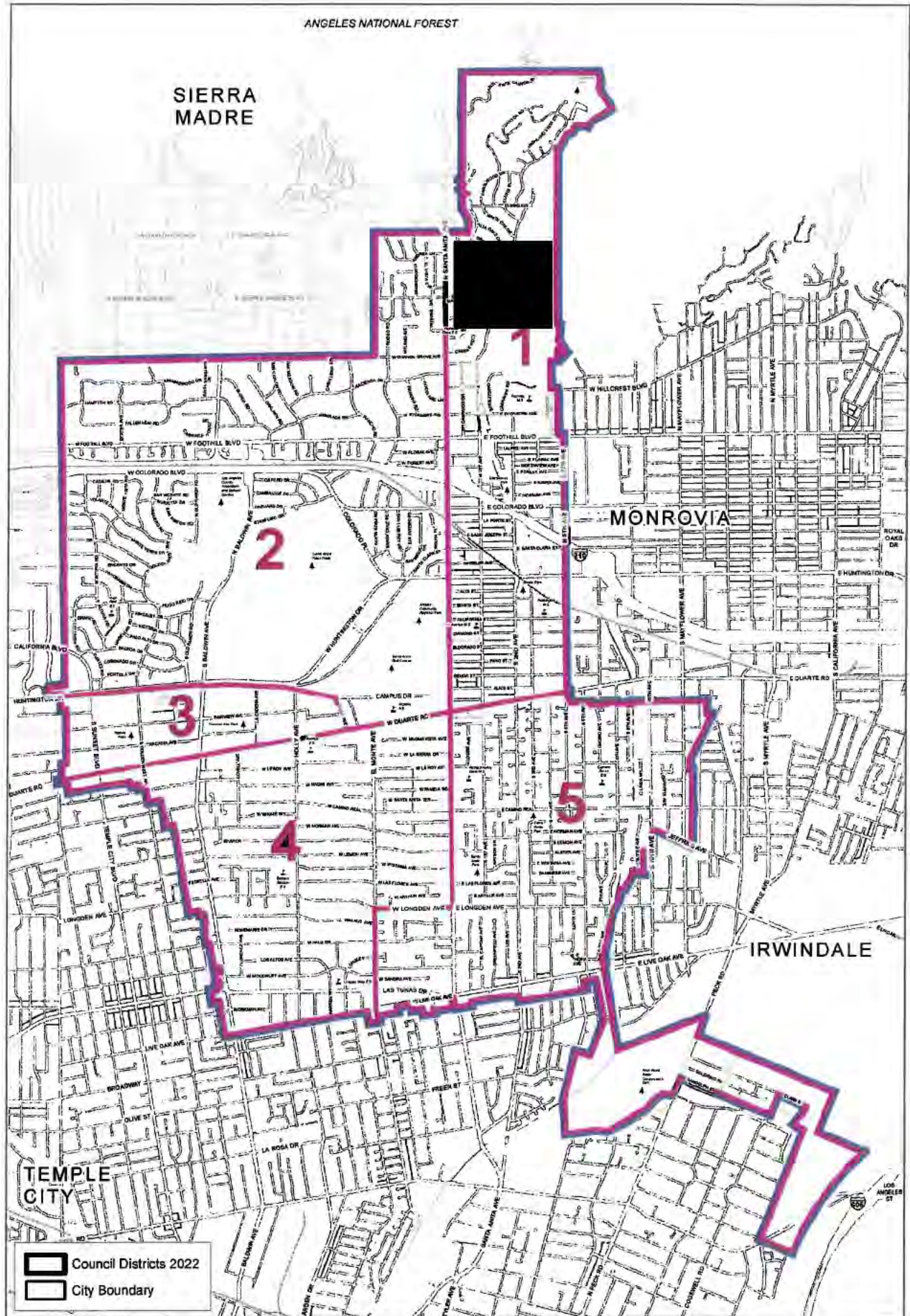

SIERRA MADRE



TEMPLE CITY

MONROVIA

IRWINDALE

 Council Districts 2022  
 City Boundary



**Council District**  
 City of Arcadia, California



# City of Arcadia Board/Commission Application

RECEIVED

MAY 4 2026

CITY OF ARCADIA

PLEASE PLACE A CHECK MARK NEXT TO THE BOARD OR COMMISSION FOR WHICH YOU WOULD LIKE TO APPLY (more than one selection may be made):

- |  |   |
|--|---|
| <input type="checkbox"/> Arcadia Beautiful Commission* | <input checked="" type="checkbox"/> Planning Commission             |
| <input type="checkbox"/> Arcadia Museum Commission     | <input checked="" type="checkbox"/> Recreation and Parks Commission |
| <input type="checkbox"/> Human Resources Commission    | <input type="checkbox"/> Senior Citizens Commission                 |
| <input type="checkbox"/> Library Board of Trustees     | <input type="checkbox"/> Arcadia Health Commission                  |

NAME Ricky Lau DATE OF BIRTH (mm/dd/yyyy) [REDACTED]

FIRST LAST

RESIDENTIAL ADDRESS [REDACTED] Arcadia, CA 91006

(Note: Cannot be a mailing address or PO Box)

BUSINESS ADDRESS (HEALTH COMMISSION ONLY) \_\_\_\_\_

I CERTIFY THAT I AM A RESIDENT OF DISTRICT  ONE  TWO  THREE  FOUR  FIVE  
 N/A (Health Commission Only)

PHONE NUMBER [REDACTED] EMAIL ADDRESS [REDACTED]

OCCUPATION IT EMPLOYER Los Angeles County

ARE YOU AN ARCADIA REGISTERED VOTER?  YES  NO

HOW LONG HAVE YOU BEEN A RESIDENT? (If Applicable) 19 years

PLEASE ANSWER THE QUESTIONS BELOW. YOU MAY USE ADDITIONAL SHEETS OF PAPER AS NECESSARY.

EDUCATION (Include professional or vocational licenses or certificates)  
Bachelor degree of Computer Science

COMMUNITY INVOLVEMENT (List organization memberships and committee assignments)  
Volunteer of Arcadia Chinese Parents Booster Club in Arcadia Hight School.  
Director of Arcadia Chinese Association.

PLEASE DESCRIBE ANY BACKGROUND, TRAINING, OR INTERESTS THAT QUALIFY YOU AS AN APPOINTEE  
I am self-motivated and proactive. In my long-time career, I have been working in project study, project analysis, and project management involving IT developments in the government entity.

WHAT INTERESTS YOU ABOUT THE BOARD/COMMISSION YOU ARE APPLYING FOR?  
Bring my skills and try to improve our community to be in better shape.

ARE YOU AWARE OF THE TIME COMMITMENT NECESSARY TO FULFILL THE OBLIGATIONS OF AN APPOINTMENT TO THIS POSITION?

YES  NO

NOTE: FOR LIBRARY BOARD OF TRUSTEE AND PLANNING COMMISSION APPLICATIONS ONLY  
STATE LAW AND THE CITY CONFLICT OF INTEREST CODE REQUIRES THAT LIBRARY BOARD OF TRUSTEE MEMBERS AND PLANNING COMMISSIONERS FILE A STATEMENT OF ECONOMIC INTERESTS (FORM 700) ANNUALLY AS WELL AS RELATED FORMS WHEN ASSUMING AND LEAVING OFFICE (e.g. sources of income, loans, gifts, investments, interest in real property as required by state law). DO YOU AGREE TO FILE ALL REQUIRED FORMS IN A TIMELY MANNER AS REQUIRED BY THE CITY'S FILING OFFICIAL?

YES  NO

---

**\*ARCADIA BEAUTIFUL APPLICANTS ONLY**

ARE YOU AWARE THAT THE PRIMARY FUNCTION OF THE ARCADIA BEAUTIFUL COMMISSION IS TO ACT AS JUDGES FOR THE COMMISSIONS AWARD PROGRAMS (Spring Home, Holiday Decoration, and Water Smart Hero awards)?

YES  NO

DO YOU HAVE THE ABILITY TO TRAVEL BY CAR DURING THE DAY AND IN THE EVENING FOR THE PURPOSE OF JUDGING?

YES  NO

THE ARCADIA BEAUTIFUL COMMISSION USUALLY HAS FOUR REGULAR MEETINGS EACH YEAR WITH ADDITIONAL MEETINGS AND/OR TIME COMMITMENTS SCHEDULED FOR THE PURPOSE OF CONDUCTING JUDGING FOR THE AWARD PROGRAMS, PARTICIPATING IN A 3-4 HOUR HOLIDAY DECORATION AWARD RECOGNITION EVENT, AND PARTICIPATING IN ARBOR DAY PROGRAMS. ADDITIONALLY, PRELIMINARY JUDGING FOR THE SPRING HOME AND HOLIDAY DECORATION AWARDS IS DONE WITH EACH COMMISSIONER TAKING RESPONSIBILITY FOR A SECTION OF THE CITY AND DRIVING THROUGH THE NEIGHBORHOODS TO SELECT THEIR NOMINATIONS FOR FINAL JUDGING BY THE COMMISSION. ARE YOU ABLE TO FULFILL THIS TIME COMMITMENT?

YES  NO

---

I HEREBY CERTIFY THAT THE FOREGOING INFORMATION IS TRUE AND CORRECT TO THE BEST OF MY KNOWLEDGE.

  
SIGNATURE

5/2/2026

DATE

NOTE: The City of Arcadia reserves the right to use the information provided on this application to verify your residential address and voter registration status. The information provided on this application is for internal use only and confidential information will not be released to the public.

PLEASE SUBMIT YOUR COMPLETED APPLICATION TO: CITY CLERK'S OFFICE  
240 W. HUNTINGTON DRIVE  
ARCADIA, CA 91007

OR

Email us at [CityClerk@ArcadiaCA.gov](mailto:CityClerk@ArcadiaCA.gov)



Questions? Please contact us at (626) 574-5455

SIERRA MADRE

MONROVIA

IRWINDALE

TEMPLE CITY

 Council Districts 2022  
 City Boundary

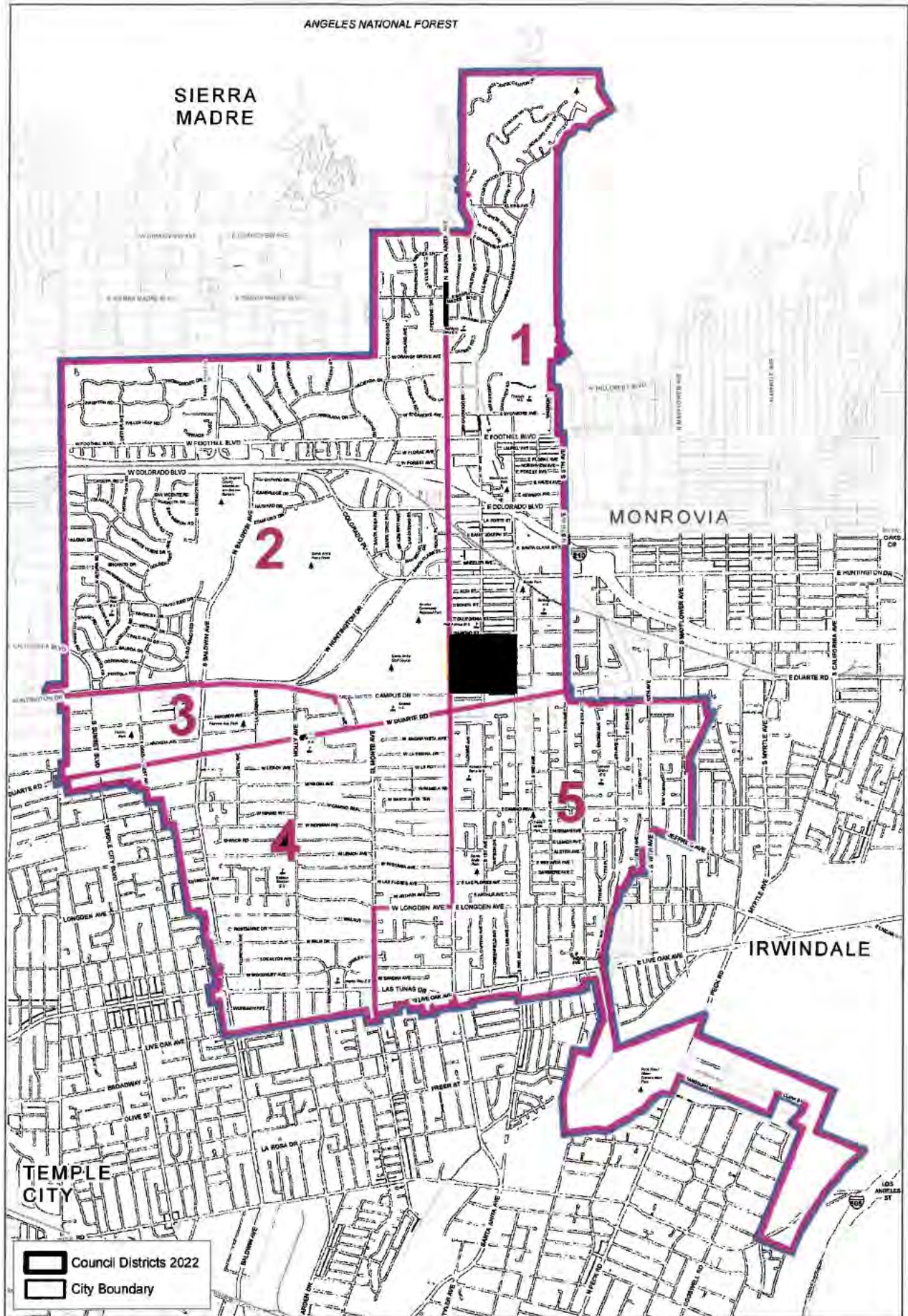

**Council District**  
 City of Arcadia, California



# City of Arcadia

## Board/Commission Application

RECEIVED

APR 23 2026

PLEASE PLACE A CHECK MARK NEXT TO THE BOARD OR COMMISSION FOR WHICH YOU WOULD LIKE TO APPLY (more than one selection may be made):

CITY OF ARCADIA

- Arcadia Beautiful Commission\*
- Arcadia Museum Commission
- Human Resources Commission
- Library Board of Trustees

- Planning Commission
- Recreation and Parks Commission
- Senior Citizens Commission
- Arcadia Health Commission

① opt  
② opt

NAME Qun (Connie) Liao DATE OF BIRTH (mm/dd/yyyy) [REDACTED]

RESIDENTIAL ADDRESS [REDACTED] Arcadia CA  
(Note: Cannot be a mailing address or PO Box)

BUSINESS ADDRESS (HEALTH COMMISSION ONLY) \_\_\_\_\_

I CERTIFY THAT I AM A RESIDENT OF DISTRICT  ONE  TWO  THREE  FOUR  FIVE  
 N/A (Health Commission Only)

PHONE NUMBER [REDACTED] EMAIL ADDRESS [REDACTED]

OCCUPATION retired EMPLOYER [REDACTED]

ARE YOU AN ARCADIA REGISTERED VOTER?  YES  NO

HOW LONG HAVE YOU BEEN A RESIDENT? (if Applicable) 28 years

PLEASE ANSWER THE QUESTIONS BELOW. YOU MAY USE ADDITIONAL SHEETS OF PAPER AS NECESSARY.

EDUCATION (Include professional or vocational licenses or certificates)  
Dual - Master Degrees, Economics and MIS

COMMUNITY INVOLVEMENT (List organization memberships and committee assignments)  
Arcadia Chinese Association  
Arcadia Public Library Board of Trustees

PLEASE DESCRIBE ANY BACKGROUND, TRAINING, OR INTERESTS THAT QUALIFY YOU AS AN APPOINTEE  
Senior Director, Data Management, Market Share  
Ex-President, Arcadia Chinese Association  
Committee Chair, Boy Scout Troop 138

WHAT INTERESTS YOU ABOUT THE BOARD/COMMISSION YOU ARE APPLYING FOR?  
As the board director I worked with Arcadia Community center of ACA to co-host many community events, i.e. Moon Festival, Seniors luncheon, etc.

ARE YOU AWARE OF THE TIME COMMITMENT NECESSARY TO FULFILL THE OBLIGATIONS OF AN APPOINTMENT TO THIS POSITION?

YES  NO

NOTE: FOR LIBRARY BOARD OF TRUSTEE AND PLANNING COMMISSION APPLICATIONS ONLY  
STATE LAW AND THE CITY CONFLICT OF INTEREST CODE REQUIRES THAT LIBRARY BOARD OF TRUSTEE MEMBERS AND PLANNING COMMISSIONERS FILE A STATEMENT OF ECONOMIC INTERESTS (FORM 700) ANNUALLY AS WELL AS RELATED FORMS WHEN ASSUMING AND LEAVING OFFICE (e.g. sources of income, loans, gifts, investments, interest in real property as required by state law). DO YOU AGREE TO FILE ALL REQUIRED FORMS IN A TIMELY MANNER AS REQUIRED BY THE CITY'S FILING OFFICIAL?

YES  NO

---

**\*ARCADIA BEAUTIFUL APPLICANTS ONLY**

ARE YOU AWARE THAT THE PRIMARY FUNCTION OF THE ARCADIA BEAUTIFUL COMMISSION IS TO ACT AS JUDGES FOR THE COMMISSIONS AWARD PROGRAMS (Spring Home, Holiday Decoration, and Water Smart Hero awards)?

YES  NO

DO YOU HAVE THE ABILITY TO TRAVEL BY CAR DURING THE DAY AND IN THE EVENING FOR THE PURPOSE OF JUDGING?

YES  NO

THE ARCADIA BEAUTIFUL COMMISSION USUALLY HAS FOUR REGULAR MEETINGS EACH YEAR WITH ADDITIONAL MEETINGS AND/OR TIME COMMITMENTS SCHEDULED FOR THE PURPOSE OF CONDUCTING JUDGING FOR THE AWARD PROGRAMS, PARTICIPATING IN A 3-4 HOUR HOLIDAY DECORATION AWARD RECOGNITION EVENT, AND PARTICIPATING IN ARBOR DAY PROGRAMS. ADDITIONALLY, PRELIMINARY JUDGING FOR THE SPRING HOME AND HOLIDAY DECORATION AWARDS IS DONE WITH EACH COMMISSIONER TAKING RESPONSIBILITY FOR A SECTION OF THE CITY AND DRIVING THROUGH THE NEIGHBORHOODS TO SELECT THEIR NOMINATIONS FOR FINAL JUDGING BY THE COMMISSION. ARE YOU ABLE TO FULFILL THIS TIME COMMITMENT?

YES  NO

---

I HEREBY CERTIFY THAT THE FOREGOING INFORMATION IS TRUE AND CORRECT TO THE BEST OF MY KNOWLEDGE.



SIGNATURE

4/22/2026

DATE

NOTE: The City of Arcadia reserves the right to use the information provided on this application to verify your residential address and voter registration status. The information provided on this application is for internal use only and confidential information will not be released to the public.

PLEASE SUBMIT YOUR COMPLETED APPLICATION TO: CITY CLERK'S OFFICE  
240 W. HUNTINGTON DRIVE  
ARCADIA, CA 91007

OR

Email us at [CityClerk@ArcadiaCA.gov](mailto:CityClerk@ArcadiaCA.gov)

Questions? Please contact us at (626) 574-5455

SIERRA MADRE

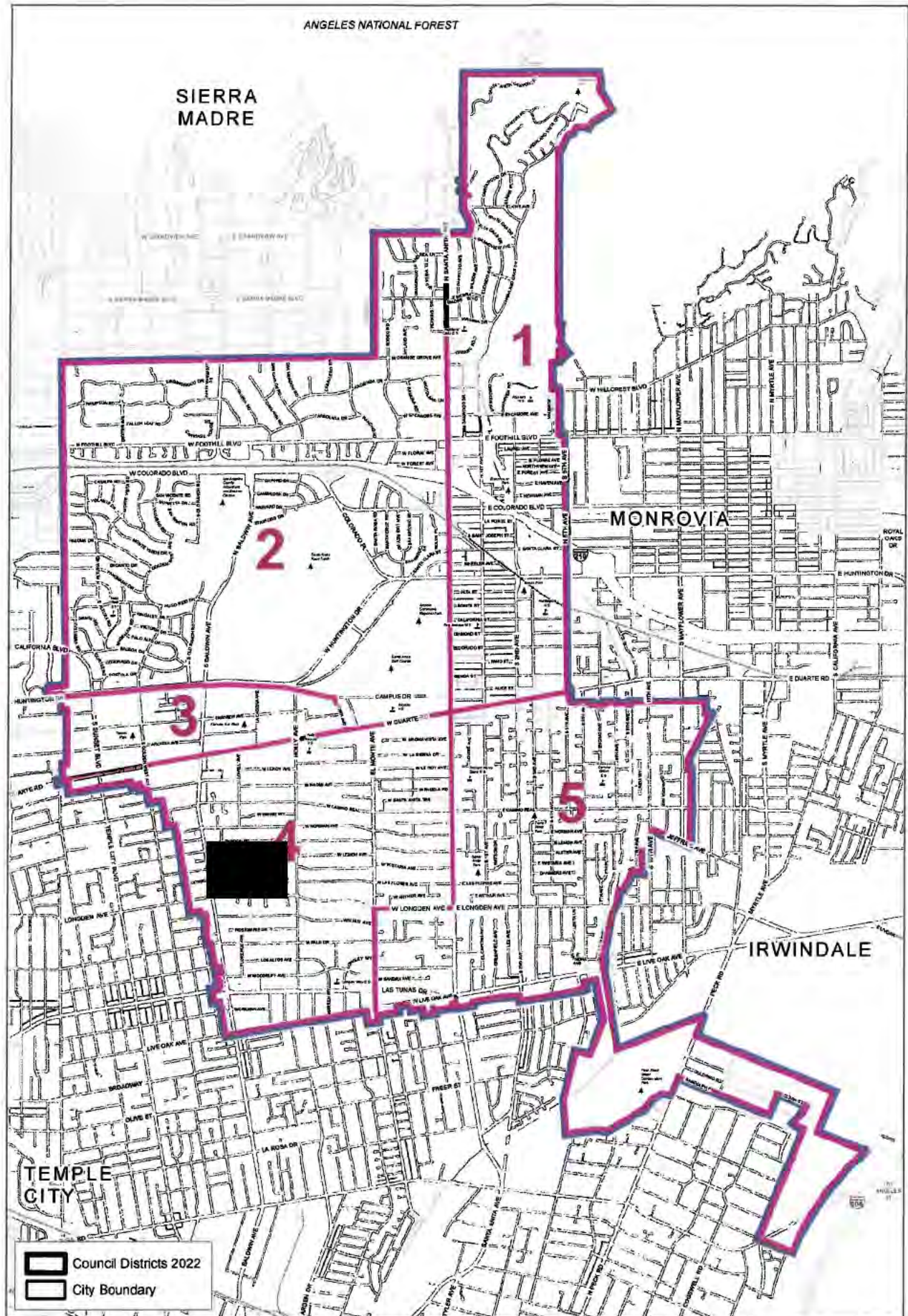

**Council District**  
 City of Arcadia, California



# City of Arcadia Board/Commission Application

RECEIVED

MAY 13 2026

CITY OF ARCADIA  
CIVIL SERVICE

PLEASE PLACE A CHECK MARK NEXT TO THE BOARD OR COMMISSION FOR WHICH YOU WOULD LIKE TO APPLY (more than one selection may be made):

- Arcadia Beautiful Commission\*
- Arcadia Museum Commission
- Human Resources Commission
- Library Board of Trustees
- Planning Commission
- Recreation and Parks Commission
- Senior Citizens Commission
- Arcadia Health Commission

NAME YUTING CHENG DATE OF BIRTH (mm/dd/yyyy) [REDACTED]

FIRST LAST

RESIDENTIAL ADDRESS [REDACTED] ARCADIA CA 91007

(Note: Cannot be a mailing address or PO Box)

BUSINESS ADDRESS (HEALTH COMMISSION ONLY) \_\_\_\_\_

I CERTIFY THAT I AM A RESIDENT OF DISTRICT  ONE  TWO  THREE  FOUR  FIVE  
 N/A (Health Commission Only)

PHONE NUMBER [REDACTED] EMAIL ADDRESS [REDACTED]

OCCUPATION WEALTH ADVISOR EMPLOYER TYWL CPA

ARE YOU AN ARCADIA REGISTERED VOTER?  YES  NO

HOW LONG HAVE YOU BEEN A RESIDENT? (If Applicable) 4 YEARS

PLEASE ANSWER THE QUESTIONS BELOW. YOU MAY USE ADDITIONAL SHEETS OF PAPER AS NECESSARY.

**EDUCATION (Include professional or vocational licenses or certificates)**

M.B.A. -UNIVERSITY OF CALIFORNIA, RIVERSIDE;CHARTER FINANCIAL CONSULTANT - AMERICAN COLLEGE  
CERTIFIED FINACIAL PLANNER - CFP BOARD; NOTARY ; NMLS ( S.A.F.E. REGISTERED; FINRA SERIES 7,63,66

**COMMUNITY INVOLVEMENT (List organization memberships and committee assignments)**

ARCADIA CHAMBER OF COMMERCE IN 2024

**PLEASE DESCRIBE ANY BACKGROUND, TRAINING, OR INTERESTS THAT QUALIFY YOU AS AN APPOINTEE**

With over 17 years of experience in licensed financial planning, I pride myself a client-focused advocacy, with bi-district knowledge of Arcadia- I lived in Arcadia Dis 5 before now. As a current HOA board member, my experience includes public presentation, hosting, and active volunteer work, from local library events to the City of Hope Walk for Hope. I am committed to transparent governance, community involvement, and ensuring fiscal stability for all Arcadia residents.

**WHAT INTERESTS YOU ABOUT THE BOARD/COMMISSION YOU ARE APPLYING FOR?**

With a background rooted in analytical expertise, fiscal responsibility, and proactive community engagement, I am eager to bring a unique, results-driven perspective to the County Board. As an Arcadia resident raising a young family, I am deeply invested in our community's future and committed to ensuring a secure, prosperous environment for all residents. Furthermore, as a fluent speaker of both Mandarin and English, I am prepared to foster bridging communication and improve engagement across our diverse, multilingual constituents.

ARE YOU AWARE OF THE TIME COMMITMENT NECESSARY TO FULFILL THE OBLIGATIONS OF AN APPOINTMENT TO THIS POSITION?

YES  NO

NOTE: FOR LIBRARY BOARD OF TRUSTEE AND PLANNING COMMISSION APPLICATIONS ONLY  
STATE LAW AND THE CITY CONFLICT OF INTEREST CODE REQUIRES THAT LIBRARY BOARD OF TRUSTEE MEMBERS AND PLANNING COMMISSIONERS FILE A STATEMENT OF ECONOMIC INTERESTS (FORM 700) ANNUALLY AS WELL AS RELATED FORMS WHEN ASSUMING AND LEAVING OFFICE (e.g. sources of income, loans, gifts, investments, interest in real property as required by state law). DO YOU AGREE TO FILE ALL REQUIRED FORMS IN A TIMELY MANNER AS REQUIRED BY THE CITY'S FILING OFFICIAL?

YES  NO

---

**\*ARCADIA BEAUTIFUL APPLICANTS ONLY**

ARE YOU AWARE THAT THE PRIMARY FUNCTION OF THE ARCADIA BEAUTIFUL COMMISSION IS TO ACT AS JUDGES FOR THE COMMISSIONS AWARD PROGRAMS (Spring Home, Holiday Decoration, and Water Smart Hero awards)?

YES  NO

DO YOU HAVE THE ABILITY TO TRAVEL BY CAR DURING THE DAY AND IN THE EVENING FOR THE PURPOSE OF JUDGING?

YES  NO

THE ARCADIA BEAUTIFUL COMMISSION USUALLY HAS FOUR REGULAR MEETINGS EACH YEAR WITH ADDITIONAL MEETINGS AND/OR TIME COMMITMENTS SCHEDULED FOR THE PURPOSE OF CONDUCTING JUDGING FOR THE AWARD PROGRAMS, PARTICIPATING IN A 3-4 HOUR HOLIDAY DECORATION AWARD RECOGNITION EVENT, AND PARTICIPATING IN ARBOR DAY PROGRAMS. ADDITIONALLY, PRELIMINARY JUDGING FOR THE SPRING HOME AND HOLIDAY DECORATION AWARDS IS DONE WITH EACH COMMISSIONER TAKING RESPONSIBILITY FOR A SECTION OF THE CITY AND DRIVING THROUGH THE NEIGHBORHOODS TO SELECT THEIR NOMINATIONS FOR FINAL JUDGING BY THE COMMISSION. ARE YOU ABLE TO FULFILL THIS TIME COMMITMENT?

YES  NO

---

I HEREBY CERTIFY THAT THE FOREGOING INFORMATION IS TRUE AND CORRECT TO THE BEST OF MY KNOWLEDGE.

YUTING CHE

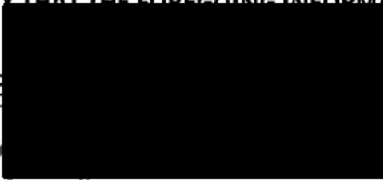

05/12/2026

DATE

NOTE: The City of Arcadia reserves the right to use the information provided on this application to verify your residential address and voter registration status. The information provided on this application is for internal use only and confidential information will not be released to the public.

PLEASE SUBMIT YOUR COMPLETED APPLICATION TO: CITY CLERK'S OFFICE  
240 W. HUNTINGTON DRIVE  
ARCADIA, CA 91007

OR

Email us at [CityClerk@ArcadiaCA.gov](mailto:CityClerk@ArcadiaCA.gov)



Questions? Please contact us at (626) 574-5455

SIERRA MADRE

MONROVIA

RWINDALE

TEMPLE CITY

-  Council Districts 2022
-  City Boundary

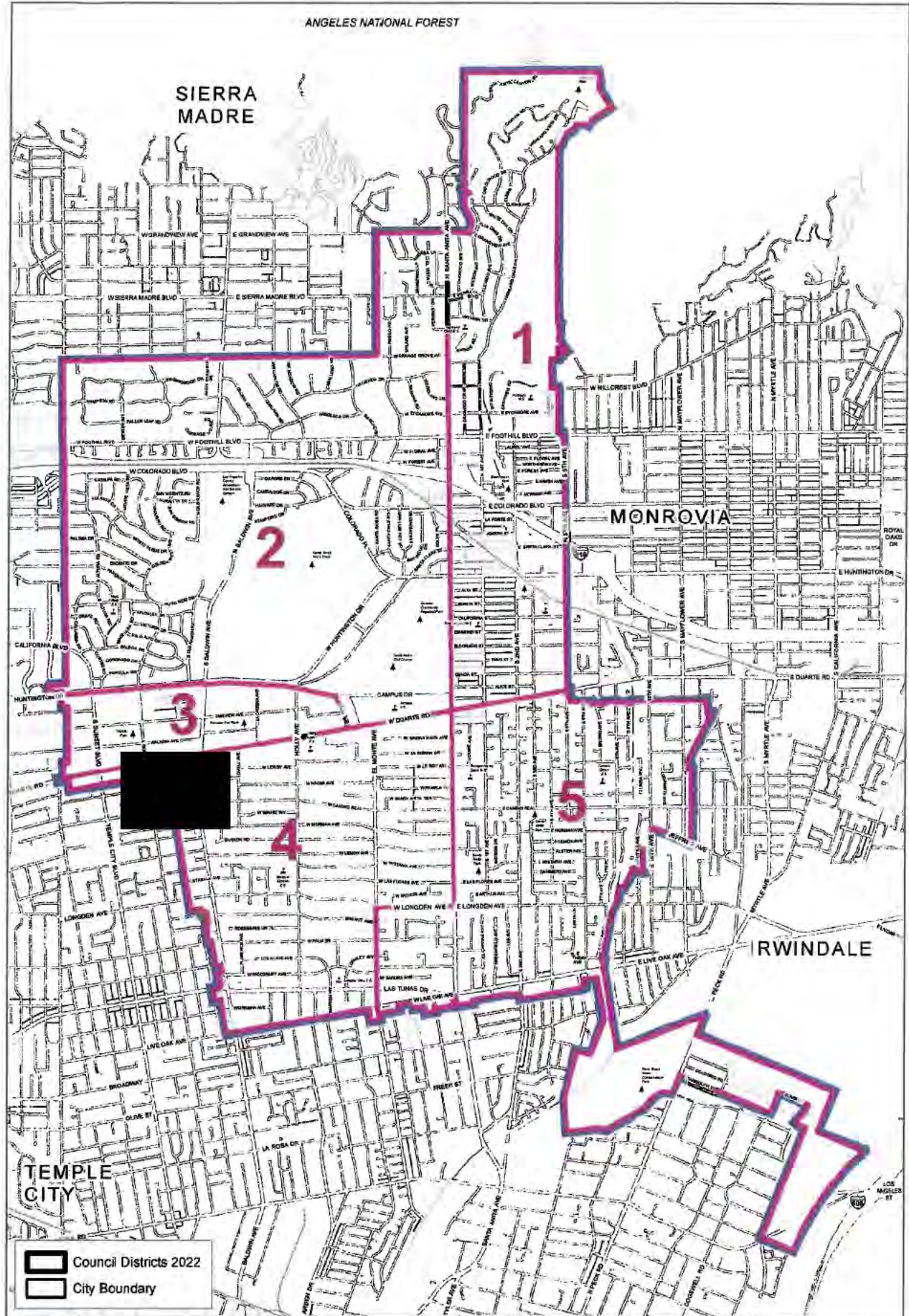

# Council District

## City of Arcadia, California

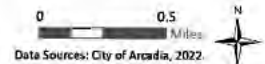



# City of Arcadia Board/Commission Application

RECEIVED

MAY 22 2026

PLEASE PLACE A CHECK MARK NEXT TO THE BOARD OR COMMISSION FOR WHICH YOU WOULD LIKE TO APPLY (more than one selection may be made):

- Arcadia Beautiful Commission\*
- Arcadia Museum Commission
- Human Resources Commission
- Library Board of Trustees
- Planning Commission
- Recreation and Parks Commission
- Senior Citizens Commission
- Arcadia Health Commission

NAME Jacqueline Huang DATE OF BIRTH (mm/dd/yyyy) [REDACTED]

FIRST LAST

RESIDENTIAL ADDRESS [REDACTED] Arcadia, CA 91007

(Note: Cannot be a mailing address or PO Box)

BUSINESS ADDRESS (HEALTH COMMISSION ONLY) \_\_\_\_\_

I CERTIFY THAT I AM A RESIDENT OF DISTRICT  ONE  TWO  THREE  FOUR  FIVE  
 N/A (Health Commission Only)

PHONE NUMBER [REDACTED] EMAIL ADDRESS [REDACTED]

OCCUPATION SVP, Business Strategy/Communications EMPLOYER Bank of America

ARE YOU AN ARCADIA REGISTERED VOTER?  YES  NO

HOW LONG HAVE YOU BEEN A RESIDENT? (If Applicable) 25 years

PLEASE ANSWER THE QUESTIONS BELOW. YOU MAY USE ADDITIONAL SHEETS OF PAPER AS NECESSARY.

### EDUCATION (Include professional or vocational licenses or certificates)

Harvard University, Master of Liberal Arts, Management  
University of Southern California, Bachelor of Arts, Journalism (2nd major: Political Science, minor: Business)  
Arcadia High School

### COMMUNITY INVOLVEMENT (List organization memberships and committee assignments)

City Year Los Angeles, Associates Board Member, 2025 - Present  
Bank of America Asian Leadership Network, COO/Communications Chair, 2021 - Present  
United Nations Association Young Professionals Chair and Marketing Communications Chair, 2010 - 2016  
Bowery Mission Kids With A Promise, Mentor, 2009 - 2012

### PLEASE DESCRIBE ANY BACKGROUND, TRAINING, OR INTERESTS THAT QUALIFY YOU AS AN APPOINTEE

I have extensive experience in business strategy and operations, program/project management, process improvement, event planning/execution, volunteer management, nonprofit operations/boards/fundraising, and marketing/public relations/communications (~20 years). I've built teams, councils and programs from the ground up, led high-performing teams, and executed community/volunteering events focused on financial literacy, cultural diversity and charitable giving.

### WHAT INTERESTS YOU ABOUT THE BOARD/COMMISSION YOU ARE APPLYING FOR?

I recently moved back to Arcadia after 15 years of living in New York City, excited to make an impact on Arcadia's history and positive reputation, knowing this likely my forever home. One of the things I loved about NYC was how Central Park served as everyone's back yard—a meeting place, a place of belonging, a place to appreciate nature and beauty. Now with two young children, I'd like to create that sense of community, camaraderie and belonging through Arcadia's parks, events and programs and do my part in civic engagement.

ARE YOU AWARE OF THE TIME COMMITMENT NECESSARY TO FULFILL THE OBLIGATIONS OF AN APPOINTMENT TO THIS POSITION?

YES  NO

NOTE: FOR LIBRARY BOARD OF TRUSTEE AND PLANNING COMMISSION APPLICATIONS ONLY  
STATE LAW AND THE CITY CONFLICT OF INTEREST CODE REQUIRES THAT LIBRARY BOARD OF TRUSTEE MEMBERS AND PLANNING COMMISSIONERS FILE A STATEMENT OF ECONOMIC INTERESTS (FORM 700) ANNUALLY AS WELL AS RELATED FORMS WHEN ASSUMING AND LEAVING OFFICE (e.g. sources of income, loans, gifts, investments, interest in real property as required by state law). DO YOU AGREE TO FILE ALL REQUIRED FORMS IN A TIMELY MANNER AS REQUIRED BY THE CITY'S FILING OFFICIAL?

YES  NO

---

**\*ARCADIA BEAUTIFUL APPLICANTS ONLY**

ARE YOU AWARE THAT THE PRIMARY FUNCTION OF THE ARCADIA BEAUTIFUL COMMISSION IS TO ACT AS JUDGES FOR THE COMMISSIONS AWARD PROGRAMS (Spring Home, Holiday Decoration, and Water Smart Hero awards)?

YES  NO

DO YOU HAVE THE ABILITY TO TRAVEL BY CAR DURING THE DAY AND IN THE EVENING FOR THE PURPOSE OF JUDGING?

YES  NO

THE ARCADIA BEAUTIFUL COMMISSION USUALLY HAS FOUR REGULAR MEETINGS EACH YEAR WITH ADDITIONAL MEETINGS AND/OR TIME COMMITMENTS SCHEDULED FOR THE PURPOSE OF CONDUCTING JUDGING FOR THE AWARD PROGRAMS, PARTICIPATING IN A 3-4 HOUR HOLIDAY DECORATION AWARD RECOGNITION EVENT, AND PARTICIPATING IN ARBOR DAY PROGRAMS. ADDITIONALLY, PRELIMINARY JUDGING FOR THE SPRING HOME AND HOLIDAY DECORATION AWARDS IS DONE WITH EACH COMMISSIONER TAKING RESPONSIBILITY FOR A SECTION OF THE CITY AND DRIVING THROUGH THE NEIGHBORHOODS TO SELECT THEIR NOMINATIONS FOR FINAL JUDGING BY THE COMMISSION. ARE YOU ABLE TO FULFILL THIS TIME COMMITMENT?

YES  NO

---

I HEREBY CERTIFY THAT THE FOREGOING INFORMATION IS TRUE AND CORRECT TO THE BEST OF MY KNOWLEDGE.



5/21/2026

DATE

NOTE: The City of Arcadia reserves the right to use the information provided on this application to verify your residential address and voter registration status. The information provided on this application is for internal use only and confidential information will not be released to the public.

PLEASE SUBMIT YOUR COMPLETED APPLICATION TO: CITY CLERK'S OFFICE  
240 W. HUNTINGTON DRIVE  
ARCADIA, CA 91007

OR

Email us at [CityClerk@ArcadiaCA.gov](mailto:CityClerk@ArcadiaCA.gov)

Questions? Please contact us at (626) 574-5455

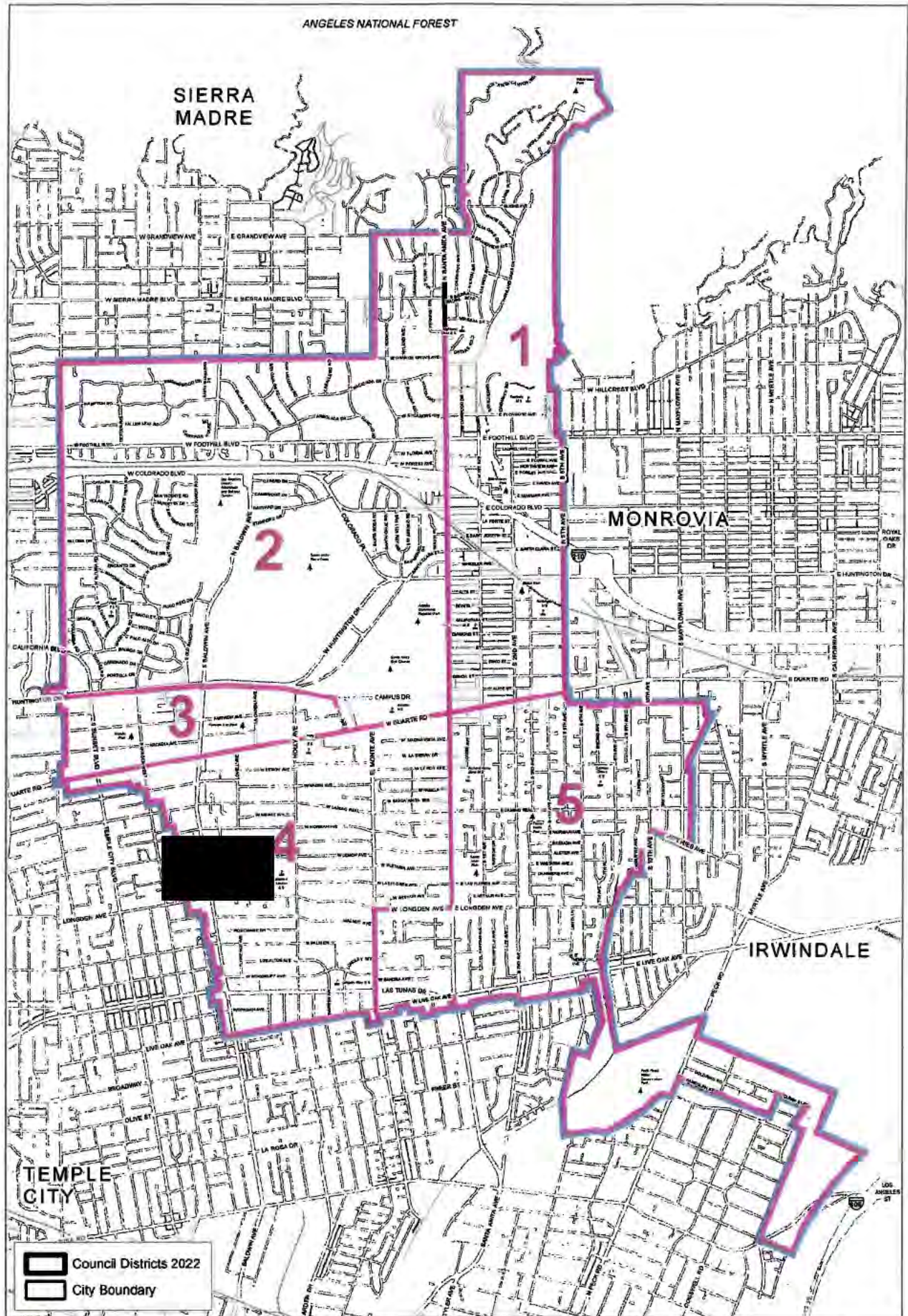

**Council District**  
**City of Arcadia, California**



RECEIVED

# City of Arcadia Board/Commission Application

MAY 26 2026

PLEASE PLACE A CHECK MARK NEXT TO THE BOARD OR COMMISSION FOR WHICH YOU WOULD LIKE TO APPLY. (more than one selection may be made):

CITY OF ARCADIA  
OFFICE

- Arcadia Beautiful Commission\*
- Arcadia Museum Commission
- Human Resources Commission
- Library Board of Trustees
- Planning Commission
- Recreation and Parks Commission
- Senior Citizens Commission
- Arcadia Health Commission

NAME Cris Arzate DATE OF BIRTH (mm/dd/yyyy) [REDACTED]

FIRST LAST

RESIDENTIAL ADDRESS [REDACTED] Arcadia Ca 91006

(Note: Cannot be a mailing address or PO Box)

BUSINESS ADDRESS (HEALTH COMMISSION ONLY) \_\_\_\_\_

I CERTIFY THAT I AM A RESIDENT OF DISTRICT  ONE  TWO  THREE  FOUR  FIVE  
 N/A (Health Commission Only)

PHONE NUMBER [REDACTED]

EMAIL ADDRESS [REDACTED]

OCCUPATION Affordable Housing/Community Affairs

EMPLOYER Housing Authority of the City of Los Angeles

ARE YOU AN ARCADIA REGISTERED VOTER?  YES  NO

HOW LONG HAVE YOU BEEN A RESIDENT? (If Applicable) 5

PLEASE ANSWER THE QUESTIONS BELOW YOU MAY USE ADDITIONAL SHEETS OF PAPER AS NECESSARY

**EDUCATION (Include professional or vocational licenses or certificates)**

BA U.C. Berkeley, MRED Georgetown University, Coro Fellow in Public Affairs, Harvard Graduate School of Education Management Development (Certificate), U.S.C. Ross Program in Real Estate Development and Finance (Certificate)

**COMMUNITY INVOLVEMENT (List organization memberships and committee assignments)**

Commissioner City of Arcadia, Senior Citizens Commission, Commissioner California Student Aid Commission, Board President California Structural Pest Control Board, Chair Los Angeles Unified School District Human Relations Commission.

**PLEASE DESCRIBE ANY BACKGROUND, TRAINING, OR INTERESTS THAT QUALIFY YOU AS AN APPOINTEE**

Twenty five years of experience in state and local governing boards with budgets ranging from \$10 million to \$1.5 Billion. Career in real estate (realtor, affordable housing and community affairs), extensive experience in public policy and government relations. Served as Executive Director of multiple non profits (youth and public safety) Raised over \$20 million in public, private individual and foundation funds for public and private projects.

**WHAT INTERESTS YOU ABOUT THE BOARD/COMMISSION YOU ARE APPLYING FOR?**

As a resident of Arcadia, I want to use my time, experience and resources to improve the quality of life for our residents and businesses. June is my last month on the Senior Citizens Commission, and it has provided a great deal of insight to the City and its residents and the staff that make Arcadia function at a very high level. My experience in real estate, economic development, public safety, digital equity and youth development serves as a lens that few bring to the Planning Commission. This holistic view, passion and vision enables me to provide thoughtful and insightful

ARE YOU AWARE OF THE TIME COMMITMENT NECESSARY TO FULFILL THE OBLIGATIONS OF AN APPOINTMENT TO THIS POSITION?

YES  NO

NOTE FOR LIBRARY BOARD OF TRUSTEE AND PLANNING COMMISSION APPLICATIONS ONLY  
STATE LAW AND THE CITY CONFLICT OF INTEREST CODE REQUIRES THAT LIBRARY BOARD OF TRUSTEE MEMBERS AND PLANNING COMMISSIONERS FILE A STATEMENT OF ECONOMIC INTERESTS (FORM 700) ANNUALLY AS WELL AS RELATED FORMS WHEN ASSUMING AND LEAVING OFFICE (e.g. sources of income, loans, gifts, investments, interest in real property as required by state law). DO YOU AGREE TO FILE ALL REQUIRED FORMS IN A TIMELY MANNER AS REQUIRED BY THE CITY'S FILING OFFICIAL?

YES  NO

**\*ARCADIA BEAUTIFUL APPLICANTS ONLY**

ARE YOU AWARE THAT THE PRIMARY FUNCTION OF THE ARCADIA BEAUTIFUL COMMISSION IS TO ACT AS JUDGES FOR THE COMMISSIONS AWARD PROGRAMS (Spring Home, Holiday Decoration, and Water Smart Hero awards)?

YES  NO

DO YOU HAVE THE ABILITY TO TRAVEL BY CAR DURING THE DAY AND IN THE EVENING FOR THE PURPOSE OF JUDGING?

YES  NO

THE ARCADIA BEAUTIFUL COMMISSION USUALLY HAS FOUR REGULAR MEETINGS EACH YEAR WITH ADDITIONAL MEETINGS AND/OR TIME COMMITMENTS SCHEDULED FOR THE PURPOSE OF CONDUCTING JUDGING FOR THE AWARD PROGRAMS, PARTICIPATING IN A 3-4 HOUR HOLIDAY DECORATION AWARD RECOGNITION EVENT, AND PARTICIPATING IN ARBOR DAY PROGRAMS. ADDITIONALLY, PRELIMINARY JUDGING FOR THE SPRING HOME AND HOLIDAY DECORATION AWARDS IS DONE WITH EACH COMMISSIONER TAKING RESPONSIBILITY FOR A SECTION OF THE CITY AND DRIVING THROUGH THE NEIGHBORHOODS TO SELECT THEIR NOMINATIONS FOR FINAL JUDGING BY THE COMMISSION. ARE YOU ABLE TO FULFILL THIS TIME COMMITMENT?

YES  NO

I HEREBY CERTIFY THAT THE FOREGOING INFORMATION IS TRUE AND CORRECT TO THE BEST OF MY KNOWLEDGE.

[Redacted Signature]

SIGNATURE

5/22/24

DATE

NOTE: The City of Arcadia reserves the right to use the information provided on this application to verify your residential address and voter registration status. The information provided on this application is for internal use only and confidential information will not be released to the public.

PLEASE SUBMIT YOUR COMPLETED APPLICATION TO: CITY CLERK'S OFFICE  
240 W. HUNTINGTON DRIVE  
ARCADIA, CA 91007

OR

Email us at [CityClerk@ArcadiaCA.gov](mailto:CityClerk@ArcadiaCA.gov)

Questions? Please contact us at (626) 574-5455

# *Cris Arzate*

[REDACTED] Arcadia, Ca 91006  
[REDACTED]

---

## **PROFESSIONAL EXPERIENCE**

## **POSITION**

### **Housing Authority of the City of Los Angeles**

### **Deputy Assistant Director**

January 2021 - Present

- Direct the strategy, management, assessment and resource development for all resident services for 18,250 residents in 6,120 units within all 12 public housing developments in our portfolio.
- Created and direct the Digital Equity Master Plan for HACLA, including policy analysis, advocacy, resource development to renovate 11 computer labs, and compliance with various private and public funding.
- Budget Management: Annually plan, administer and report expenditure of \$4.5 million in public funds, to service providers, consultants, and operations for delivery of services
- Partnership Development: Build new and manage existing relationships with external community-based organizations, public parties and private sector interests.
- Contract Management: Manage legal staff responsible for generating and amending contracts for our 120 different service providers. Generate and administer RFP's for service providers, contractors, and other professional services.
- Resource Development: Identify, solicit and secure resources for families, digital equity programs, scholarships and facilities. Supervise the reporting for publicly funded grants and communicate with private sector donors.
- Change Management: Counsel and support the transition of programs, budgets, staff, and facilities within HACLA and between HACLA and its philanthropic arm Build Hope Inc.
- Community Engagement: Collaborate with Resident Advisory Councils (RACs), and local stakeholders to address resident concerns, represent their interests, and cultivate an improved living environment.
- Capital Improvement: Project manage and raise capital for computer lab renovations at public housing sites. Supervision of architect, contractor, in collaboration with legal for licensing agreement to renovate. Identify, solicit and secure funding for equipment, staff and training for digital equity programs within the facilities.
- Data Management: Developed online reporting system for all resident service providers (licensees). The platform maintains records to assess effectiveness and inform improvements.

### **TWELVE Co.: A Public Affairs Consultancy**

### **Principal**

June 2015 - Present

- Provide executive consulting services to non-profit organizations, foundations, affordable housing developers, and small businesses.
- Organize advocacy campaigns throughout California to support the advancement of public policy in education, affordable housing, technology, and economic development.
- Secured \$6 million for affordable housing developers on complex public finance opportunities.
- Provide professional development to constituent groups: board members, staff, and volunteers.

### **Variety Boys and Girls Club**

### **Executive Director**

July 2011 – June 2015

- Identified, solicited, authored proposals and successfully raised over \$5,000,000 in foundation, corporate, and individual funds to operate the organization.
- Diversified board of directors from 12 to 25 to change the culture, staff and programming to college readiness.
- Developed the organizations first 5-year strategic plan, updated HR policies and procedures, employee handbook, and orientations.
- Administered the operations of two sites of the organization with a 25-member board of directors and a staff of 35.
- Led annual fundraising events including annual gala, golf tournament, giving campaign.
- Solicited and organized an annual scholarship program that annually awarded over \$100,000.

**One-Economy Corporation**

**Director - California**

January 2008 to July 2011

- Directed the strategy and implementation a statewide \$2 million, technology-based community development grant funded program in 10 rural and urban California communities.
- Cultivated, evaluated and selected public-private partnerships throughout California to connect 10,000+ low-income housing units to the internet, secured over \$1 million in technology resources, employed 125 youth and adults, acquired hardware and created content tailored to the specific community.
- Directed staff of 8 to implement resources and programmatic activities.
- Chaired 3 regional executive level community advisory boards and authored 10 technology based Digital Inclusion plans for 10 low-income urban and rural communities in California.

**Southern New Hampshire University**

**Consultant**

July 2006 to March 2008

- Created the West Coast Center of the Southern New Hampshire University (SNHU), Master of Science in Community Economic Development.
- Developed marketing and strategic partnership strategies to introduce SNHU to Southern California stakeholders.
- Identified, evaluated, and admitted professionals into the program with a 95% retention rate upon graduation.
- Recruited local professors to administer the inaugural class and their respective coursework.
- Oriented students on financial aid programs, on-line assistance, and programs expectations.

**Los Angeles Trade-Technical Community College**

**Advisor to the President / Director**

August 2001 – July 2006

- Secured and administered \$1.8 million in grants: small business, workforce development, and technology.
- Directed the Non-Credit Department and established over 15 community based and institutional partnerships to deliver free entry level courses throughout South L.A., Pico Union, MacArthur Park, Boyle Heights, and East Los Angeles
- Acted on behalf of the President on external relations and institutional advancement as a public relations liaison for the college
- Drafted all external and internal LATTC publications on behalf of the President.
- Identified, hired, and supervised approximately 40 faculty to implement state and federally funded courses.
- Created the LATTC Resource Development Office.

**EDUCATION, PROFESSIONAL DEVELOPMENT, LICENSE & APPOINTMENTS**

**Georgetown University**

Masters, Real Estate Development

**University of California, Berkeley**

Bachelor's, Political Science

**Harvard Graduate School of Education**

Management Development Program

**University of Southern California**

Real Estate Finance & Development

**Coro Fellows Program in Public Affairs**

Fellowship

**Annenberg Foundation**

Alchemy PLUS Leadership Series

**The Center for Non-Profit Management**

Non-Profit Leadership Dev. Program

**California Department of Real Estate**

Real Estate Salesperson

**APPOINTMENTS**

**California Student Aid Commission**

Commissioner (Secretary)

**California Dept. of Consumer Affairs**

Board Member (President)

**City of Arcadia: Senior Citizens Commission**

Commissioner

**L.A.U.S.D: Human Relations Commission**

Commissioner (Chair)

SIERRA MADRE

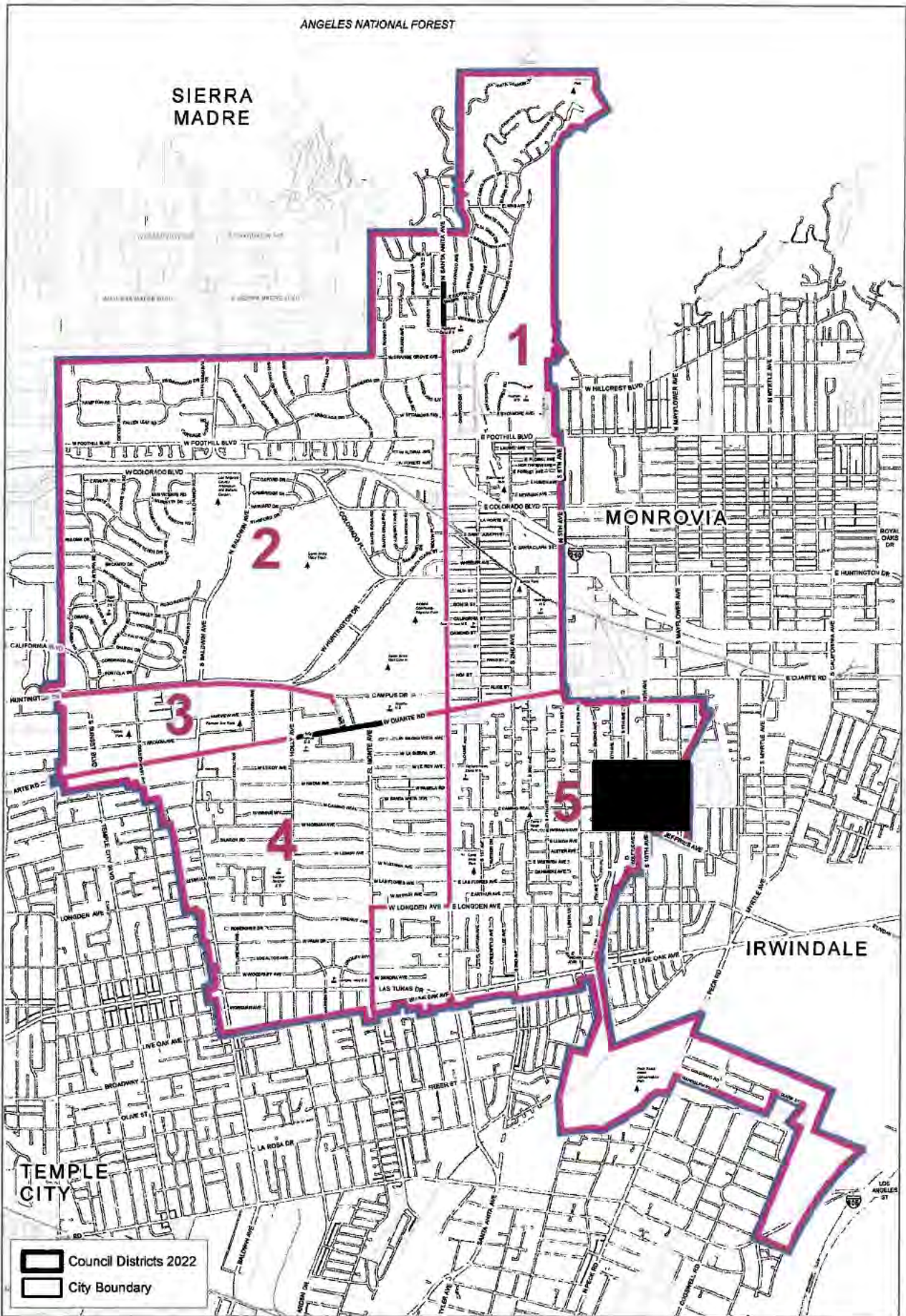

**Council District**  
*City of Arcadia, California*

# **SENIOR CITIZENS COMMISSION APPLICANTS**



# City of Arcadia Board/Commission Application

PLEASE PLACE A CHECK MARK NEXT TO THE BOARD OR COMMISSION FOR WHICH YOU WOULD LIKE TO APPLY (more than one selection may be made):

- |  |  |
|--|--|
| <input type="checkbox"/> Arcadia Beautiful Commission* | <input type="checkbox"/> Planning Commission                   |
| <input type="checkbox"/> Arcadia Museum Commission     | <input type="checkbox"/> Recreation and Parks Commission       |
| <input type="checkbox"/> Human Resources Commission    | <input checked="" type="checkbox"/> Senior Citizens Commission |
| <input type="checkbox"/> Library Board of Trustees     | <input type="checkbox"/> Arcadia Health Commission             |

NAME Douglas Meyer DATE OF BIRTH (mm/dd/yyyy) [REDACTED]

FIRST LAST

RESIDENTIAL ADDRESS [REDACTED] Arcadia, California 91007

(Note: Cannot be a mailing address or PO Box)

BUSINESS ADDRESS (HEALTH COMMISSION ONLY) \_\_\_\_\_

I CERTIFY THAT I AM A RESIDENT OF DISTRICT  ONE  TWO  THREE  FOUR  FIVE  
 N/A (Health Commission Only)

PHONE NUMBER [REDACTED] EMAIL ADDRESS [REDACTED]

OCCUPATION Real Estate Broker EMPLOYER Coldwell Banker Realty

ARE YOU AN ARCADIA REGISTERED VOTER?  YES  NO

HOW LONG HAVE YOU BEEN A RESIDENT? (If Applicable) 28 years

PLEASE ANSWER THE QUESTIONS BELOW. YOU MAY USE ADDITIONAL SHEETS OF PAPER AS NECESSARY

EDUCATION (Include professional or vocational licenses or certificates)

*REAL ESTATE BROKERS LICENSE FOR OVER 50 YEARS  
FINISH 2 YEARS OF COLLEGE*

COMMUNITY INVOLVEMENT (List organization memberships and committee assignments)

*ON A HOA BOARD IN ARCADIA NOW*

PLEASE DESCRIBE ANY BACKGROUND, TRAINING, OR INTERESTS THAT QUALIFY YOU AS AN APPOINTEE

*BEING A SENIOR MYSELF I LOOK FOR TO  
HELPING MY COMMUNITY AND ARCADIA SENIORS*

WHAT INTERESTS YOU ABOUT THE BOARD/COMMISSION YOU ARE APPLYING FOR?

*I DESIRE TO SERVE MY COMMUNITY*

RECEIVED  
CITY OF ARCADIA  
MAR 09 2026  
CITY MANAGER

ARE YOU AWARE OF THE TIME COMMITMENT NECESSARY TO FULFILL THE OBLIGATIONS OF AN APPOINTMENT TO THIS POSITION?

YES  NO

NOTE: FOR LIBRARY BOARD OF TRUSTEE AND PLANNING COMMISSION APPLICATIONS ONLY  
STATE LAW AND THE CITY CONFLICT OF INTEREST CODE REQUIRES THAT LIBRARY BOARD OF TRUSTEE MEMBERS AND PLANNING COMMISSIONERS FILE A STATEMENT OF ECONOMIC INTERESTS (FORM 700) ANNUALLY AS WELL AS RELATED FORMS WHEN ASSUMING AND LEAVING OFFICE (e.g. sources of income, loans, gifts, investments, interest in real property as required by state law). DO YOU AGREE TO FILE ALL REQUIRED FORMS IN A TIMELY MANNER AS REQUIRED BY THE CITY'S FILING OFFICIAL?

YES  NO

---

**\*ARCADIA BEAUTIFUL APPLICANTS ONLY**

ARE YOU AWARE THAT THE PRIMARY FUNCTION OF THE ARCADIA BEAUTIFUL COMMISSION IS TO ACT AS JUDGES FOR THE COMMISSIONS AWARD PROGRAMS (Spring Home, Holiday Decoration, and Water Smart Hero awards)?

YES  NO

DO YOU HAVE THE ABILITY TO TRAVEL BY CAR DURING THE DAY AND IN THE EVENING FOR THE PURPOSE OF JUDGING?

YES  NO

THE ARCADIA BEAUTIFUL COMMISSION USUALLY HAS FOUR REGULAR MEETINGS EACH YEAR WITH ADDITIONAL MEETINGS AND/OR TIME COMMITMENTS SCHEDULED FOR THE PURPOSE OF CONDUCTING JUDGING FOR THE AWARD PROGRAMS, PARTICIPATING IN A 3-4 HOUR HOLIDAY DECORATION AWARD RECOGNITION EVENT, AND PARTICIPATING IN ARBOR DAY PROGRAMS. ADDITIONALLY, PRELIMINARY JUDGING FOR THE SPRING HOME AND HOLIDAY DECORATION AWARDS IS DONE WITH EACH COMMISSIONER TAKING RESPONSIBILITY FOR A SECTION OF THE CITY AND DRIVING THROUGH THE NEIGHBORHOODS TO SELECT THEIR NOMINATIONS FOR FINAL JUDGING BY THE COMMISSION. ARE YOU ABLE TO FULFILL THIS TIME COMMITMENT?

YES  NO

---

I HEREBY CERTIFY THAT THE FOREGOING INFORMATION IS TRUE AND CORRECT TO THE BEST OF MY KNOWLEDGE.



3-1-26

DATE

NOTE: The City of Arcadia reserves the right to use the information provided on this application to verify your residential address and voter registration status. The information provided on this application is for internal use only and confidential information will not be released to the public.

PLEASE SUBMIT YOUR COMPLETED APPLICATION TO: CITY CLERK'S OFFICE  
240 W. HUNTINGTON DRIVE  
ARCADIA, CA 91007

OR

Email us at [CityClerk@ArcadiaCA.gov](mailto:CityClerk@ArcadiaCA.gov)

Questions? Please contact us at (626) 574-5455

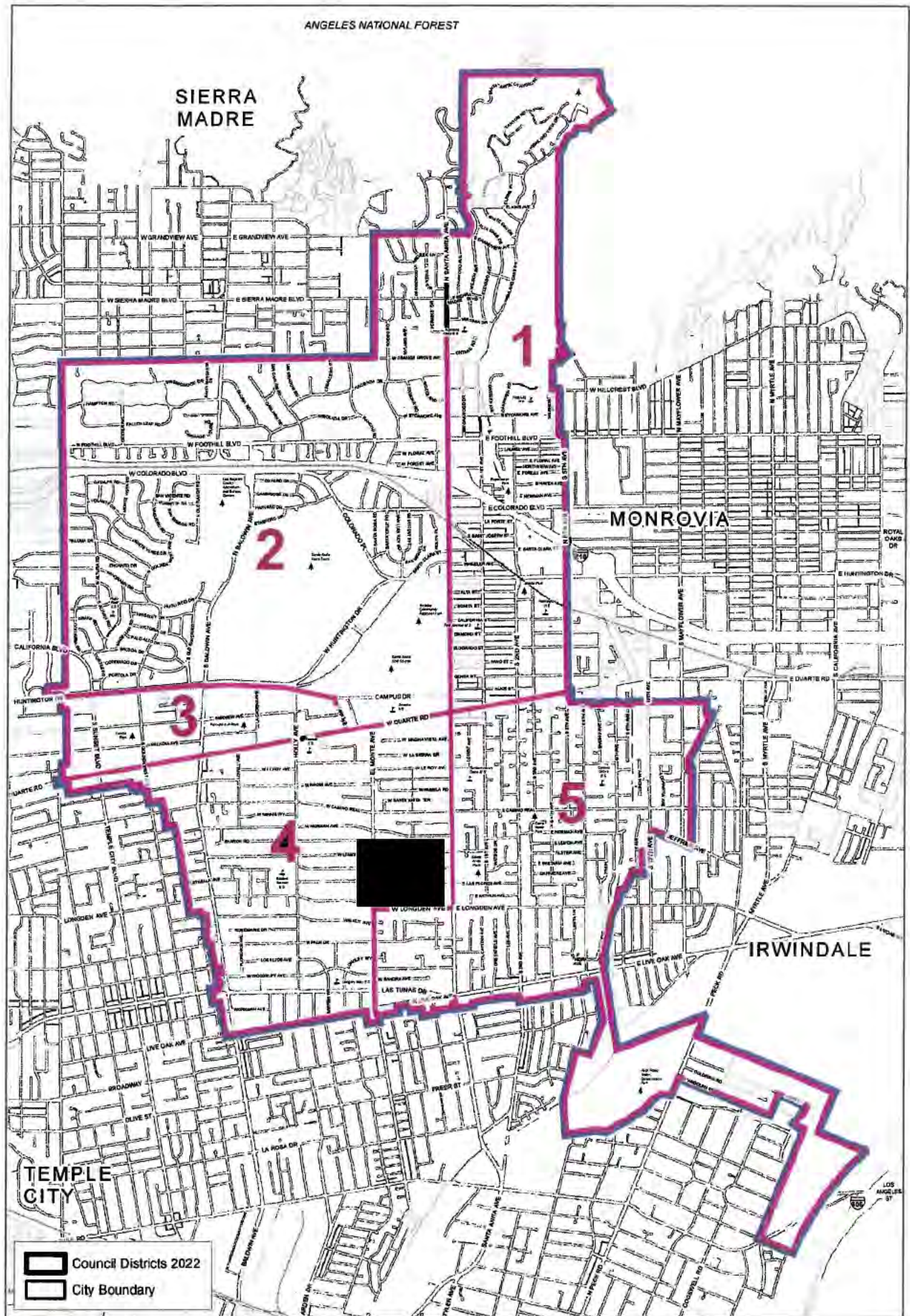

**Council District**  
 City of Arcadia, California



# City of Arcadia Board/Commission Application

RECEIVED  
CITY OF ARCADIA

MAR 16 2026

CITY MANAGER

PLEASE PLACE A CHECK MARK NEXT TO THE BOARD OR COMMISSION FOR WHICH YOU WOULD LIKE TO APPLY (more than one selection may be made):

- |   |   |
|---|---|
| <input checked="" type="checkbox"/> Arcadia Beautiful Commission* | <input checked="" type="checkbox"/> Planning Commission             |
| <input type="checkbox"/> Arcadia Museum Commission                | <input checked="" type="checkbox"/> Recreation and Parks Commission |
| <input checked="" type="checkbox"/> Human Resources Commission    | <input checked="" type="checkbox"/> Senior Citizens Commission      |
| <input checked="" type="checkbox"/> Library Board of Trustees     | <input type="checkbox"/> Arcadia Health Commission                  |

NAME JOHNNY TSENG DATE OF BIRTH (mm/dd/yyyy) [REDACTED]

FIRST LAST

RESIDENTIAL ADDRESS [REDACTED] 91006

(Note: Cannot be a mailing address or PO Box)

BUSINESS ADDRESS (HEALTH COMMISSION ONLY) \_\_\_\_\_

I CERTIFY THAT I AM A RESIDENT OF DISTRICT  ONE  TWO  THREE  FOUR  FIVE  
 N/A (Health Commission Only)

PHONE NUMBER [REDACTED] EMAIL ADDRESS [REDACTED]

OCCUPATION Teacher EMPLOYER Hacienda La Puente Unified School District

ARE YOU AN ARCADIA REGISTERED VOTER?  YES  NO

HOW LONG HAVE YOU BEEN A RESIDENT? (If Applicable) 19

PLEASE ANSWER THE QUESTIONS BELOW. YOU MAY USE ADDITIONAL SHEETS OF PAPER AS NECESSARY.

**EDUCATION (Include professional or vocational licenses or certificates)**

Active Community Member, Interest in community service, betterment of the City of Arcadia, and highly enthusiastic and involved. Would be amazing to have this opportunity to make a difference.

**COMMUNITY INVOLVEMENT (List organization memberships and committee assignments)**

Active Community Member, Interest in community service, betterment of the City of Arcadia, and highly enthusiastic and involved. Would be amazing to have this opportunity to make a difference.

**PLEASE DESCRIBE ANY BACKGROUND, TRAINING, OR INTERESTS THAT QUALIFY YOU AS AN APPOINTEE**

Active Community Member, Interest in community service, betterment of the City of Arcadia, and highly enthusiastic and involved. Would be amazing to have this opportunity to make a difference.

**WHAT INTERESTS YOU ABOUT THE BOARD/COMMISSION YOU ARE APPLYING FOR?**

Active Community Member, Interest in community service, betterment of the City of Arcadia, and highly enthusiastic and involved. Would be amazing to have this opportunity to make a difference.

ARE YOU AWARE OF THE TIME COMMITMENT NECESSARY TO FULFILL THE OBLIGATIONS OF AN APPOINTMENT TO THIS POSITION?

YES  NO

NOTE: FOR LIBRARY BOARD OF TRUSTEE AND PLANNING COMMISSION APPLICATIONS ONLY  
STATE LAW AND THE CITY CONFLICT OF INTEREST CODE REQUIRES THAT LIBRARY BOARD OF TRUSTEE MEMBERS AND PLANNING COMMISSIONERS FILE A STATEMENT OF ECONOMIC INTERESTS (FORM 700) ANNUALLY AS WELL AS RELATED FORMS WHEN ASSUMING AND LEAVING OFFICE (e.g. sources of income, loans, gifts, investments, interest in real property as required by state law). DO YOU AGREE TO FILE ALL REQUIRED FORMS IN A TIMELY MANNER AS REQUIRED BY THE CITY'S FILING OFFICIAL?

YES  NO

---

**\*ARCADIA BEAUTIFUL APPLICANTS ONLY**

ARE YOU AWARE THAT THE PRIMARY FUNCTION OF THE ARCADIA BEAUTIFUL COMMISSION IS TO ACT AS JUDGES FOR THE COMMISSIONS AWARD PROGRAMS (Spring Home, Holiday Decoration, and Water Smart Hero awards)?

YES  NO

DO YOU HAVE THE ABILITY TO TRAVEL BY CAR DURING THE DAY AND IN THE EVENING FOR THE PURPOSE OF JUDGING?

YES  NO

THE ARCADIA BEAUTIFUL COMMISSION USUALLY HAS FOUR REGULAR MEETINGS EACH YEAR WITH ADDITIONAL MEETINGS AND/OR TIME COMMITMENTS SCHEDULED FOR THE PURPOSE OF CONDUCTING JUDGING FOR THE AWARD PROGRAMS, PARTICIPATING IN A 3-4 HOUR HOLIDAY DECORATION AWARD RECOGNITION EVENT, AND PARTICIPATING IN ARBOR DAY PROGRAMS. ADDITIONALLY, PRELIMINARY JUDGING FOR THE SPRING HOME AND HOLIDAY DECORATION AWARDS IS DONE WITH EACH COMMISSIONER TAKING RESPONSIBILITY FOR A SECTION OF THE CITY AND DRIVING THROUGH THE NEIGHBORHOODS TO SELECT THEIR NOMINATIONS FOR FINAL JUDGING BY THE COMMISSION. ARE YOU ABLE TO FULFILL THIS TIME COMMITMENT?

YES  NO

---

I HEREBY CERTIFY THAT THE INFORMATION IS TRUE AND CORRECT TO THE BEST OF MY KNOWLEDGE.



3-6-26  
DATE

NOTE: The City of Arcadia reserves the right to use the information provided on this application to verify your residential address and voter registration status. The information provided on this application is for internal use only and confidential information will not be released to the public.

PLEASE SUBMIT YOUR COMPLETED APPLICATION TO: CITY CLERK'S OFFICE  
240 W. HUNTINGTON DRIVE  
ARCADIA, CA 91007

OR

Email us at [CityClerk@ArcadiaCA.gov](mailto:CityClerk@ArcadiaCA.gov)

Questions? Please contact us at (626) 574-5455

CITY CLERK'S OFFICE  
240 W. HUNTINGTON DRIVE ARCADIA, CA 91007

City Clerk's Office  
City of Arcadia  
P. O. Box 60021  
Arcadia, California 91066

Masters in Arts- Educational Leadership  
Bachelor's in Arts- Child Development

**Arcadia High School Orchestra Benefit Dinner Committee Chair, San Marino Chinese School Board Member, AHS Hispanic Parent Booster Club Vice President, Arcadia Troop 104/333 Assistant Scout Master, Arcadia Citizens Oversight Committee Member. Arcadia Neighborhood Watch Captain**

**Active Community Member, Interest in community service, betterment of the City of Arcadia, and highly enthusiastic and involved. Would be amazing to have this opportunity to make a difference.**

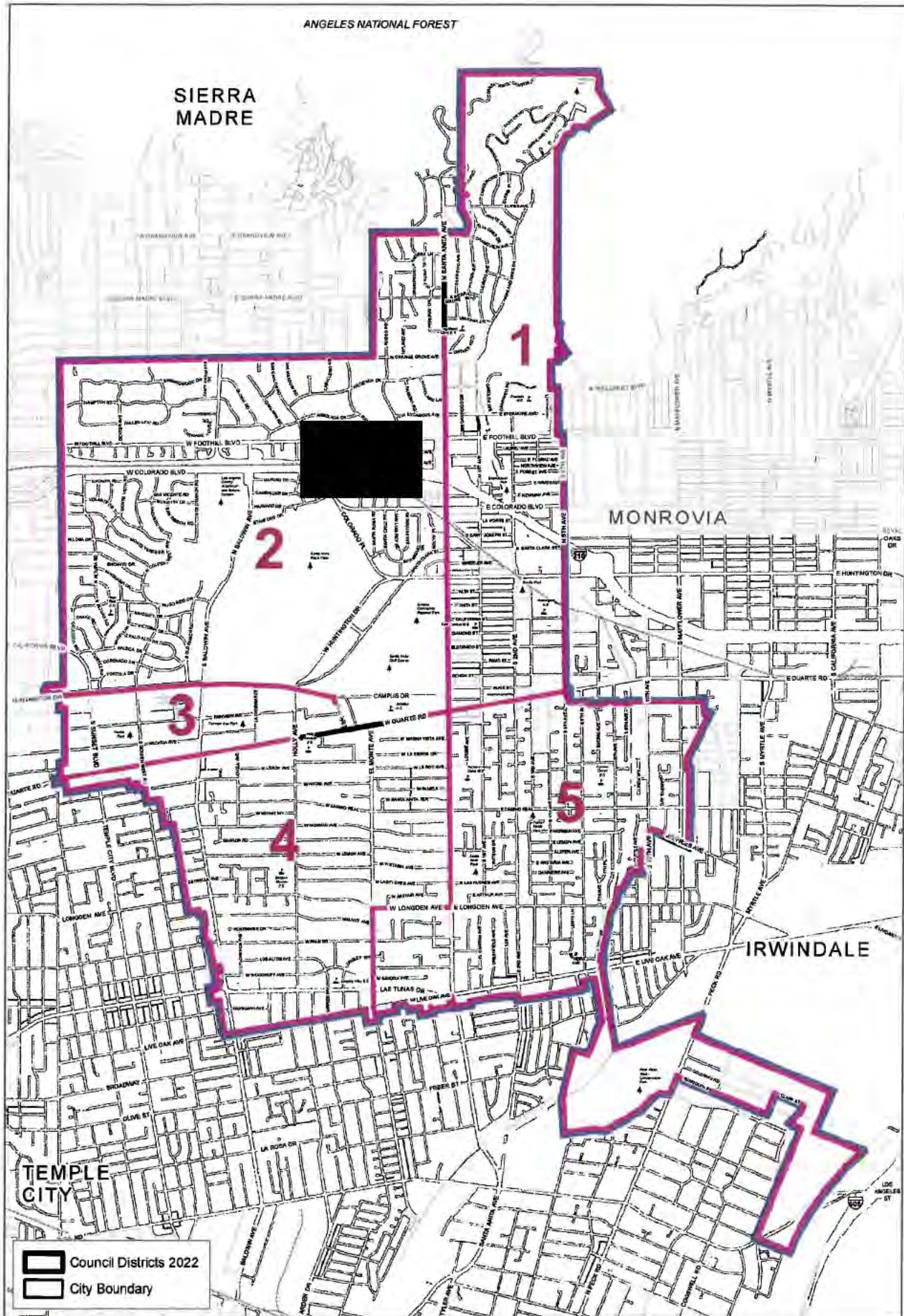

SIERRA MADRE



TEMPLE CITY

MONROVIA

IRWINDALE

 Council Districts 2022  
 City Boundary



# City of Arcadia Board/Commission Application

RECEIVED  
CITY OF ARCADIA

APR 13 2026  
CITY MANAGER

PLEASE PLACE A CHECK MARK NEXT TO THE BOARD OR COMMISSION FOR WHICH YOU WOULD LIKE TO APPLY (more than one selection may be made):

- |  |  |
|--|--|
| <input type="checkbox"/> Arcadia Beautiful Commission* | <input type="checkbox"/> Planning Commission                   |
| <input type="checkbox"/> Arcadia Museum Commission     | <input type="checkbox"/> Recreation and Parks Commission       |
| <input type="checkbox"/> Human Resources Commission    | <input checked="" type="checkbox"/> Senior Citizens Commission |
| <input type="checkbox"/> Library Board of Trustees     | <input type="checkbox"/> Arcadia Health Commission             |

NAME Angela Lai DATE OF BIRTH (mm/dd/yyyy) [REDACTED]  
FIRST LAST

RESIDENTIAL ADDRESS [REDACTED] Arcadia, CA 91007  
(Note: Cannot be a mailing address or PO Box)

BUSINESS ADDRESS (HEALTH COMMISSION ONLY) \_\_\_\_\_

I CERTIFY THAT I AM A RESIDENT OF DISTRICT  ONE  TWO  THREE  FOUR  FIVE  
 N/A (Health Commission Only)

PHONE NUMBER [REDACTED] EMAIL ADDRESS [REDACTED]

OCCUPATION community leader and retiree EMPLOYER N/A

ARE YOU AN ARCADIA REGISTERED VOTER?  YES  NO

HOW LONG HAVE YOU BEEN A RESIDENT? (If Applicable) 26 years

PLEASE ANSWER THE QUESTIONS BELOW. YOU MAY USE ADDITIONAL SHEETS OF PAPER AS NECESSARY.

**EDUCATION (Include professional or vocational licenses or certificates)**  
B.S. from Chinese Culture University, Taipei, Taiwan

**COMMUNITY INVOLVEMENT (List organization memberships and committee assignments)**  
- Senior Adviser of the Overseas Community Affairs Council for the Republic of China, Taiwan (2025-2027)  
- American Chinese Dance Association, President (1996, 2017, 2023-2025)  
- Chinese Culture University Alumni Association of Southern California, President (2025-2027)  
- Chinese American Citizens Alliance Greater San Gabriel Chapter, Director

**PLEASE DESCRIBE ANY BACKGROUND, TRAINING, OR INTERESTS THAT QUALIFY YOU AS AN APPOINTEE**  
Bringing over 50 years of experience in performing and teaching dance, as well as organizing dance performances and arts programming throughout Southern California and Taiwan in schools, performing arts centers, community events, parades, and concerts. Students have performed over 500 times in the US, Europe, and Asia. Taught at Chinese Culture University for 16 years and also at East Los Angeles College and UCLA. Represented Taiwan at the 1968 Olympics in Mexico and the 1970 World's Fair in Japan.

**WHAT INTERESTS YOU ABOUT THE BOARD/COMMISSION YOU ARE APPLYING FOR?**  
I believe I can be a valuable Senior Citizen Commissioner by using experience in performing arts and cultural programming to develop engaging initiatives and events that promote health, movement, and community engagement. With decades of experience coordinating community-based performances and educational programs, I am passionate about dedicating my time and effort to creating meaningful opportunities that promote connection, wellness, and joy for the senior community. I can create programming for Zumba, Line Dancing, Chinese Dance, Chinese Brush Painting, Karaoke and more.

ARE YOU AWARE OF THE TIME COMMITMENT NECESSARY TO FULFILL THE OBLIGATIONS OF AN APPOINTMENT TO THIS POSITION?

YES  NO

NOTE: FOR LIBRARY BOARD OF TRUSTEE AND PLANNING COMMISSION APPLICATIONS ONLY  
STATE LAW AND THE CITY CONFLICT OF INTEREST CODE REQUIRES THAT LIBRARY BOARD OF TRUSTEE MEMBERS AND PLANNING COMMISSIONERS FILE A STATEMENT OF ECONOMIC INTERESTS (FORM 700) ANNUALLY AS WELL AS RELATED FORMS WHEN ASSUMING AND LEAVING OFFICE (e.g. sources of income, loans, gifts, investments, interest in real property as required by state law). DO YOU AGREE TO FILE ALL REQUIRED FORMS IN A TIMELY MANNER AS REQUIRED BY THE CITY'S FILING OFFICIAL?

YES  NO

---

**\*ARCADIA BEAUTIFUL APPLICANTS ONLY**

ARE YOU AWARE THAT THE PRIMARY FUNCTION OF THE ARCADIA BEAUTIFUL COMMISSION IS TO ACT AS JUDGES FOR THE COMMISSIONS AWARD PROGRAMS (Spring Home, Holiday Decoration, and Water Smart Hero awards)?

YES  NO

DO YOU HAVE THE ABILITY TO TRAVEL BY CAR DURING THE DAY AND IN THE EVENING FOR THE PURPOSE OF JUDGING?

YES  NO

THE ARCADIA BEAUTIFUL COMMISSION USUALLY HAS FOUR REGULAR MEETINGS EACH YEAR WITH ADDITIONAL MEETINGS AND/OR TIME COMMITMENTS SCHEDULED FOR THE PURPOSE OF CONDUCTING JUDGING FOR THE AWARD PROGRAMS, PARTICIPATING IN A 3-4 HOUR HOLIDAY DECORATION AWARD RECOGNITION EVENT, AND PARTICIPATING IN ARBOR DAY PROGRAMS. ADDITIONALLY, PRELIMINARY JUDGING FOR THE SPRING HOME AND HOLIDAY DECORATION AWARDS IS DONE WITH EACH COMMISSIONER TAKING RESPONSIBILITY FOR A SECTION OF THE CITY AND DRIVING THROUGH THE NEIGHBORHOODS TO SELECT THEIR NOMINATIONS FOR FINAL JUDGING BY THE COMMISSION. ARE YOU ABLE TO FULFILL THIS TIME COMMITMENT?

YES  NO

---

I HEREBY CERTIFY THAT THE FOREGOING INFORMATION IS TRUE AND CORRECT TO THE BEST OF MY KNOWLEDGE.

April 8, 2026

DATE

NOTE: The City of Arcadia reserves the right to use the information provided on this application to verify your residential address and voter registration status. The information provided on this application is for internal use only and confidential information will not be released to the public.

PLEASE SUBMIT YOUR COMPLETED APPLICATION TO: CITY CLERK'S OFFICE  
240 W. HUNTINGTON DRIVE  
ARCADIA, CA 91007

OR

Email us at [CityClerk@ArcadiaCA.gov](mailto:CityClerk@ArcadiaCA.gov)



Questions? Please contact us at (626) 574-5455

SIERRA MADRE

MONROVIA

IRWINDALE

TEMPLE CITY

 Council Districts 2022  
 City Boundary

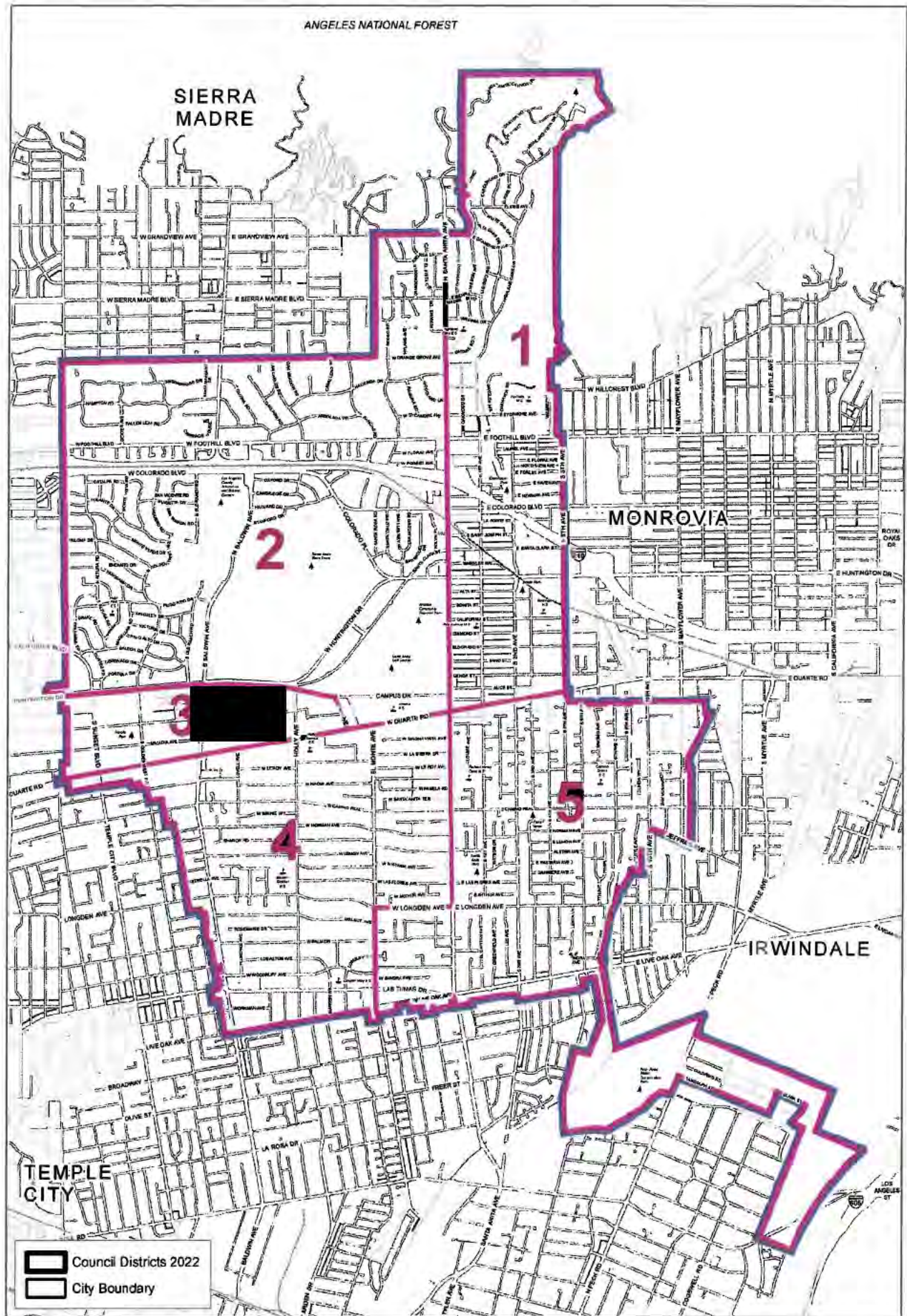



# City of Arcadia Board/Commission Application

RECEIVED

APR 15 2026

PLEASE PLACE A CHECK MARK NEXT TO THE BOARD OR COMMISSION FOR WHICH YOU WOULD LIKE TO APPLY (more than one selection may be made):

JOVAPPEL@ARCADIA  
CITY CLERK

- |  |  |
|--|--|
| <input type="checkbox"/> Arcadia Beautiful Commission* | <input type="checkbox"/> Planning Commission                   |
| <input type="checkbox"/> Arcadia Museum Commission     | <input type="checkbox"/> Recreation and Parks Commission       |
| <input type="checkbox"/> Human Resources Commission    | <input checked="" type="checkbox"/> Senior Citizens Commission |
| <input type="checkbox"/> Library Board of Trustees     | <input type="checkbox"/> Arcadia Health Commission             |

NAME Azar Dabiri DATE OF BIRTH (mm/dd/yyyy) [REDACTED]

FIRST LAST

RESIDENTIAL ADDRESS [REDACTED] Arcadia Ca 91007

(Note: Cannot be a mailing address or PO Box)

BUSINESS ADDRESS (HEALTH COMMISSION ONLY) \_\_\_\_\_

I CERTIFY THAT I AM A RESIDENT OF DISTRICT  ONE  TWO  THREE  FOUR  FIVE  
 N/A (Health Commission Only)

PHONE NUMBER [REDACTED] EMAIL ADDRESS [REDACTED]

OCCUPATION Retired Engineer EMPLOYER SCAQMD

ARE YOU AN ARCADIA REGISTERED VOTER?  YES  NO

HOW LONG HAVE YOU BEEN A RESIDENT? (If Applicable) 30 years

PLEASE ANSWER THE QUESTIONS BELOW. YOU MAY USE ADDITIONAL SHEETS OF PAPER AS NECESSARY.

### EDUCATION (Include professional or vocational licenses or certificates)

MS in Chemical / Petroleum Engineering

### COMMUNITY INVOLVEMENT (List organization memberships and committee assignments)

Served as volunteers at AHS, First Ave Middle School, Baldwin Stocker, Boy Scouts of America. Served as a judge for Southern California Engineering and Science Fair in 2026. Member of Toast Master Club for 16 years (served in different roles)

### PLEASE DESCRIBE ANY BACKGROUND, TRAINING, OR INTERESTS THAT QUALIFY YOU AS AN APPOINTEE

As a manager, had the responsibility to review, study and make recommendations on issuing the permits to operate for different industrial equipment such as gas stations, autobody shops, dry cleaners and different manufacturing operations. These reviews required comprehensive analyses of the projects, verifying if they are in compliance with local, state and federal rules and regulations.

### WHAT INTERESTS YOU ABOUT THE BOARD/COMMISSION YOU ARE APPLYING FOR?

As a senior resident of Arcadia for 30 years with my family, and raising our two sons, I am interested to get involved in services, activities, and issues impacting Arcadia's senior population. Since I have worked both at the private sector and government agency at different capacities, I am interested in using my experience at this assignment. Also I like to learn more about our city, related legislations, and be active in the community, and support the senior citizens.

ARE YOU AWARE OF THE TIME COMMITMENT NECESSARY TO FULFILL THE OBLIGATIONS OF AN APPOINTMENT TO THIS POSITION?

YES  NO

NOTE: FOR LIBRARY BOARD OF TRUSTEE AND PLANNING COMMISSION APPLICATIONS ONLY  
STATE LAW AND THE CITY CONFLICT OF INTEREST CODE REQUIRES THAT LIBRARY BOARD OF TRUSTEE MEMBERS AND PLANNING COMMISSIONERS FILE A STATEMENT OF ECONOMIC INTERESTS (FORM 700) ANNUALLY AS WELL AS RELATED FORMS WHEN ASSUMING AND LEAVING OFFICE (e.g. sources of income, loans, gifts, investments, interest in real property as required by state law). DO YOU AGREE TO FILE ALL REQUIRED FORMS IN A TIMELY MANNER AS REQUIRED BY THE CITY'S FILING OFFICIAL?

YES  NO

---

**\*ARCADIA BEAUTIFUL APPLICANTS ONLY**

ARE YOU AWARE THAT THE PRIMARY FUNCTION OF THE ARCADIA BEAUTIFUL COMMISSION IS TO ACT AS JUDGES FOR THE COMMISSIONS AWARD PROGRAMS (Spring Home, Holiday Decoration, and Water Smart Hero awards)?

YES  NO

DO YOU HAVE THE ABILITY TO TRAVEL BY CAR DURING THE DAY AND IN THE EVENING FOR THE PURPOSE OF JUDGING?

YES  NO

THE ARCADIA BEAUTIFUL COMMISSION USUALLY HAS FOUR REGULAR MEETINGS EACH YEAR WITH ADDITIONAL MEETINGS AND/OR TIME COMMITMENTS SCHEDULED FOR THE PURPOSE OF CONDUCTING JUDGING FOR THE AWARD PROGRAMS, PARTICIPATING IN A 3-4 HOUR HOLIDAY DECORATION AWARD RECOGNITION EVENT, AND PARTICIPATING IN ARBOR DAY PROGRAMS. ADDITIONALLY, PRELIMINARY JUDGING FOR THE SPRING HOME AND HOLIDAY DECORATION AWARDS IS DONE WITH EACH COMMISSIONER TAKING RESPONSIBILITY FOR A SECTION OF THE CITY AND DRIVING THROUGH THE NEIGHBORHOODS TO SELECT THEIR NOMINATIONS FOR FINAL JUDGING BY THE COMMISSION. ARE YOU ABLE TO FULFILL THIS TIME COMMITMENT?

YES  NO

---

I HEREBY CERTIFY THAT THE FOREGOING INFORMATION IS TRUE AND CORRECT TO THE BEST OF MY KNOWLEDGE.

  
\_\_\_\_\_  
SIGNATURE

4/15/2026  
\_\_\_\_\_  
DATE

NOTE: The City of Arcadia reserves the right to use the information provided on this application to verify your residential address and voter registration status. The information provided on this application is for internal use only and confidential information will not be released to the public.

PLEASE SUBMIT YOUR COMPLETED APPLICATION TO: CITY CLERK'S OFFICE  
240 W. HUNTINGTON DRIVE  
ARCADIA, CA 91007



OR

Email us at [CityClerk@ArcadiaCA.gov](mailto:CityClerk@ArcadiaCA.gov)

Questions? Please contact us at (626) 574-5455

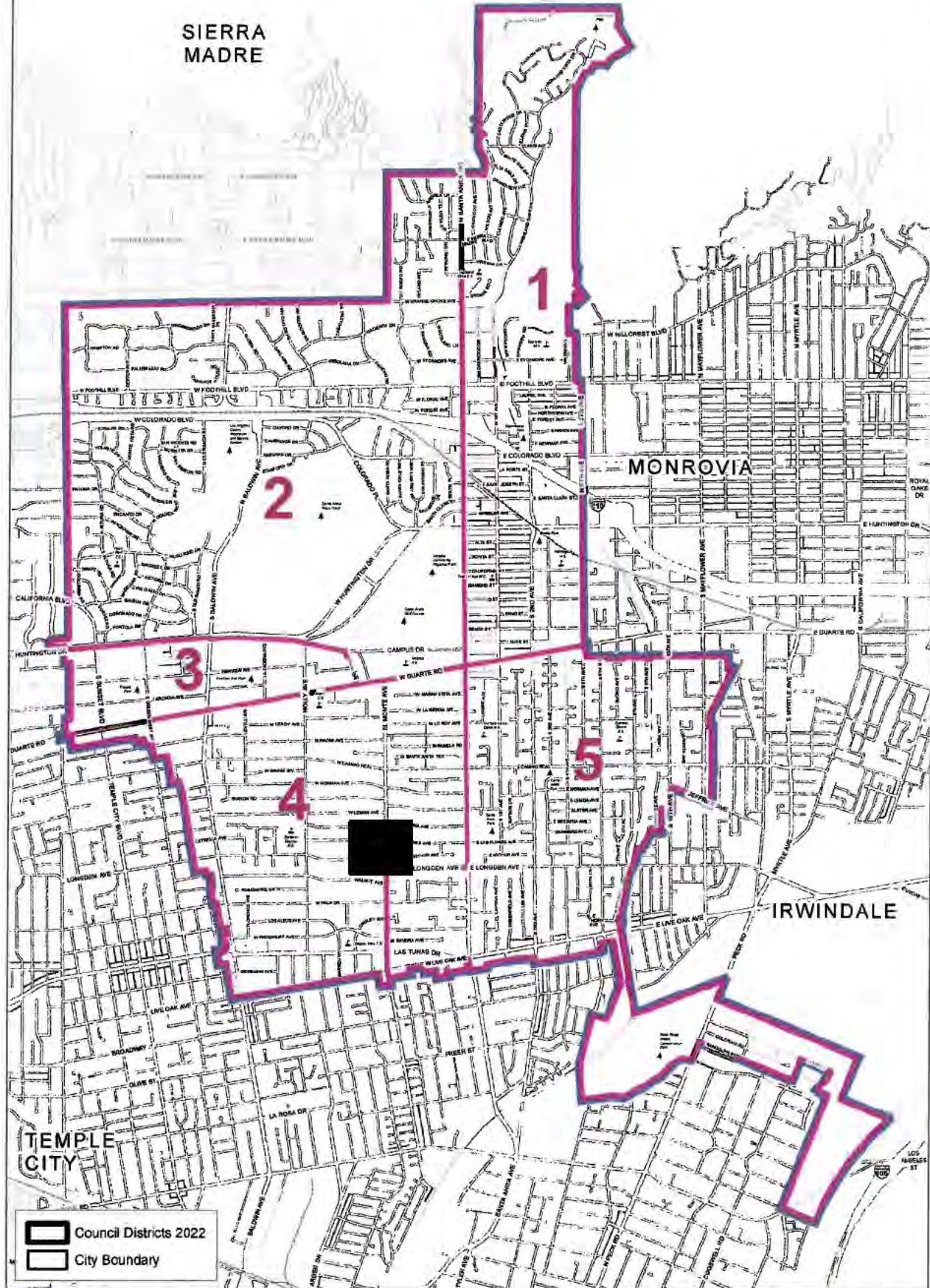
SIERRA MADRE



 Council Districts 2022  
 City Boundary



**Council District**  
 City of Arcadia, California



# City of Arcadia

## Board/Commission Application

RECEIVED

APR 23 2026

PLEASE PLACE A CHECK MARK NEXT TO THE BOARD OR COMMISSION FOR WHICH YOU WOULD LIKE TO APPLY (more than one selection may be made):

CITY OF ARCADIA

- Arcadia Beautiful Commission\*
- Arcadia Museum Commission
- Human Resources Commission
- Library Board of Trustees

- Planning Commission
- Recreation and Parks Commission
- Senior Citizens Commission
- Arcadia Health Commission

① opt  
② opt

NAME Qun (Connie) Liao DATE OF BIRTH (mm/dd/yyyy) [REDACTED]

RESIDENTIAL ADDRESS [REDACTED] Arcadia CA  
(Note: Cannot be a mailing address or PO Box)

BUSINESS ADDRESS (HEALTH COMMISSION ONLY) \_\_\_\_\_

I CERTIFY THAT I AM A RESIDENT OF DISTRICT  ONE  TWO  THREE  FOUR  FIVE  
 N/A (Health Commission Only)

PHONE NUMBER [REDACTED] EMAIL ADDRESS [REDACTED]

OCCUPATION retired EMPLOYER [REDACTED]

ARE YOU AN ARCADIA REGISTERED VOTER?  YES  NO

HOW LONG HAVE YOU BEEN A RESIDENT? (if Applicable) 28 years

PLEASE ANSWER THE QUESTIONS BELOW. YOU MAY USE ADDITIONAL SHEETS OF PAPER AS NECESSARY.

EDUCATION (Include professional or vocational licenses or certificates)

Dual - Master Degrees, Economics and MIS

COMMUNITY INVOLVEMENT (List organization memberships and committee assignments)

Arcadia Chinese Association  
Arcadia Public Library Board of Trustees

PLEASE DESCRIBE ANY BACKGROUND, TRAINING, OR INTERESTS THAT QUALIFY YOU AS AN APPOINTEE  
Senior Director, Data Management, Market Share  
Ex-President, Arcadia Chinese Association  
Committee Chair, Boy Scout Troop 138

WHAT INTERESTS YOU ABOUT THE BOARD/COMMISSION YOU ARE APPLYING FOR?

As the board director I worked with Arcadia Community center of ACA to co-host many community events, i.e. Moon Festival, Seniors luncheon, etc.

ARE YOU AWARE OF THE TIME COMMITMENT NECESSARY TO FULFILL THE OBLIGATIONS OF AN APPOINTMENT TO THIS POSITION?

YES  NO

NOTE: FOR LIBRARY BOARD OF TRUSTEE AND PLANNING COMMISSION APPLICATIONS ONLY  
STATE LAW AND THE CITY CONFLICT OF INTEREST CODE REQUIRES THAT LIBRARY BOARD OF TRUSTEE MEMBERS AND PLANNING COMMISSIONERS FILE A STATEMENT OF ECONOMIC INTERESTS (FORM 700) ANNUALLY AS WELL AS RELATED FORMS WHEN ASSUMING AND LEAVING OFFICE (e.g. sources of income, loans, gifts, investments, interest in real property as required by state law). DO YOU AGREE TO FILE ALL REQUIRED FORMS IN A TIMELY MANNER AS REQUIRED BY THE CITY'S FILING OFFICIAL?

YES  NO

---

**\*ARCADIA BEAUTIFUL APPLICANTS ONLY**

ARE YOU AWARE THAT THE PRIMARY FUNCTION OF THE ARCADIA BEAUTIFUL COMMISSION IS TO ACT AS JUDGES FOR THE COMMISSIONS AWARD PROGRAMS (Spring Home, Holiday Decoration, and Water Smart Hero awards)?

YES  NO

DO YOU HAVE THE ABILITY TO TRAVEL BY CAR DURING THE DAY AND IN THE EVENING FOR THE PURPOSE OF JUDGING?

YES  NO

THE ARCADIA BEAUTIFUL COMMISSION USUALLY HAS FOUR REGULAR MEETINGS EACH YEAR WITH ADDITIONAL MEETINGS AND/OR TIME COMMITMENTS SCHEDULED FOR THE PURPOSE OF CONDUCTING JUDGING FOR THE AWARD PROGRAMS, PARTICIPATING IN A 3-4 HOUR HOLIDAY DECORATION AWARD RECOGNITION EVENT, AND PARTICIPATING IN ARBOR DAY PROGRAMS. ADDITIONALLY, PRELIMINARY JUDGING FOR THE SPRING HOME AND HOLIDAY DECORATION AWARDS IS DONE WITH EACH COMMISSIONER TAKING RESPONSIBILITY FOR A SECTION OF THE CITY AND DRIVING THROUGH THE NEIGHBORHOODS TO SELECT THEIR NOMINATIONS FOR FINAL JUDGING BY THE COMMISSION. ARE YOU ABLE TO FULFILL THIS TIME COMMITMENT?

YES  NO

---

I HEREBY CERTIFY THAT THE FOREGOING INFORMATION IS TRUE AND CORRECT TO THE BEST OF MY KNOWLEDGE.

  
SIGNATURE

4/22/2026  
DATE

NOTE: The City of Arcadia reserves the right to use the information provided on this application to verify your residential address and voter registration status. The information provided on this application is for internal use only and confidential information will not be released to the public.

PLEASE SUBMIT YOUR COMPLETED APPLICATION TO: CITY CLERK'S OFFICE  
240 W. HUNTINGTON DRIVE  
ARCADIA, CA 91007

OR

Email us at [CityClerk@ArcadiaCA.gov](mailto:CityClerk@ArcadiaCA.gov)

Questions? Please contact us at (626) 574-5455

SIERRA MADRE

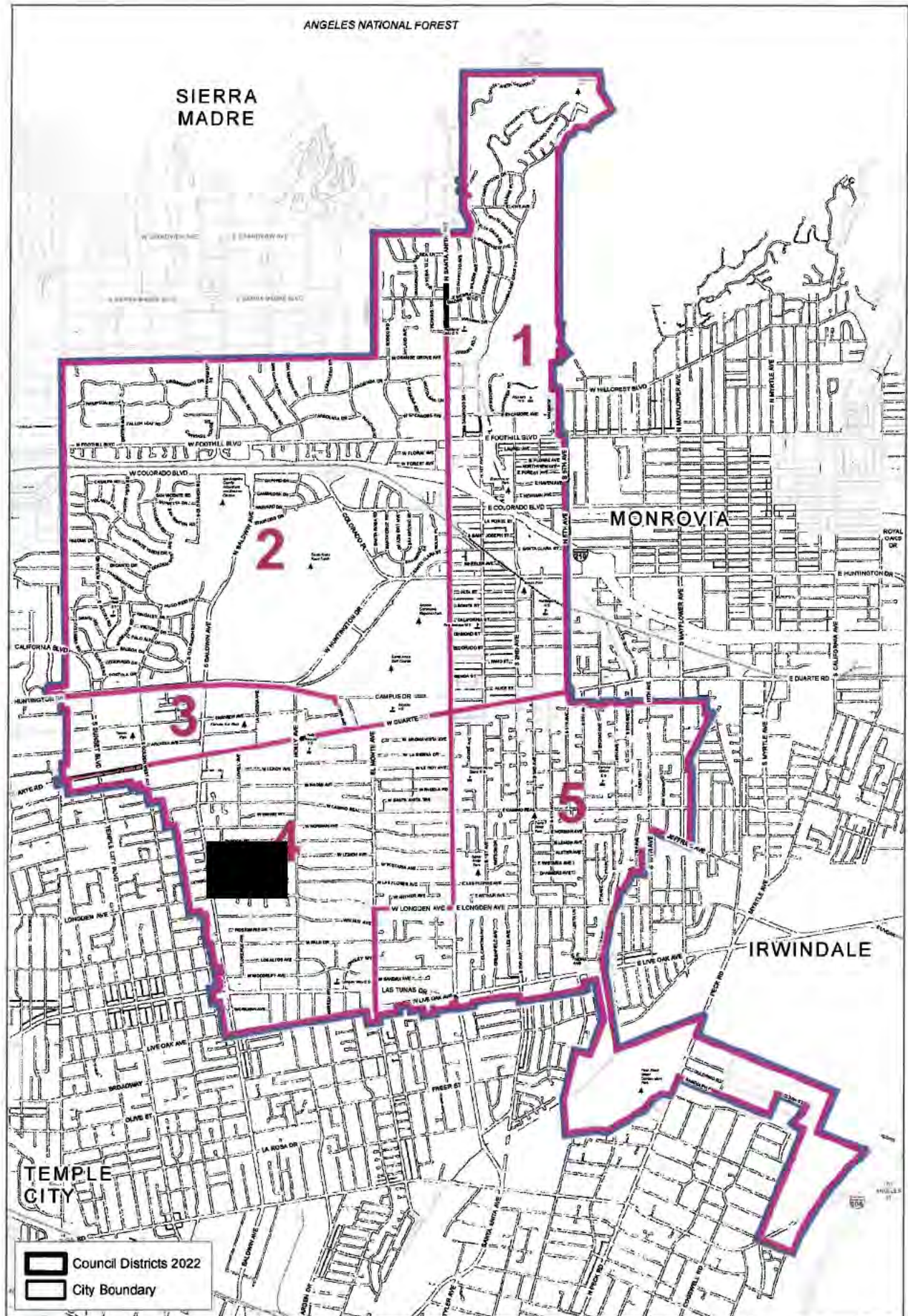

**Council District**  
 City of Arcadia, California



# City of Arcadia Board/Commission Application

RECEIVED

MAY 19 2026

PLEASE PLACE A CHECK MARK NEXT TO THE BOARD OR COMMISSION FOR WHICH YOU WOULD LIKE TO APPLY (more than one selection may be made):

CITY OF ARCADIA

- Arcadia Beautiful Commission\*
- Arcadia Museum Commission
- Human Resources Commission
- Library Board of Trustees
- Planning Commission
- Recreation and Parks Commission
- Senior Citizens Commission
- Arcadia Health Commission

NAME Miriam Carter DATE OF BIRTH (mm/dd/yyyy) 

RESIDENTIAL ADDRESS  Arcadia, CA  
(Note: Cannot be a mailing address or PO Box)

BUSINESS ADDRESS (HEALTH COMMISSION ONLY) \_\_\_\_\_

I CERTIFY THAT I AM A RESIDENT OF DISTRICT  ONE  TWO  THREE  FOUR  FIVE  
 N/A (Health Commission Only)

PHONE NUMBER  EMAIL ADDRESS   
OCCUPATION Teacher EMPLOYER University of Phoenix

ARE YOU AN ARCADIA REGISTERED VOTER?  YES  NO

HOW LONG HAVE YOU BEEN A RESIDENT? (If Applicable) 60 yrs

PLEASE ANSWER THE QUESTIONS BELOW. YOU MAY USE ADDITIONAL SHEETS OF PAPER AS NECESSARY.

**EDUCATION (Include professional or vocational licenses or certificates)**

MA - Curriculum and Instruction - UCLA, CSLA

**COMMUNITY INVOLVEMENT (List organization memberships and committee assignments)**

Assistance League LA county Arboretum Arcadia Library Board of Trustees Commissioner

**PLEASE DESCRIBE ANY BACKGROUND, TRAINING, OR INTERESTS THAT QUALIFY YOU AS AN APPOINTEE**

ECC Tutor Arcadia Library  
Arcadia Arboretum docent-history and botanical  
UOP Course facilitator and Faculty Supervisor  
CERT qualified

**WHAT INTERESTS YOU ABOUT THE BOARD/COMMISSION YOU ARE APPLYING FOR?**

I have previously served on the Senior Commission, once as Chairman.  
As long as I can, I want to be an advocate for seniors in our community.

ARE YOU AWARE OF THE TIME COMMITMENT NECESSARY TO FULFILL THE OBLIGATIONS OF AN APPOINTMENT TO THIS POSITION?

YES  NO

NOTE: FOR LIBRARY BOARD OF TRUSTEE AND PLANNING COMMISSION APPLICATIONS ONLY  
STATE LAW AND THE CITY CONFLICT OF INTEREST CODE REQUIRES THAT LIBRARY BOARD OF TRUSTEE MEMBERS AND PLANNING COMMISSIONERS FILE A STATEMENT OF ECONOMIC INTERESTS (FORM 700) ANNUALLY AS WELL AS RELATED FORMS WHEN ASSUMING AND LEAVING OFFICE (e.g. sources of income, loans, gifts, investments, interest in real property as required by state law). DO YOU AGREE TO FILE ALL REQUIRED FORMS IN A TIMELY MANNER AS REQUIRED BY THE CITY'S FILING OFFICIAL?

YES  NO

---

**\*ARCADIA BEAUTIFUL APPLICANTS ONLY**

ARE YOU AWARE THAT THE PRIMARY FUNCTION OF THE ARCADIA BEAUTIFUL COMMISSION IS TO ACT AS JUDGES FOR THE COMMISSIONS AWARD PROGRAMS (Spring Home, Holiday Decoration, and Water Smart Hero awards)?

YES  NO

DO YOU HAVE THE ABILITY TO TRAVEL BY CAR DURING THE DAY AND IN THE EVENING FOR THE PURPOSE OF JUDGING?

YES  NO

THE ARCADIA BEAUTIFUL COMMISSION USUALLY HAS FOUR REGULAR MEETINGS EACH YEAR WITH ADDITIONAL MEETINGS AND/OR TIME COMMITMENTS SCHEDULED FOR THE PURPOSE OF CONDUCTING JUDGING FOR THE AWARD PROGRAMS, PARTICIPATING IN A 3-4 HOUR HOLIDAY DECORATION AWARD RECOGNITION EVENT, AND PARTICIPATING IN ARBOR DAY PROGRAMS. ADDITIONALLY, PRELIMINARY JUDGING FOR THE SPRING HOME AND HOLIDAY DECORATION AWARDS IS DONE WITH EACH COMMISSIONER TAKING RESPONSIBILITY FOR A SECTION OF THE CITY AND DRIVING THROUGH THE NEIGHBORHOODS TO SELECT THEIR NOMINATIONS FOR FINAL JUDGING BY THE COMMISSION. ARE YOU ABLE TO FULFILL THIS TIME COMMITMENT?

YES  NO

---

I HEREBY CERTIFY THAT THE FOREGOING INFORMATION IS TRUE AND CORRECT TO THE BEST OF MY KNOWLEDGE.

\_\_\_\_\_  
May 19, 2026

DATE

NOTE: The City of Arcadia reserves the right to use the information provided on this application to verify your residential address and voter registration status. The information provided on this application is for internal use only and confidential information will not be released to the public.

PLEASE SUBMIT YOUR COMPLETED APPLICATION TO: CITY CLERK'S OFFICE  
240 W. HUNTINGTON DRIVE  
ARCADIA, CA 91007

OR

Email us at [CityClerk@ArcadiaCA.gov](mailto:CityClerk@ArcadiaCA.gov)

Questions? Please contact us at (626) 574-5455

SIERRA MADRE

MONROVIA

IRWINDALE

TEMPLE CITY

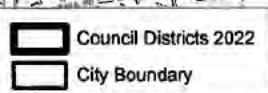
 Council Districts 2022  
 City Boundary

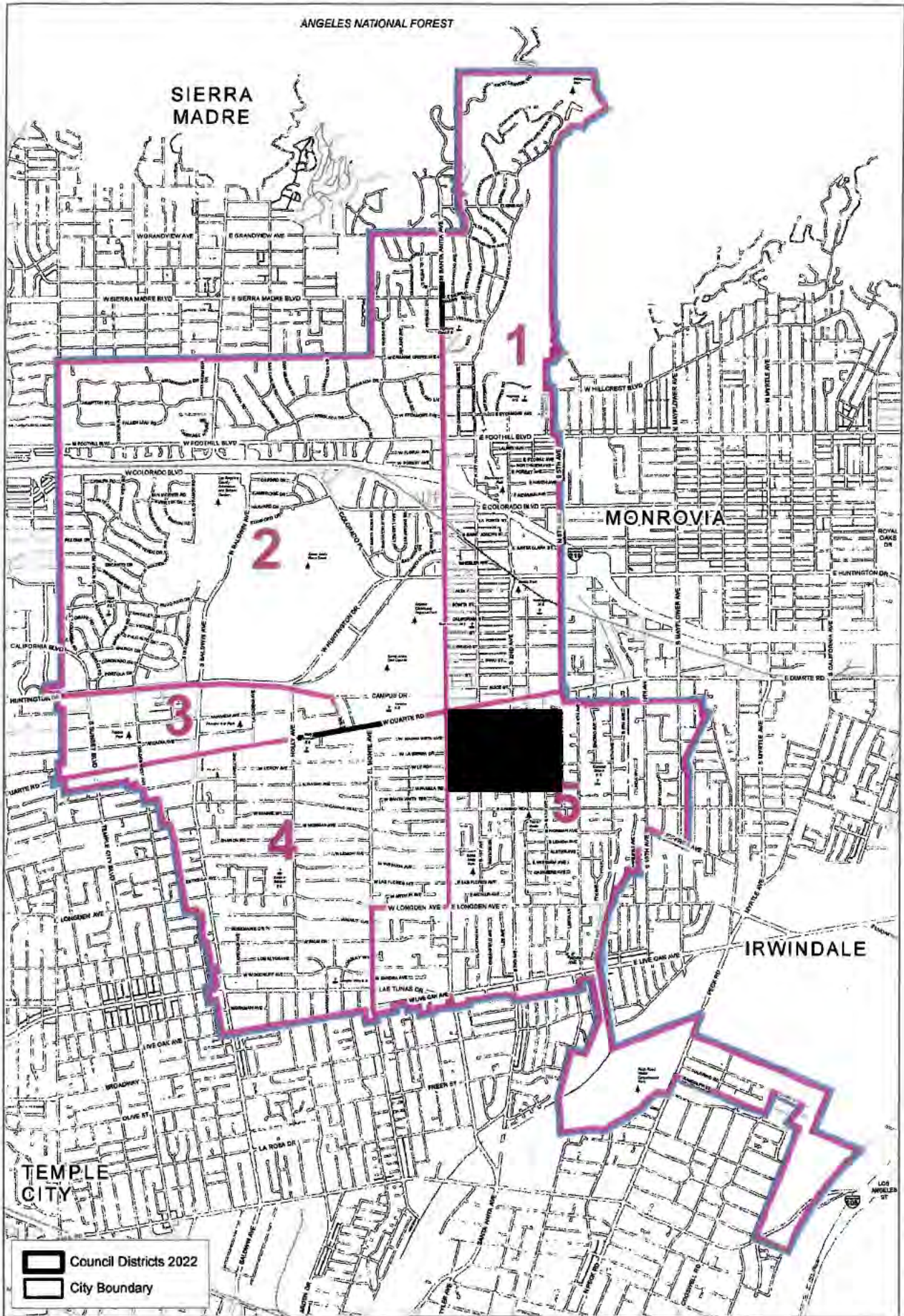

**Council District**  
*City of Arcadia, California*



# City of Arcadia Board/Commission Application

RECEIVED

MAY 26 2026

PLEASE PLACE A CHECK MARK NEXT TO THE BOARD OR COMMISSION FOR WHICH YOU WOULD LIKE TO APPLY (more than one selection may be made):

CITY OF ARCADIA  
CITY CLERK

- Arcadia Beautiful Commission\*
- Arcadia Museum Commission
- Human Resources Commission
- Library Board of Trustees
- Planning Commission
- Recreation and Parks Commission
- Senior Citizens Commission
- Arcadia Health Commission

NAME Derek Yeung DATE OF BIRTH (mm/dd/yyyy) [REDACTED]

FIRST LAST

RESIDENTIAL ADDRESS [REDACTED] Arcadia, CA 91006

(Note: Cannot be a mailing address or PO Box)

BUSINESS ADDRESS (HEALTH COMMISSION ONLY) \_\_\_\_\_

I CERTIFY THAT I AM A RESIDENT OF DISTRICT  ONE  TWO  THREE  FOUR  FIVE  
 N/A (Health Commission Only)

PHONE NUMBER [REDACTED] EMAIL ADDRESS [REDACTED]

OCCUPATION Patent and Intectural Property Attorney EMPLOYER Loza & Loza, LLP

ARE YOU AN ARCADIA REGISTERED VOTER?  YES  NO

HOW LONG HAVE YOU BEEN A RESIDENT? (If Applicable) In Arcadia since 1991

PLEASE ANSWER THE QUESTIONS BELOW. YOU MAY USE ADDITIONAL SHEETS OF PAPER AS NECESSARY.

### EDUCATION (Include professional or vocational licenses or certificates)

Southwestern Law Shool, JD, 2006  
USC Master of Science, Electrical Engineer 1993  
Cal State University Long Beach, Bachelor of Science, Electrical Engineer 1991

### COMMUNITY INVOLVEMENT (List organization memberships and committee assignments)

As a Patent Attorney, I involved in events as pro bono lawyer hosted by San Gabriel Bar Association. While my boys were in Boy Scouts, I was Merit Badge Coach teaching various classes and also was leader chaperoning and guiding the scouts for activities like overnight camping, events activities, etc.

### PLEASE DESCRIBE ANY BACKGROUND, TRAINING, OR INTERESTS THAT QUALIFY YOU AS AN APPOINTEE

I have empathy and sufficient city's knowledge and collaborative skills. Also, with my attorney background and has a pretty up to date technology side and abreast in up to date US and World News, I believe I can share different view points and comfortable to fit in other commissioners and seniors building consensus. Also, as a senior myself as over 50 years old qualifies in Senior activities organized by the city, I would like to serve in the local senior events.

### WHAT INTERESTS YOU ABOUT THE BOARD/COMMISSION YOU ARE APPLYING FOR?

In this everyday changing AI world, with my technical background and knowledge, I believe I can offer my background enhancing any current senior activities offered by the city and hope I can serve the city both objectively and subjectively as a good listener. I hope to improve the future transit needs and also create more diverse wellness programs that attract a new generation of retiring residents in all ethnicities as a happy big Arcadian family.

ARE YOU AWARE OF THE TIME COMMITMENT NECESSARY TO FULFILL THE OBLIGATIONS OF AN APPOINTMENT TO THIS POSITION?

YES  NO

NOTE: FOR LIBRARY BOARD OF TRUSTEE AND PLANNING COMMISSION APPLICATIONS ONLY  
STATE LAW AND THE CITY CONFLICT OF INTEREST CODE REQUIRES THAT LIBRARY BOARD OF TRUSTEE MEMBERS AND PLANNING COMMISSIONERS FILE A STATEMENT OF ECONOMIC INTERESTS (FORM 700) ANNUALLY AS WELL AS RELATED FORMS WHEN ASSUMING AND LEAVING OFFICE (e.g. sources of income, loans, gifts, investments, interest in real property as required by state law). DO YOU AGREE TO FILE ALL REQUIRED FORMS IN A TIMELY MANNER AS REQUIRED BY THE CITY'S FILING OFFICIAL?

YES  NO

---

**\*ARCADIA BEAUTIFUL APPLICANTS ONLY**

ARE YOU AWARE THAT THE PRIMARY FUNCTION OF THE ARCADIA BEAUTIFUL COMMISSION IS TO ACT AS JUDGES FOR THE COMMISSIONS AWARD PROGRAMS (Spring Home, Holiday Decoration, and Water Smart Hero awards)?

YES  NO

DO YOU HAVE THE ABILITY TO TRAVEL BY CAR DURING THE DAY AND IN THE EVENING FOR THE PURPOSE OF JUDGING?

YES  NO

THE ARCADIA BEAUTIFUL COMMISSION USUALLY HAS FOUR REGULAR MEETINGS EACH YEAR WITH ADDITIONAL MEETINGS AND/OR TIME COMMITMENTS SCHEDULED FOR THE PURPOSE OF CONDUCTING JUDGING FOR THE AWARD PROGRAMS, PARTICIPATING IN A 3-4 HOUR HOLIDAY DECORATION AWARD RECOGNITION EVENT, AND PARTICIPATING IN ARBOR DAY PROGRAMS. ADDITIONALLY, PRELIMINARY JUDGING FOR THE SPRING HOME AND HOLIDAY DECORATION AWARDS IS DONE WITH EACH COMMISSIONER TAKING RESPONSIBILITY FOR A SECTION OF THE CITY AND DRIVING THROUGH THE NEIGHBORHOODS TO SELECT THEIR NOMINATIONS FOR FINAL JUDGING BY THE COMMISSION. ARE YOU ABLE TO FULFILL THIS TIME COMMITMENT?

YES  NO

---

I HEREBY CERTIFY THAT THE FOREGOING INFORMATION IS TRUE AND CORRECT TO THE BEST OF MY KNOWLEDGE.

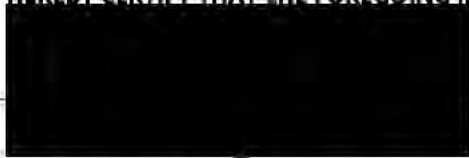

05/22/2026

DATE

NOTE: The City of Arcadia reserves the right to use the information provided on this application to verify your residential address and voter registration status. The information provided on this application is for internal use only and confidential information will not be released to the public.

PLEASE SUBMIT YOUR COMPLETED APPLICATION TO: CITY CLERK'S OFFICE  
240 W. HUNTINGTON DRIVE  
ARCADIA, CA 91007



OR

Email us at [CityClerk@ArcadiaCA.gov](mailto:CityClerk@ArcadiaCA.gov)

Questions? Please contact us at (626) 574-5455

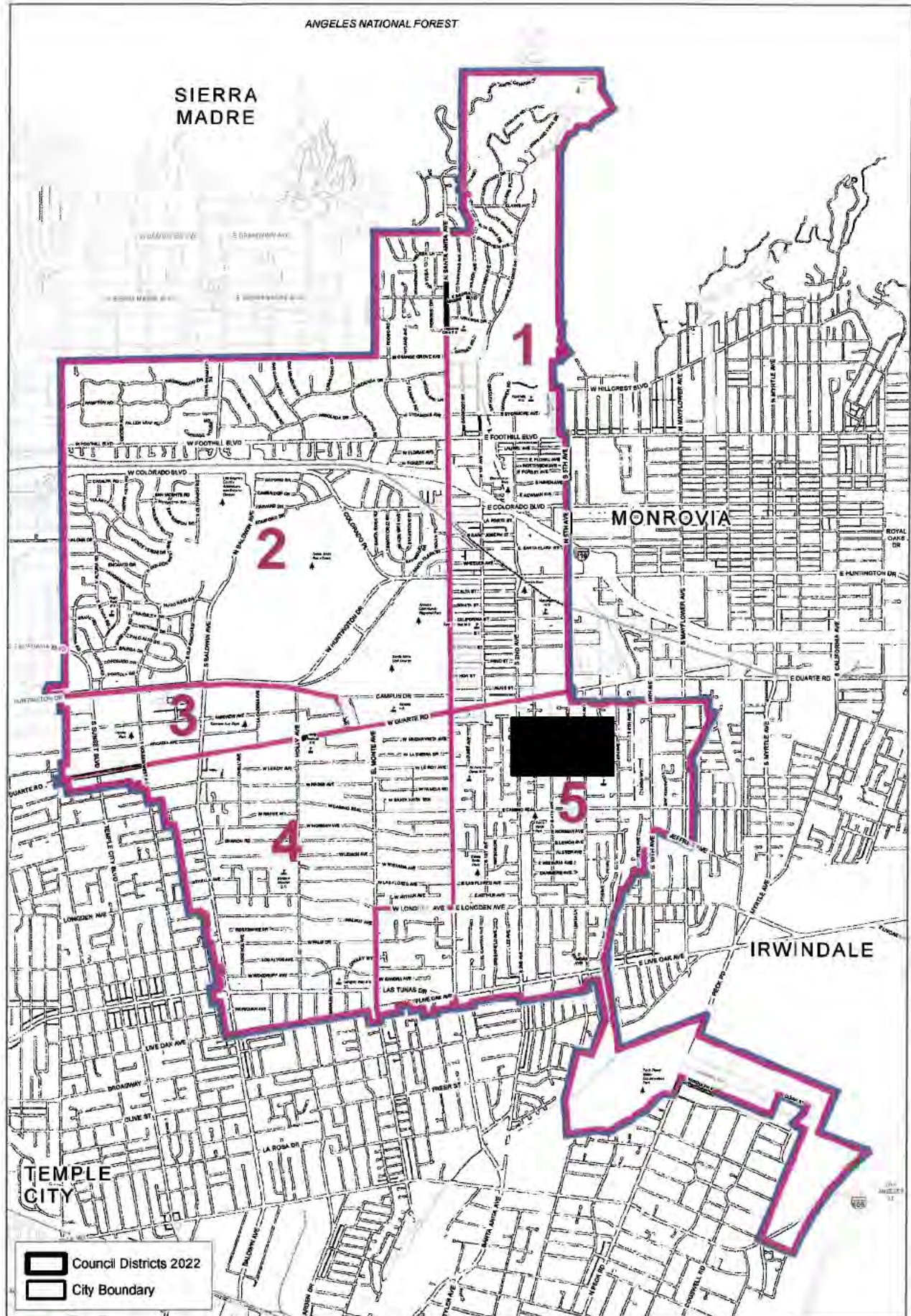
SIERRA MADRE



 Council Districts 2022  
 City Boundary



**Council District**  
*City of Arcadia, California*

# **CLUB APPOINTMENTS APPLICANTS**

RECEIVED  
CITY OF ARCADIA

JUN 04 2026

# Citizen Service Resume



**CITY MANAGER**  
PLEASE PLACE A CHECK MARK NEXT TO THE BOARD/COMMISSION FOR WHICH YOU WOULD LIKE TO APPLY (You may make more than one selection):

- Arcadia Beautiful Commission\*
- Arcadia Museum Commission
- Human Resources Commission
- Library Board of Trustees
- Planning Commission
- Recreation and Parks Commission
- Senior Citizens Commission

\*\*\*\*\*

NAME Donna Salter DATE OF BIRTH [REDACTED]

FIRST LAST

RESIDENTIAL ADDRESS [REDACTED] Arcadia, CA 91007

(Note: Cannot be a mailing address or PO Box)

I CERTIFY THAT I AM A RESIDENT OF DISTRICT  ONE  TWO  THREE  FOUR  FIVE

PHONE NUMBER [REDACTED] EMAIL ADDRESS [REDACTED]

OCCUPATION Executive Assistant

EMPLOYER Law Offices of Stephenson, Acquisto & Colman ARE YOU AN ARCADIA REGISTERED VOTER?  YES  NO

HOW LONG HAVE YOU BEEN A RESIDENT? 39 2/1 years ARE YOU A LEADERSHIP ACADEMY GRADUATE?  YES  NO

\*\*\*\*\*

PLEASE ANSWER THE QUESTIONS BELOW. YOU MAY USE ADDITIONAL SHEETS OF PAPER AS NECESSARY.

### EDUCATION (Include professional or vocational licenses or certificates)

Chandler School for Women  
Boston, MA  
Graduated in 1972 (Two-year Secretarial Course - AA Degree)

### COMMUNITY INVOLVEMENT (List organization memberships and committee assignments)

Longley Way PTA 1990 - 2002 (Served as Secretary for two years)  
Dana PTA 1996 - 2004 (Served as Secretary for two years)  
Arroyo Pacific Academy PTA 2004 - 2010 (Member of Parent Board)  
Las Alas (Auxiliary of Assistance League of Arcadia) Member since 2007 (Served on several board positions including Chairman 2015 - 2017)

### PLEASE DESCRIBE ANY BACKGROUND, TRAINING, OR INTERESTS THAT QUALIFY YOU AS AN APPOINTEE

My interest/training in seniors goes way back to my high school years when I worked as a nurse's aide at a nursing home on weekends and summers for three years. It was hard work, but I loved my job and my interactions with the residents/patients.

Twenty years later, my mother came to California from Boston to live with us. I witnessed her fulfilled life as she attended strength training and other classes at the Arcadia Senior Center. She was also a member of the Friendship Club and I loved hearing about her

### WHAT DO YOU SEE AS THE OBJECTIVES AND GOALS OF THE COMMISSION FOR WHICH YOU ARE APPLYING?

To be a good communication avenue for the Senior Citizens of Arcadia, the Arcadia City Council, and the Arcadia Recreation Department. Keeping everyone informed and aware when issues arise, is always a good thing.

ARE YOU AWARE OF THE TIME COMMITMENT NECESSARY TO FULFILL THE OBLIGATIONS OF AN APPOINTMENT TO THIS POSITION?

YES  NO

NOTE: FOR LIBRARY BOARD OF TRUSTEE & PLANNING COMMISSION APPLICATIONS ONLY  
STATE LAW AND THE CITY CONFLICT OF INTEREST CODE REQUIRES THAT LIBRARY BOARD OF TRUSTEE MEMBERS AND PLANNING COMMISSIONERS FILE A STATEMENT OF ECONOMIC INTERESTS (FORM 700) ANNUALLY AS WELL AS RELATED FORMS WHEN ASSUMING AND LEAVING OFFICE (e.g. sources of income, loans, gifts, investments, interest in real property as required by state law). DO YOU AGREE TO FILE ALL REQUIRED FORMS IN A TIMELY MANNER AS REQUIRED BY THE CITY'S FILING OFFICIAL?

YES  NO

\*\*\*\*\*

**\*ARCADIA BEAUTIFUL APPLICANTS ONLY**

ARE YOU AWARE THAT THE PRIMARY FUNCTION OF THE ARCADIA BEAUTIFUL COMMISSION IS TO ACT AS JUDGES FOR THE COMMISSIONS AWARD PROGRAMS (Spring Home, Holiday Decoration, and Water Smart Hero awards)?

YES  NO

DO YOU HAVE THE ABILITY TO TRAVEL BY CAR DURING THE DAY AND IN THE EVENING FOR THE PURPOSE OF JUDGING?

YES  NO

THE ARCADIA BEAUTIFUL COMMISSION USUALLY HAS FOUR REGULAR MEETINGS EACH YEAR WITH ADDITIONAL MEETINGS AND/OR TIME COMMITMENTS SCHEDULED FOR THE PURPOSE OF CONDUCTING JUDGING FOR THE AWARD PROGRAMS, PARTICIPATING IN A 3-4 HOUR HOLIDAY DECORATION AWARD RECOGNITION EVENT, AND PARTICIPATING IN ARBOR DAY PROGRAMS. ADDITIONALLY, PRELIMINARY JUDGING FOR THE SPRING HOME AND HOLIDAY DECORATION AWARDS IS DONE WITH EACH COMMISSIONER TAKING RESPONSIBILITY FOR A SECTION OF THE CITY AND DRIVING THROUGH THE NEIGHBORHOODS TO SELECT THEIR NOMINATIONS FOR FINAL JUDGING BY THE COMMISSION. ARE YOU ABLE TO FULFILL THIS TIME COMMITMENT?

YES  NO

\*\*\*\*\*

I HEREBY CERTIFY THAT THE FOREGOING INFORMATION IS TRUE AND CORRECT TO THE BEST OF MY KNOWLEDGE.

\_\_\_\_\_

06/03/2026

DATE

NOTE: The City of Arcadia reserves the right to use the information provided on this application to verify your residential address and voter registration status. The information provided on this application is for internal use only and confidential information will not be released to the public.

PLEASE SUBMIT YOUR COMPLETED APPLICATION TO: CITY CLERK'S OFFICE  
240 W. HUNTINGTON DRIVE  
ARCADIA, CA 91007

OR

Email us at [CityClerk@ArcadiaCA.gov](mailto:CityClerk@ArcadiaCA.gov)

Questions? Please contact us at (626) 574-5455



RECEIVED  
CITY OF ARCADIA

JUN 04 2026

CITY MANAGER

June 2, 2026

Arcadia City Council  
240 West Huntington Drive  
Arcadia, CA 91007

Dear Honorable Mayor and Council Members:

The Arcadia Assistance League recommends Donna Salter for appointment to the Senior Citizen's Commission for the term beginning July 1, 2026.

Sincerely,

A handwritten signature in cursive script that reads 'Ann Sotowa'.

Ann Sotowa  
President 2025-27  
Assistance League® of Arcadia  
100 S. Santa Anita Avenue  
Arcadia, CA 91006

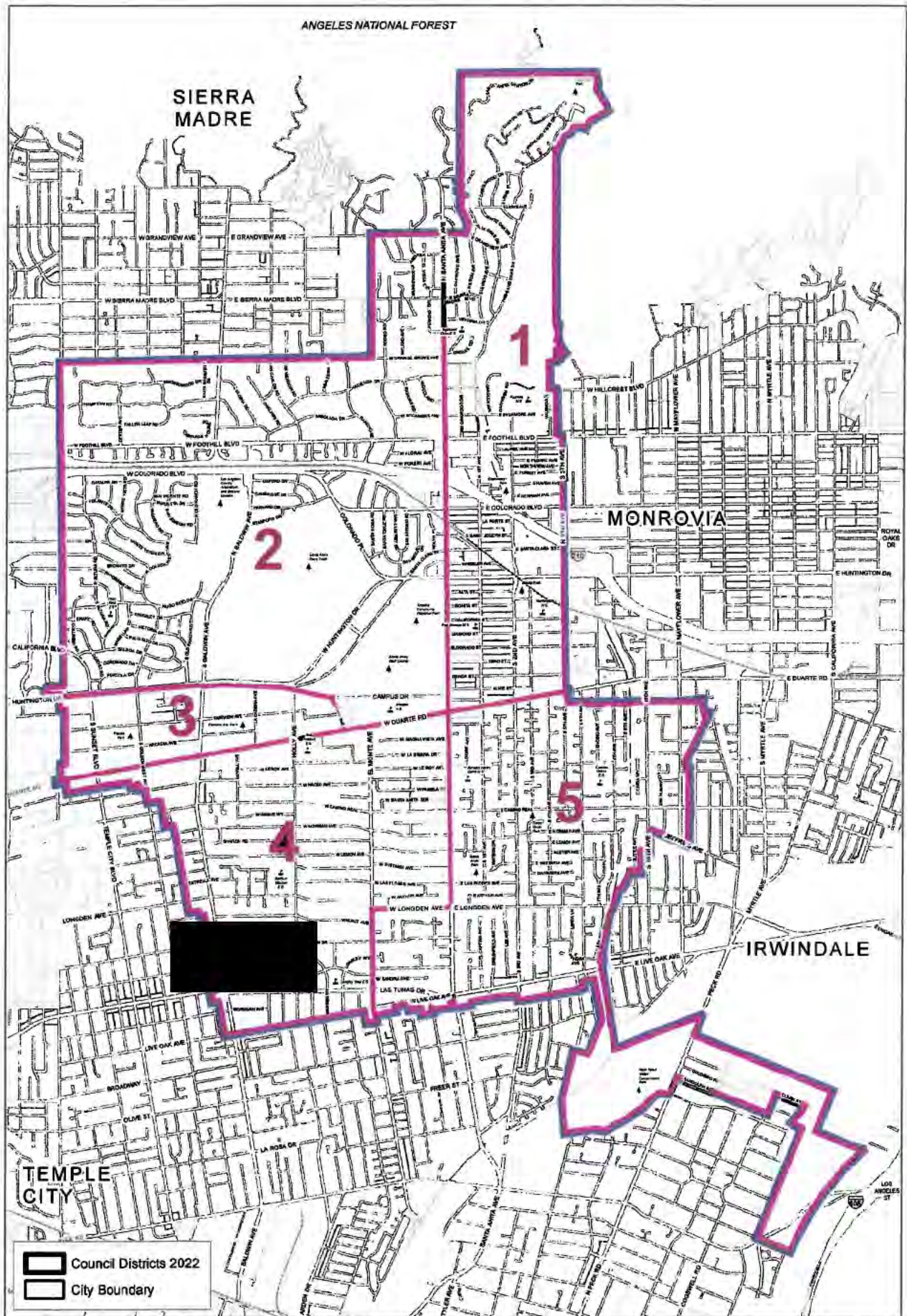

**Council District**  
City of Arcadia, California

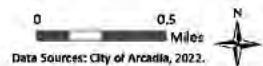



# Citizen Service Resume

CITY MANAGER

PLEASE PLACE A CHECK MARK NEXT TO THE BOARD/COMMISSION FOR WHICH YOU WOULD LIKE TO APPLY (You may make more than one selection):

- Arcadia Beautiful Commission\*
- Arcadia Museum Commission
- Human Resources Commission
- Library Board of Trustees
- Planning Commission
- Recreation and Parks Commission
- Senior Citizens Commission

\*\*\*\*\*  
 NAME DORIS ARBOUR DATE OF BIRTH [REDACTED]  
FIRST LAST

RESIDENTIAL ADDRESS [REDACTED] Arcadia, CA 91006  
(Note: Cannot be a mailing address or PO Box)

I CERTIFY THAT I AM A RESIDENT OF DISTRICT  ONE  TWO  THREE  FOUR  FIVE

PHONE NUMBER [REDACTED] EMAIL ADDRESS [REDACTED]

OCCUPATION Retired

EMPLOYER N/A ARE YOU AN ARCADIA REGISTERED VOTER?  YES  NO

HOW LONG HAVE YOU BEEN A RESIDENT? 59 ARE YOU A LEADERSHIP ACADEMY GRADUATE?  YES  NO

\*\*\*\*\*  
 PLEASE ANSWER THE QUESTIONS BELOW. YOU MAY USE ADDITIONAL SHEETS OF PAPER AS NECESSARY.

EDUCATION (Include professional or vocational licenses or certificates)  
Saint Albert High School Graduate Quebec Canada  
Golden Senior Club Treasurer

COMMUNITY INVOLVEMENT (List organization memberships and committee assignments)  
Currently A Senior Citizens Commissioner  
Golden Senior Club Treasurer

PLEASE DESCRIBE ANY BACKGROUND, TRAINING, OR INTERESTS THAT QUALIFY YOU AS AN APPOINTEE  
House Keeper for 30 years  
pharmaceutical company - Assisted with payroll

WHAT DO YOU SEE AS THE OBJECTIVES AND GOALS OF THE COMMISSION FOR WHICH YOU ARE APPLYING?  
To Bring Awareness to Seniors of All  
programs and Activities in the City of Arcadia

ARE YOU AWARE OF THE TIME COMMITMENT NECESSARY TO FULFILL THE OBLIGATIONS OF AN APPOINTMENT TO THIS POSITION?

YES  NO

NOTE: FOR LIBRARY BOARD OF TRUSTEE & PLANNING COMMISSION APPLICATIONS ONLY

STATE LAW AND THE CITY CONFLICT OF INTEREST CODE REQUIRES THAT LIBRARY BOARD OF TRUSTEE MEMBERS AND PLANNING COMMISSIONERS FILE A STATEMENT OF ECONOMIC INTERESTS (FORM 700) ANNUALLY AS WELL AS RELATED FORMS WHEN ASSUMING AND LEAVING OFFICE (e.g. sources of income, loans, gifts, investments, interest in real property as required by state law). DO YOU AGREE TO FILE ALL REQUIRED FORMS IN A TIMELY MANNER AS REQUIRED BY THE CITY'S FILING OFFICIAL?

YES  NO

\*\*\*\*\*

**\*ARCADIA BEAUTIFUL APPLICANTS ONLY**

ARE YOU AWARE THAT THE PRIMARY FUNCTION OF THE ARCADIA BEAUTIFUL COMMISSION IS TO ACT AS JUDGES FOR THE COMMISSIONS AWARD PROGRAMS (Spring Home, Holiday Decoration, and Water Smart Hero awards)?

YES  NO

DO YOU HAVE THE ABILITY TO TRAVEL BY CAR DURING THE DAY AND IN THE EVENING FOR THE PURPOSE OF JUDGING?

YES  NO

THE ARCADIA BEAUTIFUL COMMISSION USUALLY HAS FOUR REGULAR MEETINGS EACH YEAR WITH ADDITIONAL MEETINGS AND/OR TIME COMMITMENTS SCHEDULED FOR THE PURPOSE OF CONDUCTING JUDGING FOR THE AWARD PROGRAMS, PARTICIPATING IN A 3-4 HOUR HOLIDAY DECORATION AWARD RECOGNITION EVENT, AND PARTICIPATING IN ARBOR DAY PROGRAMS. ADDITIONALLY, PRELIMINARY JUDGING FOR THE SPRING HOME AND HOLIDAY DECORATION AWARDS IS DONE WITH EACH COMMISSIONER TAKING RESPONSIBILITY FOR A SECTION OF THE CITY AND DRIVING THROUGH THE NEIGHBORHOODS TO SELECT THEIR NOMINATIONS FOR FINAL JUDGING BY THE COMMISSION. ARE YOU ABLE TO FULFILL THIS TIME COMMITMENT?

YES  NO

\*\*\*\*\*

I HEREBY CERTIFY THAT THE FOREGOING INFORMATION IS TRUE AND CORRECT TO THE BEST OF MY KNOWLEDGE.



SIGNATURE

6/3/26

DATE

NOTE: The City of Arcadia reserves the right to use the information provided on this application to verify your residential address and voter registration status. The information provided on this application is for internal use only and confidential information will not be released to the public.

PLEASE SUBMIT YOUR COMPLETED APPLICATION TO: CITY CLERK'S OFFICE  
240 W. HUNTINGTON DRIVE  
ARCADIA, CA 91007

OR

Email us at [CityClerk@ArcadiaCA.gov](mailto:CityClerk@ArcadiaCA.gov)

Questions? Please contact us at (626) 574-5455

RECEIVED  
CITY OF ARCADIA

JUN 04 2026

CITY MANAGER

Golden Senior Club 4/20/26

Annie Beck,

This is to inform you that  
Doris Harbour will Renew  
New Term as Commissioner  
July 2026 - June 2028



Annie Slenaker  
President

SIERRA MADRE

MONROVIA

IRWINDALE

TEMPLE CITY

-  Council Districts 2022
-  City Boundary

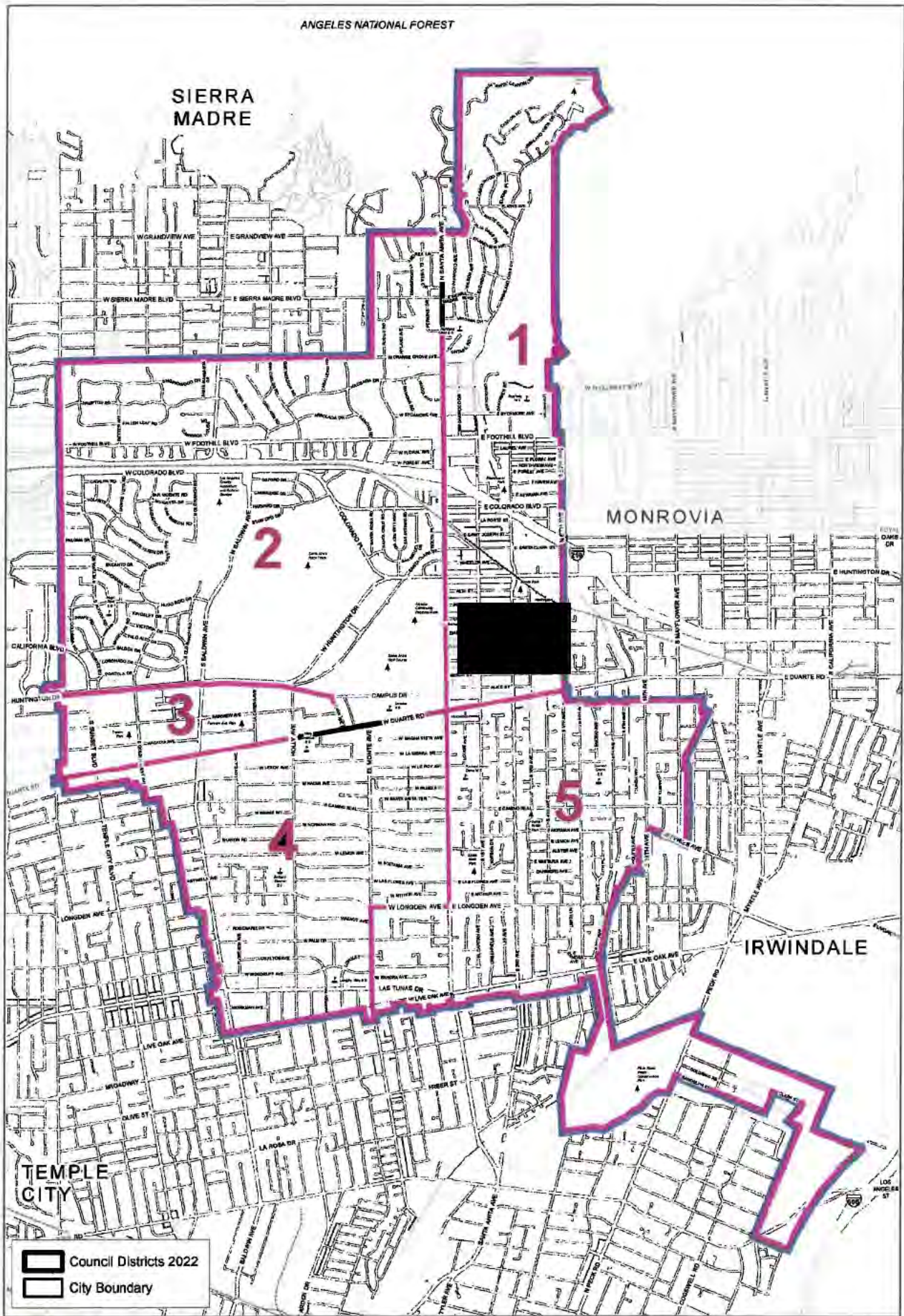

**DATE:** June 16, 2026

**TO:** Honorable Mayor and City Council

**FROM:** Dominic Lazzaretto, City Manager  
Henry Chen, Administrative Services Director

**SUBJECT:** RESOLUTIONS RELATING TO THE ADOPTION OF THE FISCAL YEAR 2026-27 OPERATING BUDGET AND THE FISCAL YEARS 2026-27 THROUGH 2030-31 CAPITAL IMPROVEMENT AND EQUIPMENT PLAN

RESOLUTION NO. 7696 ADOPTING A BUDGET FOR FISCAL YEAR 2026-27 AND APPROPRIATING THE AMOUNTS SPECIFIED THEREIN AS EXPENDITURES FROM THE VARIOUS FUNDS

**CEQA: Not a Project**

**Recommendation: Adopt**

RESOLUTION NO. 7697 ADOPTING A CAPITAL IMPROVEMENT AND EQUIPMENT PLAN FOR FISCAL YEARS 2026-27 THROUGH 2030-31

**CEQA: Not a Project**

**Recommendation: Adopt**

### **SUMMARY**

Sections 1204 and 1205 of the Arcadia City Charter require a public notice and a public hearing for consideration of the proposed Operating Budget and Five-Year Capital Program for the ensuing fiscal year, which is required to be adopted by July 1. The recommended actions are necessary to implement the budget for Fiscal Year 2026-27.

The public hearing for the budget was opened by the City Council at the June 2, 2026, meeting, and comments from members of the public were received and considered. Following the receipt of public comments, the public hearing was continued to the June 16 meeting, for further consideration and action.

Recent shifts in federal and state economic policy, persistent inflationary pressures, evolving trade and tariff conditions, and continued volatility in financial markets have created heightened uncertainty for both the national and regional economy, reinforcing the importance of prudent fiscal planning for the upcoming fiscal year. Due to Arcadia’s longstanding commitment to fiscal discipline and conservative budgeting practices, the City remains in a strong financial position and is well prepared to navigate potential economic challenges. While the City’s fiscal outlook remains stable, Arcadia will continue to maintain a cautious approach in implementing the FY 2026–27 Budget. This measured strategy positions the City to sustain high-quality public services, preserve financial flexibility, and proactively prepare for potential economic slowdowns or revenue fluctuations.

Given these dynamics, the FY 2026–27 Budget reflects a cautious but balanced fiscal strategy. City departments have carefully prepared the annual spending plan to maintain essential service levels while avoiding structural cost increases, where possible. The Budget can be considered a “status quo” type document with some proposed increases to address staffing needs and to enhance transparency and technological capabilities.

The proposed FY 2026-27 General Fund Operating Budget outlines Total Operating Revenues of \$96.6 million and Expenditures of \$100.1 million (including new programs). After accounting for all Transfers In and Out, the General Fund is expected to end the Fiscal Year with a positive net balance of \$276,000. At the end of FY 2026-27, the projected Fund Balance of the General Fund Operating Budget is expected to be \$21.7 million. The General Fund Operating Budget is summarized in the table below:

### GENERAL FUND SUMMARY

FY26-27 Budget	
Beginning Fund Balance	\$ 21,454,300
Estimated Revenues	96,563,100
Transfers In	9,516,000
Budgeted Expenses	(99,605,900)
Transfers Out	(912,000)
New Programs	(485,200)
Revenue over Expenses	\$ 5,076,000
Transfer to Equipment Replacement	(1,900,000)
Transfer to Capital Improvement Fund	(2,900,000)
Total Transfer Out	(4,800,000)
Subtotal Operating Balance	276,000
<b>Ending Fund Balance</b>	<b>\$ 21,730,300</b>

Overall, new programs proposed for the City's Operating Budget demonstrate Arcadia's commitment to being responsive to community needs.

In alignment with the City's long-term financial strategy, the proposed FY 2026-27 Budget allocates funds for addressing long-term liabilities. To this end, \$1.5 million has been allocated for the City's Pension and Other Post Employment Benefits ("OPEB") Trust accounts, which help address future employee benefits costs, especially in times of economic constraint. The \$1.5 million allocation is in addition to required payments to CalPERS, retiree healthcare premiums, and pension obligation bond payments.

This year's budget process started with a Budget Study Session with the City Council on May 5, 2026. After the initial study session, minor modifications were made to the proposed capital and equipment budgets. An additional \$25,000 for traffic signal improvements was added from the Proposition A Fund, bringing the total expenditure in the Capital Improvement Plan to \$17,285,100. For the Equipment Replacement Fund budget, some adjustments to the cost estimates for vehicles and communications equipment decreased the budgeted amount by \$148,000, to \$6,942,300.

The Capital Improvement Fund plays a vital role in funding crucial maintenance projects, including pavement rehabilitation, building repairs, and parks maintenance. In the FY 2026-27 Budget, \$4.8 million will be transferred into the Capital Improvement and Equipment Replacement Funds, with the Equipment Fund receiving \$1.9 million, and the Capital Improvement Fund receiving \$2.9 million. The transfer amounts equate to approximately the 10-year average spend in each account, collectively, with actual deposits being sent to the Fund with the greatest needs the in the near term.

Several key projects are budgeted within the Capital Improvement Fund, including facility improvements at the Arcadia Public Library, Council Chambers, and Community Center, as well as Citywide LED lighting upgrades. In response to increasingly stringent water quality standards, significant investment is also planned to expand the treatment capacity of the Orange Grove Well. The total proposed allocation for projects within the Capital Improvement Fund is \$7.3 million. When combined with capital projects funded through all sources, total capital investment for the Fiscal Year is budgeted at \$17.3 million.

The Equipment Replacement Fund is utilized to replace assets that have reached the end of their useful service life, including computers, vehicles, and major office equipment, thereby ensuring continuity in City operations. For FY 2026–27, a total of \$4.4 million is budgeted for equipment replacement activities. Notable expenditures include \$1.5 million for the replacement of the Police Department’s computer-aided dispatch and records management system, \$926,800 for vehicle replacements within the Streets Division, and \$286,300 for vehicle replacements within the Police Department.

It is recommended that the City Council determine that these actions do not constitute a project under the California Environmental Quality Act (“CEQA”); and:

- 1) Adopt Resolution No. 7696, adopting a Budget for Fiscal Year 2026-27 and appropriating the amounts specified therein as expenditures from the various funds; and
- 2) Adopt Resolution No. 7697, adopting a Capital Improvement and Equipment Plan for Fiscal Years 2026-27 through 2030-31.

## **BACKGROUND**

Sections 1204 and 1205 of the Arcadia City Charter require a public notice and a public hearing for consideration of the proposed Operating Budget and Five-Year Capital Program for the ensuing fiscal year. The annual Budget and associated documents are required to be adopted by July 1 each year. The recommended actions in this report are necessary to implement the Budget for Fiscal Year 2026-27.

This year's budget process started with a Budget Study Session with the City Council on May 5, 2026. Inclusive in the draft budget were all operating funds, including General, Special Revenue, Enterprise, and the Successor Agency. Additionally, the City Council received the Capital Improvement and Equipment Replacement Fund budgets in a separate document. All funds total \$206.4 million in expenditures, of which, the General Fund's budget is \$105.8 million (including Transfers Out as noted below).

After the initial study session, some modifications were made to the proposed Capital Improvement and Equipment Replacement Fund budgets. An additional \$25,000 for traffic signal improvements was added from the Proposition A Fund, bringing the total expenditures in the Capital Improvement Plan to \$17,285,100. For the Equipment Replacement Fund budget, some adjustments to the cost estimates for vehicles and the communications equipment decreased the budgeted amount by \$148,000 to \$6,942,300.

## **DISCUSSION**

As the Fiscal Year 2025–26 Operating Budget was being developed, the economic environment reflected elevated levels of uncertainty at global, national, and regional levels. The Fiscal Year 2026-27 Budget is being developed in a similar environment.

Current economic forecasts point to moderating but persistent inflation, slower economic growth, evolving federal and state policy decisions, and continued volatility in financial and energy markets. In California and the greater Los Angeles region, economic conditions remain mixed, with strength in technology and investment sectors offset by slower labor market growth, affordability challenges, and ongoing pressure on consumer costs. Continued trade and tariff uncertainties, military

actions worldwide, higher borrowing costs, and future inflationary pressures further contribute to an unpredictable fiscal outlook.

Given this complex and evolving environment, a wide range of economic outcomes remains possible, requiring cities to remain adaptable and fiscally prudent. Arcadia is maintaining a conservative and flexible budgeting approach to ensure the City can respond effectively to changing economic conditions, while continuing to provide high-quality public services and preserve long-term financial stability.

As in previous fiscal cycles, this discussion centers primarily on the General Fund, as Special Revenue, Enterprise, and Debt Service funds are restricted for specific purposes. Staff will continue to closely monitor economic trends throughout FY 2026–27 and return to the City Council with any recommended mid-year adjustments that may be necessary to maintain fiscal balance and service continuity, should conditions change significantly over the year.

Summarized in the table below is the General Fund Operating Budget, inclusive of the FY 2025-26 Year-End Estimates; FY 2026-27 Proposed Budget; FY 2027-28 Preliminary Budget; and the Ending Fund Balance, which is projected to reach \$21.5 million by the end of FY 2025-26, without any additional transfers into long-term savings accounts.

### THREE-YEAR GENERAL FUND BUDGET SUMMARY

	FY 25-26 Estimates	FY 26-27 Budget	FY 27-28 Budget
Beginning Fund Balance	\$ 29,319,400	\$ 21,454,300	\$ 21,730,300
Estimated Revenues	\$ 94,031,900	\$ 96,563,100	\$ 98,074,500
Transfers In	6,088,300	9,516,000	7,016,600
Expenses & Uses	(92,273,300)	(99,605,900)	(102,130,800)
Transfers Out	(912,000)	(912,000)	(912,000)
New Programs	0	(485,200)	(345,500)
Revenue over Expenses	\$ 6,934,900	\$ 5,076,000	\$ 1,702,800
Transfer to Equipment Replacement Fund	(1,900,000)	(1,900,000)	(1,900,000)
Transfer to Capital Improvement Fund	(2,900,000)	(2,900,000)	(2,900,000)
Total Transfer Out	(4,800,000)	(4,800,000)	(4,800,000)
Subtotal Operating Balance	2,134,900	276,000	(3,097,200)
Special One-Time Transfer	(10,000,000)	-	-
<b>Ending Fund Balance</b>	<b>\$ 21,454,300</b>	<b>\$ 21,730,300</b>	<b>\$ 18,633,100</b>

As shown in the table above, City staff had originally anticipated only a modest surplus for FY 2025–26; however, due to favorable revenue performance and effective expenditure management, the current Fiscal Year is now projected to close with an operating surplus of over \$2 million. The FY 2026–27 budget is currently projected to generate a surplus of approximately \$276,000, while the FY 2027–28 forecast reflects a projected deficit of approximately \$3 million based on standard growth assumptions and currently known economic indicators. This projected deficit is similar to the situation encountered in the previous Fiscal Year, where the out-year also forecast a potential shortfall.

The City's Executive Management Team will continue to closely monitor revenue trends, expenditure levels, and broader economic conditions throughout the Fiscal Year. As part of the City's ongoing commitment to fiscal responsibility, any necessary adjustments to revenues, expenditures, or operational assumptions will be evaluated to ensure that a balanced and sustainable budget is presented for adoption in the following Fiscal Year.

## **FY 2026-27 Expected Revenues**

When staff began formulating the FY 2026–27 Budget, economic trends and available data were presenting mixed and, at times, conflicting signals regarding the overall direction of the economy. In the absence of a clear and consistent trend, a conservative and cautious forecasting approach was adopted across the City’s major revenue sources.

For FY 2026-27, total General Fund revenues are expected to increase 2.62% when compared to FY 2025-26 Year-End Estimates. The largest revenue source for the City’s General Fund are taxes and fees. The key revenues under these two groups are: Sales & Use Tax, Property Tax, Utility Users’ Tax, Transient Occupancy Tax, and Motor Vehicle License Fees. The projected receipts for each tax are shown in the tables below:

### **GENERAL FUND REVENUES**

	FY 25-26	FY 26-27	Changes	
	Estimates	Budget	\$	%
Taxes	\$ 64,113,300	\$ 64,862,900	\$ 749,600	1.16%
License & Permits	6,788,300	7,919,300	1,131,000	14.28%
Fines & Penalties	430,700	551,500	120,800	21.90%
Use Money & Property	3,190,000	3,134,000	(56,000)	-1.79%
Revenue from Other Agen	10,124,100	10,315,100	191,000	1.85%
Charge Current Services	5,478,700	5,512,000	33,300	0.60%
Library	98,000	102,000	4,000	3.92%
Recreation	1,355,600	1,642,000	286,400	17.44%
Other Revenue	2,453,200	2,524,300	71,100	2.82%
<b>Total Revenue</b>	<b>\$ 94,031,900</b>	<b>\$ 96,563,100</b>	<b>\$ 2,531,200</b>	<b>2.62%</b>

## GENERAL FUND TAX REVENUE SUMMARY

Description	FY 2025-26 Estimate	FY 2026-27 Budget	Difference	% Change
Sales and Use Tax	\$ 24,962,900	\$ 25,305,100	\$ 342,200	1.35%
Property Tax	21,468,900	22,023,900	555,000	2.52%
Utility Users' Tax	9,807,400	9,999,400	192,000	1.92%
Transient Occupancy Tax	5,508,100	5,126,600	(381,500)	-7.44%
Motor Vehicle License Fees	9,818,500	10,029,100	210,600	2.10%

Sales and Transaction Use Tax: For Sales and Transaction Use Tax, total estimated revenues for the upcoming Fiscal Year are projected at \$25.3 million, representing a 1.35% increase over the current year's estimates. Recent retail data indicates moderate growth driven by regional consumer spending and continued inflationary impacts on taxable goods and services. Although overall economic growth is expected to remain modest, taxable sales activity in sectors such as retail, food services, technology, and construction materials continues to support local revenue generation. At the same time, increased volatility related to interest rates, tariffs, and the potential risk of an economic slowdown may affect the stability of future growth trends. All things considered, current trends continue to support a moderate level of sales tax revenue growth for the next Fiscal Year.

A key part of the Sales Tax projection is Measure A, a 0.75% Transaction and Use Tax approved by Arcadia voters in June 2019. Since its adoption, Measure A has strengthened the City's long-term fiscal stability and supported the continued delivery of essential municipal services. In Fiscal Year 2025–26 alone, Measure A is estimated to generate approximately \$11.7 million in revenue. The ongoing performance of Measure A has played a critical role in supporting the City's operational and financial needs, particularly during periods of economic uncertainty and rising service costs.

Property Tax: Property tax revenues for Fiscal Year 2026–27 are expected to be supported by continued increases in assessed property valuations and new development activity, resulting in moderate growth. However, growth trends are expected to be constrained relative to historical averages due to higher interest rates, slowing real estate market conditions, and broader economic uncertainty. The

City's reputation for providing a high quality of life, well-maintained neighborhoods, and highly regarded public schools is recognized as a key factor in sustaining long-term residential desirability. These conditions support steady housing demand, even during periods of elevated interest rates and broader economic uncertainty. These factors will contribute to a moderate growth in property taxes next Fiscal Year. For Fiscal Year 2026–27, property tax receipts are estimated to increase by approximately 2.52%, to \$22 million.

Utility Users' Tax ("UUT"): The projected revenue from the Utility Users' Tax is \$9.9 million, representing a 1.9% increase compared to the previous Fiscal Year. For Fiscal Year 2026–27, UUT revenues are generally expected to experience minimal growth, with performance primarily influenced by utility rate adjustments and shifts in household utility usage, rather than broader economic expansion. The rate changes are primarily driven by the need for utilities to invest in infrastructure resiliency compounded with expected increases in energy and water prices. These increases are expected to be partially offset by structural changes in telecommunications consumption, as usage continues to shift toward services that may be exempt from UUT under existing tax provisions.

Transient Occupancy Tax ("TOT"): The TOT revenue is projected to be \$5.1 million in FY 2026-27, representing a 7.4% decrease compared to the current Fiscal Year. Continued downward pressure on TOT revenues is expected to be driven by an uncertain travel and tourism environment, including ongoing geopolitical uncertainty. A current indicator of this uncertainty is the unexpectedly soft demand for 2026 World Cup tickets, and related hotel bookings. In addition, a portion of the decline is expected to result from the planned closure of up to two local hotel properties in the near term. As a result, overall hotel occupancy levels and related taxable room revenues are expected to soften, contributing to the projected decrease of \$381,500 in TOT collections for the upcoming Fiscal Year.

Motor Vehicle License Fees ("VLF"): The Motor Vehicle License Fees ("VLF") tax is projected to increase by 2.1%, generating \$10.0 million in revenue next Fiscal Year. Since the State implemented a formula-based adjustment that links the City's VLF allocation to annual assessed property valuations, VLF revenue growth in Arcadia has been consistently healthy.

Most other revenue areas are projected to be fairly flat or growing slightly during the upcoming Fiscal Year. A minor exception to this is the 1.79% expected decrease in the Use of Money and Property category, where declining federal interest rates will reduce the potential growth in the City's investments.

License and permit revenue is projected to increase 14.28% in Fiscal Year 2026–27, due primarily to higher building permit activity. The increase reflects continued development activity within the City, including both mixed-use and new hotel construction. Development, and permit-related revenues, are inherently variable and can fluctuate significantly from year-to-year based on the timing, size, and volume of construction activity within the City.

Revenue from fines and penalties is expected to increase \$120,800 in Fiscal Year 2026–27, primarily due to an increase in the number of citations issued, and an improved collection rate for delinquent citations. The increase reflects ongoing enhanced collection procedures that have contributed to higher overall revenue recovery.

Recreation revenues are forecasted to increase by 17.44% in Fiscal Year 2026–27, driven primarily by expanded programming. A significant factor contributing to the increase is the addition of the America's 250 Anniversary Event, which is expected to generate sponsorship and ticket revenues. Additional growth is also assumed from the expansion of recreation leagues and classes, reflecting continued demand for community-based programs and services.

## FY 2026-27 Proposed Expenses

### GENERAL FUND EXPENDITURES BY DEPARTMENT

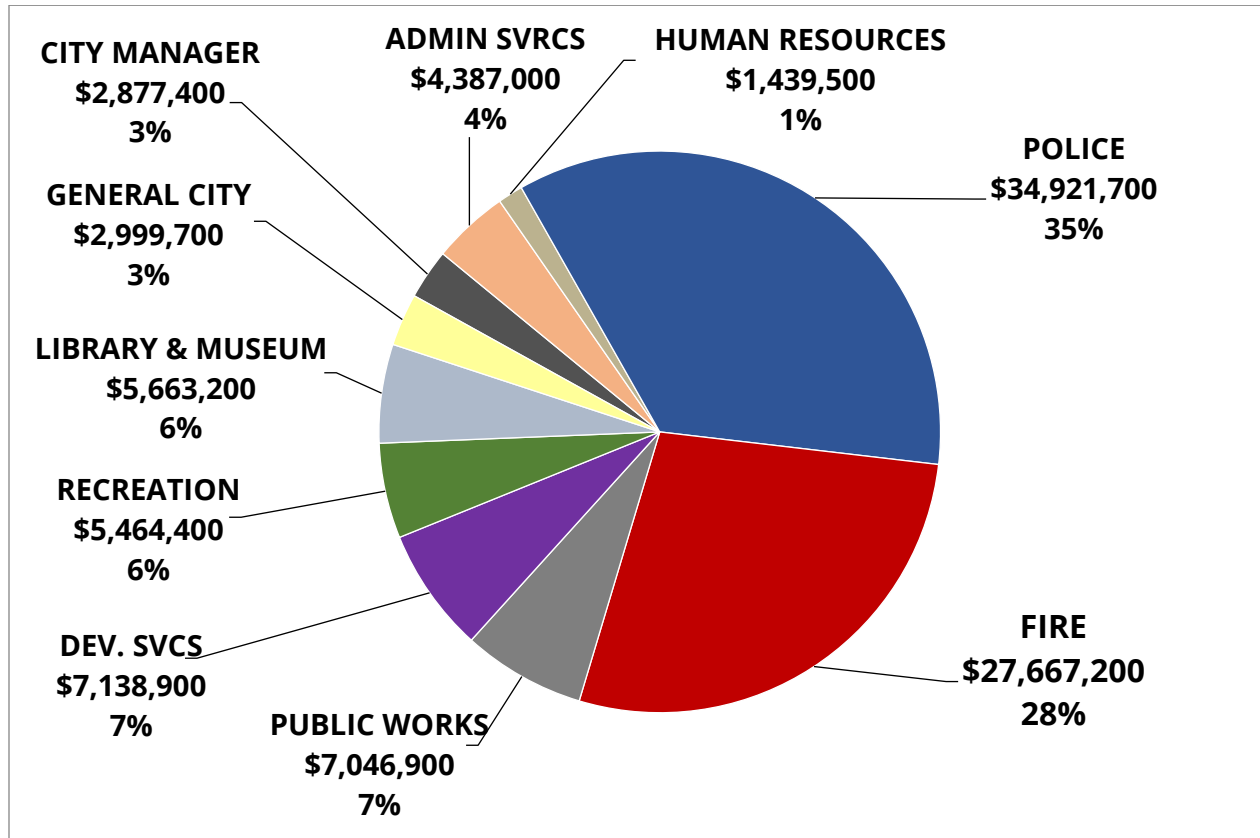

The proposed FY 2026-27 Operating Budget sets total operating expenditure at \$99.6 million, representing an 8.8% increase compared to the previous year's Revised Budget of \$91.5 million. Much of this increase can be attributed to contractual increases from multi-year service agreements, higher costs for supplies and materials due to increased pricing pressures, and the expected increases in salary and benefits for employees. The increases can generally be attributed to a high inflationary environment nationwide and particularly in the Southern California area.

Furthermore, the budget continues to allocate "prefunding" of long-term benefit accounts, including the City's Retiree Medical Benefit (Other Post Employee Benefit liabilities) and the contribution to the City's Pension Trust Account. The proposed budget includes a total of \$1.5 million for those accounts (\$750,000 each).

## **New Programs Proposed**

New services and programs are presented by various departments to respond to emerging operational needs and direction from the City Council. Most of the new programs support a combination of technology modernizations and providing greater transparency throughout the organization. New programs proposed for the FY 2026-27 Budget total \$485,200 and are described in the following sections.

**City Clerk's Office: Public Records Software (\$20,000):** The volume of California Public Records Act (CPRA) requests received and processed by the City has nearly doubled over the past three years alone. Currently, the process is fully manual and handled by a single employee, leading to inefficiencies and delays. The proposed software would support records request processing across all departments, except Police and Fire, which have dedicated staffing and handle records with greater levels of protected information. To manage the growing demand, the City Clerk's Office is pursuing an AI-driven solution to more effectively identify, locate, retrieve, and respond to public records requests.

**City Clerk's Office: Document Management System (\$40,000):** Arcadia currently uses a document management system to store and access public records and City documents, which include meeting agendas and minutes for City Council and City Boards and Commissions, contracts, permits, licenses, agreements, bids, and much more. Digital records date back to the 1950's and are available to the public through a portal on the City's website.

Currently, the system contains over 245,000 documents, for a total of 1.9 million pages and 735 gigabytes of storage space. The current contract for document management services will expire in June 2026, and a Request For Proposals ("RFP") process is underway to source a replacement system. The City uses a legacy version of Laserfiche that stores documents on a local server managed by City staff. It is expected that a new system would utilize cloud-based storage and be managed by the vendor. This approach will provide more reliable uptime, regular upgrades, and the ability for more users to simultaneously access documents and records. To reflect a new contract period at a higher level of service and sophistication, a \$40,000 budget is being requested to cover potential new costs. The requested amount will be refined based on RFP results. The City's current contract covers Police separately from the rest of the City, and both total approximately \$25,000 annually.

**Administrative Services Department: IT Coordinator (\$30,300):** Increased reliance on technology across City operations necessitates the establishment of a centralized coordination function to support the planning, development, and implementation of the City's information technology roadmap. This position would serve as a key liaison across departments to collect, assess, and prioritize technology needs, ensuring that operational requirements are clearly defined and aligned with the City's broader strategic objectives. The coordinator would be responsible for researching, evaluating, and recommending technology solutions, as well as assisting in the management of project resources to support the successful deployment of systems and services. This role would also support the coordination of implementation efforts across departments, helping to ensure that projects are delivered on time, within scope, and in alignment with established standards and goals. The request would be for a part-time employee or contractual hours with the City's current service provider, which are separate from routine help desk and maintenance type activities.

**Administrative Services Department: User and Impact Fee Update (\$100,000):** The City's last comprehensive User Fee Study was conducted in 2019. Since then, fees have been updated annually based on standard inflationary factors. The City's user fees are intended to cover the reasonable cost of providing specific services to individuals or entities, rather than relying on the general taxpayer. When fees are outdated, the gap between actual costs and collected revenues grows, effectively subsidizing fee-supported services with General Fund resources. Updating these fees ensures a fair allocation of costs, promotes fiscal sustainability, and preserves limited public funds for broader community priorities.

The City's current Park and Traffic Impact Fees have not been updated since 2007 and 2016, respectively. During this time, the cost of maintaining infrastructure and accommodating growth has increased significantly. As a result, existing fees may no longer reflect the true cost of service delivery or the impacts generated by new development.

Adjusting fees brings them into alignment with current economic realities and ensures that revenue keeps pace with expenditures. A total of \$100,000 is requested for a joint study of Citywide User Fees and an update to both the Park and the Traffic Impact Fees. Future revenues collected from these updates will recover the cost of these efforts.

**Police Department: Digital Forensics Lab (\$15,000):** Increasingly, evidence stored by the Police Department is in the form of digital information from cell phones, laptops, and the internet. To ensure digital records are securely stored, maintain legally defensible chains of custody, and protect against hacking and other cyber intrusions, the Department is requesting \$15,000 to upgrade its Digital Forensics Lab. These funds would be used to procure, replace, and upgrade specialized equipment necessary to ensure the lab continues to function effectively, and remain aligned with current investigative and evidentiary standards.

**Police Department: Civic Plus NextRequest Document Management (\$16,300):** NextRequest is a cloud-based, public records request software designed for government agencies to manage public records requests from submission to fulfillment. It acts as a centralized portal that streamlines workflows, reduces compliance risks, and provides a transparent way for the public to request, view, and receive documents.

Requests processed through the portal enhance efficiency and allow for a more streamlined process. Automating the public records request process significantly reduces the burden on staff, allowing them to focus on more critical tasks that require human insight and judgment. The portal also helps staff address challenges such as managing the volume and complexity of requests, tracking requests, decentralization, concerns around data security, and redaction capabilities. This system would be designed specifically to meet federal and state security and privacy standards for policing agencies. This system will also be coordinated with the City Clerk's Document Management System upgrade to ensure all systems work seamlessly.

**Fire Department: Local Hazard Mitigation Plan (\$100,000 with FEMA grant potentially paying 75%, with remaining \$25,000 from the General Fund):** Local governments are required to have an approved Local Hazard Mitigation Plan in place to receive pre-disaster and post-disaster mitigation federal funding. The City's Local Hazard Mitigation Plan (LHMP) was last approved by FEMA on May 2022 and must be updated every five years. Thus, an LHMP Update must be submitted to FEMA before May 2027. The LHMP update is to address modern threats to the community and to adhere to federal standards and guidelines.

The City is currently in the process of securing a FEMA grant that can fund up to 75% of its total eligible cost, with the remaining 25% to be funded by the City. FEMA can fund most activities related to developing or updating the LHMP. All grant documents have been submitted, and the approval of its sub-application is pending. The preliminary cost for securing a contractor specializing in the LHMP update is approximately \$100,000. The FEMA share, if approved, could be up to \$75,000 of the project's total cost. After the LHMP update has been completed, an estimated \$5,000 is planned for its ongoing maintenance annually.

**Public Works Services Department: Arborist (\$202,100):** The establishment of an Arborist position is necessary to ensure continued management of the City's urban forestry program and to maintain a healthy and sustainable tree population, while reducing risks associated with tree-related hazards. The Arborist function has traditionally been an ancillary responsibility of the Streets Superintendent in the Public Works Services Department; however, as the City's urban forest matures and legal requirements become more complex, a dedicated position is more essential to reduce risk and better manage the health of City trees. This position would be responsible for conducting systematic assessments of trees for structural integrity and potential safety concerns, maintaining comprehensive inventories of tree species and conditions, and developing long-term strategies for urban forestry management and infrastructure protection.

The Arborist would also play a critical role in planning and implementing preventative maintenance programs designed to promote tree health, extend asset life, and minimize conflicts with public infrastructure. In addition, following major storm events or emergency conditions, having an in-house arborist would ensure timely inspections and expert evaluation of damaged or hazardous trees. This capability would allow for informed and efficient decision-making regarding the removal or mitigation of dangerous trees, thereby enhancing public safety and improving the City's overall emergency response capacity.

**Development Services Department: Downtown Parking Study (\$29,500):** The proposed parking study would evaluate current parking patterns within the Downtown area and assess the effectiveness of existing timed parking regulations in light of significant private development that is either underway or nearing completion. The study would also consider whether adjustments to parking time

limits and management strategies are warranted to better accommodate changing demand conditions.

Following the opening of the A Line, ridership increased significantly, with the parking structure adjacent to the Transit Plaza frequently reaching capacity on most days of the week, approximately three years after commencement of service. In June 2019, when LA Metro implemented parking fees at its facilities, some transit users began shifting to free on-street parking in surrounding neighborhoods and City-owned parking lots within the Downtown area. In response, additional 4-hour parking restrictions were implemented on streets adjacent to the A Line station and within Downtown parking areas to help manage spillover demand.

Given the continued evolution of the area, including the near completion of developments such as the Alexan Azalea Apartments, the anticipated Alexan Arroyo project, and other future private developments, it is timely to update the 2019 Downtown Parking Study. In addition, the A Line has expanded eastward again, potentially changing parking patterns near stations along the route. The updated analysis would ensure that parking policies remain aligned with current and projected demand, support economic development, and maintain accessibility within the Downtown core.

**Recreation and Community Services Department: Lunar New Year Red Envelope (\$7,000):** During the Lunar New Year period, it is traditional for friends, families, and organizations to exchange red envelopes to celebrate and bring goodwill in the coming year. With this new program, the City of Arcadia would participate in this cultural tradition by providing patrons who visit a City facility with a specially designed red envelope that includes a message and a coupon for a giveaway. Giveaways could include items such as an Arcadia sticker, gift certificates to local businesses, or themed merchandise. Gift amounts would be nominal in value but could be enhanced with support from local businesses.

The table below summarizes the New Programs included in this proposed budget.

## NEW PROGRAMS

Proposed New Programs	FY 2026-27 Start Up Costs	Ongoing Annual Costs
<b>City Clerk</b>		
Public Records Software	\$ 20,000	\$ 20,000
Document Management	40,000	40,000
<b>Administrative Services</b>		
IT Coordinator	30,300	32,000
User and Impact Fee Updates	100,000	-
<b>Police</b>		
Digital Forensics Lab	15,000	15,000
Civic Plus - Document Management	16,300	15,000
<b>Fire</b>		
Local Hazard Mitigation Plan	25,000	
<b>Public Works Services</b>		
Arborist	202,100	208,500
<b>Development Services</b>		
Downtown Parking Study	29,500	
<b>Recreation Services</b>		
Lunar New Year Red Envelopes	7,000	15,000
<b>Total New Programs</b>	<b>485,200</b>	<b>345,500</b>

### **Capital Improvement and Equipment Replacement Funds**

The City strategically allocates resources to the Capital Improvement Fund and the Equipment Replacement Fund to support significant, non-recurring expenditures that occur on an intermittent basis. The balances in these funds have been reinforced over time through prudent fiscal management and the transfer of year-end General Fund surpluses. The City's ongoing objective is to maintain annual General Fund contributions at a level consistent with the 10-year average expenditures from each respective fund, thereby ensuring long-term funding stability and continuity.

This proactive funding approach is essential to preserving the integrity of the City's infrastructure systems and ensuring that staff have the necessary capital assets and equipment to provide essential services. For the FY 2026-27 Budget, a total transfer of \$4.8 million from the General Fund is proposed, with \$2.9 million allocated to the Capital Improvement Fund and \$1.9 million allocated to the Equipment Replacement Fund. Collectively, these amounts reflect the 10-year average expenditure levels for these funds.

The FY 2026-27 Capital Improvement Plan entails 35 projects, with a total expenditure of \$17.3 million. Of this amount, \$7.3 million will be funded from the Capital Improvement Fund. The Capital Improvement Fund primarily supports crucial maintenance initiatives such as pavement rehabilitation, building repairs, and parks maintenance. The following table provides a summary of the major projects proposed for the upcoming year.

**FY 2026-27 MAJOR CAPITAL IMPROVEMENT PROJECTS**

<b>Project Description</b>	<b>Project Budget</b>	<b>Funding Source</b>
<b>Sewer Main Replacement</b>	\$1,350,000	Sewer Fund
<b>Arboretum Sewer Project</b>	\$1,000,000	Sewer Fund
<b>Pavement Rehabilitation Program</b>	\$2,500,000	Capital Improvement \$1.0M & RMRA (SB1) - \$1.5M
<b>LED Lighting Conversion</b>	\$1,120,000	Capital Improvement Fund
<b>Annual Slurry Seal Program</b>	\$1,400,000	Capital Improvement Fund
<b>Downtown Parking Lot</b>	\$1,150,000	Capital Improvement Fund

The Equipment Replacement Fund plays a critical role in funding essential equipment, such as computers, vehicles, and major office equipment. The budgeted annual transfer of \$1.9 million properly funds current spending levels and allows the City to replace equipment before it becomes obsolete.

In the proposed budget, there are several vehicle replacements planned – specifically, heavy-duty vehicles used by the Public Works Services and Police Departments. In addition, there is a project to upgrade the Police Department’s computer dispatch and records management (CAD/RMS) software that is critical to maintaining reliable operations, compliance, and interoperability with regional partners.

The Equipment Replacement Fund encompasses a comprehensive list of 30 equipment purchases, totaling \$6.9 million. Sixty-four percent (64%) of the \$6.9 million (or \$4.4 million) will be funded by the Equipment Replacement Fund. The table below summarizes some significant equipment purchases for the upcoming period.

**FY 2026-27 MAJOR EQUIPMENT REPLACEMENT PURCHASES**

<b>Equipment Replacement Description</b>	<b>Replacement Budget</b>	<b>Funding Source</b>
<b>Water Vehicle Replacements:</b>		
<ul style="list-style-type: none"> <li>• Crane Truck</li> <li>• Heavy Duty Dump Truck</li> <li>• Compact Pickup Truck</li> <li>• ¾ Ton Pickup Truck</li> <li>• Installation of Equipment and Accessories</li> </ul>	\$932,400	Water Fund
<b>Police Department:</b>		
<ul style="list-style-type: none"> <li>• 2 New Patrol Vehicles</li> <li>• ½ Ton Pickup Truck</li> <li>• Radio Replacement</li> <li>• Installation of Equipment and Accessories</li> </ul>	\$286,300	Equipment Replacement

**FY 2026-27 MAJOR EQUIPMENT REPLACEMENT PURCHASES**

<b>Equipment Replacement Description</b>	<b>Replacement Budget</b>	<b>Funding Source</b>
<b>Police Department:</b>		
<ul style="list-style-type: none"> <li>CAD/RMS Upgrade</li> </ul>	\$1,500,000	Equipment Replacement
<b>Police Department:</b>		
<ul style="list-style-type: none"> <li>Reconstruction of Radio Communication Tower</li> </ul>	\$1,321,100	Equipment Replacement/Insurance
<b>Streets Vehicle Replacements:</b>		
<ul style="list-style-type: none"> <li>2 ¾ Ton Pickup</li> <li>New CNG Street Sweeper</li> <li>Installation of Equipment and Accessories</li> </ul>	\$926,800	Equipment Replacement

**OVERALL ECONOMIC OUTLOOK**

The General Fund FY 2026–27 Operating Budget was developed based on expectations of moderate and steady economic growth, although broader economic conditions are anticipated to remain uncertain and uneven throughout the Fiscal Year. Economic forecasting for FY 2026–27 has proven challenging due to the presence of conflicting economic indicators regarding the overall direction of the economy. While certain measures, including employment levels, consumer spending, and property valuations have continued to demonstrate relative strength and stability, other indicators have reflected slowing economic growth, persistent inflationary pressures, elevated interest rates, and increased market volatility.

Additional external factors, including geopolitical uncertainty, global trade concerns, supply chain adjustments, and fluctuations in energy prices, are also expected to continue contributing to economic uncertainty. Consumer spending patterns have shown signs of moderation as households continue adjusting to higher living costs and changing financial conditions. Collectively, these factors have created an economic environment in which long-term trends and revenue projections have become more difficult to evaluate with a high degree of certainty.

Despite these uncertainties, the overall economic outlook is expected to remain generally stable, with moderate growth anticipated during Fiscal Year 2026–27. Nevertheless, the proposed budget has been prepared using conservative forecasting assumptions intended to preserve fiscal stability, maintain operational flexibility, and position the City to respond appropriately to evolving economic conditions throughout the Fiscal Year.

The City’s General Fund reserve has grown over the past several fiscal years, increasing from approximately \$30.5 million in Fiscal Year 2020–21 to \$82.9 million in Fiscal Year 2024-25. This substantial growth reflects the City’s long-term focus and fiscal prudence. Maintaining healthy reserve levels strengthens the City’s financial stability and provides flexibility to address unforeseen expenses, economic uncertainty, or revenue shortfalls. As a result, the City is well-positioned to weather potential economic downturns while continuing to maintain essential services and respond to community needs.

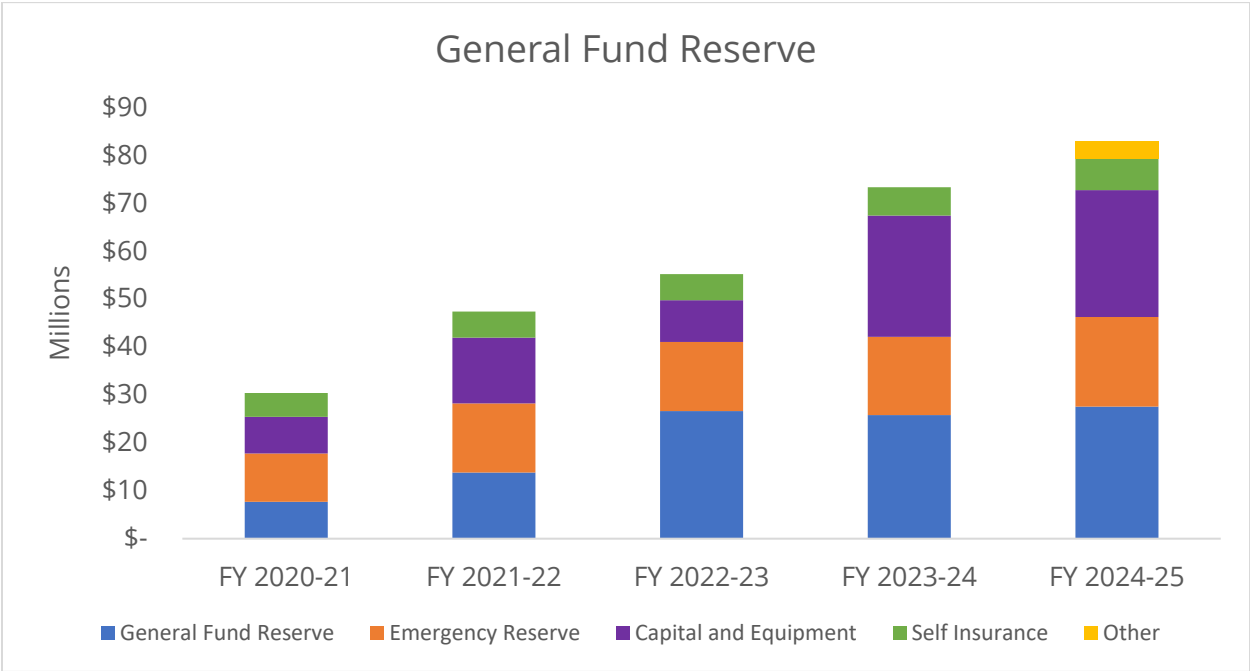

## **CONCLUSION**

The proposed FY 2026-27 General Fund Operating Budget demonstrates a balanced financial position, with a projected surplus of \$276,000. This surplus is the result of Total Operating Revenues and Transfers In, amounting to \$106.1 million, net of Operating Expenditures and Transfers Out, totaling \$105.8 million.

Arcadia's commitment to careful budgeting has resulted in a strong financial buffer, positioning the City to better withstand periods of short-term economic uncertainty. The General Fund reserve balance, at approximately \$21.5 million, provides the City with the flexibility needed to respond to unforeseen events and emerging fiscal challenges. The City's ability to sustain essential services during periods of economic volatility reflects its fiscal discipline, adaptability, and commitment to maintaining service continuity for residents and businesses.

Looking ahead, these foundational strengths are expected to be maintained by the City's management team through continued prudent financial planning and disciplined resource allocation. As a result, the City is expected to remain well-positioned to deliver effective, efficient, and fiscally responsible municipal services, while maintaining long-term financial stability.

To move forward with the proposed budget and ensure effective financial planning, it is recommended that the City Council adopt the proposed resolutions, which include enacting the FY 2026-27 Operating Budget as well as the Five-Year Capital and Equipment Replacement Plans.

Attached to this staff report are the following:

- Exhibit "A": A summary of Sources and Uses for All Funds reflecting the proposed FY 2026-27 Operating Budget presented to City Council for adoption.
- Exhibit "B": A summary of the proposed Five-Year Capital Improvement and Equipment Replacement Plan.

## **ENVIRONMENTAL ANALYSIS**

The proposed actions do not constitute a project under the California Environmental Quality Act ("CEQA"), based on Section 15061(b)(3) of the CEQA Guidelines, as it can be seen with certainty that they will have no impact on the environment.

Many of the budgeted items in the attached documents may require their own environmental review, which will be conducted when each project is brought forward for consideration.

## **FISCAL IMPACT**

The General Fund Operating Fund Balance is projected to reach \$21.0 million by the end of FY 2025-26, providing the necessary reserves to sustain operations throughout the Fiscal Year.

The proposed budget is balanced, with revenues exceeding expenditures by \$276,000. In accordance with the City's financial policies, which recommend maintaining a 20% balance in the Emergency Reserve Fund relative to annual operating expenditure, a transfer of \$427,000 is expected to be made to the Emergency Reserve Fund at the conclusion of FY 2025-26. In total, the City has \$82.9 million in unrestricted reserve funds to address future needs, emergencies, and unexpected circumstances that may arise in the future.

## **RECOMMENDATION**

It is recommended that the City Council determine these actions do not constitute a project under the California Environmental Quality Act ("CEQA"); and:

- 1) Adopt Resolution No. 7696 adopting a Budget for Fiscal Year 2026-27 and appropriating the amounts specified therein as expenditures from the various funds; and
- 2) Adopt Resolution No. 7697 adopting a Capital Improvement and Equipment Plan for Fiscal Years 2026-27 through 2030-31.

Attachments: Resolution No. 7696

Resolution No. 7697

Exhibit "A" – All Funds Fiscal Year 2026-27 Operating Budget Summary

Exhibit "B" – Five-Year Summary of Capital and Equipment Plan

RESOLUTION NO. 7696

A RESOLUTION OF THE CITY COUNCIL OF THE CITY OF ARCADIA, CALIFORNIA, ADOPTING A BUDGET FOR FISCAL YEAR 2026-2027 AND APPROPRIATING THE AMOUNTS SPECIFIED THEREIN AS EXPENDITURES FROM THE VARIOUS FUNDS

WHEREAS, on June 2, 2026, the City Manager submitted to the City Council a proposed Budget for Fiscal Year 2026-2027, a copy of which is on file in the Office of the City Clerk; and

WHEREAS, Section 1204 of the Arcadia City Charter requires notice and hearing for consideration of a proposed operating budget and its adoption by resolution; and

WHEREAS, the aforementioned proposed Budget includes the budget for the ensuing Fiscal Year 2026-2027; and

WHEREAS, notice of the public hearing on the proposed Budget and a summary of the proposed Budget were published on May 22, 2026; and

WHEREAS, the duly noticed public hearing was conducted by the City Council on June 2, 2026.

NOW, THEREFORE, THE CITY COUNCIL OF THE CITY OF ARCADIA, CALIFORNIA, DOES HEREBY FIND, DETERMINE AND RESOLVE AS FOLLOWS:

SECTION 1. That certain "City of Arcadia Budget, Fiscal Year 2026-2027", as on file in the office of the City Clerk, together with any approved amendments thereto, is hereby adopted, in pertinent part, as the official budget of the City of Arcadia for

the Fiscal Year 2026-27 and the amounts specified therein as expenditures from the funds indicated are hereby appropriated for the purposes specified therein.

SECTION 2. The City Clerk shall certify to the adoption of this Resolution.

Passed, approved and adopted this 16th day of June, 2026.

\_\_\_\_\_  
Mayor of the City of Arcadia

ATTEST:

\_\_\_\_\_  
City Clerk

APPROVED AS TO FORM:

  
\_\_\_\_\_  
Michael J. Maurer  
City Attorney

RESOLUTION NO. 7697

A RESOLUTION OF THE CITY COUNCIL OF THE CITY OF ARCADIA, CALIFORNIA, ADOPTING A CAPITAL IMPROVEMENT AND EQUIPMENT PLAN FOR FISCAL YEARS 2026-2027 THROUGH 2030-2031

WHEREAS, on June 2, 2026, the City Manager submitted to the City Council a proposed plan entitled, "Capital Improvement and Equipment Plan, Fiscal Years 2026-2031", a copy of which is on file in the office of the City Clerk; and

WHEREAS, Section 1205 of the Arcadia City Charter requires notice and hearing for the consideration of a capital program and its adoption by resolution of the City Council; and

WHEREAS, notice of the public hearing on the proposed Capital Improvement and Equipment Plan was published on May 22, 2026; and

WHEREAS, the duly noticed public hearing was conducted by the City Council on June 2, 2026.

NOW, THEREFORE, THE CITY COUNCIL OF THE CITY OF ARCADIA, CALIFORNIA, DOES HEREBY FIND, DETERMINE AND RESOLVE AS FOLLOWS:

SECTION 1. That certain "Capital Improvement and Equipment Plan, Fiscal Years 2026-2031", as on file in the office of the City Clerk, together with any approved amendments thereto, is hereby adopted, in pertinent part, for Fiscal Year 2022-2027.

SECTION 2. The City Clerk shall certify to the adoption of this Resolution.

Passed, approved and adopted this 16th day of June, 2026.

\_\_\_\_\_  
Mayor of the City of Arcadia

ATTEST:

\_\_\_\_\_  
City Clerk

APPROVED AS TO FORM:

  
\_\_\_\_\_  
Michael J. Maurer  
City Attorney

**Exhibit "A"**

**CITY OF ARCADIA  
SUMMARY BY FUND  
FISCAL YEAR 2026-2027 PROPOSED BUDGET**

Fund	SOURCES OF FUNDS				USES OF FUNDS			Ending Fund Balance FY
	Beginning Fund FY	Outside Sources	Transfer In	Total	Appropriation	Transfer Out	Total	
General Fund	21,454,300	96,563,100	9,516,000	127,533,400	100,091,100	5,712,000	105,803,100	21,730,300
Narcotic Seizure Federal	227,000	21,800	0	248,800	0	0	0	248,800
COPS	311,600	207,800	0	519,400	215,600	0	215,600	303,800
Medical/Dental	490,700	0	4,432,000	4,922,700	4,200,000	2,000	4,202,000	720,700
Local Law Enforcement	900	155,800	155,800	312,500	311,600	0	311,600	900
IRS Task Force	517,800	17,900	0	535,700	0	0	0	535,700
Worker Compensation/Liability	5,918,400	147,000	3,585,000	9,650,400	4,179,600	0	4,179,600	5,470,800
Homeland Security	0	100,000	0	100,000	100,000	0	100,000	0
Library State Grant	600	0	0	600	0	0	0	600
Homelessness Plan	2,500	318,000	0	320,500	318,000	0	318,000	2,500
Office of Traffic Safety Grant	3,400	110,000	0	113,400	110,000	0	110,000	3,400
California OES HSGP	(32,500)	75,000	0	42,500	50,000	0	50,000	(7,500)
Autotheft Prevention Taskforce	0	0	0	0	0	0	0	0
Emergency Reserve	18,737,800	0	0	18,737,800	0	0	0	18,737,800
America Rescue Plan Act	0	0	0	0	0	0	0	0
Public, Educational/Governmental Access	1,396,600	99,900	0	1,496,500	15,000	0	15,000	1,481,500
Parks & Recreation	6,218,400	1,674,200	0	7,892,600	0	0	0	7,892,600
Fire Facilities Fund	460,500	136,500	0	597,000	0	0	0	597,000
Used Oil Grant	17,800	8,300	0	26,100	8,200	0	8,200	17,900
DOC Beverage Grant	80,100	16,200	0	96,300	14,100	0	14,100	82,200
Traffic Safety	0	142,800	0	142,800	0	142,800	142,800	0
Solid Waste	2,751,600	910,500	0	3,662,100	609,300	300,000	909,300	2,752,800
Measure W - Safe Clean Water Program	4,222,300	1,122,800	0	5,345,100	2,037,800	0	2,037,800	3,307,300
Dow Settlement Fund	14,111,800	423,400	0	14,535,200	0	0	0	14,535,200
State Gas Tax	12,100	1,646,700	0	1,658,800	104,500	1,600,000	1,704,500	(45,700)
Road Maintenance/Rehabilitation Act	2,471,700	1,657,700	0	4,129,400	1,500,000	0	1,500,000	2,629,400
Air Quality Management District	278,400	81,900	0	360,300	62,700	0	62,700	297,600
Community Development Block Grant	0	260,000	0	260,000	257,600	0	257,600	2,400
Santa Anita Grade Separation	824,600	20,600	0	845,200	0	0	0	845,200
Transit	0	3,849,800	663,400	4,513,200	3,845,500	0	3,845,500	667,700
Proposition A	5,049,900	1,569,200	0	6,619,100	447,800	1,498,900	1,946,700	4,672,400
Transportation Impact Fund	684,500	417,100	0	1,101,600	659,900	0	659,900	441,700
TDA Article 3 Bikeway	4,600	44,700	0	49,300	40,000	0	40,000	9,300
STPL & ITS Special Fund	0	0	0	0	0	0	0	0
Measure M	2,534,300	2,580,800	0	5,115,100	3,449,500	0	3,449,500	1,665,600
Capital Improvement	23,697,300	877,400	2,900,000	27,474,700	24,064,200	0	24,064,200	3,410,500
City Hall Reserve	100	0	0	100	0	0	0	100
Lighting Maintenance	310,900	1,542,300	922,600	2,775,800	1,537,700	0	1,537,700	1,238,100
Water Fund	(7,519,300)	19,445,000	0	11,925,700	20,513,400	0	20,513,400	(8,587,700)
Sewer Fund	8,535,400	3,019,900	0	11,555,300	4,646,200	0	4,646,200	6,909,100
Par 3 Golf Course Fund	3,124,700	1,819,200	0	4,943,900	1,569,000	0	1,569,000	3,374,900
Equipment Replacement	18,281,500	1,508,400	1,900,000	21,689,900	5,583,200	36,600	5,619,800	16,070,100
Redevelopment Successor Agency	233,000	2,430,600	0	2,663,600	2,663,600	0	2,663,600	0
General Obligation Bond 2012	400,600	410,000	0	810,600	410,100	0	410,100	400,500
General Obligation Bond 2011	554,500	534,600	0	1,089,100	524,400	0	524,400	564,700
Pension Obligation Bonds 2020	0	5,874,600	0	5,874,600	5,874,600	0	5,874,600	0
<b>Total</b>	<b>144,415,000</b>	<b>154,075,700</b>	<b>24,074,800</b>	<b>322,565,500</b>	<b>195,922,900</b>	<b>10,484,100</b>	<b>206,407,000</b>	<b>116,158,500</b>

**Exhibit "B"**

CITY OF ARCADIA  
 SUMMARY OF PROPOSED FIVE YEAR CAPITAL PROGRAMS  
 FISCAL YEAR 2026-27 THROUGH 2030-31

	ESTIMATED FUNDS 7/01/2026	ESTIMATED FIVE-YEAR REVENUE	PROPOSED FIVE-YEAR EXPENDITURE	ESTIMATED FUNDS 6/30/2031
CAPITAL OUTLAY FUND	23,697,300	25,034,500	(38,093,700)	10,638,100
AMERICAN RESCUE PLAN FUND	3,042,700	-	(3,042,700)	-
PARK AND RECREATION FUND	6,218,400	6,291,800	(7,900,000)	4,610,200
FIRE FACILITIES FUND	460,500	613,700	-	1,074,200
MEASURE W CLEAN, SAFE WATER PROGRAM	4,222,300	5,523,100	(5,960,800)	3,784,600
GAS TAX (HUTA) FUND	12,100	8,256,200	(8,122,500)	145,800
ROAD MAINTENANCE AND REHABILITATION PROGRAM	2,471,700	8,351,600	(6,600,000)	4,223,300
AQMD	278,400	415,600	(153,500)	540,500
PROP C LOCAL RETURN	4,478,000	6,194,800	(10,077,900)	594,900
TRANSPORTATION IMPACT FUND	684,500	1,324,300	(959,900)	1,048,900
MEASURE R LOCAL RETURN	1,104,500	4,516,100	(8,648,700)	(3,028,100)
MEASURE M LOCAL RETURN	2,534,300	6,837,600	(7,319,500)	2,052,400
WATER FACILITY RESERVE	11,445,900	275,600	(19,883,900)	(8,162,400)
WATER EQUIPMENT RESERVE	(1,989,400)	-	(2,274,500)	(4,263,900)
SEWER FUND	8,535,400	15,143,000	(22,332,100)	1,346,300
EQUIPMENT FUND	18,281,500	11,884,600	(22,510,500)	7,655,600

**DATE:** June 16, 2026

**TO:** Honorable Mayor and City Council

**FROM:** Lisa L. Flores, Development Services Director  
By: Edwin Arreola, Senior Planner

**SUBJECT:** APPEAL NO. 26-01 - A REQUEST TO OVERTURN THE PLANNING COMMISSION'S DENIAL OF MULTI-FAMILY SB 330 APPLICATION NO. SB 330 25-01, TENTATIVE TRACT MAP NO. TTM 26-01 (84910), AND PROTECTED HEALTHY TREE REMOVAL NO. TRH 26-02 FOR A NEW 30 UNIT, MULTI-FAMILY RESIDENTIAL CONDOMINIUM DEVELOPMENT LOCATED AT 514 FAIRVIEW AVENUE; AND CONSIDERATION OF RESOLUTION NO. 7699 - APPROVING APPEAL NO. 26-01

**CEQA: Exempt**

**Recommendation: Adopt**

### **SUMMARY**

The Appellant, Eric Tsang, on behalf of the property owner 518 Fairview LLC, is appealing the Planning Commission's denial of Multi-Family SB 330 Application No. SB 330 25-01, Tentative Tract Map No. TTM 26-01 (84910), and Protected Healthy Tree Removal Permit No. TRH 26-02, for a new 30 unit, contemporary style, multi-family residential condominium development and the removal of 11 protected trees, located at 514 Fairview Avenue ("Project").

During the April 28, 2026, Planning Commission Meeting, the Commission voted 4-1 to deny the Project, with Commissioner Wilander dissenting on the basis that the mass of the building was not compatible with the surrounding developments, directing staff to return with a revised resolution. At the May 12, 2026, Planning Commission Meeting, the Commission voted 3-2 to deny the Project, with Commissioners Wilander and Hui dissenting.

The proposed development and subdivision are consistent with the City's General Plan, Development Code, and the Subdivision Code. In addition, it meets Senate Bill 330 requirements and is subject to objective development standards. As such, the project may only be denied based on specific, identifiable health and safety concerns. It is recommended that the City Council find that the Project is Categorically Exempt under the California Environmental Quality Act ("CEQA") under Section 15332 as a Class 32 infill development, overturn the Planning Commission's denial of the Project, and adopt Resolution No. 7699 approving Appeal No. 26-01, subject to the conditions listed in the staff report – refer to Attachment No. 1.

## **BACKGROUND**

The subject site is located on the south side of Fairview Avenue and consists of two existing residential lots (514 and 518 Fairview Avenue). The 514 Fairview Avenue lot is 28,870 square feet and the 518 Fairview Avenue lot is 28,925 square feet. Together, the site has a total area of approximately 57,795 square feet and is zoned High Density Residential (R-3) with a General Plan Land Use Designation of High Density Residential. Surrounding land uses also include other R-3 zoned properties to the north, east, south, and west. The Project site currently consists of a 1,672 square foot home, a 1,044 square foot home, a 738 square foot home, and several storage and barn structures – refer to Figure 1 below and Attachment No. 2 for an Aerial Photo with Zoning Information and Photos of the Subject Property and Vicinity.

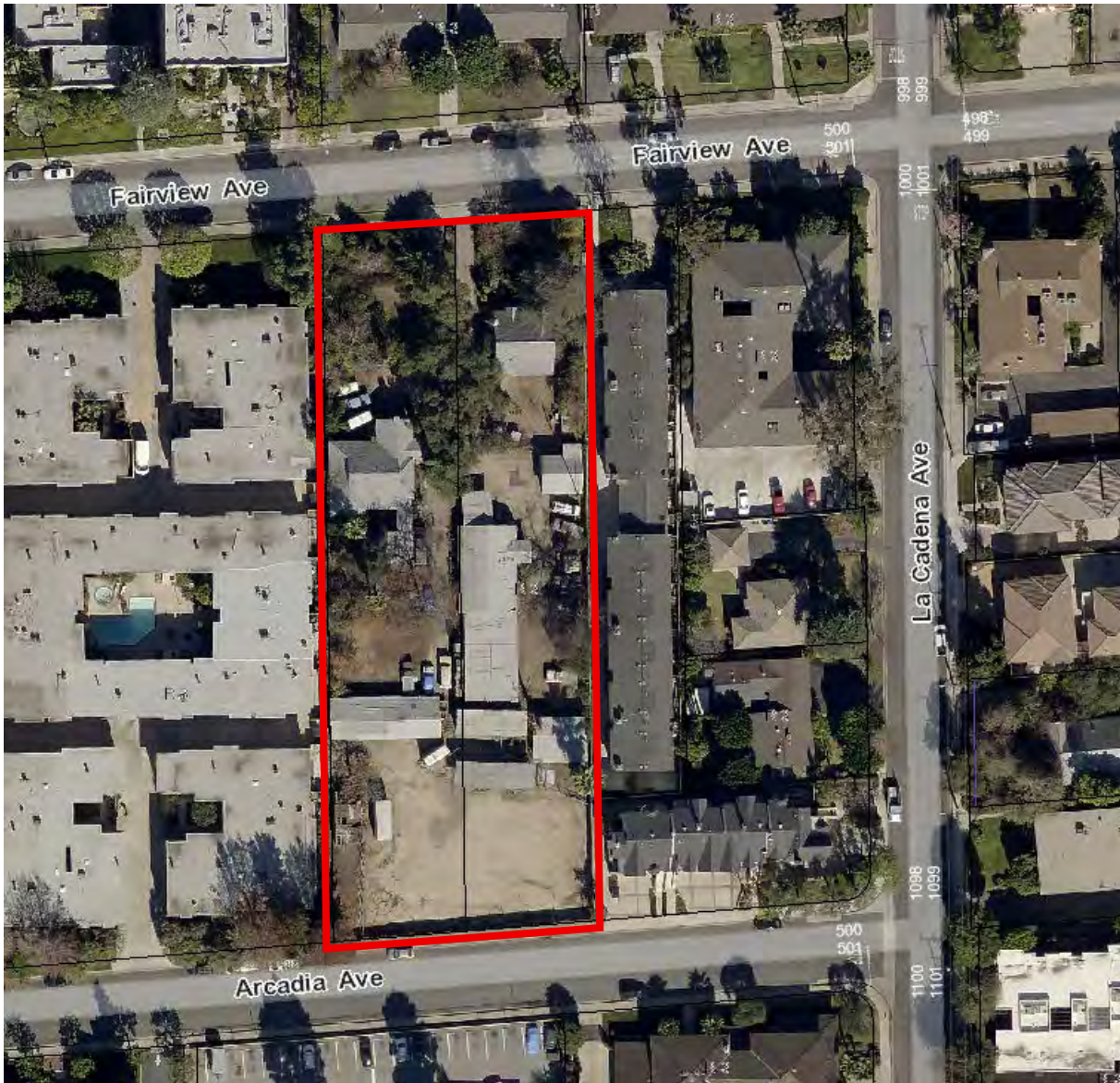

**Figure 1** – Aerial of the Subject Site

The Project received preliminary approval through the SB 330 process under SB 330 Preliminary Application No. SB 330 PRELIM 25-04, which streamlines the review and approval of housing projects that comply with all zoning regulations and objective development standards in the Development Code. SB 330, enacted as part of the Housing Crisis Act of 2019, was subsequently amended by SB 8 (2022) and AB 1218 (2024) to further facilitate housing production.

Because the Project's SB 330 Preliminary Application was submitted on June 26, 2025, all applicable standards in effect at that time were vested. Accordingly, the Project is subject only to objective development standards, is not subject to design review, and is limited to no more than five public hearings. In addition, because the application was submitted prior to the effective date of the City's Inclusionary Housing Ordinance on July 1, 2025, the Project is *not* required to provide affordable units. The Project is not utilizing the State Density Bonus Law.

### Planning Commission Meetings

At the April 28, 2026, Planning Commission Meeting, the Commission considered the Tentative Tract Map and the removal of 11 protected trees to accommodate the 30-unit, contemporary style, multi-family residential development.

During the meeting, significant discussion focused on SB 330, the Applicant's requests for waivers from certain objective development standards in the Development Code, and the Project's compatibility with the surrounding neighborhood (see Attachment No. 5, Planning Commission Minutes dated April 28, 2026, and Resolution No. 2187).

As discussed during the hearing, the requested waivers are authorized under the City's Development Code and independent of any requirements imposed by SB 330. The waiver provisions allow limited flexibility from specified objective development standards when strict application of those standards may not achieve the highest-quality or most cohesive project design. Applicants may request waivers with supporting justification, and those requests are evaluated based on the findings and criteria established in the Development Code.

The Development Services Director and Assistant City Attorney advised the Planning Commission that the Housing Accountability Act ("HAA") limits a local agency's ability to deny or reduce the density of a housing development that complies with all applicable objective standards. Under State law, a compliant housing project may be denied only if substantial evidence demonstrates that the project would result in a specific, adverse impact on public health or safety and there is no feasible method to mitigate or avoid that impact. The City Attorney reiterated this legal standard at the Commission's subsequent meeting on May 12, 2026.

The City received five letters in opposition to the Project (refer to Attachment No. 6), and two residents spoke in opposition at the hearing. Several Commissioners expressed concerns regarding the Project's massing and concluded that it was incompatible with the surrounding neighborhood. Following discussion, the Commission voted 4-1 to deny the Project, with Commissioner Wilander dissenting, and directed staff to return with a resolution reflecting its action at the May 12, 2026, meeting.

Following the April 28, 2026, Planning Commission meeting, the City Manager sent a letter to the Planning Commission explaining that denial of an SB 330 housing project based on subjective considerations, such as perceived scale or neighborhood character, is generally not supported under State law and could expose the City to significant legal and financial risks (Attachment No. 4).

At the May 12, 2026, meeting, two resolutions were presented: one resolution approving the Project should the Planning Commission choose to reconsider its prior action, and a second resolution reflecting the Commission's direction to deny the Project. The Commission was advised that, if they chose to deny the Project, it should identify specific adverse public health or safety impacts and include objective, quantifiable evidence in the record to support the required findings.

The Planning Commission voted 3-2 to deny the Project, with Commissioners Wilander and Hui dissenting – refer to Attachment No. 3 for Resolution No. 2187. During discussion, the three Commissioners that voted to deny the Project stated that they could not identify any specific adverse public health or safety impacts associated with the Project and instead based their decision on concerns related to the Project's compatibility with the surrounding neighborhood.

On May 15, 2026, within the applicable 10-day appeal period, the Appellant filed an appeal of the Planning Commission's decision.

Subsequent to the Planning Commission's action, the California Department of Housing and Community Development (“HCD”) contacted the City regarding a potential violation of the Housing Accountability Act (HAA). City staff met with HCD to discuss the matter, and HCD indicated that it will continue to monitor the City's actions related to the Project.

## **DISCUSSION**

The Appellant proposes to merge the two existing lots through the Tentative Tract Map process and develop a contemporary-style multi-family project consisting of 30 condominium units. The Tentative Tract Map would also establish airspace subdivisions for each unit to facilitate the sale of individual residential condominiums.

To allow for separate ownership and sale of the condominium units, approval of a Tentative Tract Map establishing airspace subdivisions is required. While SB 330 streamlines the review of qualifying housing developments, it does not eliminate the requirement for subdivision maps or modify the procedures applicable to their review and approval. Accordingly, the Tentative Tract Map remains subject to review and approval by the Planning Commission at a public hearing.

The proposed 30 units will be constructed as 15 buildings, each containing two attached townhouse-style units. Each building includes one of two distinct floor plan types. Model A consists of a 1,855-square-foot, four-bedroom unit, and Model B consists of a 1,867-square-foot, four-bedroom unit. Each building will reach the maximum allowed height of 30 feet as permitted by the Code for properties zoned R-3, High Density Residential. The Project complies with all setback requirements, and each unit will include a two-car garage.

### Appellant's Basis for Appeal

The Appellant has appealed the Planning Commission's decision to deny the Project, asserting that the denial constitutes an abuse of discretion, is not supported by substantial evidence in the administrative record, and is inconsistent with applicable State housing laws. In the appeal letter dated May 15, 2026 (Attachment No. 3), the Appellant requests that the Planning Commission's decision be overturned and identifies the following primary grounds for appeal:

1. The Project complies with the City's applicable objective development standards.
2. The Project is deemed consistent under the Housing Accountability Act ("HAA").

3. The Planning Commission improperly relied on subjective considerations in denying the Project.
4. The approved objective development standard waivers were properly granted through the administrative review process and were not subject to Planning Commission review.
5. The Planning Commission did not make the findings required under State law to support denial of a housing development project.
6. The Project is deemed approved under the Permit Streamlining Act.
7. Denial of the Project may conflict with the No Net Loss provisions of State Housing Element law.
8. Denial of the Project could expose the City to fines, penalties, and attorney's fees under State housing laws.
9. The Applicant has voluntarily proposed additional design refinements in response to concerns raised during the public review process.

The complete appeal letter is included as Attachment No. 3 and incorporated herein by reference. The architectural plans and tentative tract map for this Project can be found under Attachment Nos. 7 and 8.

#### Applicable State Housing Laws

The Housing Accountability Act ("HAA") limits a local agency's ability to disapprove of a housing development project or reduce its density when the project complies with applicable objective standards. Under State law, a compliant housing development may be denied only if the local agency makes specific written findings, supported by substantial evidence in the record, that the project would result in a specific, adverse impact upon public health or safety and that there is no feasible method to satisfactorily mitigate or avoid that impact.

Senate Bill 330 further limits the City's review of qualifying housing development projects by requiring application of the ordinances, policies, and standards in effect at the time a complete preliminary application was submitted.

### Project Compliance with Applicable Standards

Based on the City review of the Project and the applicable provisions of the General Plan, Development Code, and Subdivision Code, the Project complies with all applicable objective development standards, as modified by the approved waivers.

No substantial evidence was identified demonstrating that the Project would result in a specific, adverse impact upon public health or safety. Accordingly, the findings necessary to deny the Project under the Housing Accountability Act cannot be made.

Because the Project complies with applicable objective development standards, concerns regarding project design, neighborhood character, or compatibility that are not based on applicable objective standards cannot serve as a basis for denial under State housing law.

### Objective Development Standard Waivers

Arcadia Development Code Section 9102.01.170(C)(2) authorizes eligible multi-family residential projects to request waivers from up to three objective development standards, provided the Applicant demonstrates why a particular standard is not applicable or cannot be achieved. The Code further provides that such waiver requests are reviewed and approved by the Director or their designee as part of the administrative review process.

The waiver requests associated with this Project were reviewed pursuant to Section 9102.01.170(C)(2) and were determined to be appropriately justified and consistent with the intent of the applicable development standards. The waivers were approved during the administrative review process prior to consideration by the Planning Commission.

Because the Development Code assigns authority for these determinations to the Director or their designee and specifies that such decisions are not appealable, the approved waivers are not matters before the City Council as part of this appeal.

## Massing

The Appellant specifically challenges the Planning Commission's reference on the third-floor setback waiver as part of its rationale for denial, particularly in relation to building massing.

The applicable objective development standard requires portions of the third floor to be recessed a minimum of three feet from the lower floors to reduce perceived building mass. While the majority of the third floor complies with this requirement, certain limited areas provide a reduced setback ranging from approximately 1'-6" to less than 3'-0", with the remainder of the third floor maintaining the full three-foot setback, as shown in Figures 2, 3, and 4. This variation is provided to allow for adequate architectural articulation and to avoid a continuous, unbroken wall plane along the building elevation.

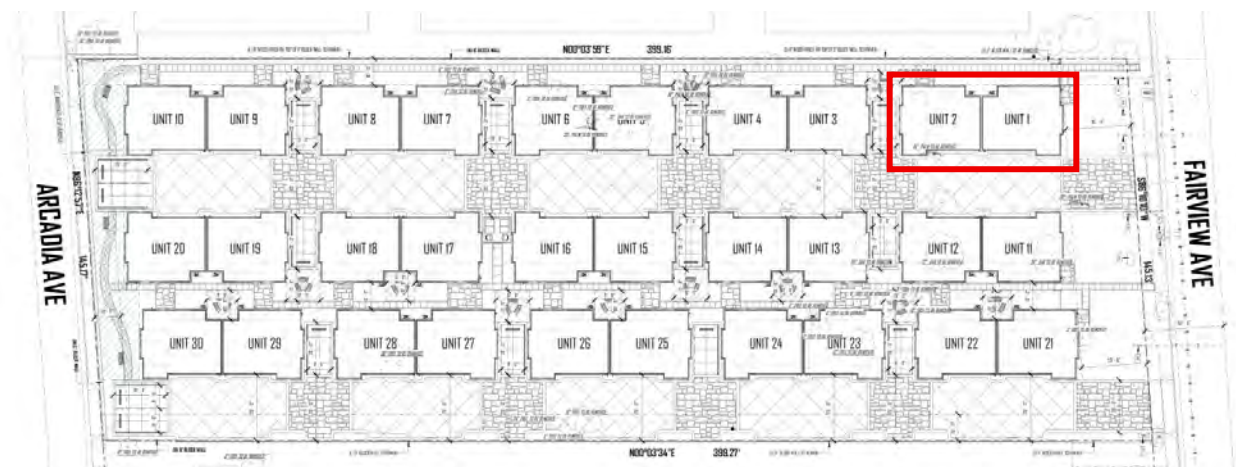

**Figure 2 (Key Map)** – This site plan indicating the location of the floor plan for Figure 3 below.

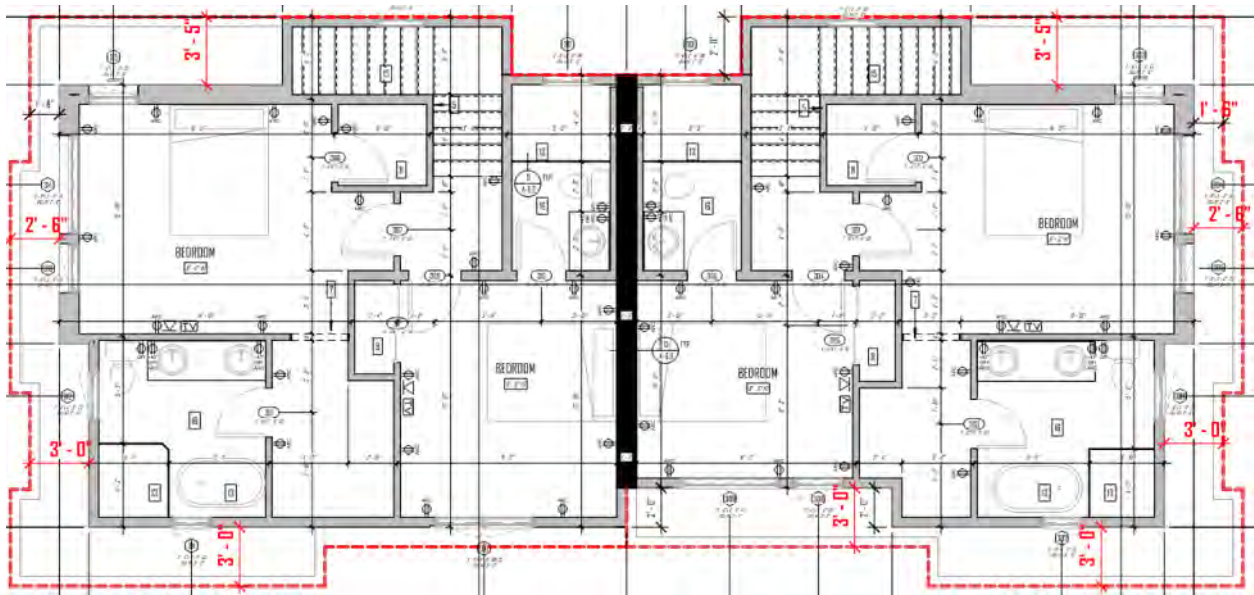

**Figure 3** – Third floor plan with the second-floor outline beneath (dashed in red)



**Figure 4** – Rendering of the units from Fairview Avenue with the third floor stepped back.

The areas that do not fully meet the third-floor setback requirement are limited to small portions of the façade where variations in the wall plane provide architectural articulation. The third floor is stepped back overall to transition appropriately to the

surrounding neighborhood and to avoid a continuous, unbroken wall plane, resulting in a building form that is not boxy in appearance – refer to the image above in Figure 4. As a result, the building maintains the appearance of a recessed third floor when viewed from the public right-of-way, consistent with the intent of the standard.

The Project also complies with the maximum height limit of 30 feet (or 33 feet if it has a pitched roof), which has been in effect since 2016. This height is consistent with other SB 330-approved multi-family projects in similar two- to three-story residential areas within the City.

#### Additional State Law Issues Raised by Appellant

The Appellant also raises issues related to project consistency under the Housing Accountability Act, the Permit Streamlining Act, the No Net Loss provisions of Housing Element law, and potential penalties under State housing laws. Based on the City's review of these issues, approval of the Project would be consistent with the City's obligations under applicable State housing laws. Because the Project complies with applicable objective standards and the findings required to support denial cannot be made, these additional legal issues do not alter the City's conclusion regarding the appeal.

### **FINDINGS**

Sections 9103.15.040 and 9105.03.060(A)(1) of the Development Code require that for a Tentative Tract Map to be granted, it must be found that all of the following prerequisite findings can be satisfied:

#### Tentative Tract Map

- 1. The proposed map, subdivision design, and improvements are consistent with the General Plan, any applicable specific plan, and the Subdivisions Division of the Development Code.**

**Facts to Support This Finding:** The Project is in compliance with all of the provisions of the City's General Plan, Subdivisions Division of the Development Code, and the State Subdivision Map Act. It has been determined that the proposed subdivision is consistent with the General Plan High Density Residential

Land Use designation and the R-3, High Density Multiple Family Residential zoning designation. These designations are intended to accommodate high density, attached or detached residential units such as condominiums, within the appropriate neighborhoods. The proposed Tentative Parcel Map complies with the Subdivision Map Act regulations, and there is no specific plan applicable to this Map. The site is physically suitable for the approved condominium project. The Map would not adversely affect the comprehensive General Plan and is consistent with the following General Plan goals and policy:

#### Land Use and Community Design Element

- Policy LU-1.1: Promote new infill and redevelopment projects that are consistent with the City's land use and compatible with surrounding existing uses.
- Policy H-2.3: Encourage compatible residential development in areas on underutilized land.
- Policy H-2.4: Maintain development standards, regulations, and design features that are flexible to provide a variety of housing types and facilitate housing that is appropriate for the neighborhoods in which they are located.
- Policy H-4.4: Support infill development at appropriate locations in the City.

#### **2. The site is physically suitable for the type and proposed density of development.**

**Facts to Support This Finding:** The R-3 Zone requires a minimum density of one dwelling unit per 2,200 square feet of lot area, and a maximum density of one unit per 1,450 square feet of lot area. Based on the lot area of 57,795 square feet, a minimum of 26 units and a maximum of 39 units could be developed at this site. Therefore, the proposed 30-unit development complies with the density requirements of the underlying zone, as well as all other applicable zoning requirements including but not limited to parking, setbacks, height, and open space. Therefore, the site is physically suitable for the Project.

- 3. The design of the subdivision and the proposed improvements are not likely to cause substantial environmental damage or substantially and avoidably injure fish or wildlife or their habitat.**

**Facts to Support This Finding:** The Project is a subdivision of an infill site within an urbanized area and does not serve as a habitat for endangered or rare species. The Project will not cause substantial environmental damage or impact wildlife.

- 4. The design of the subdivision or type of improvements is not likely to cause serious public health or safety problems.**

**Facts to Support This Finding:** The Project is to subdivide the airspace of the proposed multi-family development. The Project will comply with all applicable Building and Fire Codes to ensure public health and safety. The proposed density will comply with the allowed density by the R-3 Zone and the City's existing infrastructure will adequately serve the Project. Therefore, the Project will not cause any public health or safety problems.

- 5. The design of the subdivision or the type of improvements will not conflict with easements acquired by the public at large for access through or use of, property within the proposed subdivision (This finding shall apply only to easements of record or to easements established by judgement of a court of competent jurisdiction and no authority is hereby granted to a legislative body to determine that the public at large has acquired easements for access through or use of property within the proposed subdivision).**

**Facts to Support This Finding:** The proposed design of the subdivision does not conflict with easements acquired by the public at large for access through or use of property within the proposed subdivision. There are no known easements on the subject property. Therefore, the Project will not conflict with any such easements.

- 6. The discharge of sewage from the proposed subdivision into the community sewer system will not result in violation of existing requirements specified by the California Regional Water Quality Control Board.**

**Facts to Support This Finding:** The Arcadia Public Works Services Department has determined that the City's existing infrastructure can adequately serve the Project. The discharge of sewage from the Project into the community sewer system will comply with all requirements specified by the California Regional Water Quality Control Board.

**7. The proposed subdivision, its design, density, and type of development and improvements conform to the regulation of the Development Code and the regulations of any public agency having jurisdiction by law.**

**Facts to Support This Finding:** The approved development and the proposed subdivision of the airspace for the multi-family development is in conformance with the City's Development Code, as all development standards are being met, and all of the improvements required for the site would comply with the regulations in the City's Development Code and requirements of any public agency having jurisdiction by law.

Removal of a Healthy Protected Tree

**8. The removal of the trees is necessary.**

**Facts to Support This Finding:** The Project will require the removal of 11 protected trees on site, which include 10 Coast Live Oak trees and one California Sycamore tree. The removal of these protected trees is necessary as they are located at the center of the site and within the footprint of the proposed building foundations and driveway areas. Additionally, five of the oak trees exhibit unbalanced canopies, and one Sycamore tree is in poor health.

A Certified Arborist evaluated the potential to retain the trees on site; however, due to the proximity to proposed building foundations, it was determined that the protected trees would not have sufficient space to support healthy growth if preserved. Therefore, the Arborist has recommended their removal.

**9. The removal of the trees is more desirable than alternative project designs.**

**Facts to Support This Finding:** The location of many of the protected trees near the center of the site limits the feasibility of alternative project designs that would avoid their removal. The trees are distributed throughout the central portion of the site, leaving limited access to the interior of the lot, while only the rear portion remains free of protected trees.

Additionally, because most of the protected trees are Coast Live Oak trees, they require substantial protection areas to accommodate root and canopy growth. These protection requirements would significantly reduce the buildable area of the site and may restrict development to projects that only meet the minimum allowable density.

#### **10. Mitigation measures will be applied for the removal of the trees.**

**Facts to Support This Finding:** The Certified Arborist who reviewed the protected trees on site has recommended that the Appellant plant a minimum of 13, 24-inch box Coast Live Oak trees and four (4), 24-inch box California Sycamore trees for the removal of the protected trees.

The site can accommodate up to four Coast Live Oak trees within the front yard of the site, providing sufficient space for their root and canopy extension, and seven additional Coast Live Oak trees will be planted along the central walkway in between buildings. Four (4) California Sycamore trees will be planted along the westerly property line. Additionally, the Certified Arborist recommended installing root barriers along the driveways, walkways, and building foundations to prevent potential root damage from the growth of the replacement trees. Based on these measures, the removal of the healthy protected trees is warranted to accommodate the proposed development.

### **ENVIRONMENTAL ANALYSIS**

It has been determined that the Project site is less than five (5) acres; the Project site has no value as a habitat for endangered, rare or threatened species; the proposed Project will not have any significant effects upon the environment, and the site can be adequately served by all the required utilities and public services. Therefore, the Map is exempt under Class 32 (In-Fill Development Projects) pursuant to Section

15332 of the State California Environmental Quality Act (CEQA) Guidelines - refer to Attachment No. 11 for the Preliminary Exemption Assessment.

### **PUBLIC COMMENTS/NOTICE**

A public hearing notice for this item was posted at the City Clerk's Office, City Council Chambers, at the Arcadia Library, and the City's website, and was mailed to property owners within 300 feet of the subject property on June 4, 2026. As of June 11, 2026, no comments have been received.

### **FISCAL IMPACT**

The net long-term fiscal impact would depend on final assessed valuations, the City's share of property tax revenues, utility user tax, and the cost of providing municipal services to the site. As a privately owned residential development, the future condominium owners will pay property taxes and utility user taxes. One-time revenues will also be collected through building permit and plan check fees, impact fees, and sewer and water connection charges during construction.

Property tax revenues would be based on the assessed value of each unit at the time of sale, and while the City receives only a portion of the 1% ad valorem property tax, the aggregate assessed valuation of 30 ownership units instead of the existing tax from the two units currently on site would represent a fairly substantial new taxable base. These revenues would be proportionally offset by the increased demand for City services, which would involve all City departments.

In addition, the Project would generate one-time revenues during construction, including building permit and plan check fees, development impact fees, and sewer and water connection charges. These revenues would not provide ongoing General Fund support but would help recover the City's costs associated with plan review, permitting, and infrastructure capacity.

### **RECOMMENDATION**

It is recommended that the City Council adopt Resolution No. 7699, find the Project is Categorically Exempt from the California Environmental Quality Act ("CEQA") pursuant to Section 15332 of the CEQA Guidelines as a Class 32 (Infill) exemption,

and approve Multi-Family SB 330 Application No. SB 330 25-01, Tentative Tract Map No. TTM 26-01 (84910), and Protected Healthy Tree Removal Permit No. TRH 26-02, subject to the proposed Conditions of Approval listed below.

### Planning

1. The Project shall be developed and maintained by the Property Owner/Applicant in a manner that is consistent with the plans submitted and conditionally approved for Multi-Family SB 330 Application No. SB 330 25-01, Tentative Tract Map No. TTM 26-01 (84910), and Protected Healthy Tree Removal Permit No. TRH 26-02, subject to the satisfaction of the Development Services Director or designee.
2. Prior to final inspection, a minimum of 13 - 24-inch box Coast Live Oak trees and four (4) 24-inch box California Sycamore trees shall be planted on the subject site as replacement trees. A Landscape Plan in compliance with the City's Water Efficient Landscape Ordinance shall be prepared and provided with the building plan-check submittal. Said replacement trees must be shown on the Landscape Plan and are subject to review and approval by the Planning Division. A follow-up report by a Certified Arborist confirming the replacement trees have been planted shall be submitted to the City prior to issuance of a Certificate of Occupancy.
3. Any required mechanical equipment, such as backflow devices and transformers, visible from the public right-of-way shall be screened from public view. Screening may include landscaping, solid walls or other methods deemed appropriate for the development.

### Building

4. The plans that are submitted to Building Services for plan-check shall comply with the latest adopted edition of the following codes as applicable:
  - a. California Building Code (CBC)
  - b. California Electrical Code
  - c. California Mechanical Code
  - d. California Plumbing Code
  - e. California Energy Code
  - f. California Fire Code
  - g. California Green Building Standards Code

- h. California Existing Building Code
  - i. Arcadia Municipal Code
- 5. Grading plans shall be submitted with the building plan check submittal, and are to be approved by Engineering, Planning and Building Services prior to the issuance of building permits. The grading plans shall indicate all site improvements and shall indicate complete drainage paths of all drainage water run-off.
- 6. A demolition permit shall be obtained from Building Services prior to the removal and/or demolition of the structures on site.

#### Engineering

- 7. The Property Owner/Applicant shall be responsible for the repair of all damage to public improvements in the public right-of-way resulting from construction related activities, including, but not limited to, the movement and/or delivery of equipment, materials, and soils to and/or from the site. The need for such repairs shall be determined by the Development Services Director, the Public Works Services Director, City Engineer, or their designees, during construction and up until issuance of a Certificate of Occupancy.
- 8. The proposed development will be required to adhere to Los Angeles County Low Impact Development (LID) requirements. All LID measures must be implementable within the property. A LID plan, showing the selected measures, shall be provided along with the grading and drainage plan. A Master Covenant for the LID and Maintenance Plan shall be recorded with the Los Angeles County Recorder prior to occupancy.
- 9. A hydrology report and a soils/geotechnical report shall be submitted with the plan check submittal to Building Services.
- 10. Prior to recordation of the final tract map, the Property Owner/Applicant shall complete the construction of or execute and provide a Subdivision Map Agreement and bond to the City for the following off-site improvements:
  - a. Remove the existing driveway approaches and construct new driveway approaches per the City Standard. Ensure Americans with Disabilities Act (ADA) access is provided around all driveway approaches within City right-of-way and development property lines. Improvements shall not encroach into neighboring properties/frontages.

- b. Remove the existing sidewalk and construct a new sidewalk per City Standard, providing adequate path of travel in compliance with ADA. Ensure locations around obstructions provide necessary clearances.
11. Prior to issuance of a Certificate of Occupancy, the Property Owner/Applicant shall repair any damage caused by the development to the asphalt street frontages, from property line to property line, including but not limited to, trench cuts and construction traffic, per the direction of the City Engineer.

#### Fire Department

12. All structures shall be provided with an automatic fire sprinkler system per the City of Arcadia Fire Department's Single & Multi-Family Dwelling Sprinkler Standard.

#### Public Works

13. The Property Owner/Applicant shall utilize the existing sewer lateral(s) if possible. If any drainage fixture elevation is lower than the elevation of the next upstream manhole cover, an approved backwater valve will be required.
14. In order to verify the required water service size for the Project, the Property Owner/Applicant shall submit to the Public Works Services Department calculations for the maximum domestic use demand and maximum fire demand, prior to the issuance of a building permit. Fire protection requirements shall be as stipulated by the Arcadia Fire Department and shall conform to the Arcadia Standard Plan.
15. Prior to the issuance of a building permit, the Property Owner/Applicant shall submit a Water Meter Permit Application to the Public Works Services Department.
16. The Property Owner/Applicant shall provide a new water service installation. Installation shall be according to the specifications of the Public Works Services Department, Engineering Division. Abandonment of existing water services, if necessary, shall be completed by the Property Owner/Applicant, according to Public Works Services Department, Engineering Section specifications.
17. The Applicant/Property Owner shall comply with the General Construction National Pollutant Discharge Elimination System (NPDES) Permit, submit a Notice of Intent (NOI) and pay applicable fees to the State Water Resources Control Board, and prepare a Storm Water Pollution Prevention Plan (SWPPP).

## General

18. The Property Owner/Applicant shall comply with all City requirements regarding building safety, fire prevention, detection, suppression, emergency access, public right-of-way improvements, parking, water supply and water facilities, sewer facilities, trash reduction and recycling requirements, and National Pollutant Discharge Elimination System (NPDES) measures, all to the satisfaction of the Building Official, Fire Marshal, Public Works Services Director, and Deputy Development Services Director. Compliance with these requirements is to be determined by having fully detailed construction plans submitted for plan check review and approval by the foregoing City officials and employees.
19. To the maximum extent permitted by law, Applicant must defend, indemnify, and hold the City, any departments, agencies, divisions, boards, and/or commissions of the City, and its elected officials, officers, contractors serving as City officials, agents, employees, and attorneys of the City ("Indemnitees") harmless from liability for damages and/or claims, actions, or proceedings for damages for personal injuries, including death, and claims for property damage, and with respect to all other actions and liabilities for damages caused or alleged to have been caused by reason of the Applicant's activities in connection with SB 330 25-01, TTM 26-01, and TRH 26-02 ("Project") on the Project site, and which may arise from the direct or indirect operations of the Applicant or those of the Applicant's contractors, agents, tenants, employees or any other persons acting on Applicant's behalf, which relate to the development and/or construction of the Project. This indemnity provision applies to all damages and claims, actions, or proceedings for damages, as described above, regardless of whether the City prepared, supplied, or approved the plans, specifications, or other documents for the Project.

In the event of any legal action challenging the validity, applicability, or interpretation of any provision of this approval, or any other supporting document relating to the Project, the City will notify the Applicant of the claim, action, or proceedings and will cooperate in the defense of the matter. The Applicant must indemnify, defend and hold harmless the Indemnitees, and each of them, with respect to all liability, costs and expenses incurred by, and/or awarded against, the City or any of the Indemnitees in relation to such action. Within 15 days' notice from the City of any such action, the Applicant shall provide to the City a cash deposit to cover legal fees, costs, and expenses incurred by City in connection with defense of any legal action in an initial

amount to be reasonably determined by the City Attorney. The City may draw funds from the deposit for such fees, costs, and expenses. Within 5 business days of each and every notice from the City that the deposit has fallen below the initial amount, Applicant/Property Owner shall replenish the deposit each and every time in order for City's legal team to continue working on the matter. The City shall only refund to the Applicant/Property Owner any unexpended funds from the deposit within 30 days of: (i) a final, non-appealable decision by a court of competent jurisdiction resolving the legal action; or (ii) full and complete settlement of legal action. The City shall have the right to select legal counsel of its choice. The parties hereby agree to cooperate in defending such action. The City will not voluntarily assist in any such third-party challenge(s). In consideration for approval of the Project, this condition shall remain in effect if the entitlement(s) related to this Project is rescinded or revoked, at the request of the Applicant or not.

20. Approval of Multi-Family SB 330 Application No. SB 330 25-01, Tentative Tract Map No. TTM 26-01 (84910), and Protected Healthy Tree Removal Permit No. TRH 26-02 shall not be in effect unless the Property Owner and Applicant have executed and filed the Acceptance Form with the City on or before 30 calendar days after the City Council has adopted Resolution No. 7699. The Acceptance Form to the Development Services Department is to indicate awareness and acceptance of the conditions of approval.

Approved:



Dominic Lazzaretto  
City Manager

Attachment No. 1: Resolution No. 7699

Attachment No. 2: Aerial Photo with Zoning Information and Photos of the Subject Property and Vicinity

Attachment No. 3: Appeal Letter, dated May 15, 2026

Attachment No. 4: Letter from the City Manager, dated May 7, 2026

Attachment No. 5: PC Resolution No. 2187 and Planning Commission Minutes dated April 28, 2026, and May 12, 2026, and Planning Commission Staff Reports dated April 28, 2026 and May 12, 2026, without attachments

Attachment No. 6: Public Comments

Attachment No. 7: Architectural Plans

Attachment No. 8: Tentative Tract Map

Attachment No. 9: Arborist Report, dated March 25, 2026

Attachment No.10: Preliminary Exemption Assessment

# Attachment No. 1

Resolution No. 7699

RESOLUTION NO. 7699

A RESOLUTION OF THE CITY COUNCIL OF THE CITY OF ARCADIA, CALIFORNIA, APPROVING APPEAL NO. 26-01 AND OVERTURNING THE PLANNING COMMISSION'S DENIAL OF MULTI-FAMILY SB 330 APPLICATION NO. SB 330 25-01, TENTATIVE TRACT MAP NO. TTM 26-01 (84910), AND PROTECTED HEALTHY TREE REMOVAL NO. TRH 26-02 WITH A CATEGORICAL EXEMPTION UNDER THE CALIFORNIA ENVIRONMENTAL QUALITY ACT (CEQA) FOR A NEW 30 UNIT, MULTI-FAMILY RESIDENTIAL CONDOMINIUM DEVELOPMENT LOCATED AT 514 FAIRVIEW AVENUE

WHEREAS, on October 21, 2025, January 2, 2026, and February 13, 2026, applications for Multi-Family SB 330 Application No. SB 330 25-01, Tentative Tract Map No. TTM 26-01 (84910), and Protected Healthy Tree Removal Permit No. TRH 26-02 were filed, respectively, by Eric Tsang on behalf of the property owner, 518 Fairview LLC, for a new 30 unit, contemporary style, multi-family residential condominium development and the removal of 11 protected trees at 514 Fairview Avenue (collectively, "Project"); and

WHEREAS, on March 5, 2026, Planning Services completed an environmental assessment for the Project in accordance with the California Environmental Quality Act ("CEQA") and recommends that the City Council determine that the Project qualifies as a Class 32 Categorical Exemption under CEQA pursuant to Section 15332 of the CEQA Guidelines because the Project is considered an in-fill development project; and

WHEREAS, on April 28, 2026, a duly noticed public hearing was held before the Planning Commission on said Project, at which time all interested persons were given full opportunity to be heard and to present evidence. At this hearing, the Planning Commission found the Project to not be compatible with the adjacent neighborhood in terms of the massing and voted 4-1, with Commission Wilander dissenting, to deny the Project and directed Staff to return with a revised resolution at the next Planning Commission meeting; and

WHEREAS, on May 12, 2026, a revised resolution was presented to the Planning Commission for consideration and the Planning Commission voted 3-2, with Commissioners Wilander and Hui dissenting, to adopt Planning Commission Resolution No. 2187 denying the Project; and

WHEREAS, on May 15, 2026, within the 10-day appeal period, the Planning Commission's denial of the Project was appealed by the Applicant; and

WHEREAS, on June 16, 2026, a duly noticed public hearing was held by the City Council, to consider the appeal, at which time all interested persons were given full opportunity to be heard and to present evidence; and

NOW, THEREFORE, THE CITY COUNCIL OF THE CITY OF ARCADIA, CALIFORNIA, HEREBY RESOLVES AS FOLLOWS:

SECTION 1. The factual data submitted by the Development Services Department in the staff report dated June 16, 2026, are true and correct.

SECTION 2. This City Council finds that based upon the entire record, pursuant to Sections 9105.03.060(A) and 9107.19.050(F) of the Development Code, all of the following findings can be made:

Tentative Tract Map

1. The proposed map, subdivision design, and improvements are consistent with the General Plan, any applicable specific plan, and the Subdivisions Division of the Development Code:

FACT: The Project is in compliance with all of the provisions of the City's General Plan, Subdivisions Division of the Development Code, and the State Subdivision Map Act. It has been determined that the proposed subdivision is consistent with the General Plan High Density Residential Land Use designation and the R-3, High Density Multiple Family Residential zoning designation. These designations are intended to accommodate high density, attached or detached residential units such as condominiums, within the appropriate neighborhoods. The proposed Tentative Parcel Map complies with the Subdivision Map Act regulations, and there is no specific plan applicable to this Map. The site is physically suitable for the approved condominium project. The Map would not adversely affect the

comprehensive General Plan and is consistent with the following General Plan goals and policy:

Land Use and Community Design Element

- Policy LU-1.1: Promote new infill and redevelopment projects that are consistent with the City's land use and compatible with surrounding existing uses.
- Policy H-2.3: Encourage compatible residential development in areas on underutilized land.
- Policy H-2.4: Maintain development standards, regulations, and design features that are flexible to provide a variety of housing types and facilitate housing that is appropriate for the neighborhoods in which they are located.
- Policy H-4.4: Support infill development at appropriate locations in the City.

2. The site is physically suitable for the type and proposed density of development:

FACT: The R-3 Zone requires a minimum density of one dwelling unit per 2,200 square feet of lot area, and a maximum density of one unit per 1,450 square feet of lot area. Based on the lot area of 57,795 square feet, a minimum of 26 units and a maximum of 39 units could be developed at this site. Therefore, the proposed

30 unit development complies with the density requirements of the underlying zone, as well as all other applicable zoning requirements including but not limited to parking, setbacks, height, and open space. Therefore, the site is physically suitable for the Project.

3. The design of the subdivision and the proposed improvements are not likely to cause substantial environmental damage or substantially and avoidably injure fish or wildlife or their habitat:

FACT: The Project is a subdivision of an infill site within an urbanized area and does not serve as a habitat for endangered or rare species. The Project will not cause substantial environmental damage or impact wildlife.

4. The design of the subdivision or type of improvements is not likely to cause serious public health or safety problems:

FACT: The Project is to subdivide the airspace of the proposed multi-family development. The Project will be in compliance with all applicable Building and Fire Codes to ensure public health and safety. The proposed density will comply with the allowed density by the R-3 Zone and the City's existing infrastructure will adequately serve the Project. Therefore, the Project will not cause any public health or safety problems.

5. The design of the subdivision or the type of improvements will not conflict with easements acquired by the public at large for access through or use of, property within the proposed subdivision (This finding shall apply only to easements of record or to easements established by judgment of a court of competent jurisdiction and no authority is hereby granted to a legislative body to determine that the public at large has acquired easements for access through or use of property within the proposed subdivision):

FACT: The proposed design of the subdivision does not conflict with easements acquired by the public at large for access through or use of property within the proposed subdivision. There are no known easements on the subject property. Therefore, the Project will not conflict with any such easements.

6. The discharge of sewage from the proposed subdivision into the community sewer system will not result in violation of existing requirements specified by the California Regional Water Quality Control Board:

FACT: The Arcadia Public Works Services Department determined that the City's existing infrastructure will adequately serve the Project. The discharge of sewage from the Project into the community sewer system will not result in violation of existing requirements specified by the California Regional Water Quality Control Board.

7. The proposed subdivision, its design, density, and type of development and improvements conforms to the regulation of the Development Code and the regulations of any public agency having jurisdiction by law:

FACT: The approved development and the proposed subdivision of the airspace for the multi-family development is in conformance with the City's Development Code, as all development standards are being met, and all of the improvements required for the site would comply with the regulations in the City's Development Code and requirements of any public agency having jurisdiction by law.

#### **Removal of a Healthy Protected Tree**

8. The removal of the trees is necessary:

FACT: The Project will require the removal of 11 protected trees on site, which include 10 Coast Live Oak trees and one California Sycamore tree. The removal of these protected trees is necessary as they are located at the center of the site and within the footprint of the proposed building foundations and driveway areas. Additionally, five of the oak trees exhibit unbalanced canopies, and one Sycamore tree is in poor health.

A Certified Arborist evaluated the potential to retain the trees on site; however, due to the proximity to proposed building foundations, it was determined

that the protected trees would not have sufficient space to support healthy growth if preserved. Therefore, the Arborist has recommended their removal.

9. The removal of the trees is more desirable than alternative project designs:

FACT: The location of many of the protected trees near the center of the site limits the feasibility of alternative project designs that would avoid their removal. The trees are distributed throughout the central portion of the site, leaving limited access to the interior of the lot, while only the rear portion remains free of protected trees.

Additionally, because most of the protected trees are Coast Live Oak trees, they require substantial protection areas to accommodate root and canopy growth. These protection requirements would significantly reduce the buildable area of the site and may restrict development to projects that only meet the minimum allowable density.

10. Mitigation measures will be applied for the removal of the trees:

FACT: The Certified Arborist who reviewed the protected trees on site has recommended that the Applicant plant a minimum of 13 24-inch box Coast Live Oak trees and four (4) 24-inch box California Sycamore for the removal of the protected trees.

The site can accommodate up to four Coast Live Oak trees within the front yard of the site, providing sufficient space for their root and canopy extension and seven additional Coast Live Oak trees will be planted along the central walkway in between buildings. Four (4) California Sycamore trees will be planted along the westerly property line. Additionally, the Certified Arborist recommended installing root barriers along the driveways, walkways, and building foundations to prevent potential root damage from the growth of the replacement trees. Based on these measures, the removal of the healthy protected trees is warranted to accommodate the proposed development.

SECTION 3. Pursuant to the provisions of the California Environmental Quality Act ("CEQA"), it has been determined that the project site is less than five (5) acres; the project site has no value as a habitat for endangered, rare or threatened species; the proposed project will not have any significant effects upon the environment, and the site can be adequately served by all the required utilities and public services. Therefore, this Project is a Class 32 Categorical Exemption as an infill-development project per Section 15332 of the CEQA Guidelines.

SECTION 4. For the foregoing reasons the City Council determines that the Project is Categorically Exempt under the California Environmental Quality Act ("CEQA") Section 15332, Class 32, and approves Appeal No. 26-01 overturning the

Planning Commission's decision to deny Multi-Family SB 330 Application No. SB 330 25-01, Tentative Tract Map No. TTM 26-01 (84910), and Protected Healthy Tree Removal Permit No. TRH 26-02 for a new 30 unit, contemporary style, multi-family residential condominium development and the removal of 11 protected trees at 514 Fairview Avenue, subject to the conditions of approval attached hereto.

SECTION 5. The City Clerk shall certify to the adoption of this Resolution.

Passed, approved and adopted this 16<sup>th</sup> day of June, 2026.

\_\_\_\_\_

Paul P. Cheng  
Mayor of the City of Arcadia

ATTEST:

\_\_\_\_\_

City Clerk

APPROVED AS TO FORM:

  
\_\_\_\_\_

Michael J. Maurer  
City Attorney

Page Intentionally Left Blank

RESOLUTION NO. 2187

**Conditions of Approval**

Planning

1. The Project shall be developed and maintained by the Property Owner/Applicant in a manner that is consistent with the plans submitted and conditionally approved for Multi-Family SB 330 Application No. SB 330 25-01, Tentative Tract Map No. TTM 26-01 (84910), and Protected Healthy Tree Removal Permit No. TRH 26-02, subject to the satisfaction of the Development Services Director or designee.
2. Prior to final inspection, a minimum of 13 24-inch box Coast Live Oak trees and four (4) 24-inch box California Sycamore trees shall be planted on the subject site as replacement trees. A Landscape Plan in compliance with the City's Water Efficient Landscape Ordinance shall be prepared and provided with the building plan-check submittal. Said replacement trees must be shown on the Landscape Plan and are subject to review and approval by the Planning Division. A follow-up report by a Certified Arborist confirming the replacement trees have been planted shall be submitted to the City prior to issuance of a Certificate of Occupancy.
3. Any required mechanical equipment, such as backflow devices and transformers, visible from the public right-of-way shall be screened from public view. Screening may include landscaping, solid walls or other methods deemed appropriate for the development.

Building

4. The plans that are submitted to Building Services for plan-check shall comply with the latest adopted edition of the following codes as applicable:
  - a. California Building Code (CBC)
  - b. California Electrical Code
  - c. California Mechanical Code
  - d. California Plumbing Code
  - e. California Energy Code
  - f. California Fire Code
  - g. California Green Building Standards Code
  - h. California Existing Building Code
  - i. Arcadia Municipal Code
5. Grading plans shall be submitted with the building plan check submittal, and are to be approved by Engineering, Planning and Building Services prior to the issuance of building permits. The grading plans shall indicate all site improvements and shall indicate complete drainage paths of all drainage water run-off.

6. A demolition permit shall be obtained from Building Services prior to the removal and/or demolition of the structures on site.

#### Engineering

7. The Property Owner/Applicant shall be responsible for the repair of all damage to public improvements in the public right-of-way resulting from construction related activities, including, but not limited to, the movement and/or delivery of equipment, materials, and soils to and/or from the site. The need for such repair shall be determined by the Development Services Director, the Public Works Services Director, City Engineer, or their designees, during construction and up until issuance of a Certificate of Occupancy.
8. The proposed development will be required to adhere to Los Angeles County Low Impact Development (LID) requirements. All LID measures must be implementable within the property. A LID plan, showing the selected measures, shall be provided along with the grading and drainage plan. A Master Covenant for the LID and Maintenance Plan shall be recorded with the Los Angeles County Recorder prior to occupancy.
9. A hydrology report and a soils/geotechnical report shall be submitted with the plan check submittal to Building Services.
10. Prior to recordation of the final tract map, the Property Owner/Applicant shall complete the construction of or execute and provide a Subdivision Map Agreement and bond to the City for the following off-site improvements:
  - a. Remove the existing driveway approaches and construct new driveway approaches per the City Standard. Ensure Americans with Disabilities Act (ADA) access is provided around all driveway approaches within City right-of-way and development property lines. Improvements shall not encroach into neighboring properties/frontages.
  - b. Remove the existing sidewalk and construct a new sidewalk per City Standard providing adequate path of travel in compliance with ADA. Ensure locations around obstructions provide necessary clearances.
11. Prior to issuance of a certificate of occupancy, the Property Owner/Applicant shall repair any damages caused by the development to the asphalt street frontages from property line to property line including but not limited to trench cuts and construction traffic, per the direction of the City Engineer.

#### Fire Department

12. All structures shall be provided with an automatic fire sprinkler system per the City of Arcadia Fire Department's Single & Multi-Family Dwelling Sprinkler Standard.

#### Public Works

13. The Property Owner/Applicant shall utilize the existing sewer lateral(s) if possible. If any drainage fixture elevation is lower than the elevation of the next upstream manhole cover, an approved backwater valve will be required.
14. In order to verify the required water service size for the Project, the Property Owner/Applicant shall submit to the Public Works Services Department calculations for the maximum domestic use demand and maximum fire demand prior to the issuance of a building permit. Fire protection requirements shall be as stipulated by the Arcadia Fire Department and shall conform to the Arcadia Standard Plan.
15. Prior to the issuance of a building permit, the Property Owner/Applicant shall submit a Water Meter Permit Application to the Public Works Services Department.
16. The Property Owner/Applicant shall provide a new water service installation. Installation shall be according to the specifications of the Public Works Services Department, Engineering Division. Abandonment of existing water services, if necessary, shall be completed by the Property Owner/Applicant, according to Public Works Services Department, Engineering Section specifications.
17. The Applicant/Property Owner shall comply with the General Construction National Pollutant Discharge Elimination System (NPDES) Permit, submit a Notice of Intent (NOI) and pay applicable fees to the State Water Resources Control Board, and prepare a Storm Water Pollution Prevention Plan (SWPPP).

#### General

18. The Property Owner/Applicant shall comply with all City requirements regarding building safety, fire prevention, detection, suppression, emergency access, public right-of-way improvements, parking, water supply and water facilities, sewer facilities, trash reduction and recycling requirements, and National Pollutant Discharge Elimination System (NPDES) measures, all to the satisfaction of the Building Official, Fire Marshal, Public Works Services Director, and Deputy Development Services Director. Compliance with these requirements is to be determined by having fully detailed construction plans submitted for plan check review and approval by the foregoing City officials and employees.
19. To the maximum extent permitted by law, Applicant must defend, indemnify, and hold the City, any departments, agencies, divisions, boards, and/or commissions of the City, and its elected officials, officers, contractors serving as City officials, agents, employees, and attorneys of the City ("Indemnitees") harmless from liability for damages and/or claims, actions, or proceedings for damages for personal injuries, including death, and claims for property damage, and with respect to all other actions and liabilities for damages caused or alleged to have been caused by reason of the Applicant's activities in connection with SB 330 25-01, TTM 26-01, and TRH 26-02 ("Project") on the Project site, and which may arise from the direct or indirect operations of the Applicant or those of the Applicant's contractors, agents, tenants, employees or any other persons acting

on Applicant's behalf, which relate to the development and/or construction of the Project. This indemnity provision applies to all damages and claims, actions, or proceedings for damages, as described above, regardless of whether the City prepared, supplied, or approved the plans, specifications, or other documents for the Project.

In the event of any legal action challenging the validity, applicability, or interpretation of any provision of this approval, or any other supporting document relating to the Project, the City will notify the Applicant of the claim, action, or proceedings and will cooperate in the defense of the matter. The Applicant must indemnify, defend and hold harmless the Indemnitees, and each of them, with respect to all liability, costs and expenses incurred by, and/or awarded against, the City or any of the Indemnitees in relation to such action. Within 15 days' notice from the City of any such action, the Applicant shall provide to the City a cash deposit to cover legal fees, costs, and expenses incurred by City in connection with defense of any legal action in an initial amount to be reasonably determined by the City Attorney. The City may draw funds from the deposit for such fees, costs, and expenses. Within 5 business days of each and every notice from the City that the deposit has fallen below the initial amount, Applicant/Property Owner shall replenish the deposit each and every time in order for City's legal team to continue working on the matter. The City shall only refund to the Applicant/Property Owner any unexpended funds from the deposit within 30 days of: (i) a final, non-appealable decision by a court of competent jurisdiction resolving the legal action; or (ii) full and complete settlement of legal action. The City shall have the right to select legal counsel of its choice. The parties hereby agree to cooperate in defending such action. The City will not voluntarily assist in any such third-party challenge(s). In consideration for approval of the Project, this condition shall remain in effect if the entitlement(s) related to this Project is rescinded or revoked, at the request of the Applicant or not.

20. Approval of Multi-Family SB 330 Application No. SB 330 25-01, Tentative Tract Map No. TTM 26-01 (84910), and Protected Healthy Tree Removal Permit No. TRH 26-02 shall not be in effect unless the Property Owner and Applicant have executed and filed the Acceptance Form with the City on or before 30 calendar days after the City Council has adopted the Resolution. The Acceptance Form to the Development Services Department is to indicate awareness and acceptance of the conditions of approval.

---

# Attachment No. 2

Aerial Photo with Zoning Information and  
Photos of the Subject Property and Vicinity

Site Address: **514 FAIRVIEW AVE**

Property Owner(s): Property Owner

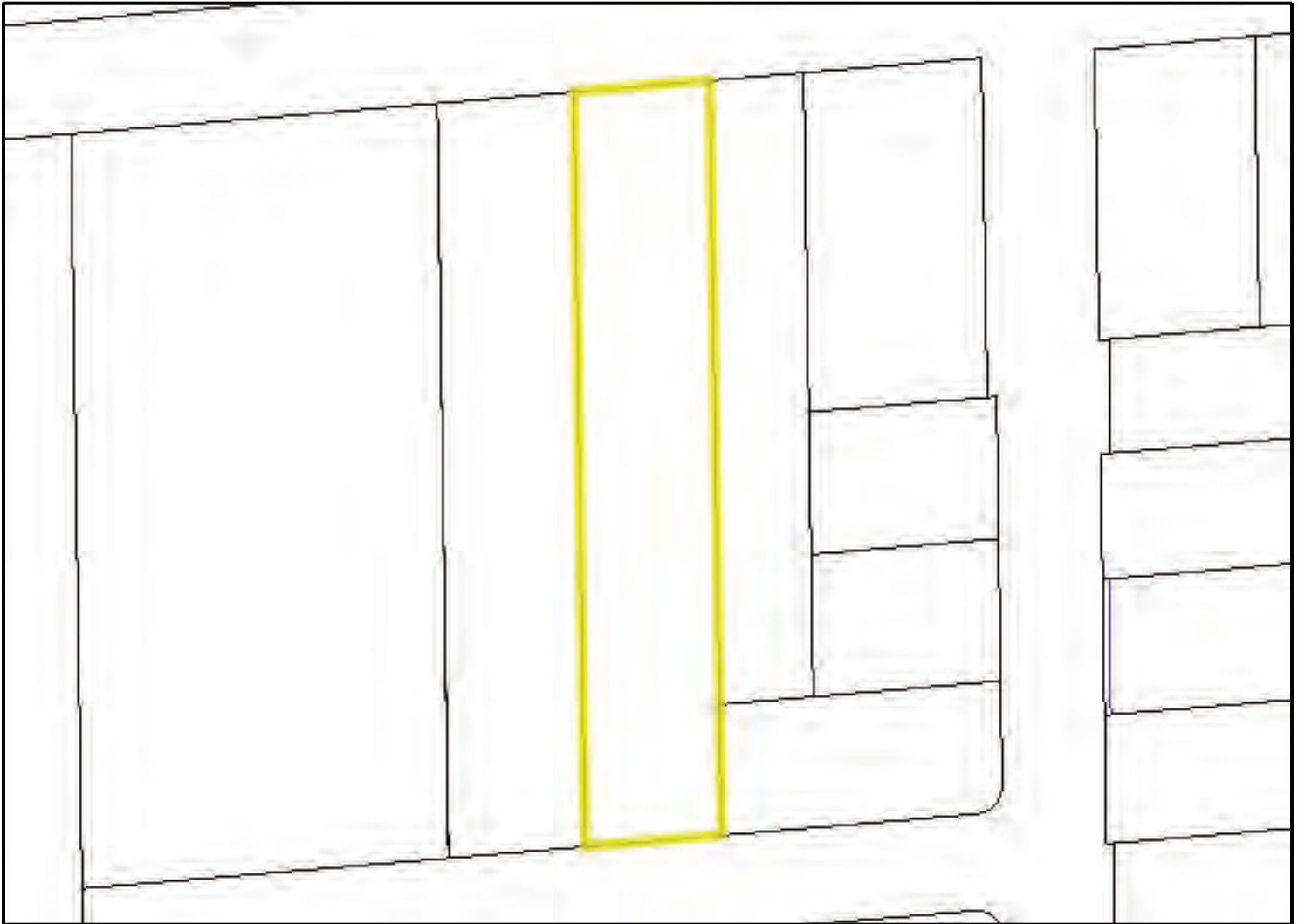

Property Characteristics	
<b>Zoning:</b>	R-3
<b>General Plan:</b>	HDR
<b>Lot Area (sq ft):</b>	
<b>Main Structure / Unit (sq. ft.):</b>	1,044
<b>Year Built:</b>	1927
<b>Number of Units:</b>	2
Overlays	
<b>Architectural Design Overlay:</b>	N/A
<b>Downtown Overlay:</b>	N/A
<b>Downtown Parking Overlay:</b>	N/A
<b>Parking Overlay:</b>	N/A
<b>Racetrack Event Overlay:</b>	N/A
<b>Residential Flex Overlay:</b>	N/A
<b>Special Height Overlay:</b>	N/A

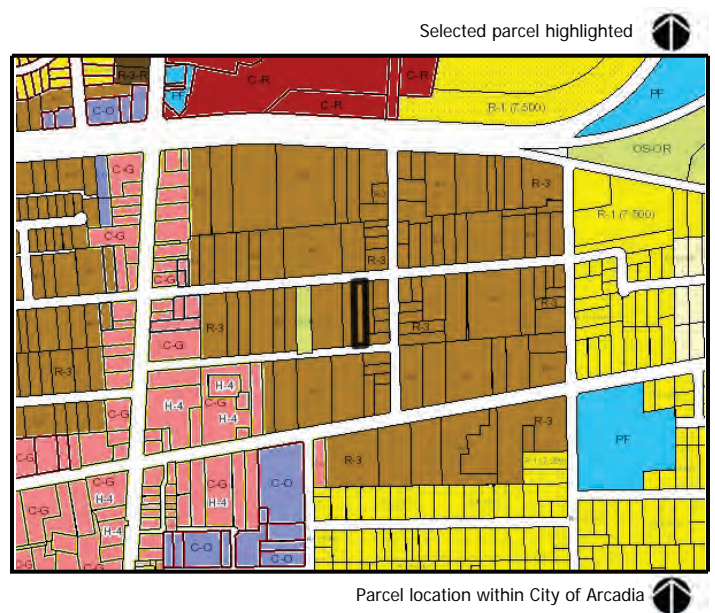

Site Address: **518 FAIRVIEW AVE**

Property Owner(s): Property Owner

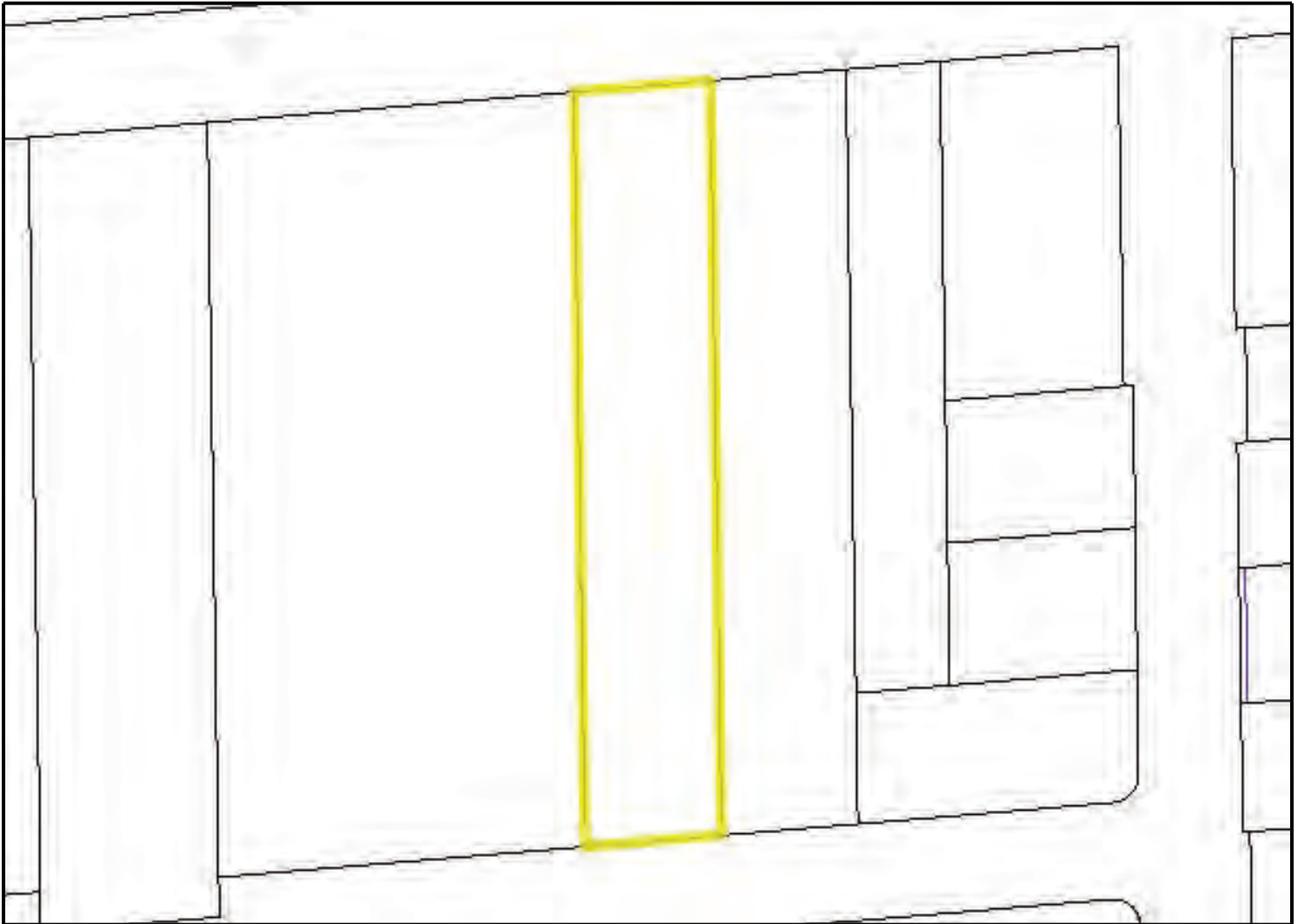

Property Characteristics	
<b>Zoning:</b>	R-3
<b>General Plan:</b>	HDR
<b>Lot Area (sq ft):</b>	
<b>Main Structure / Unit (sq. ft.):</b>	1,672
<b>Year Built:</b>	1927
<b>Number of Units:</b>	1
Overlays	
<b>Architectural Design Overlay:</b>	N/A
<b>Downtown Overlay:</b>	N/A
<b>Downtown Parking Overlay:</b>	N/A
<b>Parking Overlay:</b>	N/A
<b>Racetrack Event Overlay:</b>	N/A
<b>Residential Flex Overlay:</b>	N/A
<b>Special Height Overlay:</b>	N/A

Selected parcel highlighted



Parcel location within City of Arcadia

514-518 Fairview site photos







# Attachment No. 3

Appeal Letter, dated May 15, 2026

May 15, 2026

**Statement of Appeal of the City of Arcadia Planning Commission Decision to Deny a Multifamily Housing Development Project at 514 Fairview Avenue (Application Nos. SB 330 52-01, TTM 26-01 (84910), and TRH 26-02)**

Dear Mr. Arreola,

Please accept this letter as the formal Statement of Appeal regarding the Planning Commission’s May 12, 2026, decision to deny the above-referenced 30-unit multi-family residential project (the “Project”). We respectfully appeal the Planning Commission’s decision to the City Council on the grounds that the denial was an abuse of discretion, was not supported by the administrative record, and violates several state housing laws including the Housing Accountability Act (“HAA”), Permit Streamlining Act, and Housing Element Law.

Our appeal is based on the following issues:

**1. The Project Complies with the Objective Standards of the City of Arcadia Municipal Code (“AMC”).**

The HAA provides that a housing development project shall be deemed consistent with applicable local requirements “if there is substantial evidence that would allow a reasonable person to conclude that the housing development project” is consistent. (Gov. Code § 65589.5(f)(4).) The Project as proposed is consistent with all applicable local requirements. City staff repeatedly concluded the Project is in substantial conformance and City planning staff who are charged with carrying out the AMC constitute reasonable people. (April 28, 2026, Planning Commission Agenda Packet, pp. 12-22; May 12, 2026, Planning Commission Agenda Packet, p. 11.) A reasonable person would thus conclude that the Project as proposed complies with all applicable standards. Nonetheless, the Planning Commission impermissibly denied the Project based on subjective criteria. (May 12, 2026, Planning Commission Agenda Packet, p. 46.)

**2. The Project is Deemed Consistent as a Matter of Law Pursuant to the HAA.**

The HAA mandates that local agencies adhere to a strict timeline and procedure to determine whether a proposed housing development project is inconsistent with any applicable plan, program, policy, ordinance, standard, or other requirement. (Gov. Code § 65589.5(j)(2).) Within 30 days of the date that a housing application for 150 or fewer housing units is determined to be complete, local agencies must provide “written documentation identifying the provision or provisions, and an explanation of the reason or reasons it considers the housing development to be inconsistent, not in compliance” (*Id.* at (j)(2)(A)(i).) When a local agency fails to provide the required documentation within the specified timeline, the HAA provides that the housing development project “shall be deemed consistent, compliant, and in conformity with the applicable plan, program, policy, ordinance, standard, requirement, or other similar provision.” (*Id.* at (j)(2)(B).)

No written documentation was provided by the City identifying provisions and reasons the City considered the housing development to be inconsistent within 30 days of the date the application

was deemed complete. The application is therefore deemed consistent, compliant, and in conformity with all applicable requirements as a matter of law pursuant to the HAA.

### **3. Reliance on Subjective Criteria to Disapprove the Project was Unlawful.**

The HAA establishes vesting rights for applications submitted pursuant to Government Code Section 65941.1 (“SB 330” applications). Local agencies shall only subject SB 330 applications to the ordinances in effect at the time the preliminary application was submitted. (Gov. Code § 65956(o)(1).) The HAA limits local agencies to imposing only “objective, quantifiable, written development standards, conditions, and policies” which “shall be applied to facilitate and accommodate development at the density permitted on the site and proposed by the development.” (*Id.* at (f)(1).) Objective standards are defined as “criteria that involve no personal or subjective judgment by a public official and are uniformly verifiable by reference to an external and uniform benchmark or criterion available and knowable by both the development applicant or proponent and the public official before submittal.” (*Id.* at (f)(9).)

During the April 28 Planning Commission meeting, Assistant City Attorney Kellan Martz advised the Commission on the record that such subjective denials are not legally supported. (May 12, 2026, Planning Commission Agenda Packet, p. 43 [“[Martz] clarified that the project follows the Development Code and the reasons for opposition are subjective and not objective”]). Despite this warning, and in contradiction of findings made by City staff that the Project was compatible with all applicable objective standards, the Planning Commission impermissibly denied the project based on subjective opinions regarding neighborhood compatibility in violation of the HAA.

### **4. Discretionary Review of Objective Development Standards**

The City of Arcadia Multifamily Objective Development Standards entitle housing development applicants to streamlined, ministerial review, and projects are entitled to up to three waivers of objective development standards with provision of an explanation as to why the development standard is inapplicable or unachievable. (AMC § 9102.01.170(C)(2).) The AMC delegates ministerial review of waiver requests to the Director and the decision is not appealable. (*Id.*)

The applicant complied with the AMC and was entitled to the three requested waivers. The Project applicant was entitled ministerial approval of the requested three waivers from objective development standards and provided requisite explanations detailing why the waived standards were inapplicable or not achievable in the building design. The waivers were approved by Planning Director, and that approval was final and nonreviewable.

The Planning Commission has no authority to review requested waivers for an SB 330 Project. The only item under the Planning Commission’s review was the Tentative Map, which is undoubtedly consistent with the density permitted by the AMC.

Nonetheless, the Planning Commission denied the waivers and the entire Project based on this denial, infringing on the streamlined, ministerial process afforded to SB 330 projects by the AMC. (§ 9102.01.170(C)(2).)

## **5. Failure to Make Legally Required Findings for Denial**

Under the HAA, a legally compliant housing project can only be denied if the local agency makes written findings, supported by a preponderance of the evidence, that the project would cause a specific, unmitigable adverse impact on public health or safety. (Gov. Code § 65956(j)(1).) The term “specific, adverse impact” is defined as “a significant, quantifiable, direct, and unavoidable impact, based on objective, identified written public health or safety standards, policies, or conditions as they existed on the date the application was deemed complete.” (*Id.* at (j)(1)(A).)

The Planning Commission failed to identify or make written findings that the Project would cause any specific, adverse impacts on public health or safety, and the denial thus violates the HAA.

## **6. The Project is Deemed Approved by Operation of the Permit Streamlining Act**

The Permit Streamlining Act sets forth comprehensive project approval procedures and timelines. (et. Seq.) Where the reviewing agency has made a California Environmental Quality Act (“CEQA”) exemption determination pursuant to Division 13 Public Resources Code Division, the agency must approve or disapprove the project within sixty days from the date the determination was made. Failure to act on the project within the sixty-day time limit renders the Project application deemed approved. (Gov. Code § 65956(b).)

The City made a CEQA exemption determination for the Project on March 5, 2026. (April 28, 2026, Planning Commission Agenda Packet, p. 106.) The Project was not acted upon within sixty days, rendering the Project application approved as a matter of law. Moreover, this time limit prohibits the City Council from delaying action on the appeal by continuance or otherwise.

## **7. Denial of the Project Would Violated the No Net Loss Provision of Housing Element Law**

The Housing Element Law requires that when a local agency denies a housing development project, or otherwise takes action which causes a housing development to result in a lower density than set forth in the City’s Housing Element, the local agency must concurrently upzone elsewhere to result in no net loss of housing opportunity. (Gov. Code § 65863(a)-(c).)

The Project site is identified in the City’s 6<sup>th</sup> Cycle Housing Element Site Inventory as a site suitable for residential development. The Planning Commission thus violated the No Net Loss provision of Housing Element Law when it denied the Project without concurrently upzoning residential sites elsewhere. Additionally, because the Project site is also a recycled housing inventory site in the City’s 4<sup>th</sup> and 5<sup>th</sup> Cycle Housing Elements, the City’s application of non-ministerial review procedures may constitute violation of Assembly Bill 1397. Any action that is taken that is inconsistent with an adopted housing element may lead to the California Housing and Community Development Department (HCD) revoking its findings that the City is in compliance with the Housing Element Law, exposing the City to the builder’s remedy and a loss of funding. (Gov. Code § 65585(i)(1).)



# Attachment No. 4

Letter from the City Manager,  
dated May 7, 2026



**Dominic Lazzaretto**

City Manager  
240 W Huntington Dr, Arcadia, CA 91007  
(626) 574-5401

---

May 7, 2026

Dear Planning Commissioners:

At the April 28, 2026, Planning Commission meeting, the Commission considered a proposed 30-unit multi-family residential condominium development at 514 Fairview Avenue. The project includes several entitlements, including a preliminary SB 330 application, and staff recommended approval.

Following discussion, the Planning Commission voted 4-1 to deny the project, citing concerns that its massing was not compatible with surrounding neighborhood development. As noted during the meeting by the Development Services Director and the Assistant City Attorney, this proposed action raises significant concerns regarding compliance with State housing law.

The Housing Accountability Act (HAA) limits a local agency's ability to deny or reduce the density of a housing development that complies with applicable, objective standards. A denial may only be supported if there is a preponderance of evidence in the record demonstrating that the project would result in a specific, adverse impact on public health or safety, and that there is no feasible method to mitigate or avoid that impact other than denial or approval at a lower density.

While broader policy discussions regarding development standards are appropriate, they must not influence decisions on individual projects that comply with objective standards. Denial on subjective grounds - such as perceived scale or neighborhood character - is **not** supported under State law for SB 330 projects and exposes the City to significant legal risk, including financial impacts to the City and taxpayers.

Serving on the Planning Commission carries the responsibility of making decisions grounded in the law and supported by the record, even when those decisions may be difficult or unpopular. We understand that this can be a challenging and sometimes difficult position

for Commissioners. Nonetheless, upholding these obligations is essential to ensuring fair, consistent, and legally defensible outcomes. As public officials, we have a duty to rule based on the law as it exists, not as we wish it to be.

A revised Resolution reflecting the denial will be presented to the Planning Commission for consideration at the May 12 meeting, per your direction at the past meeting. However, we are also including in the agenda packet the original approval version of the Resolution. At that time, the Commission will have the opportunity to reconsider its prior action in light of the applicable legal standards and the administrative record. If the Commission wishes to adopt a resolution for denial, it will need to identify specific health and safety reasons for the denial and include objective and quantifiable facts that support those findings. If it cannot make such findings, then approval would be warranted.

I am available to speak with any of you individually if you would like to discuss this further. Feel free to reach out to me by email at [domlazz@arcadiaca.gov](mailto:domlazz@arcadiaca.gov) or by phone at (626) 574-5401. I would also make the City Attorney's office available to you to explore these issues further, if needed.

Sincerely,



---

Dominic Lazzaretto  
City Manager

CC: City Council, City Attorney

# Attachment No. 5

PC Resolution No. 2187 and Planning Commission Minutes dated April 28, 2026, and May 12, 2026, and Planning Commission Staff Reports dated April 28, 2026 and May 12, 2026, without attachments

RESOLUTION NO. 2187

A RESOLUTION OF THE PLANNING COMMISSION OF THE CITY OF ARCADIA, CALIFORNIA, DENYING MULTI-FAMILY SB 330 APPLICATION NO. SB 330 25-01, TENTATIVE TRACT MAP NO. TTM 26-01 (84910), AND PROTECTED HEALTHY TREE REMOVAL PERMIT NO. TRH 26-02 FOR A NEW 30 UNIT, MULTI-FAMILY RESIDENTIAL CONDOMINIUM DEVELOPMENT LOCATED AT 514 FAIRVIEW AVENUE

WHEREAS, on October 21, 2025, January 2, 2026, and February 13, 2026, applications for Multi-Family SB 330 Application No. SB 330 25-01, Tentative Tract Map No. TTM 26-01 (84910), and Protected Healthy Tree Removal Permit No. TRH 26-02 were filed, respectively, by Eric Tsang on behalf of the property owner, 518 Fairview LLC, for a new 30 unit, contemporary style, multi-family residential condominium development and the removal of 12 protected trees at 514 Fairview Avenue (collectively, "Project"); and

WHEREAS, on April 28, 2026, a duly noticed public hearing was held before the Planning Commission on said Project, at which time all interested persons were given full opportunity to be heard and to present evidence. At this hearing, the Planning Commission determined the Project was out of character with the adjacent neighborhood in terms of massing and, therefore, the waiver for the massing requirement under the multifamily objective development standards is not granted. The Planning Commission voted 4-1 to deny the Project, and directed Staff to return with a revised resolution at the next Planning Commission meeting; and

WHEREAS, on May 12, 2026, a revised resolution was presented to the Planning Commission for consideration.

NOW, THEREFORE, THE PLANNING COMMISSION OF THE CITY OF ARCADIA, CALIFORNIA, HEREBY RESOLVES AS FOLLOWS:

SECTION 1. The factual data submitted by the Development Services Department in the staff report dated April 28, 2026, are true and correct.

SECTION 2. This Commission finds that based upon the entire record, pursuant to Sections 9105.03.060(A) and 9107.19.050(F) of the Development Code, all of the following findings cannot be made:

Tentative Tract Map

1. The proposed map, subdivision design, and improvements are consistent with the General Plan, any applicable specific plan, and the Subdivisions Division of the Development Code:

FACT: The Project is in compliance with all of the provisions of the City's General Plan, Subdivisions Division of the Development Code, and the State Subdivision Map Act. It has been determined that the proposed subdivision is consistent with the General Plan High Density Residential Land Use designation and the R-3, High Density Multiple Family Residential zoning designation. These designations are intended to accommodate high density, attached or detached

residential units such as condominiums, within the appropriate neighborhoods. The proposed Tentative Parcel Map complies with the Subdivision Map Act regulations, and there is no specific plan applicable to this Map. The site is physically suitable for the approved condominium project. The Map would not adversely affect the comprehensive General Plan and is consistent with the following General Plan goal and policy:

Land Use and Community Design Element

- Policy LU-1.1: Promote new infill and redevelopment projects that are consistent with the City's land use and compatible with surrounding existing uses.
- Policy H-2.3: Encourage compatible residential development in areas on underutilized land.
- Policy H-2.4: Maintain development standards, regulations, and design features that are flexible to provide a variety of housing types and facilitate housing that is appropriate for the neighborhoods in which they are located.
- Policy H-4.4: Support infill development at appropriate locations in the City.

2. The site is physically suitable for the type and proposed density of development:

FACT: The R-3 Zone requires a minimum density of one dwelling unit per 2,200 square feet of lot area, and a maximum density of one unit per 1,450 square feet of lot area. Based on the lot area of 57,795 square feet, a minimum of 26 units and a maximum of 39 units could be developed at this site. Therefore, the proposed 30 unit development complies with the density requirements of the underlying zone, as well as all other applicable zoning requirements including but not limited to parking, setbacks, height, and open space. Therefore, the site is physically suitable for the Project.

3. The design of the subdivision and the proposed improvements are not likely to cause substantial environmental damage or substantially and avoidably injure fish or wildlife or their habitat:

FACT: The Project is a subdivision of an infill site within an urbanized area and does not serve as a habitat for endangered or rare species. The Project will not cause substantial environmental damage or impact wildlife.

4. The design of the subdivision or type of improvements is not likely to cause serious public health or safety problems:

FACT: The Project is to subdivide the airspace of the proposed multi-family development. The Project will be in compliance with all applicable Building and Fire Codes to ensure public health and safety. The proposed density will comply with the

allowed density by the R-3 zone and the City's existing infrastructure will adequately serve the Project. Therefore, the Project will not cause any public health or safety problems.

5. The design of the subdivision or the type of improvements will not conflict with easements acquired by the public at large for access through or use of, property within the proposed subdivision (This finding shall apply only to easements of record or to easements established by judgment of a court of competent jurisdiction and no authority is hereby granted to a legislative body to determine that the public at large has acquired easements for access through or use of property within the proposed subdivision):

FACT: The proposed design of the subdivision does not conflict with easements acquired by the public at large for access through or use of property within the proposed subdivision. There are no known easements on the subject property. Therefore, the Project will not conflict with any such easements.

6. The discharge of sewage from the proposed subdivision into the community sewer system will not result in violation of existing requirements specified by the California Regional Water Quality Control Board:

FACT: The Arcadia Public Works Services Department determined that the City's existing infrastructure will adequately serve the Project. The discharge of

sewage from the Project into the community sewer system will not result in violation of existing requirements specified by the California Regional Water Quality Control Board.

7. The proposed subdivision, its design, density, and type of development and improvements conforms to the regulation of the Development Code and the regulations of any public agency having jurisdiction by law:

FACT: The Project is not in conformance with the City's Development Code. The Project is subject to the multifamily objective development standards established in Division 2 of the Development Code and shall comply with all objective development standards except for up to three standards which may be waived subject to the review of the Planning Commission. It has been determined that the Project is not compatible with the adjacent neighborhood in terms of massing due to many of the surrounding developments being two stories or two stories with semi-subterranean garages while the Project is three stories. Therefore, the objective development standard for massing is not granted and the Project is not in conformance with the regulations of the Development Code.

**Removal of a Healthy Protected Tree**

8. The removal of the trees is necessary:

FACT: The Project will require the removal of 12 protected trees on site which includes 11 Coast Live Oak trees and one California Sycamore tree. The removal of these protected trees is necessary as they are located at the center of the site and within the footprint of the proposed building foundations and driveway areas. Additionally, five of the oak trees exhibit unbalanced canopies, and one Sycamore tree is in poor health.

A Certified Arborist evaluated the potential to retain the trees on site; however, due to the proximity to proposed building foundations, it was determined that the protected trees would not have sufficient space to support healthy growth if preserved. Therefore, the Arborist has recommended their removal.

9. The removal of the trees is more desirable than alternative project designs:

FACT: The location of many of the protected trees near the center of the site limits the feasibility of alternative project designs that would avoid their removal. The trees are distributed throughout the central portion of the site, leaving limited access to the interior of the lot, while only the rear portion remains free of protected trees.

Additionally, because most of the protected trees are Coast Live Oak trees, they require substantial protection areas to accommodate root and canopy growth. These

protection requirements would significantly reduce the buildable area of the site and may restrict development to projects that only meet the minimum allowable density.

10. Mitigation measures will be applied for the removal of the trees:

FACT: The Certified Arborist who reviewed the protected trees on site has recommended that the Applicant plant a minimum of four (4) 36-inch box Coast Live Oak trees, five (5) 24-inch box Forest Pansy trees, and five (5) 24-inch box Crape Myrtle trees for the removal of the protected trees.

The site can only accommodate up to four Coast Live Oak trees within the front yard of the site, providing sufficient space for their root and canopy extension. Additionally, the Certified Arborist recommended installing root barriers along the driveways, walkways, and building foundations to prevent potential root damage from the growth of the replacement trees. Based on these measures, the removal of the healthy protected trees is warranted to accommodate the proposed development.

SECTION 3. For the foregoing reasons the Planning Commission finds that the Project is not in compliance with the findings of the Development Code and that the Project is incompatible with the neighborhood in terms of massing. Therefore, the Planning Commission denies Multi-Family SB 330 Application No. SB 330 25-01, Tentative Tract Map No. TTM 26-01 (84910), and Protected Healthy Tree Removal

Permit No. TRH 26-02 for a new 30 unit, contemporary style, multi-family residential condominium development and the removal of 12 protected trees at 514 Fairview Avenue.

SECTION 4. The Secretary shall certify to the adoption of this Resolution.

Passed, approved and adopted this 12th day of May, 2026.



Domenico Tallerico  
Chair, Planning Commission

ATTEST:



Lisa L. Flores  
Secretary

APPROVED AS TO FORM:



Michael J. Maurer  
City Attorney

STATE OF CALIFORNIA        )  
COUNTY OF LOS ANGELES   ) §:  
CITY OF ARCADIA            )

I, Lisa Flores, Secretary of the Planning Commission of the City of Arcadia, hereby certify that the foregoing Resolution No. 2187 was passed and adopted by the Planning Commission of the City of Arcadia, signed by the Chair, and attested to by the Secretary at a regular meeting of said Planning Commission held on the 12<sup>th</sup> day of May 2026, and that said Resolution was adopted by the following vote, to wit:

AYES:        Tallerico, Tsoi, and Arvizu

NOES:        Hui and Wilander

ABSENT:     None

  
\_\_\_\_\_  
Lisa L. Flores  
Secretary of the Planning Commission



**ARCADIA PLANNING COMMISSION  
REGULAR MEETING MINUTES  
TUESDAY, APRIL 28, 2026**

---

**CALL TO ORDER** Chair Tallerico called the meeting to order at 7:00 p.m.

**ROLL CALL**

PRESENT: Chair Tallerico, Vice Chair Tsoi, Commissioners Arvizu, Hui, and Wilander (arrived at 7:01 p.m.)

ABSENT: None

**SUPPLEMENTAL INFORMATION FROM STAFF REGARDING AGENDA ITEMS**

Development Services Director, Lisa Flores, reported that five (5) emails in opposition to Item No. 1 were received prior to the meeting and forwarded to the Commissioners. She further reported that revisions were made to both Resolutions, and redlined copies were provided.

**PUBLIC COMMENTS (5 minute time limit per person)**

There were none.

**PUBLIC HEARING**

1. **Resolution No. 2187** – Approving Multi-Family SB 330 Application No. SB 330 25-01, Tentative Tract Map No. TTM 26-01 (84910), and Protected Healthy Tree Removal Permit No. TRH 26-02 for a new 30 unit, multi-family residential condominium development located at 514 Fairview Avenue  
**CEQA:** Categorically Exempt  
**Recommendation:** Adopt

**Applicant:** Eric Tsang on behalf of 518 Fairview, LLC

**MOTION - PUBLIC HEARING**

Chair Tallerico introduced the item and Senior Planner, Edwin Arreola, presented the staff report.

Vice Chair Tsoi said since this is a through lot which street is considered the rear yard area.

Mr. Arreola stated it will be Arcadia Avenue since it has no access.

Vice Chair Tsoi asked whether the green open spaces on the plans are considered common or private spaces and what is the requirement for multi-family developments.

Mr. Arreola confirmed they are all common open spaces and it is 100 square feet per unit.

Commissioner Arvizu asked how many trees are required to replace the removal of one protected tree.

Mr. Arreola stated two trees are required to replace each removed protected tree unless deemed infeasible by a Certified Arborist.

Commissioner Arvizu asked if the replacement trees must be planted on the property.

Mr. Arreola confirmed yes.

Ms. Flores added that the requirement for replacement trees was one of the three waivers requested by the Applicant.

Commissioner Arvizu asked about the number of units proposed and if they are proposing density bonus.

Mr. Arreola clarified that they are not proposing density bonus and the project meets the minimum density per the Development Code.

Chair Tallerico asked what are the requirements for Senate Bill (SB) 330.

Mr. Arreola explained that any multi-family project of 2 or more units or any mixed-use project providing two thirds of residential, is subject to SB 330. He further explained that such projects are required to comply with a set of objective development standards set forth in the code. If they comply with the standards, they are entitled to no more than five (5) public hearings, and the design may be evaluated based on the objective standards. Therefore, the project cannot be denied if it complies with the objective development standards.

Chair Tallerico stated that SB 330 really limits the Planning Commission's to comment on design.

Ms. Flores confirmed that is correct and that the project is permitted by right.

Chair Tallerico asked how the height of the proposed project differs from those of neighboring developments.

Mr. Arreola stated that most buildings on Fairview Avenue are two stories, and there are a couple of developments that have semi subterranean garages.

Chair Tallerico asked if the development will appear taller than neighboring structures.

Mr. Arreola stated that the height of the proposed project complies with the Development Code, however, it will be slightly taller than the tallest buildings in the area, which are the developments with semi subterranean parking garages.

Chair Tallerico asked if there are any traffic concerns.

City Engineer Kevin Merrill stated that this project will not generate more traffic than is typical for multi-family developments and, therefore, does not raise any traffic-related concerns. He acknowledged residents' concerns regarding the intersection of La Cadena Avenue and Duarte Road and noted that the intersection was identified in 2016 as a location that may warrant a traffic signal. The intersection will be evaluated further as part of this project to determine whether it may meet the requirements for a traffic signal in the near future.

Chair Tallerico asked if traffic would be more noticeable because of the project.

Mr. Merrill said that given that each unit has a two-car garage the traffic in the area should not be impacted.

Commissioner Wilander asked if the Applicant used one of the waivers for the height of the buildings.

Mr. Arreola clarified that he did not because the height complies with the maximum height limit per the Development Code.

The public hearing was opened.

Eric Tsang, the project's architect and applicant, introduced himself and spoke on behalf of the property owner. He stated that they accept the conditions of approval and were available to answer any questions.

Commissioner Arvizu asked if hedges will be planted on both the west and east side of the property.

Mr. Tsang said yes and added that the hedges on the west side will be continuous along the property line while the hedges on the east will be broken up to allow back-up space for the garages of units no. 25 -30.

Vice Chair Tsoi asked how many waivers are being requested.

Mr. Tsang stated that they are requesting the three waivers permitted under the Development Code process, which they are entitled to, for replacement trees, building massing, and windows.

Vice Chair Tsoi asked for clarification about the waivers and why they are being granted if no low-income housing is being proposed.

Ms. Flores clarified that these waivers are for the objective development standards in the City's Development Code and not for density bonus.

Vice Chair Tsoi asked why they requested a waiver for the massing of the buildings.

Mr. Tsang explained that, because of the third-floor step-back, the stairways could not remain in that location because they would have to jog inward and relocating them elsewhere was not feasible due to the ground-floor garage.

Commissioner Arvizu asked if he could request the developer to donate trees to a City park to make up for the trees that will not be replaced at the project site.

Assistant City Attorney, Kellan Martz, clarified it could be a request but not a requirement. Ms. Flores added that if they agree, they must coordinate with the City's Public Works Department.

Commissioner Arvizu therefore asked the Applicant if the developer would be open to the suggestion to donate trees to a City park.

Mr. Tsang said he will discuss it with the developer.

Vice Chair Tsoi asked if the number of units feasible for a project is determined by the minimum or maximum density.

Mr. Martz stated that per SB 330 it is based on the project as presented so long as it complies with the Development Code.

Dr. Lorelee MacPike, a resident on Fairview Avenue, spoke in opposition to the project stating concerns with the height of the building, the coyotes that will be displaced from the vacant lot, and the proposed driveways of the development that will only have an entrance and exit on Fairview Avenue.

Susan Rogers, a resident on Fairview Avenue, spoke in opposition to the project specifically for the placement of the windows and the removal of the trees. She also cited concerns

about potential asbestos in the buildings that will be demolished and any exterior lights on the third floor that may shine through her windows.

Mr. Tsang addressed the concerns from the residents stating that a construction sign with the contractor's contact information will be posted on site for neighbors who wish to inquire about the project's construction timeline and any questions they may have. He also addressed privacy concerns and said they are willing to make the windows overlooking the adjacent properties opaque to mitigate potential privacy impacts.

Vice Chair Tsoi made a motion to close the public hearing.

Commissioner Arvizu seconded the motion.

Without objection, the motion was approved.

## **DISCUSSION**

Commissioner Wilander understood the public's concerns and said she shared some of the same concerns. She said however, it is clear the Commission is limited to reject the project and instead encouraged the public to write to their State officers about their objections to the laws that are limiting local governments. With that said, she was inclined to approve the project because it was an attractive design and an improvement from the existing conditions.

Vice Chair Tsoi said he disagreed with the design of the common open spaces because it is not big enough or functional for residents to use. Additionally, he is concerned that there are four (4) parking spaces facing Arcadia Avenue and that it is being treated as a rear yard setback. He said SB 330 was intended to streamline the review process to address the housing shortage and not a tool to maximize projects.

Mr. Martz reminded him that the project must be reviewed as presented and that no design changes could be suggested. Ms. Flores confirmed that the Development Code does not require common open space to include amenities. She also addressed Mr. Tsoi's concern regarding the visibility of the parking spaces along Arcadia Avenue, stating that they will not be visible from the street because they will be screened by a 6-foot wall.

Mr. Martz stated that objective standards are intended not only to streamline the review process, but also to inform applicants about the Development Code and what they can expect.

Vice Chair Tsoi disagreed, stating that he is basing his objections on the Development Code which is law.

Mr. Martz clarified that the project follows the Development Code and the reasons for opposition are subjective and not objective.

Vice Chair Tsoi stated that the proposed common open space does not fulfill the definition of common open space because it does not have any amenities or it is not functional for the residents.

Mr. Martz stated that the objective definition of common open space would be as it is defined in the Development Code and if amenities are not explicitly mentioned, they are not required to provide them.

Vice Chair Tsoi said that the proposed open spaces look like private areas, and he cannot tell the difference. He asked how common open spaces are defined.

Mr. Martz stated that open space according to the code shall be in the form of private or common open space via balconies, courtyards, at-grade patios, rooftop decks, gardens or terraces.

Vice Chair Tsoi said private and common space is different.

Mr. Martz clarified the code states it can be "either" private or common open space and 100 square feet per unit must be provided.

Commissioner Arvizu said he would not be in favor of approving a project like this under different circumstances. He addressed the public and stated that these laws are limiting local governments on what they are allowed to do.

Commissioner Arvizu referred to the public's concerns about the potential toxins within the old structures such as asbestos and lead and asked how the project is exempt from California Environmental Quality Act (CEQA) should they be found.

Ms. Flores explained that the project does not pose a threat to the environment and that, if asbestos were present, it would be contained within the building and properly abated. She stated that these issues would be addressed during the plan check process, during which the applicant would be required to submit a demolition plan and properly treat any hazardous materials identified prior to demolition of the buildings.

Commissioner Arvizu stated that the proposed building is not compatible with the neighborhood because of its massing and its height.

Commissioner Wilander asked Mr. Martz to speak about other cities or local governments who have challenged the State's requirements.

Mr. Martz said other cities have challenged the State's housing requirements and it has been difficult to win.

Chair Tallerico asked if SB 330 overrules CEQA.

Ms. Flores said that it does not overrule it, but it is exempt from its requirements.

Chair Tallerico said he had concerns about the windows on the third floor, the parking and potential impacts on traffic in the area. He also stated that he does not approve of the massing of the project and does not agree with granting the waiver for it.

Mr. Martz reminded the Commission that if the waivers are within reason, they must grant them.

Chair Tallerico asked if they must grant the three waivers.

Mr. Martz explained that they are entitled to three waivers according to the Development Code.

Chair Tallerico stated that he agreed to grant two of the waivers but not the third for massing and will not approve the project for that reason.

Vice Chair Tsoi agreed with the Chair.

Commissioner Arvizu asked if the next course of action following denial was for the Applicant to appeal the decision and then it would be heard by the City Council.

Mr. Kellan agreed that is the procedure but strongly discouraged the Commissioners from denying the project.

Commissioner Arvizu stated that he is in favor of denying the project and making the City Council aware of their concerns.

Mr. Martz recommended they do not deny it for those reasons because if City Council were to agree with that decision it would make the City vulnerable to a lawsuit. Moreover, they have not cited legitimate reason for denial, and their comments would be used against the City in court.

Chair Tallerico stated that he takes legal advice seriously, however, as an advisory board to the City Council he believes it is the Commission's responsibility to inform them about the residents' concerns as well as theirs.

Commissioner Hui commented on the limitations on her ability to disagree, noting that she must approve the project because it complies with the objective development standards required under SB 330.

Ms. Flores acknowledged their concerns regarding objective standards and stated that Staff shares similar concerns about various State laws. However, she noted that Staff is currently working on updating the objective development standards and plans to bring forward revised standards. She also encouraged the Commission to approve the project, noting that denial could place the City Council in a difficult position in the event of a challenge.

Commissioner Wilander asked if it would be possible to inform City Council about the project while still approving it.

Mr. Martz confirmed that is possible.

Commissioner Arvizu asked Mr. Martz what he thinks City Council would decide if an appeal for a denial was brought before them.

Mr. Martz stated that he cannot predict what they decide but hopes they will listen to their legal counsel.

Commissioner Arvizu said that this would only go to court if the City Council were to deny the project.

Mr. Martz said he should not count on what City Council will do. He also said he was concerned that the Commission had not articulated a reason for denial.

Vice Chair Tsoi stated his reasons for denial are that common open spaces and the rear yard setback along Arcadia Avenue do not meet the code setback.

Chair Tallerico asked if those reasons can be cited as health and safety concerns.

Vice Chair Tsoi disagreed however, he stood by the fact that the common open space was not functional.

## **MOTION**

It was moved by Commissioner Wilander to adopt Resolution No. 2187 approving Multi-Family SB 30 Application No. SB 330 25-01, Tentative Tract Map No. TTM 26-01 (84910), and Protected Healthy Tree Removal Permit No. TRH 26-02 for a new 30 unit, multi-family residential condominium development located at 514 Fairview Avenue in which the findings were made and is categorically exempt from CEQA.

No second was received and the motion failed.

It was moved by Commissioner Tallerico, seconded by Commissioner Arvizu to deny Resolution No. 2187 because project was not found to be compatible with the neighborhood, specifically the massing.

### **ROLL CALL**

AYES: Tallerico, Tsoi, Arvizu, and Hui  
NOES: Wilander  
ABSENT: None

The motion was approved.

### **PUBLIC HEARING**

1. **Resolution No. 2188** – Approving Planning Commission Administrative Modification No. PC AM 25-05 for an updated parking plan at the Arcadia Hub Shopping Center located at 1201 to 1325 S. Baldwin Avenue, and 733, 745, and 815 W. Naomi Avenue

**CEQA:** Categorically Exempt

**Recommendation:** Adopt

**Applicant:** Baldwin Arcadia Center, L.P.

### **MOTION - PUBLIC HEARING**

Chair Tallerico introduced the item and Planning Services Manager, Fiona Graham, presented the staff report.

Commissioner Hui asked if the parking plan would have to be done again if a new tenant was found for the former Burlington Coat Factory.

Ms. Graham stated that the property management has been looking for a tenant, but it has been a challenging space to fill, and it is difficult to project what the future tenant will be. She explained that they analyzed three different uses that could potentially occupy a portion of the space. If a tenant were to use the entire unit, they would analyze the parking requirements independently.

Commissioner Hui asked if the property could be used for housing.

Ms. Graham stated that is a possibility and if that were the case, a new parking study must be conducted.

Commissioner Arvizu asked if the property is zoned Mixed Use.

Ms. Graham stated that it is zoned General-Commercial, with a residential flex overlay.

The public hearing was opened.

Firas Aboulhosn introduced himself and said he represents the property owner. He informed the Commission that the property owner was considering their options, including redevelopment, and was open to suggestions from the public.

There were no other speakers for this item.

Commissioner Wilander made a motion to close the public hearing.

Chair Tallerico seconded the motion.

Without objection, the motion was approved.

## **DISCUSSION**

Chair Tallerico stated that he had concerns about the modification before reading the staff report, however it made sense and felt the proposal was straightforward and had no issues with it.

## **MOTION**

It was moved by Chair Tallerico, seconded by Commissioner Wilander to adopt Resolution No. 2188 approving Planning Commission Administrative Modification No. PC AM 25-05 for an updated parking plan at the Arcadia Hub Shopping Center located at 1201 to 1325 S. Baldwin Avenue, and 733, 745, and 815 W. Naomi Avenue in which the findings were made and is categorically exempt from CEQA.

## **ROLL CALL**

AYES:	Tallerico, Tsoi, Arvizu, Hui, and Wilander
NOES:	None
ABSENT:	None

The motion was approved.

*There is a ten (10) day appeal period. Appeals are to be filed by 4:30 p.m. on Friday, May 8, 2026.*

## **CONSENT CALENDAR**

1. Minutes of the April 14, 2026, Regular Meeting of the Planning Commission

**Recommendation:** Approve

Commissioner Arvizu motioned to approve the minutes and seconded by Commissioner Hui.

## **ROLL CALL**

AYES: Tallerico, Tsoi, Arvizu, Hui, and Wilander

NOES: None

ABSENT: None

The motion was approved.

## **MATTERS FROM CITY COUNCIL LIAISON**

Councilmember David Fu was not in attendance.

## **MATTERS FROM THE PLANNING COMMISSONERS**

There were none.

## **MATTERS FROM ASSISTANT CITY ATTORNEY**

Mr. Martz had nothing to report.

## **MATTERS FROM STAFF INCLUDING UPCOMING AGENDA ITEMS**

Ms. Flores stated that the revised Resolution No. 2187 will be before the Commission on May 12.

Ms. Flores reported that former mayor, George Fashing, passed away recently.

Ms. Flores reported that The Derby Mixed Use Project will not be moving forward because the owner will no longer pursue the project.

Ms. Flores informed the Commission that a new housing bill, Senate Bill (SB) 79, will go into effect July 1 and gave a brief background on the proposed changes.

**ADJOURNMENT**

The Planning Commission adjourned the meeting at 9:03 p.m., to Tuesday, May 12, 2026, at 7:00 p.m. in the City Council Chamber.



Chair Tallerico, Planning Commission

ATTEST:  \_\_\_\_\_  
Lisa L. Flores  
Secretary, Planning Commission



**ARCADIA PLANNING COMMISSION  
REGULAR MEETING MINUTES  
TUESDAY, MAY 12, 2026**

---

**CALL TO ORDER** Chair Tallerico called the meeting to order at 7:01 p.m.

**ROLL CALL**

PRESENT: Chair Tallerico, Vice Chair Tsoi, Commissioners Arvizu, Hui, and Wilander

ABSENT: None

**SUPPLEMENTAL INFORMATION FROM STAFF REGARDING AGENDA ITEMS**

Development Services Director, Lisa Flores, reported that one public comment was received via email prior to the meeting and it was forwarded to the Commissioners.

**PUBLIC COMMENTS (5 minute time limit per person)**

There were none.

**PUBLIC HEARING**

1. **Resolution No. 2187** – Denying Multi-Family SB 330 Application No. SB 330 25-01, Tentative Tract Map No. TTM 26-01 (84910), and Protected Healthy Tree Removal Permit No. TRH 26-02 for a new 30 unit, multi-family residential condominium development located at 514 Fairview Avenue

**Recommendation:** Adopt per the Planning Commission's Direction

**Applicant:** Eric Tsang on behalf of 518 Fairview, LLC

**DISCUSSION CONTINUED FROM THE APRIL 28, 2026, PLANNING COMMISSION MEETING**

Chair Tallerico introduced the item and Development Services Director Lisa Flores explained why there were two resolutions before the Commission. The first Resolution was the original Resolution for approval, and the second was for denial per the Planning Commission's decision at the last hearing.

Ms. Flores reminded the Planning Commissioners that the Housing Accountability Act (HAA) limits local agencies from denying a project or reducing its density if they meet all objective standards unless there is evidence that the project would result in a public health or safety threat.

Ms. Flores also informed the Planning Commission of the following:

1. She requested that the Commission convey which objective standards are of concern, as Staff is in the process of updating the City's objective standards and related processes; and
2. The California Department of Housing and Community Development (HCD) contacted the City regarding this project. A meeting was held with Ms. Flores and the Assistant City Attorney, during which HCD stated that, if a subsequent appeal is filed, it may submit a letter in support of the project. HCD also stated that a denial by the Planning Commission could constitute a potential violation; and
3. The City Manager's letter to the Planning Commission informed the Commissioners of the potential legal and financial risks to the City associated with a decision based on subjective grounds.

Chair Tallerico stated that under different circumstances he would agree with the City Manager but that the law must be challenged at times.

Commissioner Arvizu agreed and stated that he was standing by his vote to deny the project despite not having evidence of a public health or safety threat and making his decision on a subjective standard.

Vice Chair Tsoi stated that he is not opposed to the density or the design, however, he did not agree that one side of a through lot should be the rear yard area and the site will only have one point of ingress and egress.

Vice Chair Tsoi argued that the project did not meet the objective standards because the proposed common open spaces did not include passive or active amenities as stated in Development Code 9102.01.170.G. He stated that passive or active recreation amenities such as picnic/barbeque area, open courtyard, dog park/dog run, rooftop deck, fire pit area, or other outdoor gathering spaces shall be provided.

Ms. Flores responded that those amenities or items are examples of what could be placed in the common area but are not required.

Chair Tallerico agreed with the Commissioner's concerns and stated that he would be unhappy with the project if he lived in that neighborhood. Furthermore, he stated that his understanding about their role as the Planning Commission is to be strictly an advisory board to the City Council and that their decision has no bearing since the final decision maker is the City Council.

Ms. Flores reminded the Commissioners that it was a final decision, and this was not a recommendation to the City Council. It will only be before the City Council if the decision is appealed.

Mr. Maurer explained the difference between administrative and legislative items. He stated that administrative items involve applying the Development Code, while legislative items involve amending the Development Code. In this case, the decision is administrative, and this body is making a final decision on the item. However, the decision is subject to appeal, which is the process by which the matter could be brought before the City Council for review.

Chair Tallerico stated that regardless, the decision still stands with the City Council if someone appeals it.

Mr. Maurer agreed but wanted to be clear about the distinction.

## **MOTION**

It was moved by Commissioner Arvizu, seconded by Vice Chair Tsoi to adopt Resolution No. 2187 to deny Multi-Family SB 30 Application No. SB 330 25-01, Tentative Tract Map No. TTM 26-01 (84910), and Protected Healthy Tree Removal Permit No. TRH 26-02 for a new 30 unit, multi-family residential condominium development located at 514 Fairview Avenue

## **ROLL CALL**

AYES: Tallerico, Tsoi, and Arvizu  
NOES: Wilander and Hui  
ABSENT: None

The motion was approved.

*There is a ten (10) day appeal period. Appeals are to be filed by 4:30 p.m. on Friday, May 22, 2026.*

## **CONSENT CALENDAR**

1. Minutes of the April 28, 2026, Regular Meeting of the Planning Commission

**Recommendation:** Approve

Commissioner Wilander motioned to approve the minutes and seconded by Commissioner Arvizu.

## **ROLL CALL**

AYES: Tallerico, Tsoi, Arvizu, Hui, and Wilander

NOES: None

ABSENT: None

The motion was approved.

## **MATTERS FROM CITY COUNCIL LIAISON**

Councilmember David Fu reported that Mayor Eileen Wang has resigned.

## **MATTERS FROM THE PLANNING COMMISSIONERS**

Vice Chair Tsoi suggested adding the applicable code sections to the staff report for the waivers so that Commissioners and members of the public are better informed about standards relevant to the project.

Commissioner Arvizu asked about the waivers and how it was determined that three waivers should be granted.

Ms. Flores explained that the Development Code permits up to three (3) waivers, provided there is sufficient justification for each request.

## **MATTERS FROM CITY ATTORNEY**

Mr. Maurer had nothing to report.

## **MATTERS FROM STAFF INCLUDING UPCOMING AGENDA ITEMS**

Ms. Flores informed the Planning Commissioners that there will be items on the agenda for the next three meetings.

Ms. Flores reported that Commissioner Wilander's second term is coming to an end and her last meeting will be June 9, 2026, as she will be unable to attend the final meeting in June.

## **ADJOURNMENT**

The Planning Commission adjourned the meeting at 7:53 p.m., to Tuesday, May 26, 2026, at 7:00 p.m. in the City Council Chamber.



Chair Tallerico, Planning Commission

ATTEST:



\_\_\_\_\_  
Lisa L. Flores  
Secretary, Planning Commission



---

**DEVELOPMENT SERVICES DEPARTMENT**

**DATE:** April 28, 2026

**TO:** Honorable Chairperson and Planning Commission

**FROM:** Lisa L. Flores, Development Services Director  
By: Edwin Arreola, Senior Planner

**SUBJECT:** RESOLUTION NO. 2187 – APPROVING MULTI-FAMILY SB 330 APPLICATION NO. SB 330 25-01, TENTATIVE TRACT MAP NO. TTM 26-01 (84910), AND PROTECTED HEALTHY TREE REMOVAL PERMIT NO. TRH 26-02 FOR A NEW 30 UNIT, MULTI-FAMILY RESIDENTIAL CONDOMINIUM DEVELOPMENT LOCATED AT 514 FAIRVIEW AVENUE

**CEQA: Categorically Exempt**  
**Recommendation: Adopt**

**SUMMARY**

The Applicant, Eric Tsang, on behalf of the property owner 518 Fairview LLC, is requesting approval of Multi-Family SB 330 Application No. SB 330 25-01, Tentative Tract Map No. TTM 26-01 (84910), and Protected Healthy Tree Removal Permit No. TRH 26-02 for a new 30 unit, contemporary style, multi-family residential condominium development at 514 Fairview Avenue (“Project”). The Applicant has applied for a Preliminary Senate Bill (“SB”) 330 Application and the Project was deemed to be in compliance with SB 330 on July 24, 2025. Therefore, the Project is vested with the standards in effect at the time of the preliminary application submittal, is limited to no more than five public hearings, and is subject only to objective development standards. Furthermore, the proposed Project also includes the removal of 12 protected trees.

The proposed development and subdivision are consistent with the City’s General Plan, Development Code, and Subdivision Code. It is recommended that the Planning Commission find that the Project is Categorically Exempt under the California Environmental Quality Act (CEQA) under Section 15332 as a Class 32 infill development and adopt Resolution No. 2187 subject to the conditions listed in the staff report – refer to Attachment No. 1.

**BACKGROUND**

The subject site is located on the south side of Fairview Avenue over two existing lots (514 and 518 Fairview Avenue). The 514 Fairview Avenue lot is 28,870 square feet and the 518 Fairview Avenue lot is 28,925 square feet. Together, the site has a total area of approximately 57,795 square feet and is zoned High Density Residential (R-3) with a General Plan Land Use Designation of High Density Residential. Surrounding land uses also include other R-3 zoned properties to the north, east, south, and west. The Project site currently consists of a 1,672 square foot home, a 1,044 square foot home, a 738 square foot home, and several storage and barn structures – refer to Figure 1 below and Attachment No. 2 for an Aerial Photo with Zoning Information and Photos of the Subject Property and Vicinity.



**Figure 1** – Aerial of the Subject Site

The Project received preliminary approval through the SB 330 process under SB 330 Preliminary Application No. SB 330 PRELIM 25-04, which streamlines the review and approval of housing projects that comply with all zoning regulations and objective development standards in the Development Code. SB 330, enacted as part of the Housing Crisis Act of 2019, was subsequently amended by SB 8 (2022) and AB 1218 (2024) to further facilitate housing production.

Because the Project's SB 330 Preliminary Application was submitted on June 26, 2025, all applicable standards in effect at that time are vested. Accordingly, the Project is subject only to objective development standards, is not subject to design review, and is limited to no more than five public hearings. In addition, because the application was submitted prior to the City of Arcadia's Inclusionary Housing Ordinance effective July 1, 2025, the Project is not required to provide affordable units. The Project is also not utilizing the State Density Bonus Law.

The existing buildings on site will be demolished to accommodate the Project. The Development Code requires a Certificate of Demolition (COD) to be approved to demolish any structures over 50 years of age, while the residential structures on site were constructed in 1927. An evaluation by an Architectural Historian concluded that the structures do not meet the criteria for recognition as historical resources and are therefore not eligible for listing on the California Register or designation as local landmarks. The existing buildings are not considered significant examples of any specific architectural style, nor are they associated with any notable historical events or figures.

## **PROPOSAL**

The Applicant is proposing to combine the two existing lots into one lot through the Tentative Tract Map process to develop 30 three-story, multi-family units and subdivide the airspace of each of the units to allow for the sale of each residential condominium unit. In order to sell individual units for separate ownership, a tract map is required for the subdivision of airspace. SB 330 does not require a subdivision for multi-family projects and does not streamline the review process for maps associated with housing developments. As a result, all tract maps must still be reviewed by the Planning Commission through a public hearing – refer to Attachment No. 3 for the Tentative Tract Map and Figure 2 below for a Site Plan.

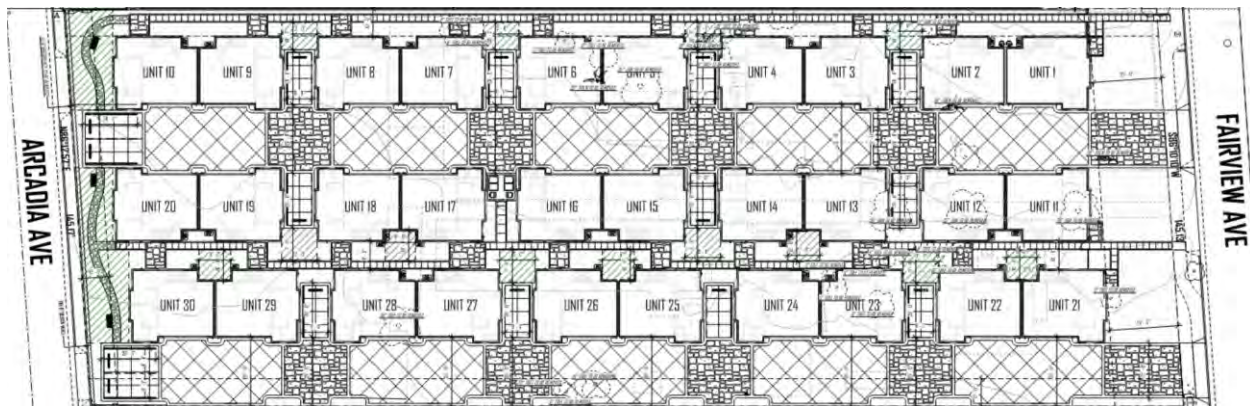

**Figure 2 – Site Plan**

The proposed 30 units will be built as 15 buildings, each containing two attached townhome style units. Each building includes one of two distinct floor plan types. Model A will consist of a 1,855 square foot four-bedroom unit and Model B will consist of a 1,867 square foot four-bedroom unit. Each building will reach the maximum allowed height of 30'-0" and the Project will meet the minimum required setbacks of 25'-0" at the front yard and 10'-0" for the rear and side yards. Each unit will have an attached two-car garage and the property will maintain code compliant common open space at the minimum rate of 100 square feet per unit. The Applicant is also proposing to subdivide the airspace to allow for the sale of each residential condominium unit – refer to Attachment No. 4 for the proposed Architectural Plans and Figure 3 below for a breakdown of the units.

<b>Number of Units</b>	<b>Square Feet</b>	<b>Bedrooms</b>	<b>Bathrooms</b>
15 (Model A)	1,855	4	4
15 (Model B)	1,867	4	4
30 Units Total			

**Figure 3 – Unit Size Table**

The buildings are designed in a Contemporary architectural style – as shown in Figure 4 below. The exterior walls of the buildings will be finished with white and charcoal colored stucco and wooden siding. It will be accented with bronze paneled garage doors, bronze windows, black light fixtures, and black rain gutters. The buildings will have a flat roof with mechanical equipment screened by parapets and will incorporate articulation in the form of steps back and cantilevers between the different levels of the building.

Access to the site will be provided off the north side of the property from Fairview Avenue via two separate driveways. 15 guest parking spaces will be provided on site. The backflow devices will be installed within the western portion of the front yard and a transformer will be installed within the central portion of the front yard. A condition has been included to provide screening for these utilities (see Condition No. 3). Mailboxes will be provided

adjacent to each driveway. Additionally, a bike rack with six bicycle parking spaces will be provided at the rear of the site.



**Figure 4** – Rendering of the design of the units

The proposal also includes the removal of 12 protected trees (11 Coast Live Oak trees and one California Sycamore tree) throughout the site – refer to Figure 5 below. The trees have the following issues which prevent them from being preserved:

- One 26" sycamore tree towards the southeast portion of the lot was deemed dead.
- Eight Coast Live Oak trees are located in the central portion of the site where development is proposed: three of these exhibit unbalanced canopies.
- One oak tree on the west side of the site, adjacent to a building footprint, exhibits a severe lean.
- One oak tree on the east side of the site is located within the proposed driveway area.
- Another oak tree on the east side of the site, also within the proposed driveway area, exhibits a severe lean.

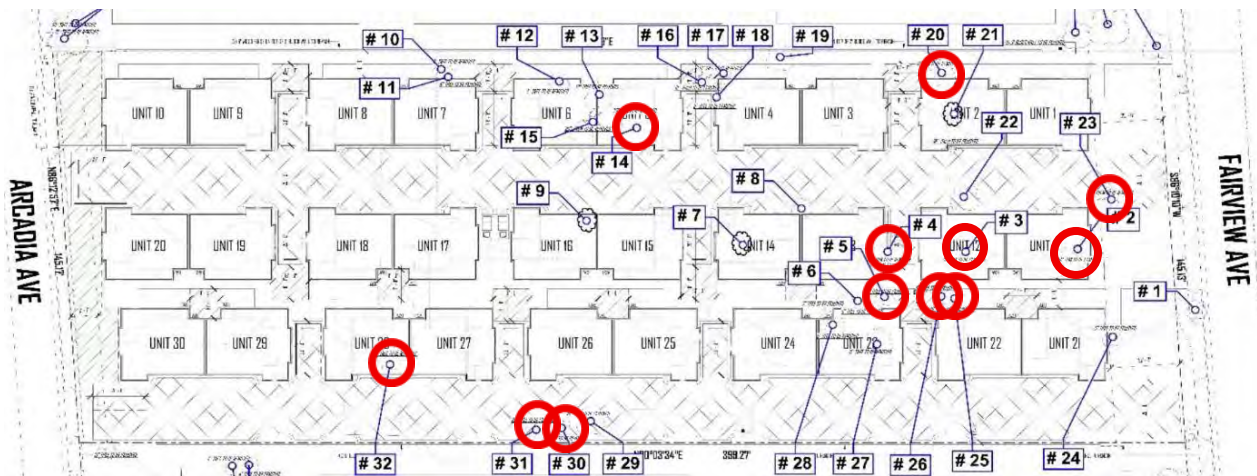

**Figure 5** – Location of the protected trees to be removed

These conditions, as determined by a Certified Arborist, indicate that the existing protected trees cannot survive development near their root area. Replacement landscaping will include four (4) 36-inch box Coast Live Oak trees, five (5) 24-inch box Forest Pansy trees, and five (5) 24-inch box Crape Myrtle trees. The oak trees will be located in the front yard, while the other replacement trees will be planted in available interior spaces between units.

Although the total number of replacement trees is below the 2:1 ratio required by code, site constraints include limited space and the large growth area required by oak trees preclude planting additional trees. The proposed four Coast Live Oak trees represent the maximum number that can successfully establish on the site, supplemented by the other replacement trees. Additional landscaping is proposed along the front of the site, adjacent to walkways and open spaces, and along the rear of the property adjacent to Arcadia Avenue.

### **ANALYSIS**

The R-3 zone requires a minimum density of one dwelling unit per 2,200 square feet of lot area, and a maximum density of one unit per 1,450 square feet of lot area. The subject property measures 57,795 square feet in area. This results in a minimum density of 26 units and a maximum of 39 units for the subject site; therefore, the proposed 30 unit development complies with the density requirements of the underlying R-3 Zone. Additionally, the Project will comply with other applicable development standards such as the front setback, height, open space, and parking requirements.

As such, and in accordance with SB 330, the Project has not been analyzed under the City's Multi-Family Residential Design Guidelines, as they are not applicable to the Project. The design is subject to review for consistency with the City's multi-family objective development standards. It has been confirmed that the design complies with all objective development standards except the three described below. The City's objective development standards allow for an Applicant to comply with all but up to three development standards to offer

some flexibility and to result in better architectural outcomes. Therefore, the Applicant is proposing to waive the following development standards:

1. Massing - For projects over two stories in height, portions of the upper stories shall be recessed at least two feet from the front façade to reduce the overall massing of the building at the pedestrian level.
2. Windows - Architectural window detailing, such as sills, trim, and/or awnings should be provided.
3. Trees - Existing mature trees should be preserved and incorporated into development proposals.

The proposed design recesses a significant portion of the third floor from the floors below, providing vertical articulation and reducing perceived massing. Additionally, the changes in materials and architectural breaks further articulate the different floors. Given the modern design of the development, which features simple window forms, additional detailing such as sills, trim, or awnings is not required to achieve visual interest. Moreover, preserving all existing mature trees on the site, many of which are located in the center and within buildable areas limits opportunities for additional setbacks. Therefore, the waivers being requested from the development standards are justified.

The proposed consolidation of the two existing lots into one, together with the airspace subdivision for the 30-unit, multi-family development, meets all applicable requirements of the Subdivision Map Act and the City's Development Code. The Map will subdivide the airspace to establish condominiums for individual sale, and no changes are proposed to the design, density, or physical improvements already approved for the Project. The subject site can be adequately served by existing utilities and public infrastructure. All necessary improvements and repairs will be secured as conditions of approval.

The proposed development and subdivision of condominiums will also be consistent with the City's General Plan, the Development Code, the State Subdivision Map Act, and will not violate any requirements of the California Regional Water Quality Control Board.

The removal of the 12 protected trees on site is warranted as the trees are located either within the center of the site or within proximity to the building footprint of the Project or driveway. Additionally, the protected California Sycamore tree on site is in poor health. An Arborist analyzed the potential for retaining the trees on site but due to their proximity to building foundations and driveway area, it was determined that preserving these trees while allowing the Project to be suitably developed per the Development Code would be infeasible and the trees would need to be removed – refer to Attachment No. 5 for the Arborist Report. Therefore, the Arborist has determined that an appropriate replacement for the site is to plant a minimum of four (4) 36-inch box Coast Live Oak trees, five (5) 24-inch box Forest Pansy trees, and five (5) 24-inch box Crape Myrtle trees for the removal of the protected

trees. A condition has been added to ensure that replacement trees are planted and that a follow up Arborist Report is required confirming the planting prior to issuance of a Certificate of Occupancy.

## **FINDINGS**

Sections 9103.15.040 and 9105.03.060(A)(1) of the Development Code require that for a Tentative Tract Map to be granted, it must be found that all of the following prerequisite findings can be satisfied:

### Tentative Tract Map

- 1. The proposed map, subdivision design, and improvements are consistent with the General Plan, any applicable specific plan, and the Subdivisions Division of the Development Code.**

**Facts to Support This Finding:** The Project is in compliance with all of the provisions of the City's General Plan, Subdivisions Division of the Development Code, and the State Subdivision Map Act. It has been determined that the proposed subdivision is consistent with the General Plan High Density Residential Land Use designation and the R-3, High Density Multiple Family Residential zoning designation. These designations are intended to accommodate high density, attached or detached residential units such as condominiums, within the appropriate neighborhoods. The proposed Tentative Parcel Map complies with the Subdivision Map Act regulations, and there is no specific plan applicable to this Map. The site is physically suitable for the approved condominium project. The Map would not adversely affect the comprehensive General Plan and is consistent with the following General Plan goal and policy:

### Land Use and Community Design Element

- Policy LU-1.1: Promote new infill and redevelopment projects that are consistent with the City's land use and compatible with surrounding existing uses.
- Policy H-2.3: Encourage compatible residential development in areas on underutilized land.
- Policy H-2.4: Maintain development standards, regulations, and design features that are flexible to provide a variety of housing types and facilitate housing that is appropriate for the neighborhoods in which they are located.
- Policy H-4.4: Support infill development at appropriate locations in the City.

**2. The site is physically suitable for the type and proposed density of development.**

**Facts to Support This Finding:** The R-3 Zone requires a minimum density of one dwelling unit per 2,200 square feet of lot area, and a maximum density of one unit per 1,450 square feet of lot area. Based on the lot area of 57,795 square feet, a minimum of 26 units and a maximum of 39 units could be developed at this site. Therefore, the proposed 30-unit development complies with the density requirements of the underlying zone, as well as all other applicable zoning requirements including but not limited to parking, setbacks, height, and open space. Therefore, the site is physically suitable for the Project.

**3. The design of the subdivision and the proposed improvements are not likely to cause substantial environmental damage or substantially and avoidably injure fish or wildlife or their habitat.**

**Facts to Support This Finding:** The Project is a subdivision of an infill site within an urbanized area and does not serve as a habitat for endangered or rare species. The Project will not cause substantial environmental damage or impact wildlife.

**4. The design of the subdivision or type of improvements is not likely to cause serious public health or safety problems.**

**Facts to Support This Finding:** The Project is to subdivide the airspace of the proposed multi-family development. The Project will be in compliance with all applicable Building and Fire Codes to ensure public health and safety. The proposed density will comply with the allowed density by the R-3 zone and the City's existing infrastructure will adequately serve the Project. Therefore, the Project will not cause any public health or safety problems.

**5. The design of the subdivision or the type of improvements will not conflict with easements acquired by the public at large for access through or use of, property within the proposed subdivision (This finding shall apply only to easements of record or to easements established by judgement of a court of competent jurisdiction and no authority is hereby granted to a legislative body to determine that the public at large has acquired easements for access through or use of property within the proposed subdivision).**

**Facts to Support This Finding:** The proposed design of the subdivision does not conflict with easements acquired by the public at large for access through or use of property within the proposed subdivision. There are no known easements on the subject property. Therefore, the Project will not conflict with any such easements.

**6. The discharge of sewage from the proposed subdivision into the community sewer system will not result in violation of existing requirements specified by the California Regional Water Quality Control Board.**

**Facts to Support This Finding:** The Arcadia Public Works Services Department determined that the City's existing infrastructure will adequately serve the Project. The discharge of sewage from the Project into the community sewer system will not result in violation of existing requirements specified by the California Regional Water Quality Control Board.

**7. The proposed subdivision, its design, density, and type of development and improvements conforms to the regulation of the Development Code and the regulations of any public agency having jurisdiction by law.**

**Facts to Support This Finding:** The approved development and the proposed subdivision of the airspace for the multi-family development is in conformance with the City's Development Code, as all development standards are being met, and all of the improvements required for the site would comply with the regulations in the City's Development Code and requirements of any public agency having jurisdiction by law.

Removal of a Healthy Protected Tree

**8. The removal of the trees is necessary.**

**Facts to Support This Finding:** The Project will require the removal of 12 protected trees on site which includes 11 Coast Live Oak trees and one California Sycamore tree. The removal of these protected trees is necessary as they are located at the center of the site and within the footprint of the proposed building foundations and driveway areas. Additionally, five of the oak trees exhibit unbalanced canopies, and one Sycamore tree is in poor health.

A Certified Arborist evaluated the potential to retain the trees on site; however, due to the proximity to proposed building foundations, it was determined that the protected trees would not have sufficient space to support healthy growth if preserved. Therefore, the Arborist has recommended their removal.

**9. The removal of the trees is more desirable than alternative project designs.**

**Facts to Support This Finding:** The location of many of the protected trees near the center of the site limits the feasibility of alternative project designs that would avoid their removal. The trees are distributed throughout the central portion of the site, leaving

limited access to the interior of the lot, while only the rear portion remains free of protected trees.

Additionally, because most of the protected trees are Coast Live Oak trees, they require substantial protection areas to accommodate root and canopy growth. These protection requirements would significantly reduce the buildable area of the site and may restrict development to projects that only meet the minimum allowable density.

**10. Mitigation measures will be applied for the removal of the trees.**

**Facts to Support This Finding:** The Certified Arborist who reviewed the protected trees on site has recommended that the Applicant plant a minimum of four (4) 36-inch box Coast Live Oak trees, five (5) 24-inch box Forest Pansy trees, and five (5) 24-inch box Crape Myrtle trees for the removal of the protected trees.

The site can only accommodate up to four Coast Live Oak trees within the front yard of the site, providing sufficient space for their root and canopy extension. Additionally, the Certified Arborist recommended installing root barriers along the driveways, walkways, and building foundations to prevent potential root damage from the growth of the replacement trees. Based on these measures, the removal of the healthy protected trees is warranted to accommodate the proposed development.

**ENVIRONMENTAL IMPACT**

It has been determined that the project site is less than five (5) acres; the project site has no value as a habitat for endangered, rare or threatened species; the proposed project will not have any significant effects upon the environment, and the site can be adequately served by all the required utilities and public services. Therefore, the Map is exempt under Class 32 (In-Fill Development Projects) pursuant to Section 15332 of the State California Environmental Quality Act (CEQA) Guidelines - refer to Attachment No. 6 for the Preliminary Exemption Assessment.

**PUBLIC COMMENTS/NOTICE**

A public hearing notice for this item was posted at the City Clerk's Office, City Council Chambers, at the Arcadia Library, and on the City's website on April 16, 2026. It was also mailed to the property owners located within 300 feet of the subject property. As of April 24, 2026, no comments were received.

**RECOMMENDATION**

It is recommended that the Planning Commission adopt Resolution No. 2187 recommending approval of Multi-Family SB 330 Application No. SB 330 25-01, Tentative Tract Map No. TTM 26-01 (84910), and Protected Healthy Tree Removal Permit No. TRH 26-02 and find that the Project is Categorically Exempt from the California Environmental Quality Act (CEQA), subject to the following conditions of approval:

### Planning

1. The Project shall be developed and maintained by the Property Owner/Applicant in a manner that is consistent with the plans submitted and conditionally approved for Multi-Family SB 330 Application No. SB 330 25-01, Tentative Tract Map No. TTM 26-01 (84910), and Protected Healthy Tree Removal Permit No. TRH 26-02, subject to the satisfaction of the Development Services Director or designee.
2. Prior to final inspection, a minimum of four (4) 36-inch box Coast Live Oak trees, five (5) 24-inch box Forest Pansy trees, and five (5) 24-inch box Crape Myrtle trees shall be planted on the subject site as replacement trees. A Landscape Plan in compliance with the City's Water Efficient Landscape Ordinance shall be prepared and provided with the building plan-check submittal. Said replacement trees must be shown on the Landscape Plan and are subject to review and approval by the Planning Division. A follow-up report by a Certified Arborist confirming the replacement trees have been planted shall be submitted to the City prior to issuance of a Certificate of Occupancy.
3. Any required mechanical equipment, such as backflow devices and transformers, visible from the public right-of-way shall be screened from public view. Screening may include landscaping, solid walls or other methods deemed appropriate for the development.

### Building

4. The plans that are submitted to Building Services for plan-check shall comply with the latest adopted edition of the following codes as applicable:
  - a. California Building Code (CBC)
  - b. California Electrical Code
  - c. California Mechanical Code
  - d. California Plumbing Code
  - e. California Energy Code
  - f. California Fire Code
  - g. California Green Building Standards Code
  - h. California Existing Building Code
  - i. Arcadia Municipal Code
5. Grading plans shall be submitted with the building plan-check submittal, and are to be approved by Engineering, Planning and Building Services prior to the issuance of

building permits. The grading plans shall indicate all site improvements and shall indicate complete drainage paths of all drainage water run-off.

6. A demolition permit shall be obtained from Building Services prior to the removal and/or demolition of the structures on site.

#### Engineering

7. The Property Owner/Applicant shall be responsible for the repair of all damage to public improvements in the public right-of-way resulting from construction related activities, including, but not limited to, the movement and/or delivery of equipment, materials, and soils to and/or from the site. The need for such repair shall be determined by the Development Services Director, the Public Works Services Director, City Engineer, or designees, during construction and up until issuance of a Certificate of Occupancy.
8. The proposed development will be required to adhere to Los Angeles County Low Impact Development (LID) requirements. All LID measures must be implementable within the property. A LID plan, showing the selected measures, shall be provided along with the grading and drainage plan. A Master Covenant for the LID and Maintenance Plan shall be recorded with the Los Angeles County Recorder prior to occupancy.
9. A hydrology report and a soils/geotechnical report shall be submitted with the plan check submittal to Building Services.
10. Prior to recordation of the final tract map, the Property Owner/Applicant shall complete the construction of or execute and provide a Subdivision Map Agreement and bond to the City for the following off-site improvements:
  - a. Remove the existing driveway approaches and construct new driveway approaches per the City Standard. Ensure Americans with Disabilities Act (ADA) access is provided around all driveway approaches within City right-of-way and development property lines. Improvements shall not encroach into neighboring properties/frontages.
  - b. Remove the existing sidewalk and construct a new sidewalk per City Standard providing adequate path of travel in compliance with ADA. Ensure locations around obstructions provide necessary clearances.
11. Prior to issuance of a certificate of occupancy, the Property Owner/Applicant shall repair any damages caused by the development to the asphalt street frontages from property line to property line including but not limited to trench cuts and construction traffic, per the direction of the City Engineer.

#### Fire Department

12. All structures shall be provided with an automatic fire sprinkler system per the City of Arcadia Fire Department's Single & Multi-Family Dwelling Sprinkler Standard.

Public Works

13. The Property Owner/Applicant shall utilize the existing sewer lateral(s) if possible. If any drainage fixture elevation is lower than the elevation of the next upstream manhole cover, an approved backwater valve will be required.
14. In order to verify the required water service size for the Project, the Property Owner/Applicant shall submit to the Public Works Services Department calculations for the maximum domestic use demand and maximum fire demand prior to the issuance of a building permit. Fire protection requirements shall be as stipulated by the Arcadia Fire Department and shall conform to the Arcadia Standard Plan.
15. Prior to the issuance of a building permit, the Property Owner/Applicant shall submit a Water Meter Permit Application to the Public Works Services Department.
16. The Property Owner/Applicant shall provide a new water service installation. Installation shall be according to the specifications of the Public Works Services Department, Engineering Division. Abandonment of existing water services, if necessary, shall be completed by the Property Owner/Applicant, according to Public Works Services Department, Engineering Section specifications.
17. The Applicant/Property Owner shall comply with the General Construction National Pollutant Discharge Elimination System (NPDES) Permit, submit a Notice of Intent (NOI) and pay applicable fees to the State Water Resources Control Board, and prepare a Storm Water Pollution Prevention Plan (SWPPP).

General

18. The Property Owner/Applicant shall comply with all City requirements regarding building safety, fire prevention, detection, suppression, emergency access, public right-of-way improvements, parking, water supply and water facilities, sewer facilities, trash reduction and recycling requirements, and National Pollutant Discharge Elimination System (NPDES) measures, all to the satisfaction of the Building Official, Fire Marshal, Public Works Services Director, and Deputy Development Services Director. Compliance with these requirements is to be determined by having fully detailed construction plans submitted for plan check review and approval by the foregoing City officials and employees.
19. To the maximum extent permitted by law, Applicant must defend, indemnify, and hold the City, any departments, agencies, divisions, boards, and/or commissions of the City, and its elected officials, officers, contractors serving as City officials, agents, employees, and attorneys of the City ("Indemnitees") harmless from liability for damages and/or claims, actions, or proceedings for damages for personal injuries, including death, and claims for property damage, and with respect to all other actions and liabilities for

damages caused or alleged to have been caused by reason of the Applicant's activities in connection with SB 330 25-01, TTM 26-01, and TRH 26-02 ("Project") on the Project site, and which may arise from the direct or indirect operations of the Applicant or those of the Applicant's contractors, agents, tenants, employees or any other persons acting on Applicant's behalf, which relate to the development and/or construction of the Project. This indemnity provision applies to all damages and claims, actions, or proceedings for damages, as described above, regardless of whether the City prepared, supplied, or approved the plans, specifications, or other documents for the Project.

In the event of any legal action challenging the validity, applicability, or interpretation of any provision of this approval, or any other supporting document relating to the Project, the City will notify the Applicant of the claim, action, or proceedings and will cooperate in the defense of the matter. The Applicant must indemnify, defend and hold harmless the Indemnitees, and each of them, with respect to all liability, costs and expenses incurred by, and/or awarded against, the City or any of the Indemnitees in relation to such action. Within 15 days' notice from the City of any such action, the Applicant shall provide to the City a cash deposit to cover legal fees, costs, and expenses incurred by City in connection with defense of any legal action in an initial amount to be reasonably determined by the City Attorney. The City may draw funds from the deposit for such fees, costs, and expenses. Within 5 business days of each and every notice from the City that the deposit has fallen below the initial amount, Applicant/Property Owner shall replenish the deposit each and every time in order for City's legal team to continue working on the matter. The City shall only refund to the Applicant/Property Owner any unexpended funds from the deposit within 30 days of: (i) a final, non-appealable decision by a court of competent jurisdiction resolving the legal action; or (ii) full and complete settlement of legal action. The City shall have the right to select legal counsel of its choice. The parties hereby agree to cooperate in defending such action. The City will not voluntarily assist in any such third-party challenge(s). In consideration for approval of the Project, this condition shall remain in effect if the entitlement(s) related to this Project is rescinded or revoked, at the request of the Applicant or not.

20. Approval of Multi-Family SB 330 Application No. SB 330 25-01, Tentative Tract Map No. TTM 26-01 (84910), and Protected Healthy Tree Removal Permit No. TRH 26-02 shall not be in effect unless the Property Owner and Applicant have executed and filed the Acceptance Form with the City on or before 30 calendar days after the Planning Commission has adopted the Resolution. The Acceptance Form to the Development Services Department is to indicate awareness and acceptance of the conditions of approval.

## **PLANNING COMMISSION ACTION**

Approval

If the Planning Commission intends to approve this Project, the Commission should move to approve Resolution No. 2187 approving Multi-Family SB 330 Application No. SB 330 25-01, Tentative Tract Map No. TTM 26-01 (84910), and Protected Healthy Tree Removal Permit No. TRH 26-02 and state that the proposal satisfies the requisite environmental and subdivision findings, and the conditions of approval as presented in this staff report, or as modified by the Commission.

Denial

If the Planning Commission intends to deny this subdivision, the Commission should state the specific findings that the subdivision does not satisfy based on the evidence presented with specific reasons for denial and move to deny Multi-Family SB 330 Application No. SB 330 25-01, Tentative Tract Map No. TTM 26-01 (84910), and Protected Healthy Tree Removal Permit No. TRH 26-02 and direct staff to prepare a resolution for adoption at the next meeting that incorporates the Commission's decision and specific findings.

If any Planning Commissioner, or other interested party has any questions or comments regarding this matter prior to the April 28, 2026, Planning Commission Meeting, please contact Senior Planner, Edwin Arreola, at (626) 821-4334 or by email at earreola@ArcadiaCA.com.

Approved:



Lisa L. Flores  
Development Services Director

- Attachment No. 1: Resolution No. 2187
- Attachment No. 2: Aerial Photo with Zoning Information and Photos of the Subject Property and Vicinity
- Attachment No. 3: Tentative Tract Map
- Attachment No. 4: Architectural Plans
- Attachment No. 5: Arborist Report
- Attachment No. 6: Preliminary Exemption Assessment



---

**DEVELOPMENT SERVICES DEPARTMENT**

**DATE:** May 12, 2026

**TO:** Honorable Chairperson and Planning Commission

**FROM:** Lisa Flores, Development Services Director

**SUBJECT:** RESOLUTION NO. 2187 – DENYING MULTI-FAMILY SB 330 APPLICATION NO. SB 330 25-01, TENTATIVE TRACT MAP NO. TTM 26-01 (84910), AND PROTECTED HEALTHY TREE REMOVAL PERMIT NO. TRH 26-02 FOR A NEW 30 UNIT, MULTI-FAMILY RESIDENTIAL CONDOMINIUM DEVELOPMENT LOCATED AT 514 FAIRVIEW AVENUE

**Recommendation: Adopt per the Planning Commission’s Direction**

**SUMMARY**

At the April 28, 2026, the Planning Commission meeting, the Commission considered a proposed 30-unit, contemporary style, multi-family residential condominium project at 514 Fairview Avenue (“Project”). The project includes a Multi-Family SB 330 Application No. SB 330 25-01, Tentative Tract Map No. TTM 26-01 (84910), and Protected Healthy Tree Removal Permit No. TRH 26-02 for the removal of 11 protected trees.

There was significant discussion regarding SB 330, requests for waivers from the City’s objective development and design standards under the Development Code, and neighborhood compatibility. As stated during the meeting, the waiver provisions referenced are not part of SB 330 but instead were established by the City through its own Development Code.

These provisions were intentionally created as a local process to allow limited flexibility from certain objective development/design standards to achieve higher quality, more aesthetically cohesive building designs where strict application of all standards may not produce the best outcome. Under this process, an Applicant may request a waiver with supporting justification, and the Review Authority (the Director or designee, which is the Planner) evaluates the request in accordance with the City’s adopted criteria.

The Development Services Director and the Assistant City Attorney informed the Planning Commission that the Housing Accountability Act (HAA) limits a local agency's ability to deny or reduce the density of a housing development that complies with all the applicable, objective standards. The only way a project can be denied is if there is evidence that the project would result in a specific, adverse impact on public health or safety, and there is no feasible method to mitigate or avoid the impact.

After hearing the two residents who were opposed to the project including the five (5) letters that were submitted to the Planning Commission prior to the meeting, the Commission expressed concerns regarding the project's height and mass, finding it incompatible with the surrounding development. The Commission subsequently voted 4-1 to deny the project, with Commissioner Wilander dissenting, and directed staff to return with a revised Resolution at the May 12 meeting (refer to Attachment No. 1).

Following the Planning Commission meeting, the City was contacted by the California Department of Housing and Community Development (HCD), which indicated it had been informed of a potential violation of the Housing Accountability Act (HAA) related to the Commission's action. The City has a meeting with HCD to discuss this matter and they further state that they will continue to monitor the matter going forward.

In a letter dated May 7 to the Planning Commission, the City Manager explained that denying an SB 330 project on subjective grounds - such as perceived scale or neighborhood character - is generally not supported under State law and may expose the City to significant legal and financial risks, including potential impacts to the City and its taxpayers (refer to Attachment No. 2).

In addition to the revised Resolution for denial, the agenda packet also includes the original approval version of the Resolution – refer to Attachment No. 3. At the May 12 meeting, the Planning Commission will have the opportunity to reconsider its prior action considering the applicable legal standards and the administrative record.

If the Commission elects to deny the Project, it must identify specific adverse health or safety impacts and include objective, quantifiable facts in the record to support those findings. If such findings cannot be made, approval of the Project would be warranted.

### **RECOMMENDATION**

It is recommended that the Planning Commission re-evaluate the project based on applicable objective development standards and applicable State housing laws. Concerns

Resolution No. 2187 – 514 Fairview Avenue

May 12, 2026

Page 3 of 3

related to perceived building mass, scale, or neighborhood character do not generally constitute legally sufficient grounds for denial under SB 330 or the Housing Accountability Act (HAA). Any recommendation for denial would need to be supported by substantial evidence demonstrating a specific, adverse impact upon public health or safety that cannot be feasibly mitigated.

If any Planning Commissioners have questions or would like to discuss this matter further, please contact the City Manager, as noted in his letter to the Planning Commissioners, at [domlazz@arcadiaca.gov](mailto:domlazz@arcadiaca.gov) or (626) 574-5401; the City Attorney's Office; or me at [lflores@arcadiaca.gov](mailto:lflores@arcadiaca.gov) or (626) 574-5445.

Approved:



Lisa L. Flores

Development Services Director

Attachment No. 1: Resolution No. 2187 – Denial per the Planning Commission's recommendation

Attachment No. 2: Letter from the City Manager, dated May 7, 2026

Attachment No. 3: Resolution No. 2187 - Approval

# Attachment No. 6

Public Comments

## Edwin Arreola

---

**From:** Linda Rodriguez  
**Sent:** Monday, April 27, 2026 12:15 PM  
**To:** Edwin Arreola; Ivette Torres  
**Cc:** Arcadia City Clerk  
**Subject:** FW: Subject: Public Comment – 514 Fairview Avenue Project (Resolution No. 2187)

Hello,

FYI - see email below addressed to the Planning Commission.

Thank you,



### Linda Rodriguez, CMC

City Clerk  
240 W Huntington Dr, Arcadia, CA 91007  
(626) 574-5454



---

**From:** Lirong Zeng <lirongzeng1111@gmail.com>  
**Sent:** Monday, April 27, 2026 11:51 AM  
**To:** Arcadia City Clerk <CityClerk@arcadiaca.gov>  
**Subject:** Subject: Public Comment – 514 Fairview Avenue Project (Resolution No. 2187)



**IRONSCALES couldn't recognize this email as this is the first time you received an email from this sender**  
lirongzeng1111@gmail.com

**CAUTION:** This email originated from outside your organization. Exercise caution when opening attachments or clicking links, especially from unknown senders.

Email Body:

Dear Planning Commission,

My name is Lirong Zeng, and I reside at 530 Fairview Ave #12, Arcadia, CA 91007, directly behind the proposed development at 514 Fairview Avenue.

I am writing to express my concerns regarding this project.

The proposed 30-unit multi-family development will be built directly behind my living room and bedroom. The height and density of the building will significantly impact my privacy, as upper-floor units will overlook my home.

In addition, the removal of existing trees will eliminate shade and privacy. Without these trees, my home will become noticeably hotter, and I will lose what little privacy I currently have.

I am also concerned about construction impacts, including noise, dust, and general disturbance during the building process. After completion, the increased number of residents will lead to more congestion, higher noise levels, and insufficient street parking in an already limited area.

I respectfully request that the Commission carefully consider the impacts on nearby residents and take the following into account:

- Reduce the building height
- Increase setbacks from adjacent properties
- Preserve existing trees where possible or require meaningful replacement
- Provide adequate privacy screening such as landscaping or fencing
- Limit construction hours to reduce noise and disturbance

I am not opposed to development, but I strongly urge that this project be designed in a way that respects the quality of life of existing residents.

Thank you for your time and consideration.

Sincerely,  
Lirong Zeng  
530 Fairview Ave #12  
Arcadia, CA 91007

## Edwin Arreola

---

**From:** susan rogers <colsue58@gmail.com>  
**Sent:** Monday, April 27, 2026 12:21 PM  
**To:** Edwin Arreola  
**Subject:** April 28 meeting



**IRONSCALES couldn't recognize this email as this is the first time you received an email from this sender**  
colsue58@gmail.com

CAUTION: This email originated from outside your organization. Exercise caution when opening attachments or clicking links, especially from unknown senders.

Mr. Arreola, my name is Susan Rogers and I live at Villa Fleurie. I will be significantly impacted by the new proposal project for 514 Fairview Ave. I would like to speak at the meeting to discuss my concerns and need to know what your protocols are so I can do it appropriately. Thank for you help.

Susan Rogers, 530 Fairview Ave. Unit 2.

Sent from my iPad

## Edwin Arreola

---

**From:** Hana Kim <hanasmiles16@gmail.com>  
**Sent:** Tuesday, April 28, 2026 7:10 AM  
**To:** Edwin Arreola; Mailbox - Planning  
**Cc:** Recstaff; Sara Somogyi; Eileen Wang; Arcadia City Clerk; City of Arcadia PW  
**Subject:** Re: Public Comment - 514- 518 Fairview Avenue APN: 5778- 005- 012 & 5778- 005- 013

CAUTION: This email originated from outside your organization. Exercise caution when opening attachments or clicking links, especially from unknown senders.

Hello,

I wanted to follow up on my earlier comment regarding the April 28 hearing for 514–518 Fairview Avenue.

After reviewing the site location more carefully, I understand that the proposed development is on a nearby parcel and not the specific green space I initially believed it to be.

That said, I remain interested in how this project may impact the surrounding neighborhood, including tree canopy, privacy, and overall character, and I appreciate the opportunity for community input.

Thank you again for your time.

Respectfully,  
Hana Kim

On Mon, Apr 27, 2026 at 11:15 AM Hana Kim <[hanasmiles16@gmail.com](mailto:hanasmiles16@gmail.com)> wrote:

\*\*Please include this correspondence in the public record and share it with the Planning Commission.

Hello Mr. Arreola,

I am a nearby resident writing regarding the April 28 hearing for 514–518 Fairview Avenue.

I grew up in Arcadia and have known the community since childhood (class of 2007). After moving back as an adult, I found that many parts of the city had changed and become almost unrecognizable. Fairview Avenue, however, still retained much of the quiet character and natural beauty I remember from when I used to ride my bike through the neighborhood as a child.

I only recently became aware of this proposal and believe many nearby residents may not yet know of the hearing. I respectfully request consideration of a continuance so the surrounding community has a fair opportunity to review and comment.

I am especially concerned about the proposed removal of numerous mature protected trees, including oak trees and a sycamore. These trees are far older than I am and represent decades of growth, shade, environmental value, and neighborhood character that cannot be meaningfully replaced in the short term.

In addition, this green open area appears to function as an important informal outdoor space for neighborhood families. I regularly observe many children using and gathering around this area. In a community with many families, accessible nearby outdoor spaces matter greatly, especially for children who benefit from having safe places close to home rather than destinations far away.

These mature trees also appear to support local songbirds and other urban wildlife that rely on established canopy and green space for shelter and refuge.

I respectfully ask that the Commission carefully review alternatives that maximize tree preservation, evaluate whether replacement plans are truly adequate, and consider neighborhood impacts such as privacy, traffic, and construction disruption.

Thank you for your time and consideration.

Respectfully,

Hana Kim  
Arcadia Resident

## Edwin Arreola

---

**From:** Suki Wong <sukissw@gmail.com>  
**Sent:** Tuesday, April 28, 2026 3:53 PM  
**To:** Mailbox - Planning; Edwin Arreola  
**Subject:** Strong Objection to Proposed 30-Unit Project



IRONSCALES couldn't recognize this email as this is the first time you received an email from this sender  
sukissw@gmail.com

CAUTION: This email originated from outside your organization. Exercise caution when opening attachments or clicking links, especially from unknown senders.

**Dear Planning Services Committee and Edwin,**

I am a resident of Fairview/La Cadena area writing to formally express my strong opposition to the proposed 30-unit development on 514-518 Fairview Ave. While I understand the need for housing, this specific proposal represents an unsustainable level of density that the current local infrastructure cannot support.

My concerns are centered on the following critical issues:

### **1. Severe Parking Deficiency & Unrealistic Residential Estimates**

The proposal allocates only 15 guest parking spaces for 30 units. Given that each unit exceeds **1,800 square feet** and includes a **two-car garage**, these are clearly designed as family-sized homes or multi-adult residences.

- It is statistically unrealistic to assume these units will only generate two vehicles per household.
- When residents exceed the two-car garage capacity, or when guests visit, the 15-space allotment will be exhausted immediately.
- The developer's reliance on "minimum state requirements" ignores the practical reality of how a 30-unit complex operates.

### **2. Existing Infrastructure Oversaturation**

Our neighborhood has reached a breaking point regarding street capacity. The current concentration of condos and apartments has already eliminated available street parking.

- Emergency vehicle access and resident safety are already compromised by the existing congestion.
- Adding 30 high-density units to a single family house lot without adequate internal parking will force the overflow onto streets that are already 100% saturated.

### **3. Impact on Community Livability and Safety**

This project appears to prioritize maximum unit yield over the long-term livability and safety of the neighborhood. Overdevelopment without concurrent infrastructure improvements places an undue burden on existing tax-paying residents.

I urge the Committee to deny this proposal in its current form or require a significant reduction in unit count alongside a substantial increase in on-site guest parking. We must ensure that new developments contribute to the community rather than depleting its remaining resources.

Thank you for your time and for considering the concerns of the residents who will be most affected by this decision.

Sincerely,

Suki W.

## Edwin Arreola

---

**From:** Kristy Wong <kristy\_wong@hotmail.com>  
**Sent:** Tuesday, April 28, 2026 4:55 PM  
**To:** Mailbox - Planning; Edwin Arreola  
**Subject:** Objection to Proposed 30-Unit Development on 514-518 Fairview Avenue



IRONSCALES couldn't recognize this email as this is the first time you received an email from this sender  
kristy\_wong@hotmail.com

CAUTION: This email originated from outside your organization. Exercise caution when opening attachments or clicking links, especially from unknown senders.

Dear Members of the Planning Committee,

I am a resident of La Cadena Avenue and would like to express my strong objection to the proposed 30-unit development on Fairview Avenue. Recent condominium developments have already increased traffic and made parking on La Cadena Avenue very limited.

This project proposes large units (approximately 1,800 sq ft) with only two parking spaces each and minimal guest parking. This is not sufficient and will likely result in significant street parking overflow, further worsening an already difficult situation.

Additionally, traffic safety is a concern. It is currently challenging to turn at the intersection of La Cadena Avenue and Duarte Ave, and increased traffic will make this more dangerous. A traffic signal at this intersection should be considered.

I respectfully ask the committee to reconsider or revise this project to address parking and traffic impacts.

Thank you for your time and consideration.

Sincerely,  
Kristy W.

Sent from my iPhone

## Edwin Arreola

---

**From:** Rachel Wong <rachelnwong00@gmail.com>  
**Sent:** Tuesday, April 28, 2026 5:00 PM  
**To:** Mailbox - Planning; Edwin Arreola  
**Subject:** Objection to Proposed 30-Unit Development on 514-518 Fairview Avenue

<[https://members.ironstakes.com/static/webapp/images/iron\\_icon\\_color\\_7\\_2021.png](https://members.ironstakes.com/static/webapp/images/iron_icon_color_7_2021.png)> IRONSTAKES couldn't recognize this email as this is the first time you received an email from this sender rachelnwong00 @ gmail.com

CAUTION: This email originated from outside your organization. Exercise caution when opening attachments or clicking links, especially from unknown senders.

Dear Members of the Hearing Board,

I am a resident in the neighbourhood and write to formally object to the proposed 30-unit residential development currently under review. I respectfully request that the Board give serious consideration to the significant and demonstrable impacts this project would impose on the surrounding community.

The proposed development would place 30 units, each approximately 1,800 square feet in size and equipped with a two-car garage, on a lot that previously accommodated only two single-family residences. This represents an extraordinary intensification of land use that is wholly incompatible with the existing infrastructure of our neighbourhood.

My primary concern is parking. The proposal provides only 15 guest parking spaces for the entire complex. While this figure may satisfy the minimum threshold under state law, it is plainly insufficient in practical terms. Given that each unit exceeds 1,800 square feet and includes a two-car garage, these are clearly designed as family-sized homes or multi-adult residences. It is statistically unrealistic to assume these units will only generate two vehicles per household. As a result, any additional vehicles of residents and guests, service vehicles, and any overflow will have nowhere to park on-site. This burden will fall directly on surrounding streets that are already severely oversaturated due to the high concentration of condominiums and apartment buildings in the immediate area. Available on-street parking for existing residents is already extremely limited, and in many cases nonexistent at peak hours.

This chronic overcrowding of our streets poses a serious public safety risk that cannot be overlooked. Emergency vehicles, including fire trucks, ambulances, and police units, require clear and unobstructed access to respond to incidents in a timely manner. With streets already congested beyond capacity, any further reduction in available roadway clearance caused by this development could critically delay emergency response times, placing the lives of all residents in jeopardy.

This proposal, as submitted, prioritizes the financial interests of the developer while disregarding the quality of life, safety, and basic daily needs of the residents who already call this neighbourhood home. Adding 30 units under these conditions will meaningfully worsen an already strained situation.

I respectfully urge the Board to:

1. Require a comprehensive parking and traffic impact study before any approval is granted.
2. Mandate a reduction in the number of units and a substantial increase in on-site guest and overflow parking beyond the state minimum.
3. Give full weight to the concerns of current residents when evaluating whether this development is appropriate for this location.

I appreciate the Board's time and its commitment to fair and thorough review of matters that directly affect our community. I trust that these concerns will be reflected in the Board's deliberations.

Sincerely,  
Rachel W.

## Edwin Arreola

---

**From:** Dave Evans <dgriffinevans@gmail.com>  
**Sent:** Monday, May 11, 2026 3:44 PM  
**To:** Edwin Arreola  
**Cc:** Lisa Evans  
**Subject:** Traffic on Fairview Ave and the new development at 514

CAUTION: This email originated from outside your organization. Exercise caution when opening attachments or clicking links, especially from unknown senders.

Dear Mr. Arreola,

Please share the following message with Planning Commission members.

With respect to the proposed development at 514 Fairview Ave, I want to share my concerns about the impact on traffic. At the April 28 meeting, the city engineer indicated that the impact on traffic would be minimal. Such an assessment seems naïve at best considering two new multi-unit developments on La Cadena Ave, just around the corner from 514 Fairview Ave. The traffic on the 500-block of Fairview Ave is already perilous during parts of the day because drivers use it to avoid the traffic light at Baldwin and Huntington. Moreover, street parking on the block is often full, which blocks visibility for cars exiting driveways. The new development will only exacerbate these problems.

Regardless of whether the new project moves forward, I would ask the city to consider speed bumps (or some mechanism to slow traffic) on the 500-block of Fairview Ave and, at the very least, prohibiting street parking (i.e., using red curbs) for at least one car-length on each side of current driveways. In addition, adding a driveway to the Arcadia side of the new development would reduce street entry to the Fairview side. Without some effort to improve visibility, control speed, and/or cut down traffic from the new development, the likelihood of serious accidents will only increase on the 500 block of Fairview Ave. Sincerely,  
Dave Evans

# Attachment No. 7

## Architectural Plans



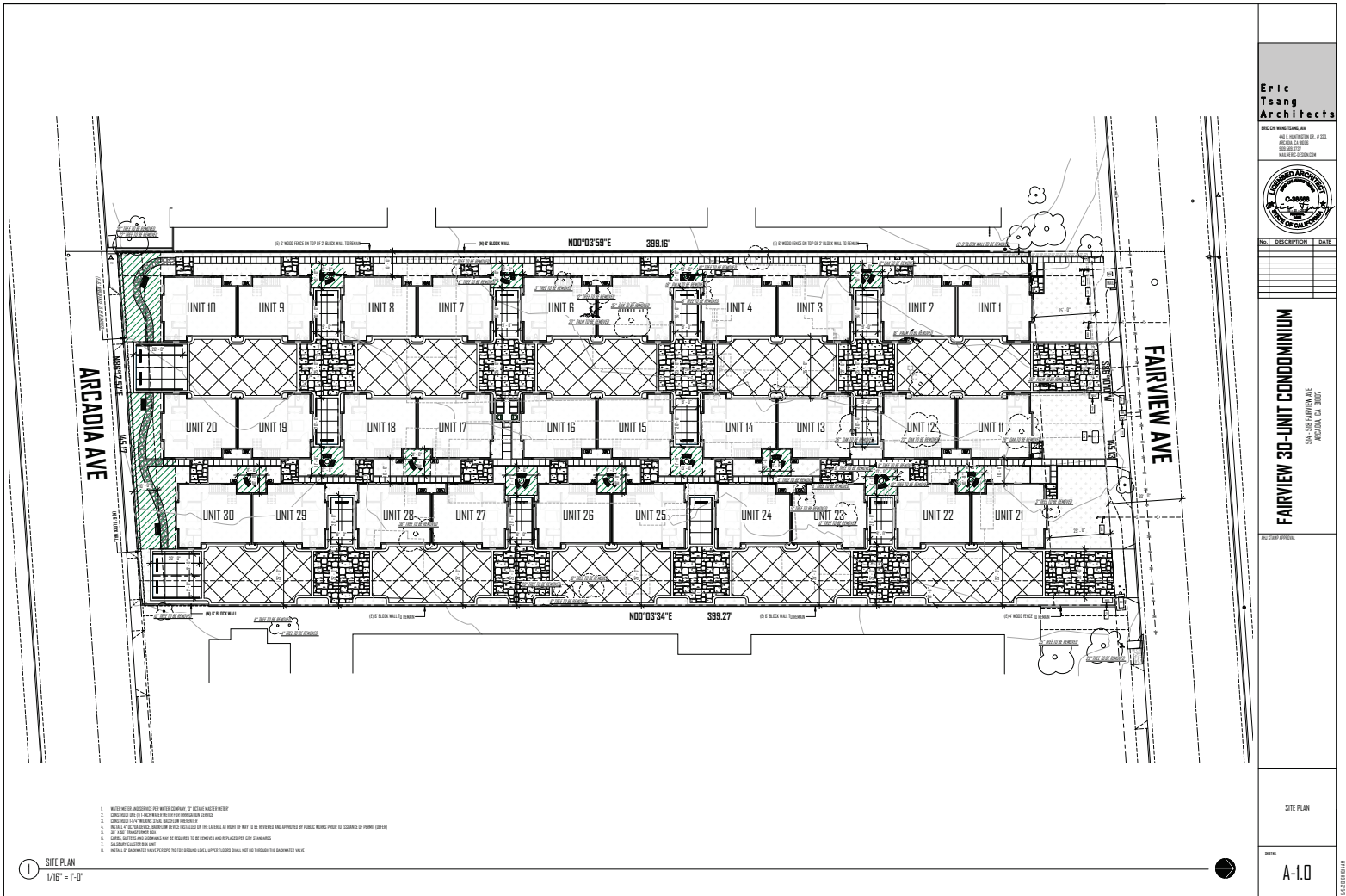

**Eric Tsang Architects**

1000 CHINESE TOWN BLVD  
 SUITE 200  
 SAN FRANCISCO, CA 94102  
 TEL: 415.774.8888  
 WWW.ERICTSANG.COM



NO.	DESCRIPTION	DATE

**FAIRVIEW 30-UNIT CONDOMINIUM**  
 300 S. FAIRVIEW AVE  
 SACRAMENTO, CA 95817

ARCHITECT

SITE PLAN

DATE: **A-1.0**

1. WATER MAIN AND SERVICE ARE UNDER CONTRACT. TO VERIFY WATER METER.
2. CONTRACTOR TO VERIFY ALL RECORDS AND RECORDS FOR UTILITIES.
3. CONTRACTOR TO VERIFY ALL RECORDS AND RECORDS FOR UTILITIES.
4. VERIFY ALL RECORDS AND RECORDS FOR UTILITIES.
5. VERIFY ALL RECORDS AND RECORDS FOR UTILITIES.
6. VERIFY ALL RECORDS AND RECORDS FOR UTILITIES.
7. VERIFY ALL RECORDS AND RECORDS FOR UTILITIES.
8. VERIFY ALL RECORDS AND RECORDS FOR UTILITIES.
9. VERIFY ALL RECORDS AND RECORDS FOR UTILITIES.
10. VERIFY ALL RECORDS AND RECORDS FOR UTILITIES.

Eric  
Tsang  
Architects

REG. NO. 32446  
 REG. DATE 10/11/2005  
 REG. EXPIRES 10/11/2011



NO.	DESCRIPTION	DATE

**FAIRVIEW 30-JUNIT CONDOMINIUM**  
 5811 - CORDONA AVE  
 IRVINE, CA 92717

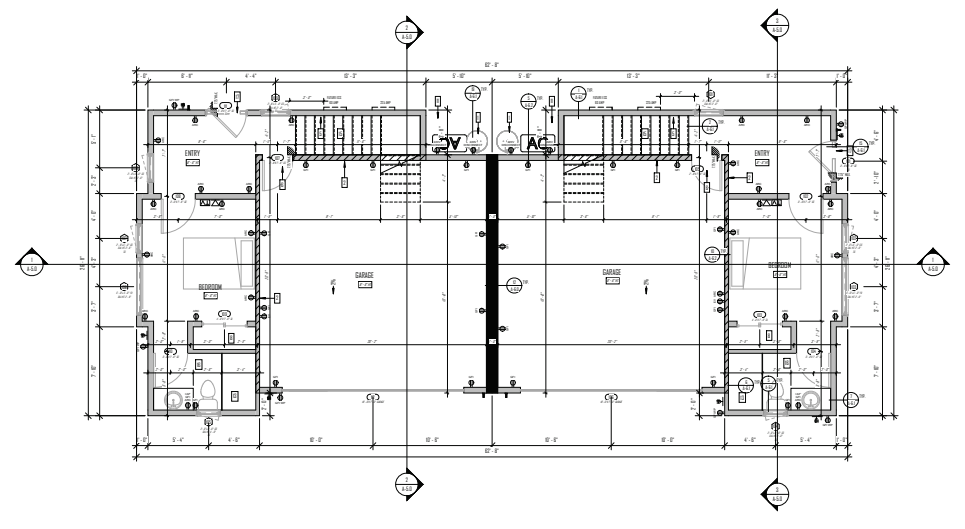

**1st FLOOR CONSTRUCTION PLAN**  
 1/4" = 1'-0"

- ### FLOOR PLAN NOTES
- THE WORK SHOWN AND NOTED IS IN ACCORDANCE WITH THE MOST RECENT REVISIONS TO THE SET OF CONSTRUCTION DOCUMENTS.
  - FOR ALL ROOMS, SEE ARCHITECTURAL SPECIFICATIONS FOR FINISHES.
  - CONCRETE
  - WALLS
  - WORKMANSHIP AND MATERIALS SHALL BE AS SPECIFIED IN THE ARCHITECTURAL SPECIFICATIONS AND RECORD DRAWINGS UNLESS OTHERWISE NOTED.
  - ALL CONCRETE SHALL BE CAST AND CURED ACCORDING TO THE ARCHITECTURAL SPECIFICATIONS AND RECORD DRAWINGS UNLESS OTHERWISE NOTED.
  - CONCRETE SHALL BE CAST AND CURED ACCORDING TO THE ARCHITECTURAL SPECIFICATIONS AND RECORD DRAWINGS UNLESS OTHERWISE NOTED.
  - CONCRETE SHALL BE CAST AND CURED ACCORDING TO THE ARCHITECTURAL SPECIFICATIONS AND RECORD DRAWINGS UNLESS OTHERWISE NOTED.
  - CONCRETE SHALL BE CAST AND CURED ACCORDING TO THE ARCHITECTURAL SPECIFICATIONS AND RECORD DRAWINGS UNLESS OTHERWISE NOTED.
  - CONCRETE SHALL BE CAST AND CURED ACCORDING TO THE ARCHITECTURAL SPECIFICATIONS AND RECORD DRAWINGS UNLESS OTHERWISE NOTED.
  - CONCRETE SHALL BE CAST AND CURED ACCORDING TO THE ARCHITECTURAL SPECIFICATIONS AND RECORD DRAWINGS UNLESS OTHERWISE NOTED.
  - CONCRETE SHALL BE CAST AND CURED ACCORDING TO THE ARCHITECTURAL SPECIFICATIONS AND RECORD DRAWINGS UNLESS OTHERWISE NOTED.
  - CONCRETE SHALL BE CAST AND CURED ACCORDING TO THE ARCHITECTURAL SPECIFICATIONS AND RECORD DRAWINGS UNLESS OTHERWISE NOTED.
  - CONCRETE SHALL BE CAST AND CURED ACCORDING TO THE ARCHITECTURAL SPECIFICATIONS AND RECORD DRAWINGS UNLESS OTHERWISE NOTED.
  - CONCRETE SHALL BE CAST AND CURED ACCORDING TO THE ARCHITECTURAL SPECIFICATIONS AND RECORD DRAWINGS UNLESS OTHERWISE NOTED.

- ### FLOOR PLAN LEGEND
- 1. CONCRETE FLOOR
  - 2. CONCRETE FLOOR WITH FINISH
  - 3. CONCRETE FLOOR WITH FINISH AND PAINT
  - 4. CONCRETE FLOOR WITH FINISH AND PAINT AND CARPET
  - 5. CONCRETE FLOOR WITH FINISH AND PAINT AND CARPET AND TILE
  - 6. CONCRETE FLOOR WITH FINISH AND PAINT AND CARPET AND TILE AND GYM
  - 7. CONCRETE FLOOR WITH FINISH AND PAINT AND CARPET AND TILE AND GYM AND STAIR
  - 8. CONCRETE FLOOR WITH FINISH AND PAINT AND CARPET AND TILE AND GYM AND STAIR AND BALCONY
  - 9. CONCRETE FLOOR WITH FINISH AND PAINT AND CARPET AND TILE AND GYM AND STAIR AND BALCONY AND GARAGE
  - 10. CONCRETE FLOOR WITH FINISH AND PAINT AND CARPET AND TILE AND GYM AND STAIR AND BALCONY AND GARAGE AND LAUNDRY
  - 11. CONCRETE FLOOR WITH FINISH AND PAINT AND CARPET AND TILE AND GYM AND STAIR AND BALCONY AND GARAGE AND LAUNDRY AND MECHANICAL
  - 12. CONCRETE FLOOR WITH FINISH AND PAINT AND CARPET AND TILE AND GYM AND STAIR AND BALCONY AND GARAGE AND LAUNDRY AND MECHANICAL AND ELECTRICAL
  - 13. CONCRETE FLOOR WITH FINISH AND PAINT AND CARPET AND TILE AND GYM AND STAIR AND BALCONY AND GARAGE AND LAUNDRY AND MECHANICAL AND ELECTRICAL AND PLUMBING
  - 14. CONCRETE FLOOR WITH FINISH AND PAINT AND CARPET AND TILE AND GYM AND STAIR AND BALCONY AND GARAGE AND LAUNDRY AND MECHANICAL AND ELECTRICAL AND PLUMBING AND FIRE PROTECTION
  - 15. CONCRETE FLOOR WITH FINISH AND PAINT AND CARPET AND TILE AND GYM AND STAIR AND BALCONY AND GARAGE AND LAUNDRY AND MECHANICAL AND ELECTRICAL AND PLUMBING AND FIRE PROTECTION AND SAFETY

### ABBREVIATIONS

SYM.	DESCRIPTION
CL	COLUMN
WC	WALL CENTERLINE
WC	WALL CENTERLINE
WC	WALL CENTERLINE
WC	WALL CENTERLINE
WC	WALL CENTERLINE
WC	WALL CENTERLINE
WC	WALL CENTERLINE
WC	WALL CENTERLINE
WC	WALL CENTERLINE

### WINDOW SCHEDULE

NO.	SYMBOL	FINISH	TYPE	SIZE (H x W)	FINISH	TYPE	SIZE (H x W)
1	W1	GLASS	1/2"	6'-0" x 8'-0"	GLASS	1/2"	6'-0" x 8'-0"
2	W2	GLASS	1/2"	4'-0" x 6'-0"	GLASS	1/2"	4'-0" x 6'-0"
3	W3	GLASS	1/2"	6'-0" x 4'-0"	GLASS	1/2"	6'-0" x 4'-0"
4	W4	GLASS	1/2"	8'-0" x 4'-0"	GLASS	1/2"	8'-0" x 4'-0"
5	W5	GLASS	1/2"	4'-0" x 8'-0"	GLASS	1/2"	4'-0" x 8'-0"

### DOOR SCHEDULE

NO.	SYMBOL	FINISH	TYPE	SIZE (H x W)	FINISH	TYPE	SIZE (H x W)
1	D1	GLASS	1/2"	6'-8" x 2'-8"	GLASS	1/2"	6'-8" x 2'-8"
2	D2	GLASS	1/2"	6'-8" x 2'-8"	GLASS	1/2"	6'-8" x 2'-8"
3	D3	GLASS	1/2"	6'-8" x 2'-8"	GLASS	1/2"	6'-8" x 2'-8"
4	D4	GLASS	1/2"	6'-8" x 2'-8"	GLASS	1/2"	6'-8" x 2'-8"
5	D5	GLASS	1/2"	6'-8" x 2'-8"	GLASS	1/2"	6'-8" x 2'-8"

### FLOOR PLAN KEYNOTE

1. ALL FINISHES SHALL BE AS SPECIFIED IN THE ARCHITECTURAL SPECIFICATIONS.
2. ALL WALLS SHALL BE CONCRETE UNLESS OTHERWISE NOTED.
3. ALL FLOORS SHALL BE CONCRETE UNLESS OTHERWISE NOTED.
4. ALL CEILING SHALL BE CONCRETE UNLESS OTHERWISE NOTED.
5. ALL MOLDINGS SHALL BE AS SPECIFIED IN THE ARCHITECTURAL SPECIFICATIONS.
6. ALL LIGHT FIXTURES SHALL BE AS SPECIFIED IN THE ARCHITECTURAL SPECIFICATIONS.
7. ALL MECHANICAL AND ELECTRICAL SHALL BE AS SPECIFIED IN THE ARCHITECTURAL SPECIFICATIONS.
8. ALL PLUMBING SHALL BE AS SPECIFIED IN THE ARCHITECTURAL SPECIFICATIONS.
9. ALL SAFETY SHALL BE AS SPECIFIED IN THE ARCHITECTURAL SPECIFICATIONS.
10. ALL BALCONY SHALL BE AS SPECIFIED IN THE ARCHITECTURAL SPECIFICATIONS.
11. ALL GARAGE SHALL BE AS SPECIFIED IN THE ARCHITECTURAL SPECIFICATIONS.
12. ALL LAUNDRY SHALL BE AS SPECIFIED IN THE ARCHITECTURAL SPECIFICATIONS.
13. ALL MECHANICAL SHALL BE AS SPECIFIED IN THE ARCHITECTURAL SPECIFICATIONS.
14. ALL ELECTRICAL SHALL BE AS SPECIFIED IN THE ARCHITECTURAL SPECIFICATIONS.
15. ALL PLUMBING SHALL BE AS SPECIFIED IN THE ARCHITECTURAL SPECIFICATIONS.

### FLOOR PLAN KEYNOTE

1. THE WORK SHOWN AND NOTED IS IN ACCORDANCE WITH THE MOST RECENT REVISIONS TO THE SET OF CONSTRUCTION DOCUMENTS.
2. ALL FINISHES SHALL BE AS SPECIFIED IN THE ARCHITECTURAL SPECIFICATIONS.
3. ALL WALLS SHALL BE CONCRETE UNLESS OTHERWISE NOTED.
4. ALL FLOORS SHALL BE CONCRETE UNLESS OTHERWISE NOTED.
5. ALL CEILING SHALL BE CONCRETE UNLESS OTHERWISE NOTED.
6. ALL MOLDINGS SHALL BE AS SPECIFIED IN THE ARCHITECTURAL SPECIFICATIONS.
7. ALL LIGHT FIXTURES SHALL BE AS SPECIFIED IN THE ARCHITECTURAL SPECIFICATIONS.
8. ALL MECHANICAL AND ELECTRICAL SHALL BE AS SPECIFIED IN THE ARCHITECTURAL SPECIFICATIONS.
9. ALL PLUMBING SHALL BE AS SPECIFIED IN THE ARCHITECTURAL SPECIFICATIONS.
10. ALL SAFETY SHALL BE AS SPECIFIED IN THE ARCHITECTURAL SPECIFICATIONS.
11. ALL BALCONY SHALL BE AS SPECIFIED IN THE ARCHITECTURAL SPECIFICATIONS.
12. ALL GARAGE SHALL BE AS SPECIFIED IN THE ARCHITECTURAL SPECIFICATIONS.
13. ALL LAUNDRY SHALL BE AS SPECIFIED IN THE ARCHITECTURAL SPECIFICATIONS.
14. ALL MECHANICAL SHALL BE AS SPECIFIED IN THE ARCHITECTURAL SPECIFICATIONS.
15. ALL ELECTRICAL SHALL BE AS SPECIFIED IN THE ARCHITECTURAL SPECIFICATIONS.
16. ALL PLUMBING SHALL BE AS SPECIFIED IN THE ARCHITECTURAL SPECIFICATIONS.

1st FLOOR CONSTRUCTION PLAN

A-2.0

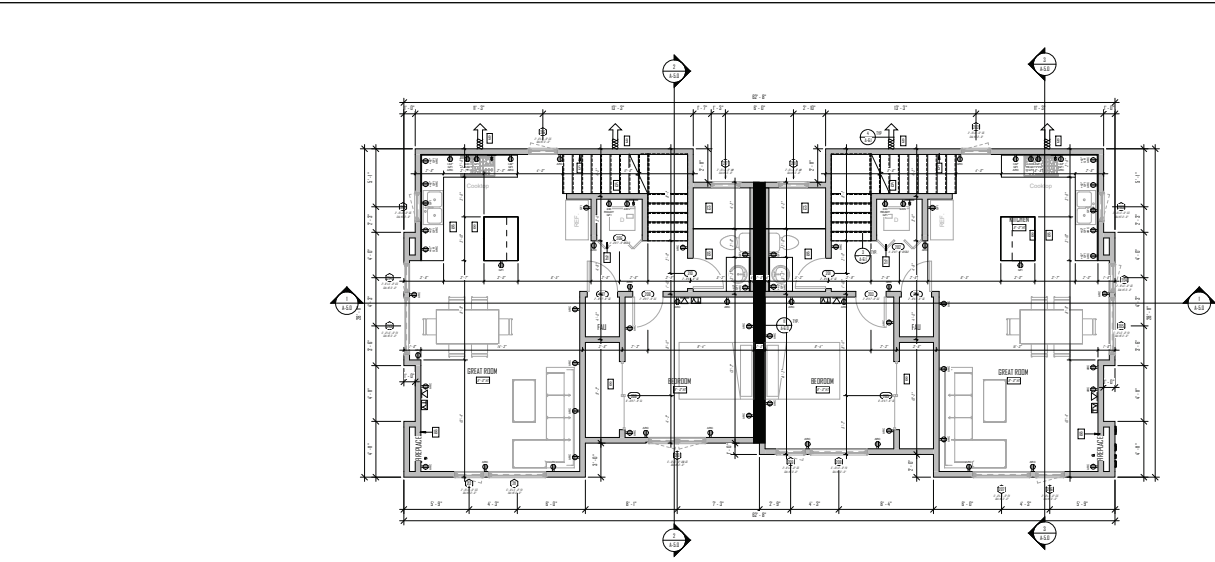

2ND FLOOR CONSTRUCTION PLAN  
1/4" = 1'-0"

ABBREVIATIONS	WINDOW SCHEDULE	DOOR SCHEDULE	FLOOR PLAN KEYNOTE	FLOOR PLAN KEYNOTE																																																																																																																																																																																																																																																																																																																																																																																				
<p><b>ABBREVIATIONS</b></p> <ul style="list-style-type: none"> <li>AW WINDOW</li> <li>CLF CLOSET</li> <li>CLD CLOSET</li> <li>CLB CLOSET</li> <li>CLT CLOSET</li> <li>CLM CLOSET</li> <li>CLN CLOSET</li> <li>CLX CLOSET</li> <li>CLY CLOSET</li> <li>CLZ CLOSET</li> <li>CLAA CLOSET</li> <li>CLAB CLOSET</li> <li>CLAC CLOSET</li> <li>CLAD CLOSET</li> <li>CLAE CLOSET</li> <li>CLAF CLOSET</li> <li>CLAG CLOSET</li> <li>CLAH CLOSET</li> <li>CLAI CLOSET</li> <li>CLAJ CLOSET</li> <li>CLAK CLOSET</li> <li>CLAL CLOSET</li> <li>CLAM CLOSET</li> <li>CLAN CLOSET</li> <li>CLAO CLOSET</li> <li>CLAP CLOSET</li> <li>CLAQ CLOSET</li> <li>CLAR CLOSET</li> <li>CLAS CLOSET</li> <li>CLAT CLOSET</li> <li>CLAU CLOSET</li> <li>CLAV CLOSET</li> <li>CLAW CLOSET</li> <li>CLAX CLOSET</li> <li>CLAY CLOSET</li> <li>CLAZ CLOSET</li> <li>CLAA CLOSET</li> <li>CLAB CLOSET</li> <li>CLAC CLOSET</li> <li>CLAD CLOSET</li> <li>CLAE CLOSET</li> <li>CLAF CLOSET</li> <li>CLAG CLOSET</li> <li>CLAH CLOSET</li> <li>CLAI CLOSET</li> <li>CLAJ CLOSET</li> <li>CLAK CLOSET</li> <li>CLAL CLOSET</li> <li>CLAM CLOSET</li> <li>CLAN CLOSET</li> <li>CLAO CLOSET</li> <li>CLAP CLOSET</li> <li>CLAQ CLOSET</li> <li>CLAR CLOSET</li> <li>CLAS CLOSET</li> <li>CLAT CLOSET</li> <li>CLAU CLOSET</li> <li>CLAV CLOSET</li> <li>CLAW CLOSET</li> <li>CLAX CLOSET</li> <li>CLAY CLOSET</li> <li>CLAZ CLOSET</li> </ul>	<p><b>WINDOW SCHEDULE</b></p> <table border="1"> <tr><th>NO.</th><th>TYPE</th><th>FINISH</th><th>GLASS</th><th>OPERATION</th><th>SCREEN</th></tr> <tr><td>W1</td><td>W1</td><td>W1</td><td>W1</td><td>W1</td><td>W1</td></tr> <tr><td>W2</td><td>W2</td><td>W2</td><td>W2</td><td>W2</td><td>W2</td></tr> <tr><td>W3</td><td>W3</td><td>W3</td><td>W3</td><td>W3</td><td>W3</td></tr> <tr><td>W4</td><td>W4</td><td>W4</td><td>W4</td><td>W4</td><td>W4</td></tr> <tr><td>W5</td><td>W5</td><td>W5</td><td>W5</td><td>W5</td><td>W5</td></tr> <tr><td>W6</td><td>W6</td><td>W6</td><td>W6</td><td>W6</td><td>W6</td></tr> <tr><td>W7</td><td>W7</td><td>W7</td><td>W7</td><td>W7</td><td>W7</td></tr> <tr><td>W8</td><td>W8</td><td>W8</td><td>W8</td><td>W8</td><td>W8</td></tr> <tr><td>W9</td><td>W9</td><td>W9</td><td>W9</td><td>W9</td><td>W9</td></tr> <tr><td>W10</td><td>W10</td><td>W10</td><td>W10</td><td>W10</td><td>W10</td></tr> <tr><td>W11</td><td>W11</td><td>W11</td><td>W11</td><td>W11</td><td>W11</td></tr> <tr><td>W12</td><td>W12</td><td>W12</td><td>W12</td><td>W12</td><td>W12</td></tr> <tr><td>W13</td><td>W13</td><td>W13</td><td>W13</td><td>W13</td><td>W13</td></tr> <tr><td>W14</td><td>W14</td><td>W14</td><td>W14</td><td>W14</td><td>W14</td></tr> <tr><td>W15</td><td>W15</td><td>W15</td><td>W15</td><td>W15</td><td>W15</td></tr> <tr><td>W16</td><td>W16</td><td>W16</td><td>W16</td><td>W16</td><td>W16</td></tr> <tr><td>W17</td><td>W17</td><td>W17</td><td>W17</td><td>W17</td><td>W17</td></tr> <tr><td>W18</td><td>W18</td><td>W18</td><td>W18</td><td>W18</td><td>W18</td></tr> <tr><td>W19</td><td>W19</td><td>W19</td><td>W19</td><td>W19</td><td>W19</td></tr> <tr><td>W20</td><td>W20</td><td>W20</td><td>W20</td><td>W20</td><td>W20</td></tr> <tr><td>W21</td><td>W21</td><td>W21</td><td>W21</td><td>W21</td><td>W21</td></tr> <tr><td>W22</td><td>W22</td><td>W22</td><td>W22</td><td>W22</td><td>W22</td></tr> <tr><td>W23</td><td>W23</td><td>W23</td><td>W23</td><td>W23</td><td>W23</td></tr> <tr><td>W24</td><td>W24</td><td>W24</td><td>W24</td><td>W24</td><td>W24</td></tr> <tr><td>W25</td><td>W25</td><td>W25</td><td>W25</td><td>W25</td><td>W25</td></tr> <tr><td>W26</td><td>W26</td><td>W26</td><td>W26</td><td>W26</td><td>W26</td></tr> <tr><td>W27</td><td>W27</td><td>W27</td><td>W27</td><td>W27</td><td>W27</td></tr> <tr><td>W28</td><td>W28</td><td>W28</td><td>W28</td><td>W28</td><td>W28</td></tr> <tr><td>W29</td><td>W29</td><td>W29</td><td>W29</td><td>W29</td><td>W29</td></tr> <tr><td>W30</td><td>W30</td><td>W30</td><td>W30</td><td>W30</td><td>W30</td></tr> </table>	NO.	TYPE	FINISH	GLASS	OPERATION	SCREEN	W1	W1	W1	W1	W1	W1	W2	W2	W2	W2	W2	W2	W3	W3	W3	W3	W3	W3	W4	W4	W4	W4	W4	W4	W5	W5	W5	W5	W5	W5	W6	W6	W6	W6	W6	W6	W7	W7	W7	W7	W7	W7	W8	W8	W8	W8	W8	W8	W9	W9	W9	W9	W9	W9	W10	W10	W10	W10	W10	W10	W11	W11	W11	W11	W11	W11	W12	W12	W12	W12	W12	W12	W13	W13	W13	W13	W13	W13	W14	W14	W14	W14	W14	W14	W15	W15	W15	W15	W15	W15	W16	W16	W16	W16	W16	W16	W17	W17	W17	W17	W17	W17	W18	W18	W18	W18	W18	W18	W19	W19	W19	W19	W19	W19	W20	W20	W20	W20	W20	W20	W21	W21	W21	W21	W21	W21	W22	W22	W22	W22	W22	W22	W23	W23	W23	W23	W23	W23	W24	W24	W24	W24	W24	W24	W25	W25	W25	W25	W25	W25	W26	W26	W26	W26	W26	W26	W27	W27	W27	W27	W27	W27	W28	W28	W28	W28	W28	W28	W29	W29	W29	W29	W29	W29	W30	W30	W30	W30	W30	W30	<p><b>DOOR SCHEDULE</b></p> <table border="1"> <tr><th>NO.</th><th>TYPE</th><th>FINISH</th><th>GLASS</th><th>OPERATION</th><th>SCREEN</th></tr> <tr><td>D1</td><td>D1</td><td>D1</td><td>D1</td><td>D1</td><td>D1</td></tr> <tr><td>D2</td><td>D2</td><td>D2</td><td>D2</td><td>D2</td><td>D2</td></tr> <tr><td>D3</td><td>D3</td><td>D3</td><td>D3</td><td>D3</td><td>D3</td></tr> <tr><td>D4</td><td>D4</td><td>D4</td><td>D4</td><td>D4</td><td>D4</td></tr> <tr><td>D5</td><td>D5</td><td>D5</td><td>D5</td><td>D5</td><td>D5</td></tr> <tr><td>D6</td><td>D6</td><td>D6</td><td>D6</td><td>D6</td><td>D6</td></tr> <tr><td>D7</td><td>D7</td><td>D7</td><td>D7</td><td>D7</td><td>D7</td></tr> <tr><td>D8</td><td>D8</td><td>D8</td><td>D8</td><td>D8</td><td>D8</td></tr> <tr><td>D9</td><td>D9</td><td>D9</td><td>D9</td><td>D9</td><td>D9</td></tr> <tr><td>D10</td><td>D10</td><td>D10</td><td>D10</td><td>D10</td><td>D10</td></tr> <tr><td>D11</td><td>D11</td><td>D11</td><td>D11</td><td>D11</td><td>D11</td></tr> <tr><td>D12</td><td>D12</td><td>D12</td><td>D12</td><td>D12</td><td>D12</td></tr> <tr><td>D13</td><td>D13</td><td>D13</td><td>D13</td><td>D13</td><td>D13</td></tr> <tr><td>D14</td><td>D14</td><td>D14</td><td>D14</td><td>D14</td><td>D14</td></tr> <tr><td>D15</td><td>D15</td><td>D15</td><td>D15</td><td>D15</td><td>D15</td></tr> <tr><td>D16</td><td>D16</td><td>D16</td><td>D16</td><td>D16</td><td>D16</td></tr> <tr><td>D17</td><td>D17</td><td>D17</td><td>D17</td><td>D17</td><td>D17</td></tr> <tr><td>D18</td><td>D18</td><td>D18</td><td>D18</td><td>D18</td><td>D18</td></tr> <tr><td>D19</td><td>D19</td><td>D19</td><td>D19</td><td>D19</td><td>D19</td></tr> <tr><td>D20</td><td>D20</td><td>D20</td><td>D20</td><td>D20</td><td>D20</td></tr> <tr><td>D21</td><td>D21</td><td>D21</td><td>D21</td><td>D21</td><td>D21</td></tr> <tr><td>D22</td><td>D22</td><td>D22</td><td>D22</td><td>D22</td><td>D22</td></tr> <tr><td>D23</td><td>D23</td><td>D23</td><td>D23</td><td>D23</td><td>D23</td></tr> <tr><td>D24</td><td>D24</td><td>D24</td><td>D24</td><td>D24</td><td>D24</td></tr> <tr><td>D25</td><td>D25</td><td>D25</td><td>D25</td><td>D25</td><td>D25</td></tr> <tr><td>D26</td><td>D26</td><td>D26</td><td>D26</td><td>D26</td><td>D26</td></tr> <tr><td>D27</td><td>D27</td><td>D27</td><td>D27</td><td>D27</td><td>D27</td></tr> <tr><td>D28</td><td>D28</td><td>D28</td><td>D28</td><td>D28</td><td>D28</td></tr> <tr><td>D29</td><td>D29</td><td>D29</td><td>D29</td><td>D29</td><td>D29</td></tr> <tr><td>D30</td><td>D30</td><td>D30</td><td>D30</td><td>D30</td><td>D30</td></tr> </table>	NO.	TYPE	FINISH	GLASS	OPERATION	SCREEN	D1	D1	D1	D1	D1	D1	D2	D2	D2	D2	D2	D2	D3	D3	D3	D3	D3	D3	D4	D4	D4	D4	D4	D4	D5	D5	D5	D5	D5	D5	D6	D6	D6	D6	D6	D6	D7	D7	D7	D7	D7	D7	D8	D8	D8	D8	D8	D8	D9	D9	D9	D9	D9	D9	D10	D10	D10	D10	D10	D10	D11	D11	D11	D11	D11	D11	D12	D12	D12	D12	D12	D12	D13	D13	D13	D13	D13	D13	D14	D14	D14	D14	D14	D14	D15	D15	D15	D15	D15	D15	D16	D16	D16	D16	D16	D16	D17	D17	D17	D17	D17	D17	D18	D18	D18	D18	D18	D18	D19	D19	D19	D19	D19	D19	D20	D20	D20	D20	D20	D20	D21	D21	D21	D21	D21	D21	D22	D22	D22	D22	D22	D22	D23	D23	D23	D23	D23	D23	D24	D24	D24	D24	D24	D24	D25	D25	D25	D25	D25	D25	D26	D26	D26	D26	D26	D26	D27	D27	D27	D27	D27	D27	D28	D28	D28	D28	D28	D28	D29	D29	D29	D29	D29	D29	D30	D30	D30	D30	D30	D30	<p><b>FLOOR PLAN KEYNOTE</b></p> <p>1. ALL FINISHES SHALL BE AS SHOWN UNLESS OTHERWISE NOTED.</p> <p>2. ALL FINISHES SHALL BE AS SHOWN UNLESS OTHERWISE NOTED.</p> <p>3. ALL FINISHES SHALL BE AS SHOWN UNLESS OTHERWISE NOTED.</p> <p>4. ALL FINISHES SHALL BE AS SHOWN UNLESS OTHERWISE NOTED.</p> <p>5. ALL FINISHES SHALL BE AS SHOWN UNLESS OTHERWISE NOTED.</p> <p>6. ALL FINISHES SHALL BE AS SHOWN UNLESS OTHERWISE NOTED.</p> <p>7. ALL FINISHES SHALL BE AS SHOWN UNLESS OTHERWISE NOTED.</p> <p>8. ALL FINISHES SHALL BE AS SHOWN UNLESS OTHERWISE NOTED.</p> <p>9. ALL FINISHES SHALL BE AS SHOWN UNLESS OTHERWISE NOTED.</p> <p>10. ALL FINISHES SHALL BE AS SHOWN UNLESS OTHERWISE NOTED.</p> <p>11. ALL FINISHES SHALL BE AS SHOWN UNLESS OTHERWISE NOTED.</p> <p>12. ALL FINISHES SHALL BE AS SHOWN UNLESS OTHERWISE NOTED.</p> <p>13. ALL FINISHES SHALL BE AS SHOWN UNLESS OTHERWISE NOTED.</p> <p>14. ALL FINISHES SHALL BE AS SHOWN UNLESS OTHERWISE NOTED.</p> <p>15. ALL FINISHES SHALL BE AS SHOWN UNLESS OTHERWISE NOTED.</p> <p>16. ALL FINISHES SHALL BE AS SHOWN UNLESS OTHERWISE NOTED.</p> <p>17. ALL FINISHES SHALL BE AS SHOWN UNLESS OTHERWISE NOTED.</p> <p>18. ALL FINISHES SHALL BE AS SHOWN UNLESS OTHERWISE NOTED.</p> <p>19. ALL FINISHES SHALL BE AS SHOWN UNLESS OTHERWISE NOTED.</p> <p>20. ALL FINISHES SHALL BE AS SHOWN UNLESS OTHERWISE NOTED.</p> <p>21. ALL FINISHES SHALL BE AS SHOWN UNLESS OTHERWISE NOTED.</p> <p>22. ALL FINISHES SHALL BE AS SHOWN UNLESS OTHERWISE NOTED.</p> <p>23. ALL FINISHES SHALL BE AS SHOWN UNLESS OTHERWISE NOTED.</p> <p>24. ALL FINISHES SHALL BE AS SHOWN UNLESS OTHERWISE NOTED.</p> <p>25. ALL FINISHES SHALL BE AS SHOWN UNLESS OTHERWISE NOTED.</p> <p>26. ALL FINISHES SHALL BE AS SHOWN UNLESS OTHERWISE NOTED.</p> <p>27. ALL FINISHES SHALL BE AS SHOWN UNLESS OTHERWISE NOTED.</p> <p>28. ALL FINISHES SHALL BE AS SHOWN UNLESS OTHERWISE NOTED.</p> <p>29. ALL FINISHES SHALL BE AS SHOWN UNLESS OTHERWISE NOTED.</p> <p>30. ALL FINISHES SHALL BE AS SHOWN UNLESS OTHERWISE NOTED.</p>	<p><b>FLOOR PLAN KEYNOTE</b></p> <p>1. ALL FINISHES SHALL BE AS SHOWN UNLESS OTHERWISE NOTED.</p> <p>2. ALL FINISHES SHALL BE AS SHOWN UNLESS OTHERWISE NOTED.</p> <p>3. ALL FINISHES SHALL BE AS SHOWN UNLESS OTHERWISE NOTED.</p> <p>4. ALL FINISHES SHALL BE AS SHOWN UNLESS OTHERWISE NOTED.</p> <p>5. ALL FINISHES SHALL BE AS SHOWN UNLESS OTHERWISE NOTED.</p> <p>6. ALL FINISHES SHALL BE AS SHOWN UNLESS OTHERWISE NOTED.</p> <p>7. ALL FINISHES SHALL BE AS SHOWN UNLESS OTHERWISE NOTED.</p> <p>8. ALL FINISHES SHALL BE AS SHOWN UNLESS OTHERWISE NOTED.</p> <p>9. ALL FINISHES SHALL BE AS SHOWN UNLESS OTHERWISE NOTED.</p> <p>10. ALL FINISHES SHALL BE AS SHOWN UNLESS OTHERWISE NOTED.</p> <p>11. ALL FINISHES SHALL BE AS SHOWN UNLESS OTHERWISE NOTED.</p> <p>12. ALL FINISHES SHALL BE AS SHOWN UNLESS OTHERWISE NOTED.</p> <p>13. ALL FINISHES SHALL BE AS SHOWN UNLESS OTHERWISE NOTED.</p> <p>14. ALL FINISHES SHALL BE AS SHOWN UNLESS OTHERWISE NOTED.</p> <p>15. ALL FINISHES SHALL BE AS SHOWN UNLESS OTHERWISE NOTED.</p> <p>16. ALL FINISHES SHALL BE AS SHOWN UNLESS OTHERWISE NOTED.</p> <p>17. ALL FINISHES SHALL BE AS SHOWN UNLESS OTHERWISE NOTED.</p> <p>18. ALL FINISHES SHALL BE AS SHOWN UNLESS OTHERWISE NOTED.</p> <p>19. ALL FINISHES SHALL BE AS SHOWN UNLESS OTHERWISE NOTED.</p> <p>20. ALL FINISHES SHALL BE AS SHOWN UNLESS OTHERWISE NOTED.</p> <p>21. ALL FINISHES SHALL BE AS SHOWN UNLESS OTHERWISE NOTED.</p> <p>22. ALL FINISHES SHALL BE AS SHOWN UNLESS OTHERWISE NOTED.</p> <p>23. ALL FINISHES SHALL BE AS SHOWN UNLESS OTHERWISE NOTED.</p> <p>24. ALL FINISHES SHALL BE AS SHOWN UNLESS OTHERWISE NOTED.</p> <p>25. ALL FINISHES SHALL BE AS SHOWN UNLESS OTHERWISE NOTED.</p> <p>26. ALL FINISHES SHALL BE AS SHOWN UNLESS OTHERWISE NOTED.</p> <p>27. ALL FINISHES SHALL BE AS SHOWN UNLESS OTHERWISE NOTED.</p> <p>28. ALL FINISHES SHALL BE AS SHOWN UNLESS OTHERWISE NOTED.</p> <p>29. ALL FINISHES SHALL BE AS SHOWN UNLESS OTHERWISE NOTED.</p> <p>30. ALL FINISHES SHALL BE AS SHOWN UNLESS OTHERWISE NOTED.</p>
NO.	TYPE	FINISH	GLASS	OPERATION	SCREEN																																																																																																																																																																																																																																																																																																																																																																																			
W1	W1	W1	W1	W1	W1																																																																																																																																																																																																																																																																																																																																																																																			
W2	W2	W2	W2	W2	W2																																																																																																																																																																																																																																																																																																																																																																																			
W3	W3	W3	W3	W3	W3																																																																																																																																																																																																																																																																																																																																																																																			
W4	W4	W4	W4	W4	W4																																																																																																																																																																																																																																																																																																																																																																																			
W5	W5	W5	W5	W5	W5																																																																																																																																																																																																																																																																																																																																																																																			
W6	W6	W6	W6	W6	W6																																																																																																																																																																																																																																																																																																																																																																																			
W7	W7	W7	W7	W7	W7																																																																																																																																																																																																																																																																																																																																																																																			
W8	W8	W8	W8	W8	W8																																																																																																																																																																																																																																																																																																																																																																																			
W9	W9	W9	W9	W9	W9																																																																																																																																																																																																																																																																																																																																																																																			
W10	W10	W10	W10	W10	W10																																																																																																																																																																																																																																																																																																																																																																																			
W11	W11	W11	W11	W11	W11																																																																																																																																																																																																																																																																																																																																																																																			
W12	W12	W12	W12	W12	W12																																																																																																																																																																																																																																																																																																																																																																																			
W13	W13	W13	W13	W13	W13																																																																																																																																																																																																																																																																																																																																																																																			
W14	W14	W14	W14	W14	W14																																																																																																																																																																																																																																																																																																																																																																																			
W15	W15	W15	W15	W15	W15																																																																																																																																																																																																																																																																																																																																																																																			
W16	W16	W16	W16	W16	W16																																																																																																																																																																																																																																																																																																																																																																																			
W17	W17	W17	W17	W17	W17																																																																																																																																																																																																																																																																																																																																																																																			
W18	W18	W18	W18	W18	W18																																																																																																																																																																																																																																																																																																																																																																																			
W19	W19	W19	W19	W19	W19																																																																																																																																																																																																																																																																																																																																																																																			
W20	W20	W20	W20	W20	W20																																																																																																																																																																																																																																																																																																																																																																																			
W21	W21	W21	W21	W21	W21																																																																																																																																																																																																																																																																																																																																																																																			
W22	W22	W22	W22	W22	W22																																																																																																																																																																																																																																																																																																																																																																																			
W23	W23	W23	W23	W23	W23																																																																																																																																																																																																																																																																																																																																																																																			
W24	W24	W24	W24	W24	W24																																																																																																																																																																																																																																																																																																																																																																																			
W25	W25	W25	W25	W25	W25																																																																																																																																																																																																																																																																																																																																																																																			
W26	W26	W26	W26	W26	W26																																																																																																																																																																																																																																																																																																																																																																																			
W27	W27	W27	W27	W27	W27																																																																																																																																																																																																																																																																																																																																																																																			
W28	W28	W28	W28	W28	W28																																																																																																																																																																																																																																																																																																																																																																																			
W29	W29	W29	W29	W29	W29																																																																																																																																																																																																																																																																																																																																																																																			
W30	W30	W30	W30	W30	W30																																																																																																																																																																																																																																																																																																																																																																																			
NO.	TYPE	FINISH	GLASS	OPERATION	SCREEN																																																																																																																																																																																																																																																																																																																																																																																			
D1	D1	D1	D1	D1	D1																																																																																																																																																																																																																																																																																																																																																																																			
D2	D2	D2	D2	D2	D2																																																																																																																																																																																																																																																																																																																																																																																			
D3	D3	D3	D3	D3	D3																																																																																																																																																																																																																																																																																																																																																																																			
D4	D4	D4	D4	D4	D4																																																																																																																																																																																																																																																																																																																																																																																			
D5	D5	D5	D5	D5	D5																																																																																																																																																																																																																																																																																																																																																																																			
D6	D6	D6	D6	D6	D6																																																																																																																																																																																																																																																																																																																																																																																			
D7	D7	D7	D7	D7	D7																																																																																																																																																																																																																																																																																																																																																																																			
D8	D8	D8	D8	D8	D8																																																																																																																																																																																																																																																																																																																																																																																			
D9	D9	D9	D9	D9	D9																																																																																																																																																																																																																																																																																																																																																																																			
D10	D10	D10	D10	D10	D10																																																																																																																																																																																																																																																																																																																																																																																			
D11	D11	D11	D11	D11	D11																																																																																																																																																																																																																																																																																																																																																																																			
D12	D12	D12	D12	D12	D12																																																																																																																																																																																																																																																																																																																																																																																			
D13	D13	D13	D13	D13	D13																																																																																																																																																																																																																																																																																																																																																																																			
D14	D14	D14	D14	D14	D14																																																																																																																																																																																																																																																																																																																																																																																			
D15	D15	D15	D15	D15	D15																																																																																																																																																																																																																																																																																																																																																																																			
D16	D16	D16	D16	D16	D16																																																																																																																																																																																																																																																																																																																																																																																			
D17	D17	D17	D17	D17	D17																																																																																																																																																																																																																																																																																																																																																																																			
D18	D18	D18	D18	D18	D18																																																																																																																																																																																																																																																																																																																																																																																			
D19	D19	D19	D19	D19	D19																																																																																																																																																																																																																																																																																																																																																																																			
D20	D20	D20	D20	D20	D20																																																																																																																																																																																																																																																																																																																																																																																			
D21	D21	D21	D21	D21	D21																																																																																																																																																																																																																																																																																																																																																																																			
D22	D22	D22	D22	D22	D22																																																																																																																																																																																																																																																																																																																																																																																			
D23	D23	D23	D23	D23	D23																																																																																																																																																																																																																																																																																																																																																																																			
D24	D24	D24	D24	D24	D24																																																																																																																																																																																																																																																																																																																																																																																			
D25	D25	D25	D25	D25	D25																																																																																																																																																																																																																																																																																																																																																																																			
D26	D26	D26	D26	D26	D26																																																																																																																																																																																																																																																																																																																																																																																			
D27	D27	D27	D27	D27	D27																																																																																																																																																																																																																																																																																																																																																																																			
D28	D28	D28	D28	D28	D28																																																																																																																																																																																																																																																																																																																																																																																			
D29	D29	D29	D29	D29	D29																																																																																																																																																																																																																																																																																																																																																																																			
D30	D30	D30	D30	D30	D30																																																																																																																																																																																																																																																																																																																																																																																			

**Eric Tsang Architects**  
 ARCHITECTS  
 1000 RIVER STREET, SUITE 100  
 SAN JOSE, CALIFORNIA 95128  
 TEL: 415.998.8888  
 WWW.ERICTSANG.COM

**FAIRVIEW 30-JOINT CONDOMINIUM**  
 301 - 302 BAYVIEW AVE  
 SAN JOSE, CA 95128

**2ND FLOOR CONSTRUCTION PLAN**

**A-2.1**

## 3RD FLOOR CONSTRUCTION PLAN 1/4" = 1'-0"

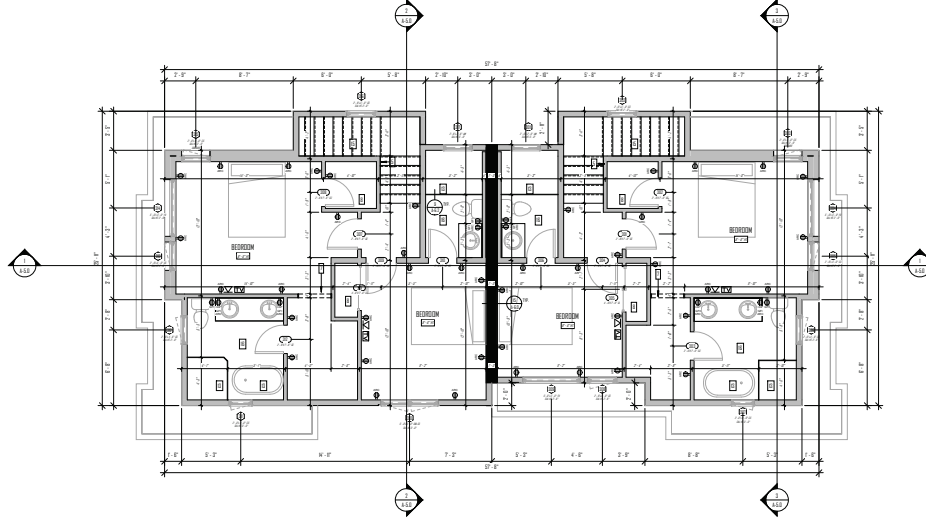

- ### FLOOR PLAN NOTES
1. THE WINDOW SCHEDULE IS BASED UPON WINDOW SIZES SHOWN IN THE UNIT VITAL PANEL INFORMATION HAS BEEN CHECKED FOR ALL TYPES OF WINDOW SIZES.
  2. WINDOW SCHEDULE IS FOR THE WINDOW SIZES SHOWN IN THE UNIT VITAL PANEL INFORMATION HAS BEEN CHECKED FOR ALL TYPES OF WINDOW SIZES.
  3. WINDOW SCHEDULE IS FOR THE WINDOW SIZES SHOWN IN THE UNIT VITAL PANEL INFORMATION HAS BEEN CHECKED FOR ALL TYPES OF WINDOW SIZES.
  4. WINDOW SCHEDULE IS FOR THE WINDOW SIZES SHOWN IN THE UNIT VITAL PANEL INFORMATION HAS BEEN CHECKED FOR ALL TYPES OF WINDOW SIZES.
  5. WINDOW SCHEDULE IS FOR THE WINDOW SIZES SHOWN IN THE UNIT VITAL PANEL INFORMATION HAS BEEN CHECKED FOR ALL TYPES OF WINDOW SIZES.
  6. WINDOW SCHEDULE IS FOR THE WINDOW SIZES SHOWN IN THE UNIT VITAL PANEL INFORMATION HAS BEEN CHECKED FOR ALL TYPES OF WINDOW SIZES.
  7. WINDOW SCHEDULE IS FOR THE WINDOW SIZES SHOWN IN THE UNIT VITAL PANEL INFORMATION HAS BEEN CHECKED FOR ALL TYPES OF WINDOW SIZES.
  8. WINDOW SCHEDULE IS FOR THE WINDOW SIZES SHOWN IN THE UNIT VITAL PANEL INFORMATION HAS BEEN CHECKED FOR ALL TYPES OF WINDOW SIZES.
  9. WINDOW SCHEDULE IS FOR THE WINDOW SIZES SHOWN IN THE UNIT VITAL PANEL INFORMATION HAS BEEN CHECKED FOR ALL TYPES OF WINDOW SIZES.
  10. WINDOW SCHEDULE IS FOR THE WINDOW SIZES SHOWN IN THE UNIT VITAL PANEL INFORMATION HAS BEEN CHECKED FOR ALL TYPES OF WINDOW SIZES.
  11. WINDOW SCHEDULE IS FOR THE WINDOW SIZES SHOWN IN THE UNIT VITAL PANEL INFORMATION HAS BEEN CHECKED FOR ALL TYPES OF WINDOW SIZES.
  12. WINDOW SCHEDULE IS FOR THE WINDOW SIZES SHOWN IN THE UNIT VITAL PANEL INFORMATION HAS BEEN CHECKED FOR ALL TYPES OF WINDOW SIZES.

- ### FLOOR PLAN LEGEND
- 1. WINDOW SCHEDULE
  - 2. DOOR SCHEDULE
  - 3. FLOOR PLAN KEYNOTE
  - 4. FLOOR PLAN KEYNOTE

SYMBOL	DESCRIPTION
BR	BEDROOM
BATH	BATHROOM
CL	CLOSET
CO	COMMON AREA
LI	LIVING AREA
LA	LANDSCAPE AREA
ST	STAIR
PL	POOL
SI	SITE

NO.	TYPE	W	H	FINISH	GLASS	OPERATION	MARKING
1	DOOR	3'-0"	6'-0"	SLIP	1/2"	SLIP	100
2	DOOR	3'-0"	6'-0"	SLIP	1/2"	SLIP	100
3	DOOR	3'-0"	6'-0"	SLIP	1/2"	SLIP	100
4	DOOR	3'-0"	6'-0"	SLIP	1/2"	SLIP	100
5	DOOR	3'-0"	6'-0"	SLIP	1/2"	SLIP	100
6	DOOR	3'-0"	6'-0"	SLIP	1/2"	SLIP	100
7	DOOR	3'-0"	6'-0"	SLIP	1/2"	SLIP	100
8	DOOR	3'-0"	6'-0"	SLIP	1/2"	SLIP	100
9	DOOR	3'-0"	6'-0"	SLIP	1/2"	SLIP	100
10	DOOR	3'-0"	6'-0"	SLIP	1/2"	SLIP	100
11	DOOR	3'-0"	6'-0"	SLIP	1/2"	SLIP	100
12	DOOR	3'-0"	6'-0"	SLIP	1/2"	SLIP	100

NO.	TYPE	W	H	FINISH	GLASS	OPERATION	MARKING
1	DOOR	3'-0"	6'-0"	SLIP	1/2"	SLIP	100
2	DOOR	3'-0"	6'-0"	SLIP	1/2"	SLIP	100
3	DOOR	3'-0"	6'-0"	SLIP	1/2"	SLIP	100
4	DOOR	3'-0"	6'-0"	SLIP	1/2"	SLIP	100
5	DOOR	3'-0"	6'-0"	SLIP	1/2"	SLIP	100
6	DOOR	3'-0"	6'-0"	SLIP	1/2"	SLIP	100
7	DOOR	3'-0"	6'-0"	SLIP	1/2"	SLIP	100
8	DOOR	3'-0"	6'-0"	SLIP	1/2"	SLIP	100
9	DOOR	3'-0"	6'-0"	SLIP	1/2"	SLIP	100
10	DOOR	3'-0"	6'-0"	SLIP	1/2"	SLIP	100
11	DOOR	3'-0"	6'-0"	SLIP	1/2"	SLIP	100
12	DOOR	3'-0"	6'-0"	SLIP	1/2"	SLIP	100

KEYNOTE	DESCRIPTION
K1	DOOR THRESHOLD TO BE INSTALLED AT THE BOTTOM OF THE DOOR FRAME.
K2	DOOR THRESHOLD TO BE INSTALLED AT THE BOTTOM OF THE DOOR FRAME.
K3	DOOR THRESHOLD TO BE INSTALLED AT THE BOTTOM OF THE DOOR FRAME.
K4	DOOR THRESHOLD TO BE INSTALLED AT THE BOTTOM OF THE DOOR FRAME.
K5	DOOR THRESHOLD TO BE INSTALLED AT THE BOTTOM OF THE DOOR FRAME.
K6	DOOR THRESHOLD TO BE INSTALLED AT THE BOTTOM OF THE DOOR FRAME.
K7	DOOR THRESHOLD TO BE INSTALLED AT THE BOTTOM OF THE DOOR FRAME.
K8	DOOR THRESHOLD TO BE INSTALLED AT THE BOTTOM OF THE DOOR FRAME.
K9	DOOR THRESHOLD TO BE INSTALLED AT THE BOTTOM OF THE DOOR FRAME.
K10	DOOR THRESHOLD TO BE INSTALLED AT THE BOTTOM OF THE DOOR FRAME.
K11	DOOR THRESHOLD TO BE INSTALLED AT THE BOTTOM OF THE DOOR FRAME.
K12	DOOR THRESHOLD TO BE INSTALLED AT THE BOTTOM OF THE DOOR FRAME.

- ### FLOOR PLAN KEYNOTE
1. WINDOW SCHEDULE
  2. DOOR SCHEDULE
  3. FLOOR PLAN KEYNOTE
  4. FLOOR PLAN KEYNOTE
  5. FLOOR PLAN KEYNOTE
  6. FLOOR PLAN KEYNOTE
  7. FLOOR PLAN KEYNOTE
  8. FLOOR PLAN KEYNOTE
  9. FLOOR PLAN KEYNOTE
  10. FLOOR PLAN KEYNOTE
  11. FLOOR PLAN KEYNOTE
  12. FLOOR PLAN KEYNOTE



**FAIRVIEW 30-JUNIT CONDOMINIUM**  
30-J UNIT CONDOMINIUM  
ARCHITECTS

3RD FLOOR CONSTRUCTION PLAN  
A-2.2



No.	DESCRIPTION	DATE

**FAIRVIEW 30-JUNT CONDOMINIUM**  
30 JUNT, SAN FRANCISCO, CA 94107

ROOF PLAN

A-2.3

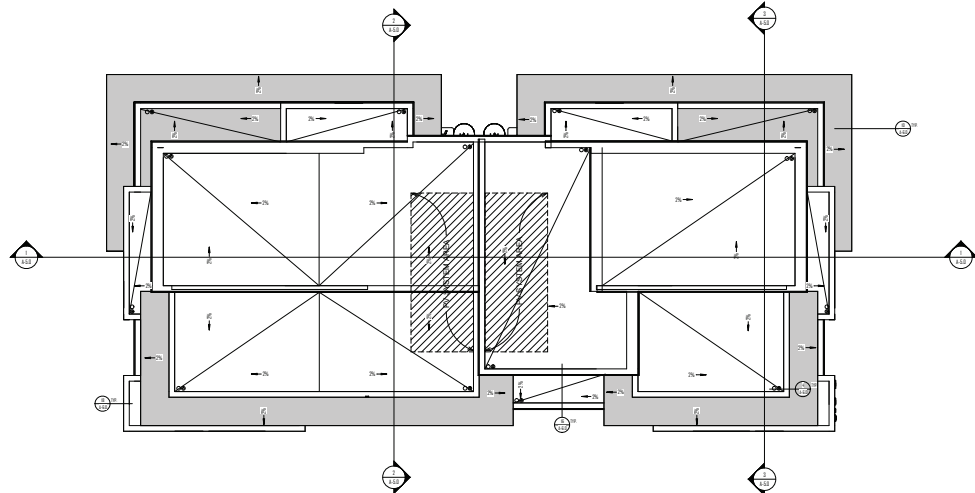

**1 ROOF PLAN (BUILDING #1)**  
1/4" = 1'-0"

- FLOOR PLAN NOTES**
- THE WORK SHOWN ON THIS SET OF PLANS IS THE RESULT OF VISUAL VERIFICATION AND FIELD SURVEYING. A MINIMUM NET CLEARANCE OF 7'6" SHALL BE MAINTAINED AT ALL TIMES. THE MINIMUM CLEARANCE SHALL BE MAINTAINED AT ALL TIMES.
  - DOORS:**  
A. UNLESS OTHERWISE NOTED, ALL DOORS SHALL BE 3'0" WIDE.  
B. ALL DOORS SHALL BE 2'-6" HIGH.  
C. ALL DOORS SHALL BE 1'-6" RISE.  
D. ALL DOORS SHALL BE 1'-6" RISE.
  - WINDOWS:**  
A. UNLESS OTHERWISE NOTED, ALL WINDOWS SHALL BE 3'-0" WIDE.  
B. ALL WINDOWS SHALL BE 4'-0" HIGH.  
C. ALL WINDOWS SHALL BE 1'-6" RISE.
  - CEILING:**  
A. UNLESS OTHERWISE NOTED, ALL CEILING SHALL BE 8'-0" HIGH.  
B. ALL CEILING SHALL BE 8'-0" HIGH.
  - FLOOR:**  
A. UNLESS OTHERWISE NOTED, ALL FLOOR SHALL BE 4'-0" HIGH.  
B. ALL FLOOR SHALL BE 4'-0" HIGH.
  - STAIRS:**  
A. UNLESS OTHERWISE NOTED, ALL STAIRS SHALL BE 3'-0" WIDE.  
B. ALL STAIRS SHALL BE 4'-0" HIGH.

- FLOOR PLAN LEGEND**
- WINDOW: UNLESS OTHERWISE NOTED, ALL WINDOWS SHALL BE 3'-0" WIDE BY 4'-0" HIGH WITH A 1'-6" RISE.
  - DOOR: UNLESS OTHERWISE NOTED, ALL DOORS SHALL BE 3'-0" WIDE BY 6'-8" HIGH WITH A 1'-6" RISE.
  - WINDOW WITH PANE: UNLESS OTHERWISE NOTED, ALL WINDOWS SHALL BE 3'-0" WIDE BY 4'-0" HIGH WITH A 1'-6" RISE.
  - WINDOW WITH GLASS BLOCK: UNLESS OTHERWISE NOTED, ALL WINDOWS SHALL BE 3'-0" WIDE BY 4'-0" HIGH WITH A 1'-6" RISE.
  - WINDOW WITH SCREEN: UNLESS OTHERWISE NOTED, ALL WINDOWS SHALL BE 3'-0" WIDE BY 4'-0" HIGH WITH A 1'-6" RISE.
  - WINDOW WITH SHUTTER: UNLESS OTHERWISE NOTED, ALL WINDOWS SHALL BE 3'-0" WIDE BY 4'-0" HIGH WITH A 1'-6" RISE.
  - WINDOW WITH BLIND: UNLESS OTHERWISE NOTED, ALL WINDOWS SHALL BE 3'-0" WIDE BY 4'-0" HIGH WITH A 1'-6" RISE.
  - DOOR WITH HANDLE: UNLESS OTHERWISE NOTED, ALL DOORS SHALL BE 3'-0" WIDE BY 6'-8" HIGH WITH A 1'-6" RISE.
  - DOOR WITH LOCK: UNLESS OTHERWISE NOTED, ALL DOORS SHALL BE 3'-0" WIDE BY 6'-8" HIGH WITH A 1'-6" RISE.
  - DOOR WITH KNOB: UNLESS OTHERWISE NOTED, ALL DOORS SHALL BE 3'-0" WIDE BY 6'-8" HIGH WITH A 1'-6" RISE.
  - DOOR WITH PULL: UNLESS OTHERWISE NOTED, ALL DOORS SHALL BE 3'-0" WIDE BY 6'-8" HIGH WITH A 1'-6" RISE.
  - DOOR WITH PUSH: UNLESS OTHERWISE NOTED, ALL DOORS SHALL BE 3'-0" WIDE BY 6'-8" HIGH WITH A 1'-6" RISE.
  - DOOR WITH KNOB AND LOCK: UNLESS OTHERWISE NOTED, ALL DOORS SHALL BE 3'-0" WIDE BY 6'-8" HIGH WITH A 1'-6" RISE.
  - DOOR WITH KNOB AND HANDLE: UNLESS OTHERWISE NOTED, ALL DOORS SHALL BE 3'-0" WIDE BY 6'-8" HIGH WITH A 1'-6" RISE.
  - DOOR WITH KNOB AND PULL: UNLESS OTHERWISE NOTED, ALL DOORS SHALL BE 3'-0" WIDE BY 6'-8" HIGH WITH A 1'-6" RISE.
  - DOOR WITH KNOB AND PUSH: UNLESS OTHERWISE NOTED, ALL DOORS SHALL BE 3'-0" WIDE BY 6'-8" HIGH WITH A 1'-6" RISE.

**ABBREVIATIONS**

SYMBOL	DESCRIPTION
1	ROOM
2	DOOR
3	WINDOW
4	CEILING
5	FLOOR
6	STAIR
7	ELEVATION
8	SECTION
9	FINISH
10	NOTE

**WINDOW SCHEDULE**

NO.	FINISH	NO.	FINISH	NO.	FINISH
101	CASA	201	CASA	301	CASA
102	CASA	202	CASA	302	CASA
103	CASA	203	CASA	303	CASA
104	CASA	204	CASA	304	CASA
105	CASA	205	CASA	305	CASA
106	CASA	206	CASA	306	CASA
107	CASA	207	CASA	307	CASA
108	CASA	208	CASA	308	CASA
109	CASA	209	CASA	309	CASA
110	CASA	210	CASA	310	CASA

**DOOR SCHEDULE**

NO.	FINISH	NO.	FINISH	NO.	FINISH
101	CASA	201	CASA	301	CASA
102	CASA	202	CASA	302	CASA
103	CASA	203	CASA	303	CASA
104	CASA	204	CASA	304	CASA
105	CASA	205	CASA	305	CASA
106	CASA	206	CASA	306	CASA
107	CASA	207	CASA	307	CASA
108	CASA	208	CASA	308	CASA
109	CASA	209	CASA	309	CASA
110	CASA	210	CASA	310	CASA

**FLOOR PLAN KEYNOTE**

NO.	FINISH	NO.	FINISH	NO.	FINISH
101	CASA	201	CASA	301	CASA
102	CASA	202	CASA	302	CASA
103	CASA	203	CASA	303	CASA
104	CASA	204	CASA	304	CASA
105	CASA	205	CASA	305	CASA
106	CASA	206	CASA	306	CASA
107	CASA	207	CASA	307	CASA
108	CASA	208	CASA	308	CASA
109	CASA	209	CASA	309	CASA
110	CASA	210	CASA	310	CASA

**FLOOR PLAN KEYNOTE**

NO.	FINISH	NO.	FINISH	NO.	FINISH
101	CASA	201	CASA	301	CASA
102	CASA	202	CASA	302	CASA
103	CASA	203	CASA	303	CASA
104	CASA	204	CASA	304	CASA
105	CASA	205	CASA	305	CASA
106	CASA	206	CASA	306	CASA
107	CASA	207	CASA	307	CASA
108	CASA	208	CASA	308	CASA
109	CASA	209	CASA	309	CASA
110	CASA	210	CASA	310	CASA



**Eric Tsang Architects**

ERIC CHANG TSANG, AIA  
 AIA # 100000000  
 100000000  
 100000000



NO.	DESCRIPTION	DATE

**FAIRVIEW 30-UNIT CONDOMINIUM**  
 3000 FAIRVIEW DRIVE  
 IRVINE, CA 92617

ELEVATION

DATE: A-4.0

MATCH LINE - SEE SHEET L-2

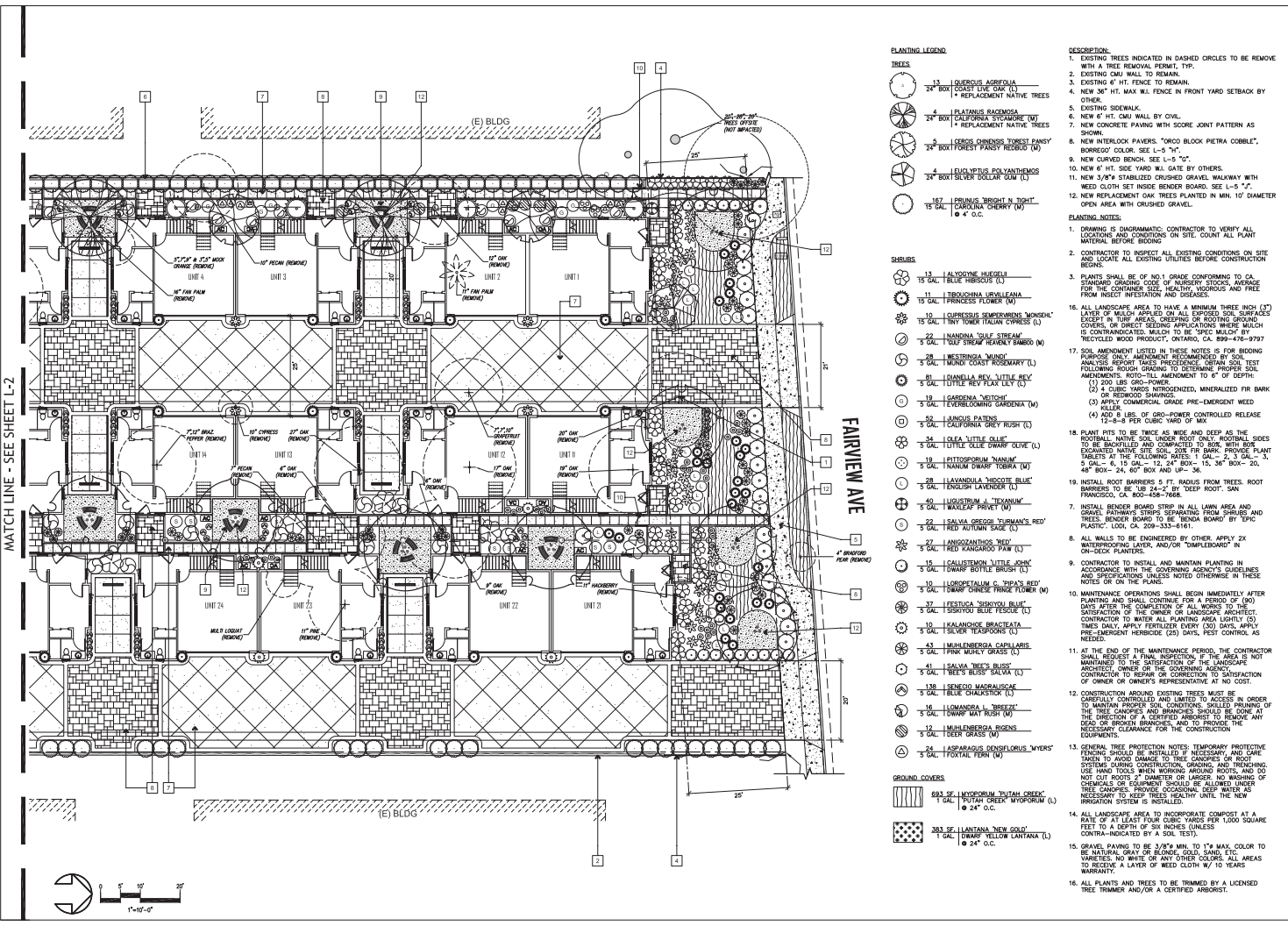

- PLANTING LEGEND**
- TREES**
- 13 QUERCUS AGROFOLIA
  - 24 BOX COAST LIVE OAK (L)
  - 1 REPLACEMENT NATIVE TREES
  - 4 PLATANUS RADICOSA
  - 24 BOX CALIFORNIA SYCAMORE (M)
  - 1 REPLACEMENT NATIVE TREES
  - 5 LEUCO DUNEDON TORREY BANYAN
  - 24 BOX FORESTY PANDY REDBUD (M)
  - 4 LEUCO WILDE FOR VANDIENHOS
  - 24 BOX SILVER SOLAR OAK (L)
  - 187 FRANKS BRIGHT NIGHT
  - 15 GAL. CHERRY (M)
  - 4" O.C.
- SHRUBS**
- 13 LALDOONE HEDGE
  - 15 GAL. BLUE THROAT (L)
  - 11 TROCHILUS LUTEICAPILLUS
  - 1 GAL. PRINCESS FLOWER (M)
  - 10 LUPRUSUS SERPENSUS 'MONSIEUR'
  - 3 GAL. TRY THORNTAIL CYPRESS (L)
  - 22 MANDARIN 'SILENT STREAM'
  - 3 GAL. 'SILENT STREAM' HEAVELY BAMBOO (M)
  - 28 WESTINGHA MUNG
  - 3 GAL. 'HEAVY DUST' ROSEMARY (L)
  - 18 CHANDLER 'LITTLE BEY'
  - 3 GAL. 'LITTLE BEY' FLAX LILY (L)
  - 4 CALIFORNIA GREY (M)
  - 19 CAROLINA YEW
  - 4 CALIFORNIA GREY (M)
  - 52 LAUNUS PATENS
  - 3 GAL. CALIFORNIA GREY RUST (L)
  - 34 OLEA LITTLE OLIVE
  - 3 GAL. 'LITTLE OLIVE' DWARF OLIVE (L)
  - 19 PITTOBOSPORUM 'NANUM'
  - 3 GAL. 'NANUM' DWARF TOBIRA (M)
  - 28 LAVANDULA 'MADRID BLUE'
  - 3 GAL. 'LAVANDULA' LAVENDER (L)
  - 40 LIGULSTRUM 'J. TERNANUM'
  - 3 GAL. 'LIGULSTRUM' PRIVATE (M)
  - 27 ANAGAZATHUS 'RED'
  - 3 GAL. 'RED' KANGAROO PAW (L)
  - 3 GAL. 'LAWSON' BOTTLE BRUSH (L)
  - 10 LOROPETALUM 'C. THAPA'S RED'
  - 3 GAL. 'LAWSON' BOTTLE BRUSH (M)
  - 37 FEDERICA 'SODORU BLUE'
  - 3 GAL. 'SODORU' BLUE FESUDE (L)
  - 10 KALANCHOE BRACIATA
  - 3 GAL. 'SEVER' REDSPICE (L)
  - 43 MIMULNERGIA CAPILLARIS
  - 3 GAL. 'FRANK MURLY' GRASS (L)
  - 41 SALVA 'WEE'S BLOSS'
  - 3 GAL. 'WEE'S BLOSS' SALVIA (L)
  - 138 SENCIO MACRALSICAC
  - 3 GAL. 'LITTLE CHALKSTICK' (L)
  - 16 LOMANDIA 'L. TRIDENT'
  - 3 GAL. 'LAWSON' BOTTLE BRUSH (M)
  - 12 MIMULNERGIA BIGNES
  - 3 GAL. 'DEER GRASS' (M)
  - 24 ASPARAGUS DENSOBLORUS 'MYERS'
  - 3 GAL. 'FOXTAIL TERN' (M)
- GROUND COVERS**
- 493 SF. 'MIDWINTER' 'TULAH CREEK'
  - 1 GAL. 'PUTAH CREEK' MITROPORUM (L)
  - 24" O.C.
  - 383 SF. LANTANA 'NEW GOLD'
  - 1 GAL. 'EDWARD YELLOW LANTANA' (L)
  - 24" O.C.
- DESCRIPTION**
1. EXISTING TREES INDICATED IN DASHED CIRCLES TO BE REMOVED WITH A TREE REMOVAL PERMIT, TYP.
  2. EXISTING CMU WALL TO REMAIN.
  3. EXISTING 4 FT. FENCE TO REMAIN.
  4. NEW 36" HT. MAX. AL. FENCE IN FRONT YARD SETBACK BY OTHER.
  5. EXISTING SIDEWALK.
  6. NEW 6" HT. CMU WALL BY CIVIL.
  7. NEW CONCRETE PAVING WITH SCORE. UNIT PATTERN AS SHOWN.
  8. NEW INTERLOCK PAVERS, "ORCO BLOCK PIETRA COBBLE", BORNEGO COLOR, SEE L-5 "H".
  9. NEW CURVED BENCH, SEE L-5 "O".
  10. NEW 6" HT. SIDE YARD WALL GATE BY CIVIL.
  11. NEW 3/8" STABILIZED CRUSHED GRAVEL WALKWAY WITH WEED CLOTH SET INSIDE BENDER BOARD, SEE L-5 "J".
  12. NEW REPLACEMENT OAK TREES PLANTED IN MIN. 10" DIAMETER OPEN AREA WITH CRUSHED GRAVEL.
- PLANTING NOTES:**
1. DRAWING IS DIAGRAMMATIC. CONTRACTOR TO VERIFY ALL LOCATIONS AND CONDITIONS ON SITE. COORDINATE ALL PLANTS MATERIAL BEFORE BOONG.
  2. CONTRACTOR TO REMOVE ALL EXISTING CONDITIONS ON SITE AND LOCATE ALL EXISTING UTILITIES BEFORE CONSTRUCTION BEGINS.
  3. PLANTS SHALL BE OF NO. 1 GRADE CONFORMING TO CA STANDARDS AND CONDITION ON SITE. HEALTHY, WIGGROSS AND FREE FROM INSECT INFESTATION AND DISEASES.
  4. ALL LANDSCAPE AREA TO HAVE A MINIMUM THREE (3) INCH (3") LAYER OF MULCH APPLIED ON ALL EXPOSED SOIL SURFACES. MULCH TO BE CONTRA-INDICATED. MULCH TO BE SPECIFIC MULCH BY "RECYCLED WOOD PRODUCT", ONTARIO, CA. 899-476-9797.
  5. SOIL AMENDMENT LISTED IN THESE NOTES IS FOR REDDING PURPOSE ONLY. AMENDMENT RECOMMENDED BY SOIL ANALYSE REPORT. SOIL AMENDMENT TO BE OBTAINED FROM SOIL TEST FOLLOWING ROUGH GRADING TO DETERMINE PROPER SOIL AMENDMENTS. ROOT-ZONE AMENDMENT 12" OR DEEPER.
    - (1) 200 LBS. GPO-POWER
    - (2) 400 LBS. COMMERCE PRE-EMERGENT WEED
    - (3) 400 LBS. GPO-POWER
    - (4) ADD 0 LBS. OF GPO-POWER CONTROLLED RELEASE
  6. ALL WALLS TO BE ENGINEERED BY OTHER. APPLY 2X WATERPROOFING LAYER AND/OR "COMBERLOCK" IN ON-DECK PLANTERS.
  7. INSTALL BENDER BOARD STRIP IN ALL LAWN AREA AND GRAVEL PATHWAY STRIPS SEPARATING FROM SHRUBS AND TREES. BENDER BOARD TO BE "BONDA BOARD" BY ENH. PLASTIC, L.O.O.L. CA. 209-333-6161.
  8. ALL WALLS TO BE ENGINEERED BY OTHER. APPLY 2X WATERPROOFING LAYER AND/OR "COMBERLOCK" IN ON-DECK PLANTERS.
  9. CONTRACTOR TO INSTALL AND MAINTAIN PLANTING IN ACCORDANCE WITH THE GOVERNING AGENCY'S GUIDELINES AND SPECIFICATIONS UNLESS NOTED OTHERWISE IN THESE NOTES OR ON THE PLANS.
  10. MAINTENANCE OPERATIONS SHALL BEGIN IMMEDIATELY AFTER PLANTING AND SHALL CONTINUE FOR A PERIOD OF 90 DAYS AFTER THE COMPLETION OF ALL WORKS TO BE MAINTAINED. CONTRACTOR TO MAINTAIN PLANTING IN ACCORDANCE WITH THE GOVERNING AGENCY'S GUIDELINES AND SPECIFICATIONS UNLESS NOTED OTHERWISE IN THESE NOTES OR ON THE PLANS.
  11. AT THE END OF THE MAINTENANCE PERIOD, THE CONTRACTOR SHALL REQUEST A FINAL INSPECTION. IF THE AREA IS NOT MAINTAINED TO THE SATISFACTION OF THE LANDSCAPE ARCHITECT, THE CONTRACTOR SHALL BE RESPONSIBLE FOR THE REPAIR OF THE WORKS TO THE SATISFACTION OF THE OWNER OR OWNER'S REPRESENTATIVE AT NO COST.
  12. CONSTRUCTION AROUND EXISTING TREES MUST BE CAREFULLY CONTROLLED AND LIMITED TO ACCESS IN ORDER TO MAINTAIN PROPER SOIL CONDITIONS. SKILLED PRUNING OF THE TREE CANOPIES AND BRANCHED SHOULD BE DONE AT THE DIRECTION OF A CERTIFIED ARBORIST TO REMOVE ANY DEAD OR BROWN BRANCHES AND TO PROVIDE THE NECESSARY CLEARANCE FOR THE CONSTRUCTION EQUIPMENTS.
  13. GENERAL TREE PROTECTION NOTES: TEMPORARY PROTECTIVE FENCING SHOULD BE INSTALLED IF NECESSARY AND OPERATIONAL DURING CONSTRUCTION, GRADING, AND TRENCHING. USE HAND TOOLS WHEN WORKING AROUND ROOTS, AND DO NOT CUT ROOTS 2" DIAMETER OR LARGER. NO WASHING OF OILS OR EQUIPMENT SHOULD BE ALLOWED UNDER BRIGATION SYSTEM IS INSTALLED.
  14. ALL LANDSCAPE AREA TO INCORPORATE COMPOST AT A RATE OF AT LEAST FOUR CUBIC YARDS PER 1,000 SQUARE FEET TO A DEPTH OF 6" UNLESS CONTRA-INDICATED BY A SOIL TEST.
  15. GRAVEL PAVING TO BE 3/8" MAX. TO 1" MAX. COLOR TO BE NATURAL SAND OR BROWN SAND, ETC. VARIETIES, NO WHITE OR ANY OTHER COLORS. ALL AREAS TO RECEIVE A LAYER OF WEED CLOTH BY 10 YEARS.
  16. ALL PLANTS AND TREES TO BE TRIMMED BY A LICENSED TREE TRIMMER AND/OR A CERTIFIED ARBORIST.

**TWO TREES DESIGN, INC.**  
 1000 S. FAIRVIEW AVE.  
 ARCADIA, CA 91709  
 (909) 441-1111  
 www.twotreesdesign.com

**LANDSCAPE PLANTING PLAN (SITE NORTH)**

**FAIRVIEW 30-UNIT CONDOMINIUM**  
 15145 FAIRVIEW AVE.  
 ARCADIA, CA

DATE	REVISIONS

SCALE: AS SHOWN  
 PROJECT NO: F2504  
 DRAWN BY: HTP  
 CHECKED BY: HTP

SHEET: **L-1**  
 OF 6 SHEETS

© 2020 TWO TREES DESIGN, INC. All rights reserved. This drawing is the property of TWO TREES DESIGN, INC. and is not to be reproduced, stored in a retrieval system, or transmitted in any form or by any means, electronic, mechanical, photocopying, recording, or by any information storage and retrieval system, without the prior written permission and consent of TWO TREES DESIGN, INC.

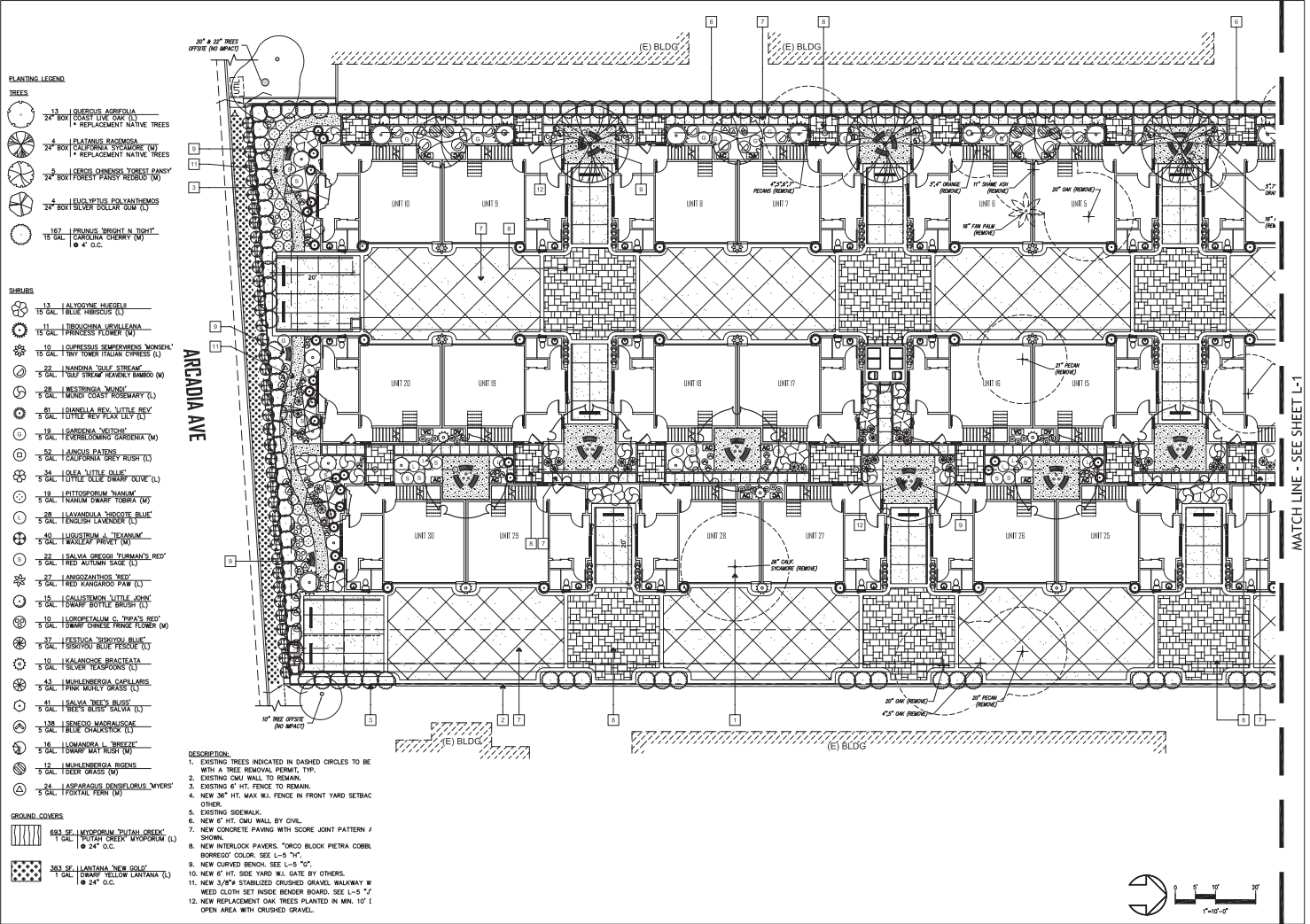

**TWO TREES DESIGN, INC.**  
 1000 N. GARDEN AVENUE, SUITE 100  
 ANAHEIM, CA 92810  
 TEL: 714.771.1111  
 WWW.TWOTREESDESIGN.COM

**LANDSCAPE PLANTING PLAN (SITE SOUTH)**

**FAIRVIEW 30-UNIT CONDOMINIUM**  
 5145 S. FAIRVIEW AVE.  
 ANAHEIM, CA

DATE	REVISIONS

SCALE: AS SHOWN  
 PROJECT NO: F2504  
 DRAWN BY: HTY  
 CHECKED BY: HTY

SHEET: **L-2**  
 OF 6 SHEETS

© 2024 TWO TREES DESIGN, INC. ALL RIGHTS RESERVED. THESE PLANS ARE NOT TO BE REPRODUCED, COPIED OR CAPPED IN ANY FORM OR MANNER WITHOUT THE WRITTEN PERMISSION AND CONSENT OF TWO TREES DESIGN, INC.

# Attachment No. 8

## Tentative Tract Map

**PREPARED BY:**  
 JACK LEE, R.C.E. 40870  
 CALLAND ENGINEERING, INC.  
 576 E LAMBERT ROAD  
 BREAA, CALIFORNIA 92821  
 TEL: (714) 671-1050  
 FAX: (714) 671-1090

**OWNER:**  
 ANNIE CHIAN-518 FAIRVIEW LLC  
 P.O. BOX 504, WALNUT, CA 91788  
 TEL: 909-263-2633  
 ANNIE@BULTBYRODEO.COM

# TENTATIVE TRACT MAP NO. 84910

IN THE CITY OF ARCADIA, COUNTY OF LOS ANGELES  
 STATE OF CALIFORNIA

PORTIONS OF LOT 28 OF TRACT NO. 3430, IN THE CITY OF ARCADIA, COUNTY OF LOS ANGELES, STATE OF CALIFORNIA, AS PER MAP RECORDED IN BOOK 42 PAGE 32 OF MAPS, IN THE OFFICE OF THE COUNTY RECORDER OF SAID COUNTY.

APN: 5778-005-012 & 013  
 FOR CONDOMINIUM PURPOSES

**BENCH MARK:**  
 B.M. NUMBER #158  
 DUARTE ROAD & LA CADENA, AVE. CHIS.  
 \* 15' NORTH OF CATCH BASIN AT  
 NORTHEAST CURB RETURN.  
 ELEVATION: 457.45'

**SEWER NOTE:**  
 SEWER LATERAL LOCATION AND SIZE TO  
 BE FIELD VERIFIED BY THE CONTRACTOR  
 PRIOR TO CONNECTION.



**CALLAND ENGINEERING, INC.**  
 dba QUARTTECH CONSULTANTS  
 576 E. LAMBERT ROAD, BREAA, CA 92821  
 TEL: (714) 671-1050 FAX: (714) 671-1090

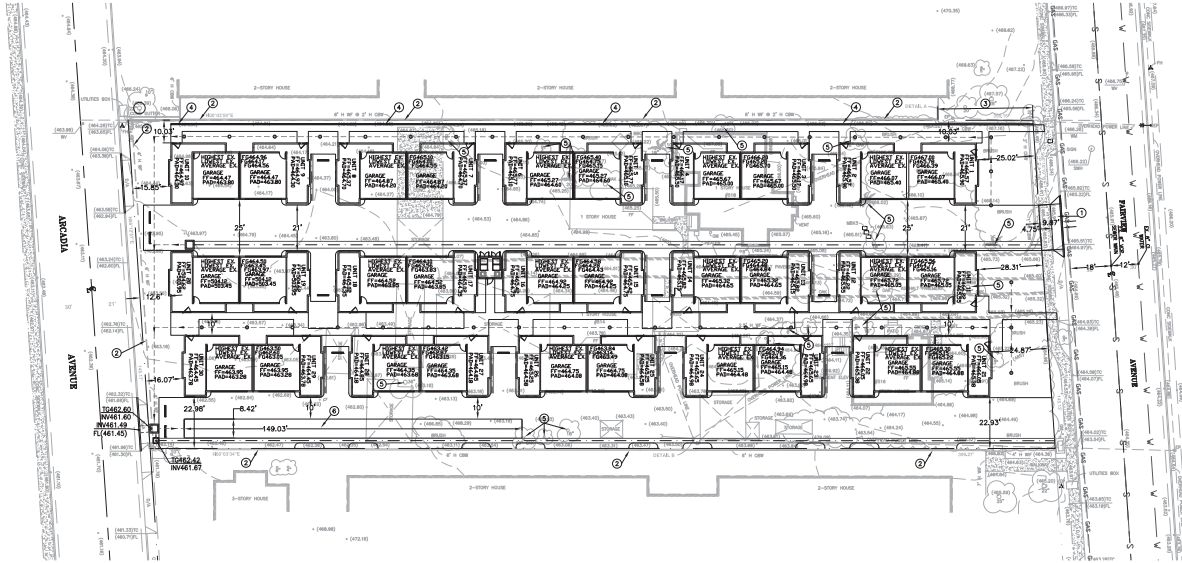

- LEGEND**
- (462.1).....EXISTING ELEVATION
  - 520.00.....PROPOSED ELEVATION
  - (466).....EXISTING CONTOUR
  - .....DRAINAGE PATTERN
  - .....EXISTING STRUCTURE
  - .....PROPOSED STRUCTURE
  - .....PROPOSED CONCRETE AREA

- ABBREVIATIONS**
- CBW..... CONC. BLOCK WALL
  - CK&G..... CURB AND GUTTER
  - DIA..... DRIVEWAY APRON
  - DWY..... DRIVEWAY
  - EP..... EDISON POLE
  - EX..... EXISTING
  - FH..... FIRE HYDRANT
  - FL..... FLOW LINE ELEVATION
  - GM..... GAS METER
  - MH..... MAN HOLE
  - SMH..... SEWER MANHOLE
  - SW..... SIDEWALK
  - SD..... STORM DRAIN
  - TBR..... TO BE REMOVED
  - TC..... TOP OF CURB ELEVATION
  - WF..... WOODEN FENCE
  - WV..... WATER VALVE

- PROPOSED NOTES:**
- PROPOSE NEW DRIVEWAY APPROACH PER CITY STD. 801-1.
  - EXISTING WALL/FENCE TO REMAIN PER ARCHITECTURAL PLAN
  - EXISTING WALL/FENCE TO BE REMOVED PER ARCHITECTURAL PLAN
  - PROPOSED NEW 6" CURB
  - EXISTING TREE TO BE REMOVED
  - PROPOSED INFILTRATION CHAMBER

**UTILITY SERVICES:**

WATER - CITY OF ARCADIA WATER  
 SEWER - CITY OF ARCADIA SEWER  
 GAS - SOUTHERN CALIFORNIA GAS CO.  
 ELECTRICAL - SOUTHERN CALIFORNIA EDISON CO.  
 TELEPHONE - PACIFIC BELL  
 SCHOOL - ARCADIA UNIFIED SCHOOL  
 FIRE - CITY OF ARCADIA FIRE DEPARTMENT  
 SHERIFF - CITY OF ARCADIA POLICE

**NOTES:**

ZONE: R-3  
 APN: 5778-005-012 & 013  
 NO. OF EX. LOT:  
 NO. OF PROP. UNITS: 30  
 PROPERTY SIZE: 57,814 SF  
 NO. OF STORIES: 3  
 SEWERAGE DISPOSAL: BY GRAVITY SEWER PIPES TO STREET MAIN.

Scale: 1" = 10'  
 North Arrow  
 Professional Engineer Seal: Jack Lee, R.C.E. 40870, State of California

**REVISIONS**

NO.	DATE	DESCRIPTION

**PROJECT LOCATION:**  
 514 & 518 FAIRVIEW AVE.  
 ARCADIA, CA 91007

DATE: 10/17/2025  
 JOB NO.: 25-225-024  
 SCALE: 1" = 10'  
 SHEET NO.: T-1  
 SHEET 1 OF 1 SHEET

# Attachment No. 9

Arborist Report, dated March 25, 2026

**514-518 Fairview Ave Arcadia, CA 91007**

Prepared for:

**Eric Tsang Architects  
440 E Huntington Dr. Suite 356  
Arcadia, CA 91006**

**August 14, 2025**

**Revised March 25, 2026**

Prepared by:

***Javier Cabral Consulting Arborist***  
International Society of Arborists # WE- 8116A

1390 El Sereno Ave  
Pasadena, California 91103  
(626)818-8704  
[jtcabral@sbcglobal.net](mailto:jtcabral@sbcglobal.net)



## Table of contents

Summary & Background & Assignment -----	pg. 3
Google Earth Image & Site Conditions -----	pg. 4
List Inventory -----	pg. 5 & 6
Site Plan With Trees-----	pg. 7 & 8
Tree Pictures -----	pg. 9 thru 30
Replacement Trees -----	pg. 31 & 32
Arborist Signature Page -----	pg. 33
Certificate Of Performance -----	pg. 34

## Summary

Mr. Tsang,

You have retained my consulting arborist services to provide a tree inventory and tree protection for the property described as 514-518 Fairview Ave Arcadia, CA 91007. You are in the process of demolishing the existing homes and building 30 new units.

## Background and assignment

Mr. Tsang has requested that I provide the following arboricultural services.

- 1) Identify all trees on the property and label them on the architectural drawings as provided to the arborist by Mr. Eric Tsang.
- 2) Evaluate the current health of the trees and make recommendations based on their health.
- 3) Provide a tree protection plan for protected trees to remain in place.

The following report is based on my site visit on August 13, 2025, and my analysis of the trees, site plan, and the surrounding landscape. For this report, I will address these trees as **Trees # 1 thru 32**.

**Site conditions**

Several one-story single-family homes currently exists on this property located 514-518 Fairview Ave Arcadia, CA 91007.

- 1) There are (32) total trees on the subject project property. Of the total only (11) qualify for protection based on the City of Arcadia Tree Protection Ordinance. All on-site for removal due to its location against the foundation of the proposed new house.

**Google Earth Image**



List Inventory pg. 1

Tree #	Common name	Botanical name	Diameter at 4.5 feet in inches	Height (in feet)	Spread (in feet)	Health condition rating	Protection status	REMOVE or PRESERVE	Comments
1	Bradford pear	Pyrus calleryana	4	18	6	C-	Yes as city tree	REMOVE	Severely damaged trunk
2	Coast live oak	Quercus agrifolia	19	55	38	B	Yes	REMOVE	
3	Coast live oak	Quercus agrifolia	17	55	30	B	Yes	REMOVE	
4	Coast live oak	Quercus agrifolia	27	60	39	B	Yes	REMOVE	
5	Coast live oak	Quercus agrifolia	6	15	15	B	Yes	REMOVE	Severe lean & severe dead wood
6	Pecan	Carya illinoensis	7	13	12	B	No	REMOVE	
7	Brazilian pepper	Scinus terebinthifolius	7+12	33	30	C+	No	REMOVE	
8	Cypress	Cupressus sempervirens	10	55	6	B	No	REMOVE	
9	Pecan	Carya illinoensis	21	60	38	B	No	REMOVE	
10	Pecan	Carya illinoensis	4+5+6	30	14	B	No	REMOVE	
11	Pecan	Carya illinoensis	7	35	13	B	No	REMOVE	
12	Orange	Citrus sinensis	3+4	12	12	D	No	REMOVE	
13	Shamel ash	Fraxinus uhdei	11	48	14	C	No	REMOVE	Large trunk cavity
14	Coast live oak	Quercus agrifolia	20	50	39	B	Yes	REMOVE	

List Inventory pg. 2

Tree #	Common name	Botanical name	Diameter at 4.5 feet in inches	Height (in feet)	Spread (in feet)	Health condition rating	Protection status	REMOVE or PRESERVE	Comments
15	Mexican fan palm	Washingtonia robusta	16	70	12	A	No	REMOVE	
16	Mexican fan palm	Washingtonia robusta	16	70	12	A	No	REMOVE	
17	Mock orange	Pittosporum undulatum	5+7+9	18	12	C	No	REMOVE	
18	Mock orange	Pittosporum undulatum	3+5	18	12	C	No	REMOVE	
19	Pecan	Carya illinoensis	10	40	16	B	No	REMOVE	
20	Coast live oak	Quercus agrifolia	12	28	26	B-	Yes	REMOVE	Poor structure & unbalanced canopy
21	Mexican fan palm	Washingtonia robusta	11	30	12	A	No	REMOVE	
22	Grapefruit	Citrus paradisi	7+7+10	30	18	D-	No	REMOVE	Severe decline, 90% dead
23	Mexican fan palm	Washingtonia robusta	20	16	18	B	No	REMOVE	
24	Common hackberry	Celtis occidentalis	11	33	16	B	No	REMOVE	
25	Coast live oak	Quercus agrifolia	9	30	12	B	Yes	REMOVE	Unbalanced canopy
26	Coast live oak	Quercus agrifolia	6	22	12	B	Yes	REMOVE	Unbalanced canopy
27	Stone pine	Pinus pinea	11	14	17	B	No	REMOVE	
28	Loquat	Eriobotrya japonica	2+2+2+2	12	10	B	No	REMOVE	
29	Pecan	Carya illinoensis	20	70	40	B	No	REMOVE	
30	Coast live oak	Quercus agrifolia	4+5	18	12	B	Yes	REMOVE	
31	Coast live oak	Quercus agrifolia	20	50	33	B	Yes	REMOVE	Severely unbalanced canopy
32	California sycamore	Platanus racemosa	26	30	22	D-	Yes	REMOVE	Severe decline, 90% dead

Site Plan With Trees (full scale)

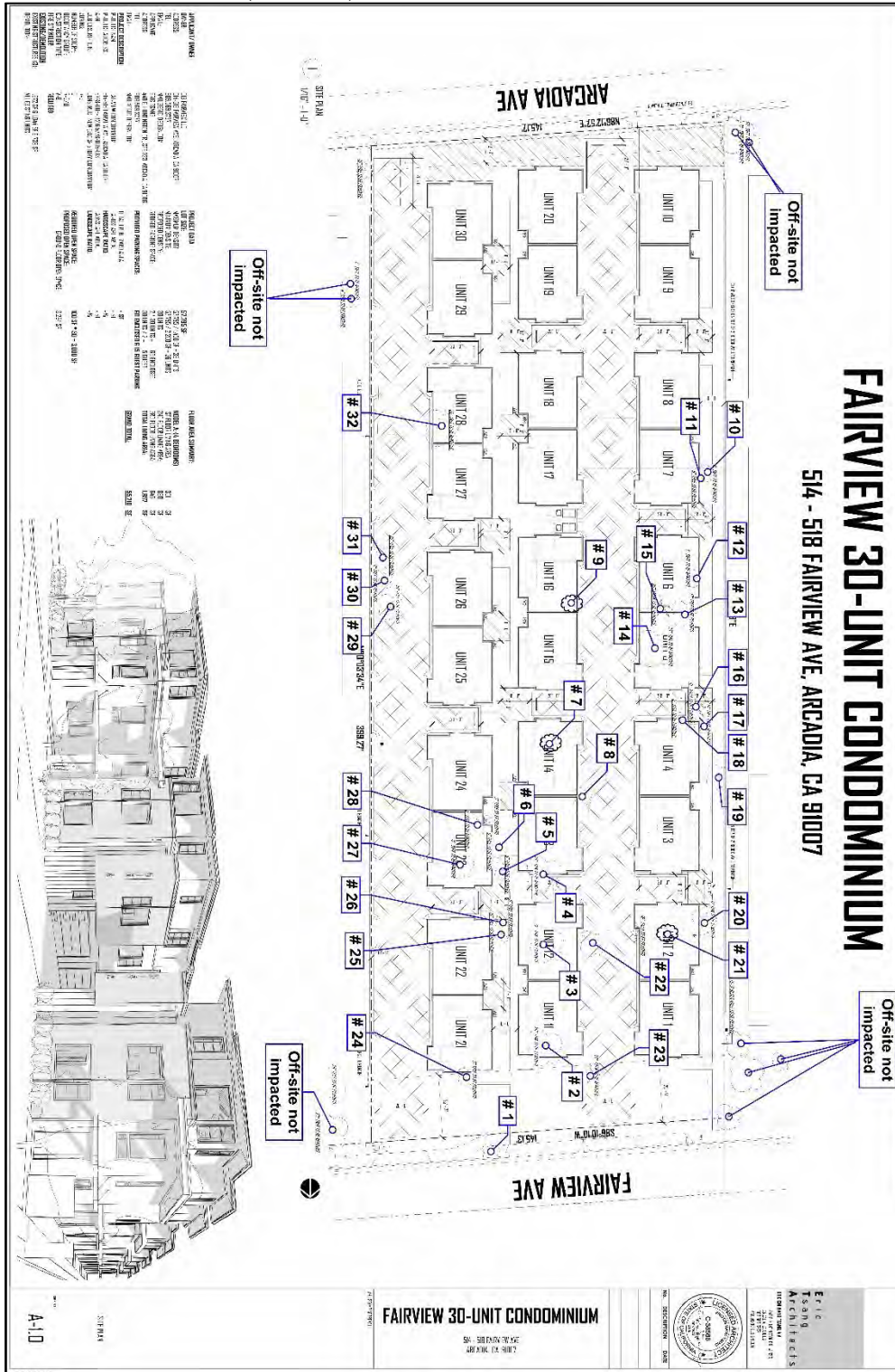

Site Plan With Trees (Cropped)

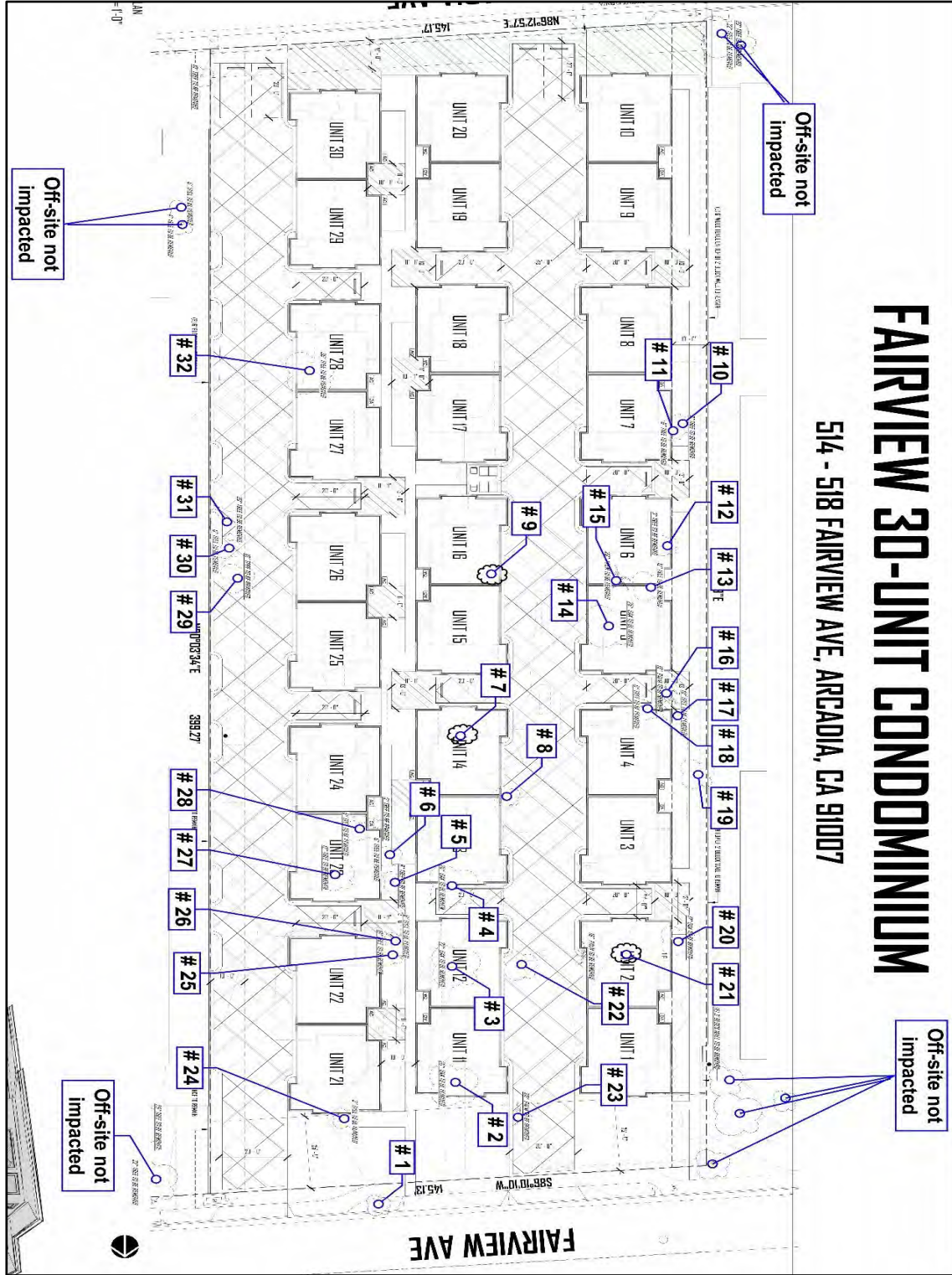

**Tree # 1 (facing east)**



**Tree # 2 (facing south)**



**Tree # 3 (facing southeast)**



**Tree # 4 (facing northeast)**



Tree # 5 & 6 (facing north)



Trees 7 & 8 (facing west)



**Tree # 9 (facing south)**



**Trees 10 & 11 (facing east)**



**Trees 12 & 13 (facing east)**



**Tree 14** (facing east)



**Tree 15** (facing northwest)



Trees 16 thru 18 (facing south)



**Tree # 19** (facing west)



**Trees 20 & 21 (facing south)**



**Tree 22 (facing west)**



**Tree 22 (facing southeast)**



**Tree 24** (facing south)



**Trees 25 & 26 (facing north)**



**Tree 27 (facing west)**



**Tree 28 (facing north)**



**Trees 29 thru 31 (facing south)**



**Tree 32 (facing east)**



# Landscape Plan With Replacement Oak trees

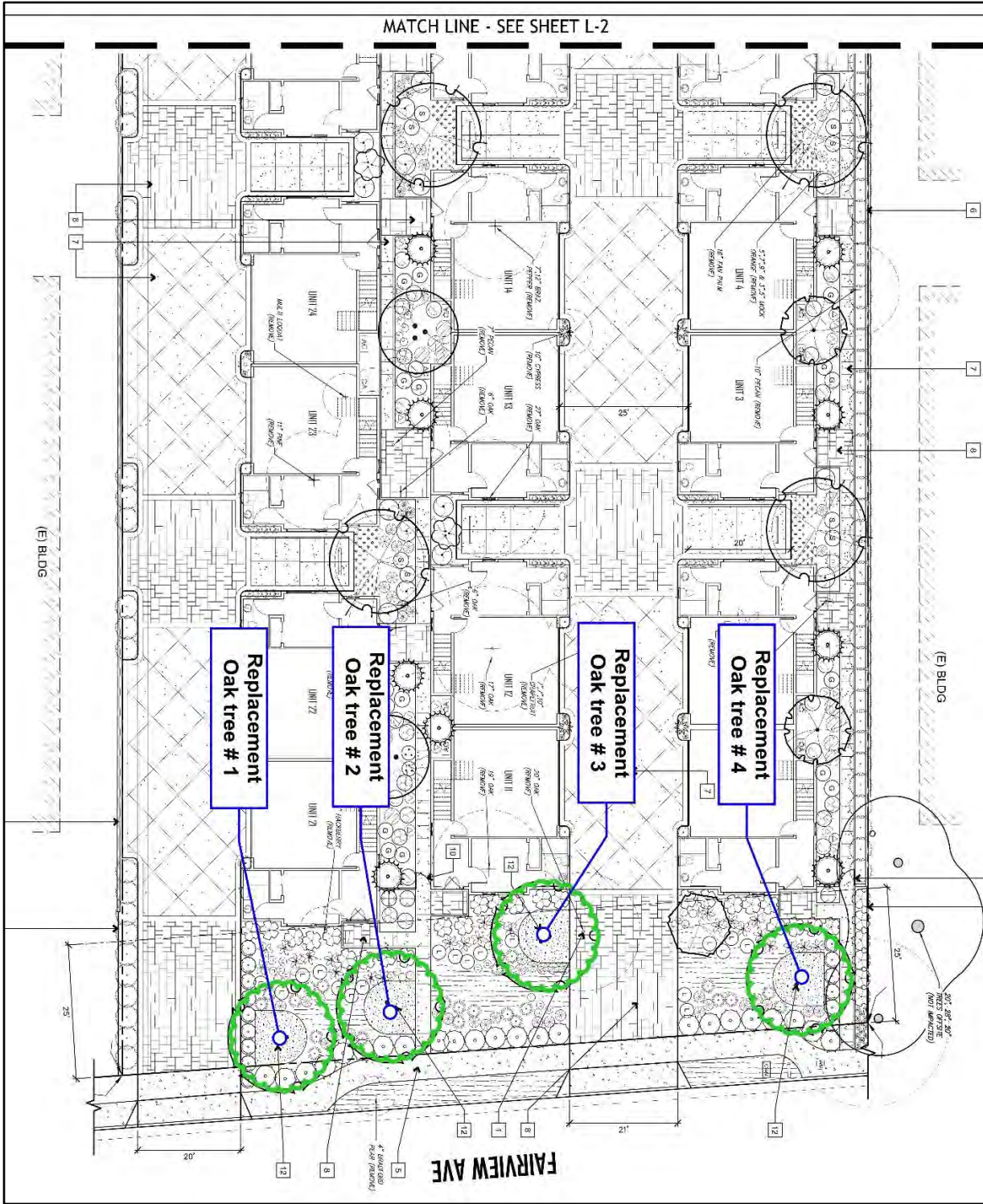

- 1) **There is no room on the rear or side yards for mature or even semi-young Oak trees to expand their roots or canopies.**
- 2) **The proposed four Oak trees in the front yard will barely have enough room for the expansion of their roots and canopies.**
- 3) **Root barriers are recommended along the driveway, buildings and walkways to help prevent future root damage. and**

Thank you and feel free to contact me if you have any questions or concerns.

Yours truly,

Javier Cabral / Consulting arborist  
1390 El Sereno Ave Pasadena, Ca 91103  
International Society of Arboriculture # WE 8116A

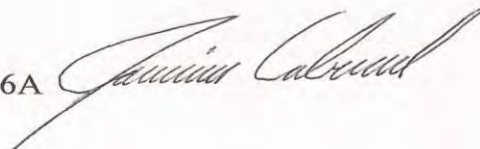
A handwritten signature in black ink, reading "Javier Cabral", written in a cursive style.

## Certificate of Performance & Limiting Conditions

I Javier Cabral certify the following:

- No warranty is made, expressed or implied that problems or deficiencies of the trees or the property will not occur in the future, from any cause. The Arborist shall not be responsible for damages or injuries caused by any tree defects and assume no responsibility for the correction of defects or tree related problems.
- The owner and client of the trees may choose to accept or disregard the recommendations of the Arborist or seek additional advice if the owner decides not to accept the Arborists' findings or recommendations.
- The Arborist has no past, present or future interest in the removal or preservation of any tree. The opinions contained in the Arborist report are independent and objective judgements of the Arborist.
- The findings, opinions, and recommendations of the Arborist are based on based on the physical inspection of said property. The opinions are based on knowledge, experience, and education.
- The Arborist shall not be required to provide testimony, provide site monitoring, provide further documentation for changes beyond the control of the Arborist, be deposed, or to attend any meeting without contractual arrangements for additional fees to the Arborist.
- The Arborist assumes no responsibility for verification of ownership or location of property lines, or for any recommendations based on inaccurate information.
- This Arborist report may not be reproduced without the expressed written permission or the Arborist and the client to whom the report was provided to. Any changes or alteration of this report invalidates the entire report.
- Arborists are tree specialists who use their education, knowledge, training and experience to examine trees, recommend measures to enhance the beauty and health of trees, make recommendations to prevent or minimize damage to trees during and after construction projects, and attempt to reduce the risk of living near trees. Clients may choose to accept or disregard the recommendations of the arborist, or to seek additional advice.
- Arborists cannot detect every condition that could possibly lead to the structural failure of a tree. Trees are living organisms that fail in ways we do not fully understand. Conditions are often hidden within trees and below ground. Arborists cannot guarantee that a tree will be healthy or safe under all circumstances, or for a specified period of time. Likewise, remedial treatments, like any medicine, cannot be guaranteed.
- Treatment, pruning and removal of trees may involve considerations beyond the scope of the arborist's services such as property boundaries, property ownership, site lines, disputes between neighbors, and other issues. Arborists cannot take such considerations into account unless complete and accurate information is disclosed to the arborist. An arborist should then be expected to reasonably rely upon the completeness and accuracy of the information provided.
- Trees can be managed, but they cannot be controlled. To live near trees is to accept some degree of risk. The only way to eliminate all risk associated with trees is to eliminate all trees.

# Attachment No. 10

## Preliminary Exemption Assessment



CITY OF  
ARCADIA

## PRELIMINARY EXEMPTION ASSESSMENT

1. Name or description of project:	MULTI-FAMILY SB 330 APPLICATION NO. SB 330 25-01, TENTATIVE TRACT MAP NO. TTM 26-01 (84910), AND PROTECTED HEALTHY TREE REMOVAL PERMIT NO. TRH 26-02 FOR A NEW 30 UNIT, MULTI-FAMILY RESIDENTIAL CONDOMINIUM DEVELOPMENT LOCATED AT 514 FAIRVIEW AVENUE	
2. Project Location – Identify street address and cross streets or attach a map showing project site (preferably a USGS 15' or 7 1/2' topographical map identified by quadrangle name):	514-518 Fairview Avenue – Located on the south side of Fairview Avenue between Baldwin Avenue and La Cadena Avenue	
3. Entity or person undertaking project:	A.	
	B. Other (Private)	
	(1) Name	518 Fairview LLC
	(2) Address	P.O. Box 504 Walnut, CA 91788
4. Staff Determination:	<p>The Lead Agency's Staff, having undertaken and completed a preliminary review of this project in accordance with the Lead Agency's "Local Guidelines for Implementing the California Environmental Quality Act (CEQA)" has concluded that this project does not require further environmental assessment because:</p>	
a. <input type="checkbox"/>	The proposed action does not constitute a project under CEQA.	
b. <input type="checkbox"/>	The project is a Ministerial Project.	
c. <input type="checkbox"/>	The project is an Emergency Project.	
d. <input type="checkbox"/>	The project constitutes a feasibility or planning study.	
e. <input checked="" type="checkbox"/>	The project is categorically exempt.	
	Applicable Exemption Class:	15332 – Class 32 (Urban In-fill Development)
f. <input type="checkbox"/>	The project is statutorily exempt.	
	Applicable Exemption:	
g. <input type="checkbox"/>	The project is otherwise exempt on the following basis:	
h. <input type="checkbox"/>	The project involves another public agency which constitutes the Lead Agency.	
	Name of Lead Agency:	

Date: April 14, 2026

Staff: Edwin Arreola, Senior Planner

**DATE:** June 16, 2026

**TO:** Honorable Mayor and City Council

**FROM:** Paul Cranmner, Public Works Services Director  
By: Carmen Masud, Deputy Public Works Director

**SUBJECT:** RESCHEDULE THE PUBLIC HEARING FOR THE FISCAL YEAR 2026-27 LEVY AND COLLECTION OF THE ARCADIA CITYWIDE LIGHTING DISTRICT NO. 1  
**CEQA: Not a Project**  
**Recommendation: Approve**

**SUMMARY**

The Citywide Lighting District No. 1 (“Citywide Lighting District” or “District”) was formed in the City of Arcadia pursuant to state law for the purpose of partially funding the ongoing operation, maintenance, and servicing of the City’s street lighting system. At the June 2, 2026, City Council Meeting, the City Council adopted Resolution Nos. 7690 through 7692, which initiated the proceedings for the annual levy and collection of assessments, approved the preliminary Engineer’s Report, and set the public hearing for the June 16, 2026, City Council Meeting.

The notice of Public Hearing was not published in time to meet the circulation requirement. In accordance with The Landscaping and Lighting Act of 1972, the notice for a public hearing must be published at least once in the local newspaper of general circulation at least 10 days prior to the public hearing. It is recommended that the City Council reschedule the public hearing for the Fiscal Year 2026-27 Levy and Collection of the Arcadia Citywide Lighting District No.1 to the July 21, 2026, City Council Meeting.

## **BACKGROUND**

At the June 2, 2026, City Council Meeting, the City Council adopted Resolution Nos. 7690 through 7692, which initiated the proceedings for the annual levy and collection of assessments, approved the preliminary Engineer's Report, and set the public hearing for Tuesday, June 16, 2026, at 7:00 p.m., or as soon thereafter as feasible. See attached, June 2, 2026, Citywide Street Lighting Assessment District Resolutions staff report.

In accordance with the Landscaping and Lighting Act of 1972, the notice for a public hearing must be published at least once in the local newspaper of general circulation, at least ten days prior to the public hearing. On Wednesday, June 3, 2026, the Public Hearing Notice and resolution were sent to the Arcadia's local newspaper of general circulation. Unfortunately, the newspaper changed the time cutoff to submit for publication and staff missed the new deadline by one hour; therefore, the notice of public hearing was not published in time to meet the circulation requirement.

## **DISCUSSION**

To meet the requirements of the Landscaping and Lighting Act of 1972, it is recommended that the City Council reschedule the public hearing for the Fiscal Year 2026-27 Levy and Collection of the Arcadia Citywide Lighting District No. 1 to the July 21, 2026, City Council Meeting. Although the Landscaping and Lighting Act of 1972 requires the resolution of intention to be published with the notice of public hearing, since the Intention Resolution adopted on June 2, 2026, called for a public hearing on June 16, 2026, at 7:00pm, or as soon thereafter as feasible, a new Intention Resolution is not necessary. The notice of public hearing will include information on the rescheduling of the public hearing date and will be published on June 22, 2026. The additional time will ensure that the public hearing is published pursuant to the Landscaping and Lighting Act of 1972.

## **ENVIRONMENTAL ANALYSIS**

The proposed action does not constitute a project under the California Environmental Quality Act ("CEQA") under Section 15061(b)(3) of the CEQA Guidelines, as it can be seen with certainty that it will have no impact on the environment.

**FISCAL IMPACT**

Fees collected under the Citywide Lighting District will help defray the total maintenance costs of lighting in the subject areas. Upon conclusion of the public hearing and adoption of the Engineer’s Report, a total of \$603,980 will be levied and collected under the Citywide Lighting District.

**RECOMMENDATION**

It is recommended that the City Council determine that this action does not constitute a project under the California Environmental Quality Act (“CEQA”); and reschedule the public hearing for the Fiscal Year 2026-27 Levy and Collection of the Arcadia Citywide Lighting District No. 1 to the July 21, 2026, City Council Meeting.

Approved:



Dominic Lazzaretto  
City Manager

Attachments: June 2, 2026, Citywide Street Lighting Assessment staff report  
Resolution No. 7690  
Resolution No. 7691  
Resolution No. 7692

**DATE:** June 2, 2026

**TO:** Honorable Mayor and City Council

**FROM:** Paul Cranmer, Public Works Services Director  
By: Carmen Masud, Deputy Public Works Director

**SUBJECT:** RESOLUTIONS INITIATING PROCEEDINGS FOR THE ANNUAL LEVY AND COLLECTION OF ASSESSMENTS, APPROVING THE PRELIMINARY ENGINEER'S REPORT, DECLARING INTENTION TO LEVY AND COLLECT ASSESSMENTS FOR FISCAL YEAR 2026-27, AND APPOINTING A TIME AND PLACE FOR A PUBLIC HEARING FOR THE ARCADIA CITYWIDE LIGHTING DISTRICT NO. 1

RESOLUTION NO. 7690 INITIATING PROCEEDINGS FOR THE ANNUAL LEVY AND COLLECTION OF ASSESSMENTS FOR THE ARCADIA CITYWIDE LIGHTING DISTRICT NO. 1, PURSUANT TO THE PROVISIONS OF PART 2 OF DIVISION 15 OF THE CALIFORNIA STREETS AND HIGHWAYS CODE AND ORDERING THE PREPARATION OF THE ENGINEER'S REPORT

**CEQA: Not a Project**

**Recommendation: Adopt**

RESOLUTION NO. 7691 APPROVING THE PRELIMINARY ENGINEER'S REPORT OF WILLDAN FINANCIAL SERVICES FOR THE ARCADIA CITYWIDE LIGHTING DISTRICT NO. 1

**CEQA: Not a Project**

**Recommendation: Adopt**

RESOLUTION NO. 7692 DECLARING ITS INTENTION TO LEVY AND COLLECT ASSESSMENTS WITHIN THE ARCADIA CITYWIDE LIGHTING DISTRICT NO. 1 FOR FISCAL YEAR 2026-27 AND APPOINTING A TIME AND PLACE FOR A PUBLIC HEARING

**CEQA: Not a Project**

**Recommendation: Adopt**

## **SUMMARY**

The Arcadia Citywide Lighting District No. 1 (“Citywide Lighting District” or “District”) was formed pursuant to state law for the purpose of partially funding the ongoing operation, maintenance, and servicing of the City’s street lighting system. As proposed, the District’s budget for Fiscal Year 2026-27 increased by 3.57%, or \$53,000. The increase is due to an increase in electricity costs, vehicle maintenance costs, salaries and wages, and City liability insurance costs. Although the budget slightly increased, there is no proposed assessment rate increase for Fiscal Year 2026-27. The annual assessment rate for a single-family property owner in Zone 1 will remain at \$23.69; and will remain at \$40.33 in Zone 2.

It is recommended that the City Council adopt the resolutions initiating proceedings for the annual levy and collection of assessments, approving the preliminary Engineer’s Report, declaring intention to levy and collect assessments for Fiscal Year 2026-27, and appointing a time and place for a public hearing for the Arcadia Citywide Lighting District No. 1.

## **BACKGROUND**

Arcadia’s original Street Lighting District was established in the early 1950s through the Street Lighting Act of 1919 and was set to expire on June 30, 2010. Expiration of the District would have resulted in a loss of approximately \$420,000 in annual revenue to the City beginning in Fiscal Year 2010-11, and would have impeded the ability to properly maintain the City’s streetlights. Renewal of the Street Lighting District could no longer be done through the Street Lighting Act of 1919 because the assessments were based on the value of real property, which Proposition 13 prohibits. Additionally, not all properties within the City were included in the original assessment district, which resulted in an inequity of assessments.

To address this issue, in 2009, the City Council directed the formation of a Citywide Lighting District via the Landscaping and Lighting Act of 1972. Under this Act, assessments are based on the special benefit that street lighting provides to properties within the Citywide Lighting District area. Proposition 218 noticing and balloting requirements were met, and on August 3, 2010, the City Council adopted the Engineer’s Report for the formation of the Citywide Lighting District, approving the levy and collection of assessments beginning in Fiscal Year 2010-11.

To ensure appropriate allocation and annual levy of assessments based on proportional benefits, the Citywide Lighting District established two benefit zones to separate general benefit and special benefit.

- Zone 1 includes properties along major thoroughfares and parcels that receive the general benefit of street lighting along arterial streets.
- Zone 2 includes properties in residential neighborhoods that specifically benefit from maintenance of street lighting on local streets.

In addition to the use of zones, the assessment rate utilizes a weighted methodology of apportionment, referred to as an Equivalent Benefit Unit (“EBU”). The proportional special benefit calculation for each parcel is determined by land use, number of units, and acreage. Furthermore, a benefit multiplier is also employed to account for varying density levels of street lighting within the City, which ranges from a standard level of street lighting to no street lighting. Some areas in the City were developed with less lighting on their streets. These sparsely lit neighborhoods still receive special benefits from local lights, even though their overall lighting density is less than those streets with full lighting; these properties receive 20% of the standard lighting density and pay 20% of the annual assessment rate. Properties in areas of the City that do not have street lighting do not pay a street lighting assessment fee. This methodology has been in place since Fiscal Year 2010-11.

## **DISCUSSION**

The City’s Fiscal Year 2026-27 proposed budget for the Lighting District is \$1,538,400, of which, \$1,295,351, has been determined to be of special benefit to properties within the Citywide Lighting District, based on the assessment methodology. However, the District was established to fund only a portion of this amount. As a result, the City will be contributing approximately 60%, or \$934,420, of the total street lighting budget, while the property owners (the “District”) will pay about 40%, or \$603,980, of street lighting costs. The Citywide Lighting District budget for Fiscal Year 2026-27, as proposed, increased by 3.57%, or \$53,000. The increase is due to an increase in electricity costs, vehicle maintenance costs, salaries and wages, and City liability insurance costs.

While increasing the rates is legally defensible to cover the increase in direct benefits to the property owners, the Citywide Lighting District Fund has a balance of \$310,900. This balance is sufficient to cover emergency street lighting repairs and the additional budgeted costs for the year. As such, it is recommended that there be no proposed assessment rate increase for Fiscal Year 2026-27. The annual assessment rate for a single-family property owner in Zone 1 would remain \$23.69, and \$40.33 in Zone 2.

As part of the District formation, an assessment range formula was developed to provide reasonable increases and inflationary adjustments that are associated with providing improvements for the Citywide Lighting District. The maximum rates for the Citywide Lighting District are annually adjusted by an amount not to exceed 3% each Fiscal Year. The adjusted Maximum Assessment Rate is calculated independently of the Citywide Lighting District’s annual budget. Although the assessment range formula allows the City to increase the assessment rate to the allowable maximum, Arcadia has never raised assessment rates to that level. For instance, while the Maximum Assessment Rate formula would allow the rates for a single-family property owner to be raised to \$26.84 in Zone 1, and \$45.63 in Zone 2, the proposed property owners’ assessment rates will not increase and will remain at \$23.69 in Zone 1; and \$40.33 in Zone 2. The applied assessment rates will continue to remain less than the maximum assessment rates that the City is allowed to use.

Using a single-family property as the baseline for the assessment, the table below shows the annual assessment rate levied in Fiscal Year 2025-26, and the proposed Fiscal Year 2026-27 annual assessment rates for Zones 1 and 2:

	<b>FY 25-26 Assessment Rate</b>	<b>FY 26-27 Assessment Rate<sup>1</sup></b>
<b><u>Lighting District Total Budget</u></b>	\$1,485,400	<b>\$1,538,400</b>
<b>Zone 1 (Arterial Lights)</b>	\$23.69	<b>\$23.69</b>
Sparse Lighting	<i>(\$4.74)</i>	<i>(\$4.74)</i>
<b>Zone 2 (Local Lights)</b>	\$40.33	<b>\$40.33</b>
Sparse Lighting	<i>(\$8.07)</i>	<i>(\$8.07)</i>

<sup>1</sup> FY 2026-27 Maximum Assessment Rate for Zone 1 is \$26.84; Zone 2 is \$ 45.63

At the June 16, 2026, City Council Meeting, a public hearing will be conducted to receive public comment regarding the levy and collection of assessments for the District. Fees can only be adopted after the conclusion of the public hearing.

### **ENVIRONMENTAL ANALYSIS**

The proposed action does not constitute a project under the California Environmental Quality Act ("CEQA"), under Section 15061(b)(3) of the CEQA Guidelines, as it can be seen with certainty that it will have no impact on the environment.

### **FISCAL IMPACT**

Fees collected under the Citywide Lighting District will help defray the total maintenance costs of lighting in the subject areas. Upon conclusion of the public hearing and adoption of the engineer's report, a total of \$603,980 will be levied and collected under the Citywide Lighting District, remitted as part of the annual property tax payments. The levy will not exceed the cost of providing the subject services to the areas, nor will the levy exceed the Maximum Assessment Rates allowed. The levy has been set to ensure that the cost to property owners does not exceed the special benefit to each property. Based on the recommended assessments, the City of Arcadia will contribute \$934,420 to the street lighting system in Fiscal Year 2026-27.

### **RECOMMENDATION**

It is recommended that the City Council find that the following resolutions do not constitute a project under the California Environmental Quality Act ("CEQA"); and adopt:

- a. Resolution No. 7690 initiating proceedings for the annual levy and collection of assessments for the Arcadia Citywide Lighting District No. 1, pursuant to the provisions of Part 2 of Division 15 of the California Streets and Highways Code and ordering the preparation of the Engineer's Report.
- b. Resolution No. 7691 approving the preliminary Engineer's Report of Willdan Financial Services for the Arcadia Citywide Lighting District No. 1.

- c. Resolution No. 7692 declaring its intention to levy and collect assessments within the Arcadia Citywide Lighting District No. 1 for Fiscal Year 2026-27 and appointing a time and place for a public hearing.

Approved:



Dominic Lazzaretto  
City Manager

- Attachment No. 1: Resolution No. 7690
- Attachment No. 2: Resolution No. 7691
- Attachment No. 3: Resolution No. 7692

RESOLUTION NO. 7690

A RESOLUTION OF THE CITY COUNCIL OF THE CITY OF ARCADIA, CALIFORNIA, INITIATING PROCEEDINGS FOR THE ANNUAL LEVY AND COLLECTION OF ASSESSMENTS FOR THE ARCADIA CITYWIDE LIGHTING DISTRICT NO. 1, PURSUANT TO THE PROVISIONS OF PART 2 OF DIVISION 15 OF THE CALIFORNIA STREETS AND HIGHWAYS CODE AND ORDERING THE PREPARATION OF THE ENGINEER'S REPORT

WHEREAS, the City Council of the City of Arcadia (the "City"), in Fiscal Year 2010-11, pursuant to the provisions of the Landscaping and Lighting Act of 1972, Part 2 of Division 15 of the Streets and Highways Code of California, beginning with Section 22500 (hereafter referred to as the "1972 Act"), established and thereafter has levied annual assessments for the Arcadia Citywide Lighting District No. 1 (hereinafter referred to as the "District"); and

WHEREAS, the 1972 Act provides for the formation of an assessment district pursuant to Chapter 2 Article 1 of the 1972 Act, and the levy and collection of assessments by the County on behalf of the City pursuant to Chapter 4 Article 2 of the 1972 Act; and

WHEREAS, the City Council has determined that it is necessary and desirable to continue the current levels of maintenance and/or improvements of the District; and

WHEREAS, to maintain such levels, it is necessary to continue the collection of assessments as has occurred in the past fiscal year.

NOW, THEREFORE, THE CITY COUNCIL OF THE CITY OF ARCADIA, CALIFORNIA,  
DOES HEREBY FIND, DETERMINE, AND RESOLVE AS FOLLOWS:

SECTION 1. Pursuant to the provisions of the 1972 Act, the City Council desires to initiate proceedings for the levy and collection of assessments to pay for a portion of the costs for the operation, maintenance, and servicing of public street lighting improvements and appurtenant facilities related thereto during Fiscal Year 2026-27.

SECTION 2. The boundaries of the District are coterminous with the boundaries of the City of Arcadia.

SECTION 3. The City Council has retained Willdan Financial Services as the Engineer of Work (hereinafter referred to as the "Engineer") for the purpose of assisting with the annual levy of the District, including the preparation and filing of the Engineer's Report with the City Clerk in accordance with the 1972 Act.

SECTION 4. The City Council hereby orders Willdan Financial Services to prepare and file with the City Clerk an Engineer's Report establishing the Fiscal Year 2026-27 assessments for the District.

SECTION 5. The City Clerk shall certify to the adoption of this Resolution.

[SIGNATURE ON THE NEXT PAGE]

Passed, approved, and adopted this 2nd day of June, 2026.

  
\_\_\_\_\_  
Mayor of the City of Arcadia

ATTEST:

  
\_\_\_\_\_  
City Clerk

APPROVED AS TO FORM:

  
\_\_\_\_\_  
Michael J. Maurer  
City Attorney

STATE OF CALIFORNIA     )  
COUNTY OF LOS ANGELES ) SS:  
CITY OF ARCADIA         )

I, LINDA RODRIGUEZ, City Clerk of the City of Arcadia, hereby certifies that the foregoing Resolution No. 7690 was passed and adopted by the City Council of the City of Arcadia, signed by the Mayor and attested to by the City Clerk at a regular meeting of said Council held on the 2nd day of June, 2026 and that said Resolution was adopted by the following vote, to wit:

AYES:       Cao, Kwan, Fu, and Cheng

NOES:       None

ABSENT:    None

  
\_\_\_\_\_  
City Clerk of the City of Arcadia

RESOLUTION NO. 7691

A RESOLUTION OF THE CITY COUNCIL OF THE CITY OF ARCADIA, CALIFORNIA, APPROVING THE PRELIMINARY ENGINEER'S REPORT OF WILLDAN FINANCIAL SERVICES FOR THE ARCADIA CITYWIDE LIGHTING DISTRICT NO. 1

WHEREAS, the City Council of the City of Arcadia (the "City"), in Fiscal Year 2010-11, pursuant to the provisions of the Landscaping and Lighting Act of 1972, Part 2 of Division 15 of the Streets and Highways Code of California, beginning with Section 22500 (hereafter referred to as the "1972 Act"), established and thereafter has levied annual assessments for the Arcadia Citywide Lighting District No. 1 (hereinafter referred to as the "District"); and

WHEREAS, the 1972 Act provides for the formation of an assessment district pursuant to Chapter 2 Article 1 of the 1972 Act, and the levy and collection of assessments by the County on behalf of the City pursuant to Chapter 4 Article 2 of the 1972 Act; and

WHEREAS, the City Council, by previous resolution, has ordered Willdan Financial Services as the Engineer of Work (hereinafter referred to as the "Engineer"), in accordance with the 1972 Act, to prepare and file with the City Clerk an Engineer's Report ("Report") establishing Fiscal Year 2026-27 assessments for the District; and

WHEREAS, a Report has been prepared and filed with the City Clerk of the City of Arcadia in accordance with Article 4 of Chapter 1 (Sections 22565 through 22574)

of the 1972 Act, said Report being entitled "City of Arcadia, Arcadia Citywide Lighting District No. 1, Fiscal Year 2026-27 Engineer's Report"; and

WHEREAS, the City Clerk has presented to the City Council said Report as prescribed by Chapter 2, Article 1, Section 22586 of said 1972 Act; and

WHEREAS, the City Council has examined and reviewed the Report as presented and is preliminarily satisfied with the Report, and with each and all of the budget items and documents therein, and that the proposed assessments have been spread in accordance with the special benefits received from the proposed improvements as set forth in said Report.

NOW, THEREFORE, THE CITY COUNCIL OF THE CITY OF ARCADIA,  
CALIFORNIA, DOES HEREBY FIND, DETERMINE, AND RESOLVE AS FOLLOWS:

SECTION 1. RECITALS. The preceding recitals are all true and correct.

SECTION 2. REPORT CONTENT. The Report as presented consists of the following:

2a) Plans and specifications that describe the District and Improvements.

2b) Method of Apportionment that outlines the special benefit conferred on properties within the District from the improvements; and the calculations used to establish each parcel's proportional special benefit assessment for the fiscal year including the establishment of:

- i. Annual assessments for the ongoing maintenance, servicing, and operation of street lighting improvements that provide special benefits to the properties in the District; and
- ii. An Assessment Range Formula that provides for inflationary adjustments to the annual assessment for the ongoing maintenance, servicing, and operation of street lighting improvements, thereby establishing the maximum assessment rate authorized for the fiscal year.

2c) The Budget that outlines the estimated annual expenses to provide and maintain the improvements, including incidental expenses authorized by the 1972 Act.

2d) An Assessment Diagram that identifies the boundaries of the District, the designated zones of benefit, and the associated lots, parcels, and properties included therein.

2e) An Assessment Roll containing the Assessor Parcel Numbers that comprise the District and the proportional assessments for Fiscal Year 2026-27.

SECTION 3. REPORT APPROVAL. The Report, attached hereto as Exhibit "A", is hereby approved and ordered to be filed in the Office of the City Clerk as a permanent record and to remain open to public inspection.

SECTION 4. The City Clerk shall certify to the adoption of this Resolution.

Passed, approved, and adopted this 2nd day of June, 2026.

  
\_\_\_\_\_  
Mayor of the City of Arcadia

ATTEST:

  
\_\_\_\_\_  
City Clerk

APPROVED AS TO FORM:

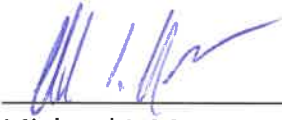
  
\_\_\_\_\_  
Michael J. Maurer  
City Attorney

STATE OF CALIFORNIA     )  
COUNTY OF LOS ANGELES ) SS:  
CITY OF ARCADIA         )

I, LINDA RODRIGUEZ, City Clerk of the City of Arcadia, hereby certifies that the foregoing Resolution No. 7691 was passed and adopted by the City Council of the City of Arcadia, signed by the Mayor and attested to by the City Clerk at a regular meeting of said Council held on the 2nd day of June, 2026 and that said Resolution was adopted by the following vote, to wit:

AYES:       Cao, Kwan, Fu, and Cheng

NOES:       None

ABSENT:     None

  
\_\_\_\_\_  
City Clerk of the City of Arcadia

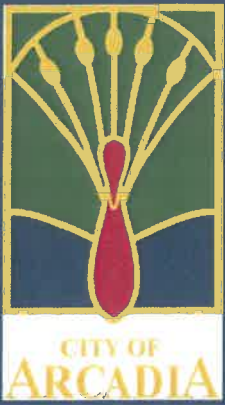

## Exhibit "A"

# City of Arcadia

## ARCADIA CITYWIDE LIGHTING DISTRICT NO. 1 2026/2027 ENGINEER'S REPORT

**Intent Meeting: June 2, 2026**

**Public Hearing: June 16, 2026**

27368 Via Industria  
Suite 200  
Temecula, CA 92590  
T 951.587.3500 | 800.755.6864  
F 951.587.3510 | 888.326.6864

Property Tax Information Line  
T. 866.807.6864

[www.willdan.com](http://www.willdan.com)



**ENGINEER'S REPORT AFFIDAVIT**  
*Establishment of Annual Assessments for the:*  
**Arcadia Citywide Lighting District No. 1**

**City of Arcadia,  
County of Los Angeles, State of California**

This Report describes the Arcadia Citywide Lighting District No. 1 including the improvements, budgets, parcels and assessments to be levied for Fiscal Year 2026/2027, as they existed at the time of the passage of the Resolution of Intention. Reference is hereby made to the Los Angeles County Assessor's maps for a detailed description of the lines and dimensions of parcels within the District. The undersigned respectfully submits the enclosed Report as directed by the City Council.

Dated this \_\_\_\_\_ day of \_\_\_\_\_, 2026.

Willdan Financial Services  
Assessment Engineer  
On Behalf of the City of Arcadia

By: \_\_\_\_\_  
Chonney Gano  
Project Manager

By: \_\_\_\_\_  
Tyrone Peter  
PE # C 81888

# TABLE OF CONTENTS

I.	INTRODUCTION .....	1
II.	PLANS AND SPECIFICATIONS.....	2
A.	DESCRIPTION OF THE DISTRICT.....	2
B.	DESCRIPTION OF IMPROVEMENT AND SERVICES .....	2
III.	METHOD OF APPORTIONMENT.....	5
A.	BENEFIT ANALYSIS.....	5
B.	ASSESSMENT METHODOLOGY.....	8
C.	ASSESSMENT RANGE FORMULA .....	17
IV.	DISTRICT BUDGET .....	18
A.	BUDGET .....	18
B.	PARCEL ASSESSMENT CALCULATION.....	21
V.	DISTRICT DIAGRAM.....	22
VI.	ASSESSMENT ROLL .....	24

## I. INTRODUCTION

---

The Arcadia Citywide Lighting District No. 1 (hereafter referred to as the “District”) was formed in 2010 for the purpose of funding in part, the ongoing operation, maintenance and servicing of public lighting improvements within the City of Arcadia (hereafter referred to as the “City”) based on the proportional special benefits to properties within the City.

The District was formed to levy and collect annual assessments on the County tax rolls to fund such improvements and appurtenant facilities authorized pursuant to the *Landscape and Lighting Act of 1972, Part 2 of Division 15 of the California Streets and Highways Code commencing with §22500* (hereafter referred to as the “1972 Act”). In conjunction with the authority of the 1972 Act, the assessments are calculated in compliance with the substantive and procedural requirements of the *California State Constitution Article XIID* (hereafter referred to as the “California Constitution”).

As part of the District formation, the City conducted a property owner protest ballot proceeding for the new special benefit assessments in accordance with the provisions of Government Code, Section 53753, and the California Constitution. In conjunction with this ballot proceeding, the City Council conducted a public hearing on July 20, 2010 to consider public testimonies, comments and written protests regarding the formation of the District and levy of assessments. Upon conclusion of the July 20, 2010 public hearing, property owner protest ballots received were opened and tabulated. No majority protest existed.

On August 3, 2010, the City Council, by Resolution No. 6737, adopted the Engineer’s Report for the formation of the District, including the assessment diagram; ordered the formation of the District; approved the levy and collection of the assessments commencing in Fiscal Year 2010/2011, approved the assessment range formula as described in the formation Report; and ordered the improvements and services to be made.

This Engineer’s Report (hereafter referred to as “Report”) was prepared in connection with the establishment of the District and the levy and collection of annual special benefit assessments related thereto commencing in Fiscal Year 2010/2011, pursuant to Chapter 1, Article 4 beginning with §22565 of the 1972 Act and the provisions of the California Constitution. Said District shall include all lots and parcels of land within the City at the time this Report was prepared, the boundaries of which are coterminous with the City boundaries.

The word “parcel,” for the purposes of this Report, refers to an individual property assigned its own Assessor’s Parcel Number (APN) by the Los Angeles County Assessor’s Office. The Los Angeles County Auditor/Controller uses Assessor’s Parcel Numbers and specific Fund Numbers to identify properties to be assessed on the tax roll for the special benefit assessments.

## II. PLANS AND SPECIFICATIONS

---

### A. DESCRIPTION OF THE DISTRICT

The territory within the District consists of all lots, parcels of land and subdivisions within the City, the boundaries of which are coterminous with the City's boundaries and the metes and bounds that define the City boundaries are incorporated herein as the metes and bounds of this District. An Assessment Diagram incorporated herein under Part IV of this Report, outlines the boundaries of the District and the Zones therein. This diagram incorporates all lots, parcels and subdivisions of land within the District and Zones as they existed at the time this Report was prepared. The District generally includes all or a portion of the parcels identified on the following Los Angeles County Assessor's Parcel Map Books:

5378;5379;5382;5383;5385;5764;5765;5766;5769;5770;5771;  
 5772;5773;5775;5776;5777;5778;5779;5780;5781;5782;5783;  
 5784;5785;5787;5788;5789;5790;5791;8501;8503;8509;8510;  
 8511;8532;8538;8541;8545;8571;8572;8573;8586;8587

Within the boundaries of the District, two (2) Zones – Zone 01 and Zone 02 – have been established to identify parcels and areas within the District for reasons of separating general benefits from special benefits, and differentiating between special benefits and maintenance costs associated with street lighting along arterial streets versus non-arterial streets. It has been determined that the parcels within these Zones receive differing degrees of special benefits from the improvements and services to be provided by the District.

Zone 01 and Zone 02 were established to incorporate properties that receive direct and particular special benefits from streetlight improvements and services along arterial streets versus street lighting improvements and services that are along non-arterial streets. The two Zones within the District and the improvements and benefits associated with the properties therein are described in more detail in Part III (Method of Apportionment) of this Report.

### B. DESCRIPTION OF IMPROVEMENT AND SERVICES

#### Improvements and Services Authorized by the 1972 Act

As generally defined by the 1972 Act and applicable to this District, the improvements and services and associated assessments may include but are not limited to some or all of the following:

The installation or construction of public lighting facilities;

The installation or construction of any facilities which are appurtenant to any of the foregoing or which are necessary or convenient for the maintenance or servicing thereof, including, but not limited to, grading, clearing, removal of debris, the installation or construction of curbs, gutters, walls, sidewalks, paving, or electrical facilities;

The acquisition of any existing improvement otherwise authorized pursuant to the 1972 Act;

The maintenance or servicing, of any of the foregoing including the furnishing of services and materials for the ordinary and usual maintenance, operation, and servicing of any improvement including but not limited to:

Repair, removal, or replacement of all or any part of any improvements;

The cleaning, sandblasting, and painting of improvements to remove or cover graffiti;

Electric current or other illuminating agent for any public lighting facilities;

The collection and accumulation of funds as reserves for the purpose of ensuing appropriate cash flow for operational activities and long-term maintenance expenses.

Incidental expenses associated with the improvements including, but not limited to:

- o The cost of preparation of this report, including plans, specifications, estimates, diagram, and assessment;
- o The costs of printing, advertising, and the publishing, posting and mailing of notices;
- o Compensation payable to the County for collection of assessments;
- o Compensation of any engineer or attorney employed to render services;
- o Any expenses incidental to the issuance of bonds or notes;
- o Costs associated with the proceedings held for the approval of a new or increased assessment.

Any other expenses are incidental to the construction, installation, or maintenance and servicing of the improvements.

### District Facilities and Improvements

A detailed map and description of the locations and extent of the District’s existing street lighting improvements are on file in the Office of Public Works Services Department, and by reference these documents are made part of this Report. The following table provides a summary of the streetlight inventory within the City at the time this Report was prepared:

**Table 1  
City of Arcadia Streetlight Inventory**

Street Lighting	Edison-Owned Lights	City-Owned Lights	Total Lights
District-wide Streetlights (Arterial Streets)	915	547	1,462
District-wide Streetlights (Local Streets)	1,623	(1) 940	2,563
<b>Total Streetlights</b>	<b>2,538</b>	<b>1,487</b>	<b>4,025</b>

Approximately sixty-three percent (63%) of the streetlights within the District are owned and maintained by Southern California Edison Company. The remaining thirty-seven percent (37%) of the streetlight facilities are owned by the City and are maintained by the City.

The maintenance and servicing of the Southern California Edison Company-owned streetlights is furnished by the Southern California Edison Company or by its successors or assignees. The rates charged by Edison include an Electric Delivery rate which contains the cost of moving energy from the grid to one’s home or business and maintenance cost of the electric lines. SCE also charges Arcadia residents a CCA Cost Responsibility Surcharge which includes PCIA (the rate to recover costs of power purchased before residents joined Clean Power Alliance), a Department of Water Resources Bond Charge to cover the cost of buying power for customers during the energy crisis, and a Competition Transition Charge (non-by-passable charge applicable to all existing and future SCE Bundled Service Customers, all Direct Access Customers, and all Departing Load Customers for recovery of SCE’s transition costs).

The Energy for City-Owned streetlights is procured through the Clean Power Alliance and the rate charged to the City is not regulated and authorized by the CPUC. Clean Power rates are set by the Board of Directors.

While the annual cost of providing the Southern California Edison Company-owned streetlights versus the City-owned streetlights may vary slightly, the difference in annual cost per light is considered negligible and has no bearing on the benefits.

The maintenance, operation and servicing of the District lighting improvements generally includes the furnishing of labor, materials, equipment and electricity for the ordinary and usual maintenance, operation, and servicing of streetlights within the public right-of-ways and easements dedicated to the City. These activities include but are not limited to:

Regular maintenance and servicing the streetlight systems including, cleaning, sandblasting, repainting of poles and equipment to remove or cover graffiti and as needed prevent corrosion; repair or replacement of lighting standards, bulbs and fixtures; and furnishing of electric currents or other illuminating agents.

Periodic repair and rehabilitation of the street lighting system including replacement of old equipment with new or reconditioned equipment; and repair, removal or replacement of related equipment as required including but not limited to lighting fixtures, poles, meters, conduits, electrical cable and relocation of streetlight facilities as necessary including the purchase and installation of related equipment and facilities.

Specifically not included in the District budget and the proportional special benefit assessments is the installation and construction of new streetlights and/or conversion of existing streetlights to decorative streetlights. Such projects and expenditures would be considered Capital Improvement Projects that are beyond the purpose of the assessments for this District. If such projects are needed or desired, the cost of such would require funding from other sources including but not limited to an additional special assessment on the affected properties and/or funds contributed by the City.

### III. METHOD OF APPORTIONMENT

---

Based on the provisions of the 1972 Act and the California Constitution, this section of the Report summarizes an analysis of the general and special benefits provided by the City's existing street lighting improvements and services to be provided by the District; the resulting District structure (zones of benefit); the formulas used to calculate each parcel's proportional special benefit and assessment obligation, including multiplier factor, based on the entirety of the cost of providing the improvements (method of assessment); and the establishment of an inflationary formula for such assessments to address anticipated cost increases due to inflation (assessment range formula).

#### A. BENEFIT ANALYSIS

The 1972 Act permits the establishment of assessment districts by agencies for the purpose of providing certain public improvements, which include but are not limited to the construction, maintenance, operation, and servicing of public street lighting improvements and appurtenant facilities.

The 1972 Act further requires that the cost of these improvements be levied according to benefit rather than assessed value:

*"The net amount to be assessed upon lands within an assessment district may be apportioned by any formula or method which fairly distributes the net amount among all assessable lots or parcels in proportion to the estimated benefits to be received by each such lot or parcel from the improvements."*

In conjunction with the provisions of the 1972 Act, the California Constitution Article XIID addresses several key criteria for the levy of assessments, notably:

Article XIID Section 2d defines District as:

*"District means an area determined by an agency to contain all parcels which will receive a special benefit from a proposed public improvement or property-related service";*

Article XIID Section 2i defines Special Benefit as:

*"Special benefit" means a particular and distinct benefit over and above general benefits conferred on real property located in the district or to the public at large. General enhancement of property value does not constitute "special benefit."*

Article XIID Section 4a defines proportional special benefit assessments as:

*"An agency which proposes to levy an assessment shall identify all parcels which will have a special benefit conferred upon them and upon which an assessment will be imposed. The proportionate special benefit derived by each identified parcel shall be determined in relationship to the entirety of the capital cost of a public improvement, the maintenance and operation expenses of a public improvement, or the cost of the property related service being provided. No assessment shall be imposed on any parcel which exceeds the reasonable cost of the proportional special benefit conferred on that parcel."*

The method of apportionment (method of assessment) established herein is based on the premise that each assessed property receives special benefits from street lighting improvements and services that are funded by such assessments, and the assessment obligation for each parcel reflects that parcel's proportional special benefits as compared to other properties that receive special benefits as outlined in the preceding definitions established in the 1972 Act and the California Constitution.

To identify and determine the proportional special benefit to each parcel within the District, it is necessary to consider the entire scope of the improvements provided as well as the properties that benefit from those improvements. The District's improvements and the associated costs described in this Report, have been carefully reviewed and have been identified and allocated based on a benefit rationale and calculations that proportionally allocate the net cost of only those improvements determined to be of special benefit to properties within the District.

### Zones of Benefit

In an effort to ensure an appropriate allocation of the estimated annual cost to provide the District improvements based on proportional special benefits, this District will be established with benefit zones ("Zones") as authorized pursuant to Chapter 1 Article 4, Section 22574 of the 1972 Act:

*"The diagram and assessment may classify various areas within an assessment district into different zones where, by reason of variations in the nature, location, and extent of the improvements, the various areas will receive differing degrees of benefit from the improvements. A zone shall consist of all territory which will receive substantially the same degree of benefit from the improvements."*

While the California Constitution requires that *"The proportionate special benefit derived by each identified parcel shall be determined in relationship to the entirety of the capital cost of a public improvement or the maintenance and operation expenses of a public improvement..."*; it is reasonable to conclude that street lighting on arterial streets has been installed primarily for the purpose of nighttime traffic illumination and circulation, and will benefit both the community as a whole and the public at large. On the other-hand, local street lighting improvements are not required in all areas of the City, which is evident in the absence of street lighting within certain neighborhoods. Therefore, street lighting along non-arterial streets (local streetlights) provides special benefit to properties fronting these streets and was installed in connection with the development of such properties. However, these improvements are not mutually exclusive or typically isolated to a particular parcel but are rather shared and directly affect entire neighborhoods or groups of parcels. The location and extent of the specific local streetlight improvements in relationship to those neighborhoods or groups of parcels immediately adjacent or in close proximity to those improvements must be considered.

Therefore, as part of this analysis, the District includes two distinct Zones. Zone 1 includes all parcels that specially benefit from the maintenance of street lighting along arterial streets, and Zone 2 includes remaining parcels within the City that specially benefit from maintenance of street lighting along non-arterial streets (local streetlights). The creation of these two zones requires the apportionment of the total maintenance budget between these two zones, which necessitates the need to separately analyze each zone's maintenance costs to determine the portion of each zone's budget (identified in Part III) that is considered to be general benefit versus special benefit.

While the extent and location of local street lighting improvements in the City has typically resulted from property development or the specific needs of nearby properties, arterial streetlight improvements were installed first and foremost to improve the overall safety of the community and traffic circulation, and are more of an indirect result of property development. Therefore, a significant portion of the maintenance costs in Zone 1 is considered general benefit and will not be assessed against parcels within the District.

Based on a report completed by Meyer, Mohaddes Associates, in March 2006, regarding the City's Transportation Impact Fee Program, it is estimated that the number of vehicular trips generated by properties within the City account for approximately 57% of the total daily trips on the City's arterial streets, with 43% being pass-through trips from outside the City. Utilizing this information as part of the analysis for separating general benefits from special benefits, it is reasonable to conclude that 43% of the streetlight improvements and associated costs of the City's arterial streetlights can be identified as general benefit to the public at large. Likewise, it is reasonable to apply this same 43% trip rationale to the vehicular trips generated by properties within the City (57% of the total trips) to establish the general benefits associated with trips generated within the City that are conferred on real property located in the District ( $43\% \times 57\% = 24.5\%$ ). Collectively this would suggest that approximately sixty-eight percent, 67.5% ( $43\% + 24.5\% = 67.5\%$ ) of the maintenance costs in Zone 1 are for general traffic related improvements along the City's arterial streets, which together improve the overall safety of the community at-large, and the properties therein and; therefore, are considered to be a general benefit and will not be assessed.

In reviewing the location and extent of the City's street lighting improvements and the relationship these improvements have to properties within the District, it has been determined that local streetlights (streetlights that are not located on arterial streets) were installed in connection with the development of nearby properties. As such, these local lighting improvements have a direct and particular relationship to, and provide special benefit to, the properties located in close proximity to those street lighting improvements and on those streets. The special benefit affects these properties in a way that is particular and distinct from its effect on other parcels and that real property in general and the public at large do not share. Furthermore, certain areas of the City do not have local street lighting, which provides further confirmation that local street lighting specially benefits properties in close proximity to such local street lighting. Therefore, since certain areas of the City forgo the need of local street lighting, the maintenance costs associated with local street lighting is not considered to be a general benefit.

The District Budget, incorporated herein under Part III of this Report, provides a summary of the total estimated cost of providing the streetlight improvements and the allocation of those costs as general benefit versus special benefit for each Zone of the District. Details regarding the location and extent of the street lighting improvements within the District and the Zones therein are on file in the Office of Public Works Services Department and by reference these documents are made part of this Report. A diagram showing the exterior boundaries of the District and the two Zones therein is attached and incorporated herein under Part IV (District Diagram) of this Report.

## B. ASSESSMENT METHODOLOGY

In order to calculate and identify the proportional special benefit received by each parcel and their proportionate share of the improvement costs it is necessary to consider not only the improvements and services to be provided, but the relationship each parcel has to those improvements as compared to other parcels in the District.

Article XIID Section 4a reads in part:

*“...The proportionate special benefit derived by each identified parcel shall be determined in relationship to the entirety of the capital cost of a public improvement or the maintenance and operation expenses of a public improvement or for the cost of the property related service being provided. No assessment shall be imposed on any parcel which exceeds the reasonable cost of the proportional special benefit conferred on that parcel.”*

Street lighting, like most public improvements, provides varying degrees of benefit (whether they be general or special) based largely on the extent of such improvements, the location of the improvements in relationship to the properties, the specific use and size of each property, and the reason or need for such improvements as it relates to individual properties. In this District these issues are each considered in determining the proportional special benefit to each parcel by the use of benefit zones, the separation of general benefit and special benefit, and County land use designations. The specific use and size of each property is accounted for to reflect each parcel's need for such improvements and its reasonable cost of the proportional special benefit as compared to other properties that benefit from those improvements. Therefore, an equivalent benefit unit methodology is utilized to assess properties accordingly.

### Equivalent Benefit Units

In addition to the use of Zones, the method of apportionment established for this District to reflect the proportional special benefit of each parcel utilizes a weighted methodology of apportionment typically referred to as an Equivalent Benefit Unit (EBU) methodology. This method of apportionment establishes the typical detached single-family home site as the basic unit of assessment. A single-family residential unit is assigned one (1.0) Equivalent Benefit Unit (EBU) and other property types (land uses) are proportionately weighted (weighted EBU) based on a benefit formula that equates each property's specific characteristics and special benefits to that of the single-family residential unit. This proportional weighting may be based on several considerations that may include, but are not limited to: the type of development (land use), development-status (developed versus undeveloped), size of the property (acreage or units), vehicular trip generation, street frontage, densities or other property related factors including any development restrictions or limitations; as well as the density of lighting associated with each property (addressed through the application of a benefit multiplier factor which is discussed in the next section).

For the improvements and assessments outlined in this Report, it has been determined that the most appropriate proportional special benefit calculation for each parcel is reasonably determined by three basic property characteristics:

Land Use — Commercial/Industrial Use; Residential Use, Institutional Use, Vacant Land (Undeveloped Property), Public Property etc.;

**Property Size** — Acreage for non-residential properties; Units for residential properties. Property size (acreage or units) provides a definable and comparative representation of each parcel's proportional special benefit not only to similar types of properties but to other properties as well. The size of a property provides an appropriate and overall reflection of numerous considerations associated with each parcel's special benefits including vehicular trip generation, average street frontage and development densities.

**Lighting Density** — The amount of street lighting within the City is not uniform and varies from one area to the next, ranging from a standard level of street lighting to no street lighting in certain neighborhoods of the City. To account for this varying level of street lighting a benefit multiplier factor is applied, as discussed in the next section of this report entitled "**Benefit Multiplier Factor.**"

The following outlines the special benefits and equivalent benefit unit calculations to be applied to each of the various land use classifications identified for this District to establish each parcel's proportional special benefit compared to other parcels within each respective Zone of the District:

**Single-Family Residential Property** — This land use is defined as a fully subdivided residential home site with a single residential unit developed on the property. The special benefits that local street lighting provides to such properties include, but are not limited to:

Direct and/or ambient lighting of the property and the immediate area (street and sidewalk) providing improved nighttime visibility and safety;

Reduction in property-related crimes (especially vandalism) commonly associated with poorly lighted areas; and

Improved nighttime ingress and egress to the property.

For purposes of establishing the proportional special benefits and equivalent benefit units for other land uses in this District, the single-family residential land use is designated as the basic unit of assessment and shall be assigned 1.000 EBU per parcel (unit).

**Multi-Family Residential & Mixed Use Property** — This land use is defined as a fully subdivided residential parcel that has more than one residential unit developed on the parcel. (This land use includes apartments, duplexes, triplexes, etc., but does not generally include condominiums, town-homes). This land use designation also includes properties identified by the County Assessor's Office as mixed use property for which there is more than one residential unit (known number of residential units) associated with the property and for which the parcel's primary use is residential, but may also include a commercial component or unit associated with that property. The special benefits that local street lighting provides to such properties include, but are not limited to:

Direct and/or ambient lighting of the property and the immediate area (street and sidewalk) providing improved nighttime visibility and safety;

Reduction in property-related crimes (especially vandalism) commonly associated with poorly lighted areas; and

Improved nighttime ingress and egress to the property.

Although multi-family residential properties receive similar special benefits to that of single-family residential property and an appropriate and comparative calculation of proportional special benefits is reasonably reflected by the parcel's total number of residential units, it would not be reasonable to conclude that on a per unit basis, the benefits are equal. Studies have consistently shown that multi-family units impact public infrastructure at reduced levels compared to a single-family residence, which is reflective of their reduced structure size, trip generation and need for various public improvements. Furthermore, as the density (number of units per parcel) increase, the average distance from the streetlight improvements tends to increase and the number of vehicular trips generated tends to decline because the population density per unit tends to decrease (largely because of reduced unit sizes). Based on these considerations, it is reasonable to conclude that the actual number of streetlights per unit is less than that of a single-family residential property and appropriate weighting of the proportional special benefit per unit for multi-family residential properties as compared to a single-family residential is best represented by the following sliding scale: 0.750 EBU per unit for the first 5 units; plus 0.625 EBU per unit for units 6 through 25; plus 0.500 EBU per unit for units 26 through 50; plus 0.375 EBU per unit for units 51 through 100; plus 0.250 EBU per unit for units 101 or above.

**Condominium/Town-home Property** — This land use is defined as a fully subdivided residential condominium or town-home parcel that typically has one residential unit associated with each Assessor's Parcel Number but is part of a multi-unit development for which each condominium or town-home parcel shares or has common interest (common area) with the other residential parcels in that development. The special benefits that local street lighting provides to such properties include, but are not limited to:

Direct and/or ambient lighting of the property and the immediate area (street and sidewalk) providing improved nighttime visibility and safety;

Reduction in property-related crimes (especially vandalism) commonly associated with poorly lighted areas; and

Improved nighttime ingress and egress to the property.

The development attributes of condominiums and town-homes tend to be a blend of the single-family residential and multi-family residential properties. Like multi-family residential properties, individual condominium and town-home units (individual parcels) within such developments may not have actual street frontage where the local streetlight improvements are located, but rather the common area lot which they share has street frontage. (In most cases, each residential unit fronts a private road or driveway that directly accesses the street where the local streetlight improvements are located). Because condominium and town-home properties represent individual residential units that are privately owned, like single-family residential properties these properties tend to be owner occupied with relatively fewer vacancies per unit than multi-family residential properties, which in turn represents greater average trip generation per unit than multi-family residential properties. However, because this property type usually has a much higher development density (greater number of units per acre) than single-family residential properties the actual number of streetlights per unit is clearly less than that of a single-family residential property.

In consideration of the special benefits associated with these properties and the development characteristics discussed above, it has been determined that an appropriate allocation of special benefit for condominiums, town-homes and similar residential properties is best represented by an assignment of 0.750 EBU per unit. (Because these parcels typically represent a single residential unit or small group of units that are each privately owned, no

adjustment for multiple units is applied to this land use as it is for multi-family residential properties).

**Developed Commercial/Industrial Property** — This land use is defined as a developed property with structures (buildings) that is used or may be used for commercial purposes, whether the structures are occupied or not. This land use does not include parcels for which the primary use of the property is considered residential or Hotels and Motels (transient residential). This land use classification includes most types of commercial enterprises including but not limited to commercial retail; food services; banks; shopping centers; recreational facilities; office buildings and professional buildings, as well as industrial properties including service centers; warehousing and manufacturing. This land use classification also includes any parcel that may incorporate a single residential unit, but is also used in whole or in part for commercial purposes. The special benefits that local street lighting provides to such properties include:

Direct and/or ambient lighting of the property and the immediate area (street and sidewalk) providing improved nighttime visibility and safety;

Reduction in property-related crimes (especially vandalism) commonly associated with poorly lighted areas;

Improved nighttime ingress and egress to the property;

Increased accessibility and/or hours of operation that result from adequate nighttime lighting on the streets near or adjacent to the property; and

Greater nighttime visibility of the property and associated business with the property.

The presence of local street lighting or the lack thereof has a direct and distinct impact on commercial/industrial properties and the businesses associated with those properties. Utilizing trip generation data outlined by the Institute of Transportation Engineers Informational Report, Seventh Edition; commercial/industrial properties generate on average approximately four (4) times the daily vehicular trips per acre generated by a typical single-family residential property (9.57 trips per single-family residential unit compared to 42.32 trips per acre for commercial properties). While the actual daily trips generated by a particular commercial/industrial property may be greater or less than this average, it does provide a reasonable indicator of the proportionality of the special benefits associated with local street lighting for such properties. In support of this finding, an analysis of development densities in the City indicates that on average, single-family and condominium developments yield approximately 4.06 residential units per acre.

Although the preceding evaluations suggest that the direct proportional special benefits to commercial/industrial properties are reasonably reflected by an apportionment of 4.000 EBU per acre, because most commercial/industrial parcels represent a separate and independent commercial enterprise or business with immediate proximity to local street lighting, it has been determined that the proportional special benefit for any individual commercial or industrial parcel is at least equal to that of a single-family residential property. Therefore, a commercial/industrial parcel that is less than one-quarter of an acre in size shall be assigned 1.000 EBU (minimum EBU). Likewise, it is reasonable to conclude that there is a limit to the proportional special benefit that any single parcel receives from local streetlights (maximum EBU). In an analysis of the average street frontage and number of lights per acre for various land use classifications, it has been determined that commercial/industrial parcels shall not be assessed for any acreage greater than ten (10.00) acres, which sets the maximum EBU at 40.000 EBU for this land use classification.

**Developed Hotel/Motel Property** — Although Hotel/Motel Properties are certainly viewed as commercial enterprises, these properties have more significant nighttime use and traffic generation than other commercial/industrial properties that results from their transient residential activities. The special benefits that local street lighting provides to such properties include:

Direct and/or ambient lighting of the property and the immediate area (street and sidewalk) providing improved nighttime visibility and safety;

Reduction in property-related crimes (especially vandalism) commonly associated with poorly lighted areas;

Improved nighttime ingress and egress to the property;

Increased use of the property that result from adequate nighttime lighting immediately adjacent to or near the property which is essential to the extended nighttime operation associated with these properties; and

Greater nighttime visibility of the property that improves potential customer attraction thereby increasing business activity and use of the property.

The presence of local street lighting or the lack thereof can have a direct and significant impact on hotel and motel properties because of their heightened nighttime use of the property. To reflect this increased proportional special benefit resulting from higher nighttime use and need for local street lighting as compared to other commercial/ industrial properties, the proportional special benefits and assessments for this land use classification shall be based on 6.000 EBU per acre. As with commercial/industrial properties, minimum and maximum acreage limits shall be applied in calculating each parcel's individual assessment. These acreage limits result in a minimum Equivalent Benefit Unit of 1.500 EBU for parcels less than one-quarter of an acre and a maximum Equivalent Benefit Unit of 60.000 EBU for parcels greater than ten acres.

**Developed Institutional Property** — This land use is defined as developed private properties used for the purposes of public related services or activities, including but not limited to Colleges, Private Schools, Places of Worship, Day Care Centers, Fraternal Organizations, Hospitals, Convalescent or Retirement Homes, or other similar public service or assembly type properties. The special benefits that local street lighting provides to such properties include:

Direct and/or ambient lighting of the property and the immediate area (street and sidewalk) providing improved nighttime visibility and safety;

Reduction in property-related crimes (especially vandalism) commonly associated with poorly lighted areas; and

Improved nighttime ingress and egress to the property.

While properties in this land use classification are generally considered non-residential properties, it has been determined that this land use classification clearly receives less special benefit from local street lighting than commercial/industrial properties based on several considerations: they represent businesses/operations that provide public related or community services (educational, medical care, religious etc.); they are generally non-profit organizations; and they have significantly less nighttime use and associated trip generation. Based on the special benefits that local street lighting provides to such properties and in consideration of their limited nighttime use, the Equivalent Benefit Units applied to these

properties shall be based on 2.000 EBU per acre with the same minimum and maximum acreage limits that are applied to other acreage-based properties. These limits result in a minimum Equivalent Benefit Unit of 0.500 EBU for parcels less than one-quarter of an acre and a maximum Equivalent Benefit Unit of 20.000 EBU for parcels greater than ten acres.

**Developed Public Property** — This land use is defined as developed public or government-owned property used for public related services or activities, including but not limited to city facilities including parks, community centers, fire and police stations, and city offices; county or state offices and facilities; federal, state or county court facilities; US postal service facilities; public schools; public utility facilities or offices; or other similar developed public properties. The special benefits that local street lighting provides to such properties include:

Direct and/or ambient lighting of the property and the immediate area (street and sidewalk) providing improved nighttime visibility and safety;

Reduction in property-related crimes (especially vandalism) commonly associated with poorly lighted areas; and

Improved nighttime ingress and egress to the property.

While many of these properties have the potential to be converted or utilized as commercial or other non-residential enterprises, their purpose and function is specifically for public related services and activities and they generally have no or limited nighttime use and trip generation, which is similar to Institutional properties. Based on the special benefits that local street lighting provides to such properties and in consideration of their limited nighttime use, the Equivalent Benefit Units applied to these properties shall be based on 2.000 EBU per acre with the same minimum and maximum acreage limits that are applied to other acreage-based properties. These limits result in a minimum Equivalent Benefit Unit of 0.500 EBU for parcels less than one-quarter of an acre and a maximum Equivalent Benefit Unit of 20.000 EBU for parcels greater than ten acres.

The County Tax Collector's Office typically identifies these properties as "Non-Taxable" and does not generate tax bills for these properties and as a matter of practical application, the calculated special benefit and proposed assessment obligation for such properties cannot be collected through the secured tax roll in the same manner as other District assessments. Therefore, the only other alternative to the City is the option to direct bill these properties; otherwise, the total assessment amount applied to these properties would not be recovered and would be lost revenue. In any case, the total amount of maintenance cost allocated to these properties is directly related to special benefit received by these properties and may not be reapportioned to any other parcel(s) within the District.

**Parking Lot/Limited Use Property** — This land use classification is applied to developed privately-owned properties that the City considers not to be fully developed commercial/industrial, institutional or residential properties. This land use classification is typically applied to parcels that are identified as parking lots with limited or no buildings; but may also identify parcels that have limited or restricted non-residential use where the typical commercial/industrial or institutional classification is not applicable or appropriate. The special benefits that local street lighting provides to such properties include:

Direct and/or ambient lighting of the property and the immediate area (street and sidewalk) providing improved nighttime visibility and safety

Reduction in property-related crimes (dumping, graffiti, vandalism and loitering) commonly associated with poorly lighted areas;

Improved nighttime ingress and egress to the property; and

Potential increased use and trip generation that result from adequate nighttime lighting which promotes extended hours of operation.

Based on these special benefits and in consideration of use and need for local street lighting, the Equivalent Benefit Units applied to these properties shall be based on 1.000 EBU per acre with the same minimum and maximum acreage limits that are applied to other acreage-based properties. These limits result in a minimum Equivalent Benefit Unit of 0.250 EBU for parcels less than one-quarter of an acre and a maximum Equivalent Benefit Unit of 10.000 EBU for parcels greater than ten acres.

**Vacant Property** — This land use is defined as property that has been identified as undeveloped, but has reasonable development potential (Few or no development restrictions). The special benefits that local street lighting provides to such properties include:

Direct and/or ambient lighting of the property and the immediate area (street and sidewalk) providing improved nighttime visibility and safety; and

Reduction in property-related crimes (dumping, graffiti, vandalism and loitering) commonly associated with poorly lighted areas.

In an evaluation of the special benefits associated this land use as compared to that of developed properties it becomes evident that the proportional special benefits associated with vacant property are clearly less than those associated with developed properties. Although vacant properties derive special benefits from local street lighting, these special benefits are limited to the land (lot) itself. Conversely, approximately half of the direct and immediate special benefits for developed properties are related to the daily use or potential use of that property (specifically nighttime use). Based on these special benefit considerations and the direct advantages of local street lighting, the Equivalent Benefit Units applied to these properties shall be based on 0.500 EBU per acre with the same minimum and maximum acreage limits that are applied to other acreage-based properties. These limits result in a minimum Equivalent Benefit Unit of 0.125 EBU for parcels less than one-quarter of an acre and a maximum Equivalent Benefit Unit of 5.000 EBU for parcels greater than ten acres.

**Exempt Property (Parcel)** — This land use identifies parcels where, for various reasons, it has been determined that the parcel does not and will not receive special benefits from street lighting improvements. This land use classification may include but is not limited to:

Lots or parcels identified as public streets and other roadways;

Dedicated public easements including open space areas, utility rights-of-way, greenbelts, parkways, or other publicly-owned or utility-owned land that serves the community or general public and are not considered or classified as developed public properties; and

Parcels of land that are privately owned, but cannot be developed independently from an adjacent property or is part of a shared interest with other properties, such as common areas, sliver parcels, bifurcated lots or properties with very restrictive potential or use.

Because these properties either provide a public service that is comparable to street lighting or they are dependent on another property or development, these types of parcels have no direct need for street lighting and are considered to receive no special benefits Therefore these parcel shall be exempt from assessment and are assigned 0.0000 EBU. However, these properties shall be reviewed annually by the assessment engineer to confirm the parcel's use.

**Special Case Property** — In many districts where multiple land use classifications are involved, there may be one or more properties where the standard land use classifications do not accurately identify the use and special benefits received from the improvements, or there may be factors related to that particular parcel that should be noted for review in subsequent fiscal years. The following are some examples of properties that may be classified as Special Case properties:

- Example 1: A parcel may be identified as a Vacant Property, however only a small percentage of the parcel's total acreage can actually be developed. In this case, an appropriate calculation would be based on the net acreage that can be utilized rather than the gross acreage of the parcel. Therefore the parcel is identified as a Special Case so that each year the parcel's proportional special benefit and assessment is accurately addressed utilizing the property's net acreage rather than gross acreage.
- Example 2: The use of a particular property and its proportional special benefit is not in question, but there is some characteristic or issue regarding the property that should be noted or reviewed in future years.
- Example 3: The most common reason for identifying a parcel as a Special Case is usually related to development. A property may be identified by the County as Vacant land, but the property is either being developed or has already been developed. Another example would be a property that would normally be identified as Vacant Land, but is being treated as Exempt Property because due to current and temporary development restrictions that will likely change in the future. In this case, this designation serves as a prompt to review the status of that property each year, and if and when the status of that property changes, the land use designation can be appropriately changed.

Therefore, the Equivalent Benefit Units assigned to Special Case Properties will vary depending on the circumstances and reasons for treating each particular property as a Special Case. The Equivalent Benefit Unit(s) assigned to each such parcel may be based on adjusted acreage, units or a combination of those factors. The City and/or the assessment engineer tasked with the administration of the District shall annually review each parcel designated as a Special Case Property and based on that review shall make appropriate adjustments to that property's land use and Equivalent Benefit Unit assignment as warranted.

The following is a summary of property types and the Equivalent Benefit Unit assignments described in the preceding discussion of Equivalent Benefit Units.

**Table 2:  
Equivalent Benefit Unit Assignments**

Land Use	Benefit Unit Calculations		
Single Family Residential Property	1.000	per unit	
Multi-Family Residential & Mixed Use Property	0.750	per unit	(units 1-5)
	0.625	per unit	(units 6-25)
	0.500	per unit	(units 26-50)
	0.375	per unit	(units 51-100)
	0.250	per unit	(units greater than 100)
Condominium/Town-home Property	0.750	per unit	
Developed Commercial/Industrial Property	4.000	per acre	(minimum 1.000 EBU; maximum 40.000 EBU)
Developed Hotel/Motel Property	6.000	per acre	(minimum 1.500 EBU; maximum 60.000 EBU)
Developed Institutional Property	2.000	per acre	(minimum 0.500 EBU; maximum 20.000 EBU)
Developed Public Property	2.000	per acre	(minimum 0.500 EBU; maximum 20.000 EBU)
Parking Lot/Limited Use Property	1.000	per acre	(minimum 0.250 EBU; maximum 10.000 EBU)
Vacant Property	0.500	per acre	(minimum 0.125 EBU; maximum 5.000 EBU)
Exempt Property	0.000	per parcel	
Special Case Property	varied based on circumstances associated with each parcel		

### **Benefit Multiplier Factor**

In addition to the initial assignment of EBUs based on a parcel's land use, number of units, and acreage, a Benefit Multiplier Factor is also employed to account for the varying density levels of street lighting within the City, which ranges from a standard level of street lighting to no street lighting in certain neighborhoods of the City. In addition, the use of a Benefit Multiplier Factor ensures that the differentiation in lighting density is captured as part of the special benefit findings for each parcel. A Benefit Multiplier Factor shall be applied to each parcel's EBU assignment to calculate the final net number of EBUs that will be used to determine the Maximum Assessment Rate per Zone, and each parcel's unique assessment. The following provides a description of the three different Benefit Multiplier Factors of 1.0, 0.20, and 0.00:

#### ***Benefit Multiplier Factor = 1.0***

Parcels within the District that receive direct special benefits from local streetlight improvements that were installed in connection with the development of the parcel or would otherwise have been required or necessary for the development or future development of such property to its full and best use; and the overall proximity and spacing of local street lighting in the area is consistent with the City's typical density and spacing standards. Parcels with a Benefit Multiplier Factor equal to 1.0 may include, but is not limited to:

Parcels that are within 200 feet of a streetlight.

Parcels that are part of a single-family residential subdivision (tract) in which the average distances from a streetlight is less than 200 feet;

Parcels that are part of a residential subdivision other than a single-family residential subdivision (i.e., condominium projects, apartments or other residential properties) in which the street frontage for the development (common area lot or actual parcel) is within 200 feet of a streetlight.

Non-residential properties (parcels or overall developments) that are within 200 feet of a streetlight on a street that is adjacent to, used, or could be used to access the property. These properties include both developed and undeveloped properties.

***Benefit Multiplier Factor = 0.20***

Parcels within the District that receive direct special benefits from local streetlight improvements that were installed in connection with the development of the parcel or were installed specifically for the properties in that area, but the overall density of street lighting is approximately 20% of the standard lighting density, when compared to the lighting density of parcels with a benefit multiplier factor equal to 1.0. Therefore, the Benefit Multiplier Factor for these parcels equals 0.20. Parcels with a Benefit Multiplier Factor equal to 0.20 may include, but is not limited to:

Parcels that are part of a single-family residential subdivision (tract) in which the average distances from a streetlight is greater than 200 feet, but there are streetlights located along the street that the parcel fronts or along adjacent streets within the development (possibly lights on the perimeter of the development). (Note: parcels that are within such subdivisions that may be directly adjacent to or in closer proximity to a specific streetlight shall be assessed the same as other parcels in that subdivision);

Parcels that are part of a residential development other than a single-family residential subdivision (i.e., condominium projects, apartments or similar residential properties) in which the street frontage for the development (common area lot or actual parcel) is within 400 feet of a streetlight, but more than the 200 feet established for Zone 01.

Non-residential properties (parcels or overall developments) that are within 400 feet of a streetlight on a street that is adjacent to, used, or could be used to access the property. These properties include both developed and undeveloped properties.

***Benefit Multiplier Factor = 0.00***

Parcels within the District that have limited or no local streetlight improvements within their immediate proximity shall have a Benefit Multiplier Factor equal to 0.00 applied to their EBU assignment. Therefore, these properties shall not be assessed and, as part of the notice and ballot proceedings being conducted in connection with the formation of the District, the ballots for these properties shall reflect a zero (\$0.00) assessment amount.

## **C. ASSESSMENT RANGE FORMULA**

Pursuant to the California Constitution Article XIID, the imposition of any new or increased assessment requires certain noticing and meeting requirements. However, Proposition 218 Omnibus Implementation Act states that an assessment is not considered an increased assessment if the assessment does not exceed an assessment formula adopted by the City in accordance with Article XIID of the California Constitution.

As part of the District formation and establishment of annual assessments to fund the ongoing operation, maintenance and servicing of those improvements within the District, an

Assessment Range Formula was developed. The purpose of establishing an Assessment Range Formula is to provide for reasonable increases and inflationary adjustment that are inevitably associated with providing such improvements and activities. The Assessment Range Formula is defined by the following:

The “Maximum Rates” for this District shall be annually adjusted by an amount not to exceed three percent (3%) to establish the new Maximum Assessment Rates authorized for the District each fiscal year. (These new rates may be referred to as Adjusted Maximum Assessment Rates).

Beginning in the District’s second fiscal year (Fiscal Year 2011/2012) and each fiscal year thereafter, the Maximum Assessment Rates will be recalculated and new Adjusted Maximum Assessment Rates will be established for the fiscal year utilizing the Assessment Range Formula described above. The Adjusted Maximum Assessment Rates shall be calculated independently of the District’s annual budget and proposed assessments. Any proposed annual assessment (Rate per EBU) less than or equal to the Adjusted Maximum Assessment Rate for each respective Zone shall not be considered an increased assessment.

To impose a new or increased assessment other than the annual inflationary adjustment provided by the preceding Assessment Range Formula, the City must comply with the provisions of the California Constitution Article XIII D Section 4c, that requires a public hearing and certain protest procedures including mailed notice of the public hearing and property owner protest balloting. Property owners, through the balloting process, must approve such a new or increased assessment before that new or increased assessment may be imposed.

## **IV. DISTRICT BUDGET**

---

### **A. BUDGET**

The City’s streetlight maintenance budget identifies an estimate of anticipated annual expenses associated with the ongoing operation, maintenance and servicing of streetlight improvements that includes, but is not limited to maintenance of streetlights and related facilities, energy costs and incidental expenses. The City provided the estimated total annual cost of streetlight maintenance for Fiscal Year 2026/2027, an inventory of arterial streetlights, and the maintenance costs attributable to arterial streetlights. Table 3 provides the City’s streetlight maintenance budget for Fiscal Year 2026/2027 and Table 4 provide a detailed inventory of the arterial streetlights within the City of Arcadia as well as the maintenance cost associated with these arterial streetlights.

**Table 3  
City of Arcadia Streetlight Maintenance Budget**

Description	FY 2026/2027
Salaries & Wages	\$336,100
Supplies	21,700
Contract Services	100,000
Electric	859,000
Vehicle Maintenance	34,100
City Liability Insurance	36,700
City Administration Services	128,000
POB Contribution	22,800
<b>Total</b>	<b>\$1,538,400</b>

**Table 4  
City of Arcadia Arterial Streetlight Maintenance Budget**

Arterial Street	Number of Edison Lights	Number of City Lights	FY 2026/2027
Baldwin	177	107	\$70,435
Colorado	20	6	3,950
Duarte	122	1	658
Foothill	76	17	11,191
Huntington	52	237	156,009
Las Tunas	46	62	40,813
Live Oak	10	37	24,356
Lower Azusa Rd	12	0	0
Michillinda	51	16	10,532
Peck	14	0	0
Santa Anita	271	15	9,874
Second	19	1	658
Sunset	40	16	10,532
Campus	5	32	21,065
<b>Total <sup>(1)</sup></b>	<b>915</b>	<b>547</b>	<b>\$360,072</b>

<sup>(1)</sup>Total may not foot due to rounding.

The budget for the District outlines the overall estimated annual cost to provide the District improvements per Zone, that portion of the costs that are considered to be general benefit and special benefit for each Zone, and the additional funding support from the City to establish the proposed initial maximum assessment rates to be applied to the various parcels within each Zone.

The District partially funds the operation, maintenance and servicing of lighting improvements throughout the City that provide special benefits to properties within the City. The Fiscal Year 2026/2027 District budget is \$1,538,400, of which \$1,295,351 has been determined to be of special benefit to properties within the District based on the assessment methodology. However, the District is being established to fund only a portion of this amount equal to \$603,980. As a matter of policy, the City will contribute the remaining \$691,371 from the general fund and other revenue sources. Therefore, the City's contribution will not only reduce the assessments against the District's affected parcels, but it will further ensure that property owners are not assessed for more than their proportional special benefit.

**Table 5  
City of Arcadia Citywide Lighting District No. 1  
Fiscal Year 2026/2027 Budget**

	Total Budget	Zone 1 Arterial Lights	Zone 2 Local Lights
Arterial Lights	\$360,072	\$360,072	\$0
Local Streetlight Improvements	1,027,528	0	1,027,528
<b>Annual Maintenance Budget</b>	<b>\$1,387,600</b>	<b>\$360,072</b>	<b>\$1,027,528</b>
Administration <sup>(1)</sup>	\$150,800	\$39,132	\$111,668
<b>Total Expense (see table above for breakdown)</b>	<b>\$1,538,400</b>	<b>\$399,204</b>	<b>\$1,139,196</b>
City Contribution for General Benefit (67.5% of Primary) <sup>(2)</sup>	(\$243,049)	(\$243,049)	\$0
<b>Annual Maintenance Budget Less General Benefit <sup>(3)</sup></b>	<b>\$1,295,351</b>	<b>\$156,155</b>	<b>\$1,139,196</b>
<b>City Contribution for Special Benefit Reduction <sup>(3)</sup></b>	<b>(\$691,371)</b>	<b>(\$53,053)</b>	<b>(\$638,318)</b>
<b>BALANCE TO LEVY <sup>(3)</sup></b>	<b>\$603,980</b>	<b>\$103,102</b>	<b>\$500,879</b>
<b>Total Parcels</b>	<b>17,152</b>	<b>2,718</b>	<b>14,434</b>
<b>Parcels Levied</b>	<b>15,213</b>	<b>2,661</b>	<b>12,552</b>
<b>Total EBU Levied</b>	<b>16,771.62</b>	<b>4,352.11</b>	<b>12,419.50</b>
<b>Maximum Rates <sup>(4)</sup></b>		<b>\$26.84</b>	<b>\$45.63</b>
<b>Applied Rates <sup>(4)</sup></b>		<b>\$23.69</b>	<b>\$40.33</b>

<sup>(1)</sup> Administration includes City Administration Services and POB Contribution.

<sup>(2)</sup> The General Benefit contribution applies to Arterial Streetlights only.

<sup>(3)</sup> Totals may not foot due to rounding.

<sup>(4)</sup> The District's Maximum Rates have an annual adjustment not to exceed three percent (3%). Maximum Rates were increased by 3% from the prior fiscal year. The Applied Rates are less than the Maximum Rates. Reference Section III C: Assessment Range Formula.

## B. PARCEL ASSESSMENT CALCULATION

Pursuant to the provisions of the California Constitution, the proportionate special benefit derived by each parcel within the District and its corresponding assessment obligation shall be determined in relationship to the entirety of the capital cost of a public improvement or the maintenance and operation expenses of a public improvement.

The following formulas are used to calculate each parcel's Levy Amount (proportional assessment obligation):

**Step 1:** Based collectively on the preceding discussion and findings, the estimated annual cost to provide the various District improvements have been allocated to each Zone and separated between general benefit and special benefit. Those improvement costs determined to be of general benefit shall not be assessed to properties within each Zone of the District and these costs are deducted from the total budget to establish the improvement costs determined to be of special benefit.

$$\text{Total Zone Budget} - \text{General Benefit Costs} = \text{Total Zone Special Benefit Costs}$$

**Step 2:** The Total Zone Budget minus any additional contributions from the City or other revenue sources establishes the "Balance to Levy" for that Zone. This Balance to Levy amount is the proportionately allocated to each parcel within the Zone based on their calculated EBU.

$$\text{Total Zone Budget} - \text{Additional City Contribution} = \text{Balance to Levy (Zone)}$$

**Step 3:** Each parcel's proportional special benefit is calculated based on the Equivalent Benefit Unit rationale previously discussed:

$$\text{Parcel's Land Use Benefit} \times (\text{Acreage or Units}) \times \text{Benefit Multiplier Factor} = \text{Parcel's EBU}$$

**Step 4:** The total number of Equivalent Benefit Units for the District and each Zone therein is determined by the sum of all individual EBU(s) applied to parcels that receive a special benefit from the improvements. An assessment amount per EBU (Assessment Rate) for each Zone is established by taking the Balance to Levy in that Zone, and dividing that amount by the total number of EBU(s) for that Zone.

$$\text{Balance to Levy} / \text{Total EBU} = \text{Maximum Assessment Rate per EBU (per Zone)}$$

**Step 5:** This Assessment Rate is then applied back to each parcel's individual EBU to determine the parcel's proportionate benefit and assessment obligation.

$$\text{Maximum Assessment Rate per EBU} \times \text{Parcel's EBU} = \text{Parcel's Assessment}$$

## V. DISTRICT DIAGRAM

---

The parcels within the District consist of the lots, parcels and subdivisions of land within the City. The District Diagram identifies the boundaries of the District and the Zones therein, and is based on the Los Angeles County Assessor's Maps, the Los Angeles County Assessor's secured roll information and the street lighting improvements that existed at the time this Report was prepared. The combination of this Diagram and the Assessment Roll outlined in Part IV of this Report; collectively constitute the District's Assessment Diagram.

A copy of the District Diagram is provided on the following page. A full-size copy of this diagram is on file in the Office of Public Works Services Department, and by reference this diagram is made part of this Report.

**ASSESSMENT DIAGRAM**  
 CITY OF ARCADIA, COUNTY OF LOS ANGELES, STATE OF CALIFORNIA

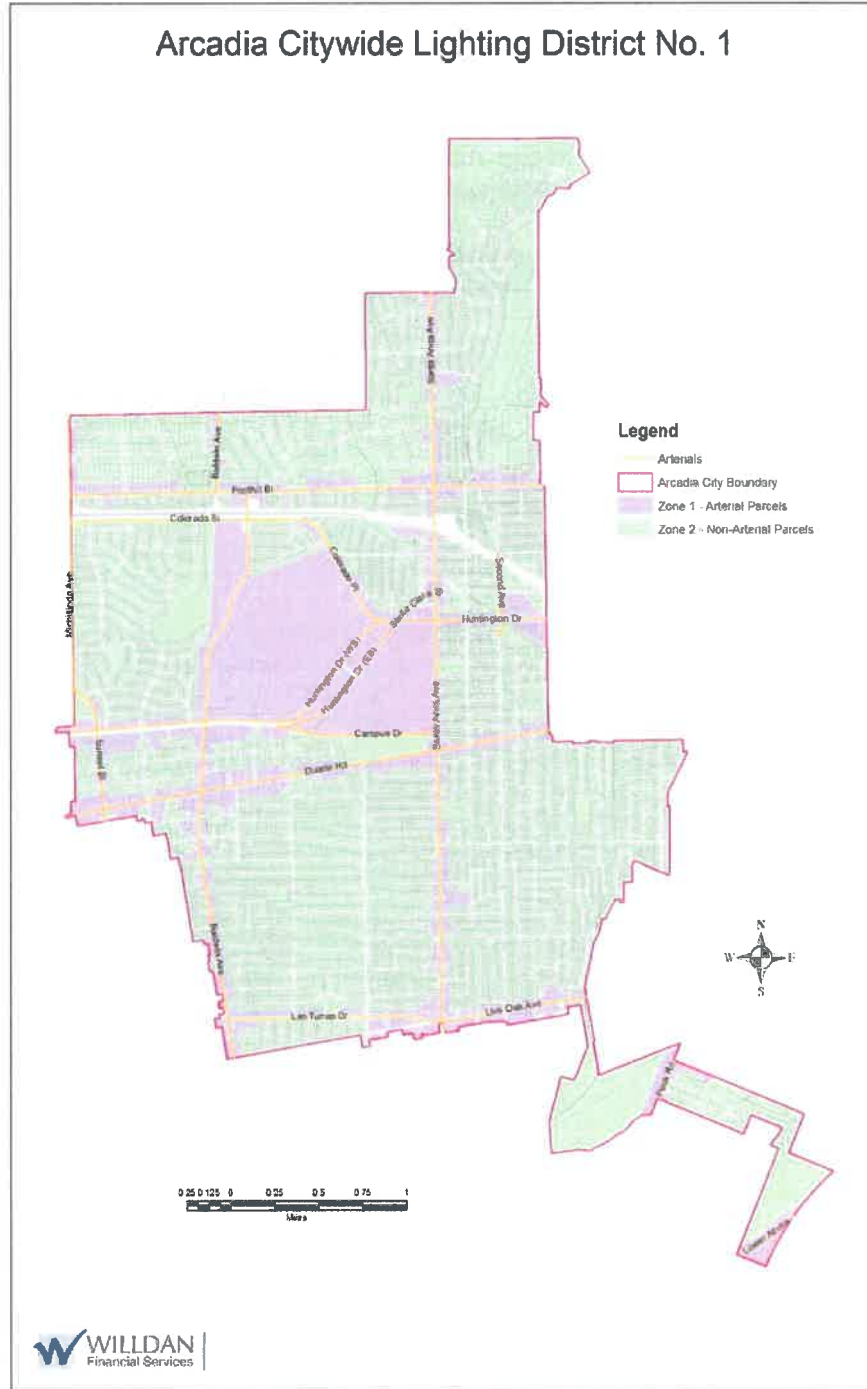

## VI. ASSESSMENT ROLL

Parcel identification for each lot or parcel within the District is based on the District Diagram presented herein and available parcel maps and property data from the Los Angeles County Assessor's Office at the time this Report was prepared. A summary of the parcels to be assessed within this District along with the associated assessment amounts are provided herein. The actual assessment roll listing each of the parcels to be assessed within this District along with their respective assessment amounts have been provided to the City Clerk under a separate cover due to the voluminous number of properties to be assessed.

If any parcel submitted for collection is identified by the County Auditor/Controller to be an invalid parcel number for the fiscal year, a corrected parcel number and/or new parcel numbers will be identified and resubmitted to the County Auditor/Controller. The assessment amount to be levied and collected for the resubmitted parcel or parcels shall be based on the method of apportionment and assessment rates described in this Report as approved by the City Council rather than a proportionate share of the original assessment.

The following is a summary of the land use classifications (parcels) and assessment amounts for the District and each Zone within the District as established by the assessment rates and method of apportionment previously described.

### District-wide

LAND USE	PARCELS LEVIED	FY 2026/2027 EBU <sub>s</sub>	FY 2026/2027 ASSESSMENT
COM	720	1,735.44	\$49,705
CONDO	4,139	3,085.05	106,746
HOT	11	92.16	2,729
INS	55	129.73	3,903
MFR	860	3,555.50	120,873
MIX	9	18.38	460
PKG	116	58.67	1,730
PUB <sup>(1)</sup>	3	3.70	133
SFR	9,247	8,064.20	316,702
SPC	4	3.46	84
VAC	47	17.08	598
SBE	2	8.26	333
<b>GRAND TOTAL <sup>(1)</sup></b>	<b>15,213</b>	<b>16,771.62</b>	<b>\$603,999</b>

<sup>(1)</sup> Totals may not foot due to rounding.

Note: Variance in FY 2026/2027 Assessment amount due to rounding to nearest penny.

### Zone 1

LAND USE	PARCELS LEVIED	FY 2026/2027 EBU's	FY 2026/2027 ASSESSMENT
COM	405	1,219.07	\$28,880
CONDO	1,417	1,062.75	25,180
HOT	6	59.38	1,407
INS	31	79.88	1,892
MFR	187	1,353.48	32,064
MIX	8	16.88	400
PARKING	59	38.20	905
PUB	1	0.94	22
SFR	518	512.80	12,148
SPC	3	3.31	78
VAC	26	5.43	129
<b>GRAND TOTAL <sup>(1)</sup></b>	<b>2,661</b>	<b>4,352.11</b>	<b>\$103,105</b>

<sup>(1)</sup> Totals may not foot due to rounding.

Note: Variance in FY 2026/2027 Assessment amount due to rounding to nearest penny.

### Zone 2

LAND USE	PARCELS LEVIED	FY 2026/2027 EBU's	FY 2026/2027 ASSESSMENT
COM	315	516.37	\$20,825
CONDO	2,722	2,022.30	81,566
HOT	5	32.78	1,322
INS	24	49.85	2,011
MFR	673	2,202.03	88,809
MIX	1	1.50	61
PARKING	57	20.47	826
PUB <sup>(1)</sup>	2	2.75	111
SFR	8,729	7,551.40	304,554
SPC	1	0.15	6
VAC	21	11.65	470
SBE	2	8.26	333
<b>GRAND TOTAL <sup>(1)</sup></b>	<b>12,552</b>	<b>12,419.51</b>	<b>\$500,894</b>

<sup>(1)</sup> Totals may not foot due to rounding.

Note: Variance in FY 2026/2027 Assessment amount due to rounding to nearest penny.

RESOLUTION NO. 7692

A RESOLUTION OF THE CITY COUNCIL OF THE CITY OF ARCADIA, CALIFORNIA, DECLARING ITS INTENTION TO LEVY AND COLLECT ASSESSMENTS WITHIN THE ARCADIA CITYWIDE LIGHTING DISTRICT NO. 1 FOR FISCAL YEAR 2026-27 AND APPOINTING A TIME AND PLACE FOR A PUBLIC HEARING

WHEREAS, the City Council of the City of Arcadia (the "City") pursuant to the provisions of the Landscaping and Lighting Act of 1972, Part 2 of Division 15 of the Streets and Highways Code of California, beginning with Section 22500 (hereafter referred to as the "1972 Act") did by previous Resolution, initiate proceedings for the levy and collection of assessments within the Arcadia Citywide Lighting District No. 1 (hereafter referred to as "District") to fund the on-going maintenance, operation, and servicing of public street lighting improvements and appurtenant facilities related thereto; and

WHEREAS, the City Council has ordered an Engineer's Report (the "Report") for the District for Fiscal Year 2026-27, and said Report has been examined and preliminarily approved by City Council.

NOW, THEREFORE, THE CITY COUNCIL OF THE CITY OF ARCADIA, CALIFORNIA, DOES HEREBY FIND, DETERMINE, AND RESOLVE AS FOLLOWS:

SECTION 1. INTENTION. The City Council hereby declares its intention to levy and collect annual special benefit assessments against parcels of land within the District pursuant to the 1972 Act for Fiscal Year 2026-27.

SECTION 2. TERRITORY. The boundaries of the District are coterminous with the boundaries of the City of Arcadia, within the County of Los Angeles, State of California and include all parcels within said boundaries. Reference is hereby made to the Los Angeles County Assessor's maps for a detailed description of the lines and dimensions of the parcels therein. The District includes two (2) zones of benefit where, by reason of variations in the nature, location, and extent of the improvements, the various areas will receive differing degrees of benefit from the improvements.

SECTION 3. IMPROVEMENTS. The proposed improvements include the operation, maintenance, and servicing of public street lighting improvements and appurtenant facilities in the City of Arcadia that have been determined to be of special benefit to properties within the District. These improvements may include, but are not limited to the materials, equipment, utilities, labor, contract services, and incidental expenses necessary for the ongoing maintenance, operation, and servicing of such improvements and appurtenant facilities. Maps detailing the location and extent of the proposed improvements to be serviced and maintained by the District are on file in the Office of Public Works Services Department of the City of Arcadia and by reference these maps and specifications are made part of this Resolution. Those improvements determined to be of general benefit shall not be assessed against properties in the District.

SECTION 4. ASSESSMENTS. The proposed assessments for the District will provide a funding source to partially support the ongoing annual expenses to maintain service and operate public street lighting improvements that provide special benefits to properties in the District. These proposed assessments are outlined in the Engineer's Report on file at the office of the City Clerk.

SECTION 5. PUBLIC HEARING. The City Council hereby declares its intention to conduct a public hearing concerning the levy and collection of assessments within the District for Fiscal Year 2026-27 in accordance with the 1972 Act and California Constitution, Article XIII D, Section 4.

**Notice is hereby given that a public hearing on these matters will be held by the City Council on Tuesday, June 16, 2026, at 7:00 p.m., or as soon thereafter as feasible in the City Council Chambers, Arcadia City Hall, located at 240 West Huntington Drive, Arcadia, California.**

At the public hearing, all interested persons shall be afforded the opportunity to hear and be heard. Any interested person may also file a written protest with the City Clerk prior to the conclusion of the hearing, or having previously filed such written protest, may file a written withdrawal of that protest. A written protest shall state all grounds of objection and such protest by a property owner within the District shall contain a description sufficient to identify the property owned by such property owner.

Following the public hearing the City Council shall consider and may take actions regarding the assessments for Fiscal Year 2026-27.

SECTION 6. The City Clerk is hereby authorized and directed to give notice of such public hearing as provided by law.

SECTION 7. The City Clerk shall certify to the adoption of this Resolution.

Passed, approved, and adopted this 2nd day of June, 2026.



---

Mayor of the City of Arcadia

ATTEST:



---

City Clerk

APPROVED AS TO FORM:



---

Michael J. Maurer  
City Attorney

STATE OF CALIFORNIA     )  
COUNTY OF LOS ANGELES ) SS:  
CITY OF ARCADIA         )

I, LINDA RODRIGUEZ, City Clerk of the City of Arcadia, hereby certifies that the foregoing Resolution No. 7692 was passed and adopted by the City Council of the City of Arcadia, signed by the Mayor and attested to by the City Clerk at a regular meeting of said Council held on the 2nd day of June, 2026 and that said Resolution was adopted by the following vote, to wit:

AYES:       Cao, Kwan, Fu, and Cheng

NOES:       None

ABSENT:    None

  
\_\_\_\_\_  
City Clerk of the City of Arcadia

**DATE:** June 16, 2026

**TO:** Honorable Mayor and City Council

**FROM:** Paul Cranmer, Public Works Services Director  
By: Briget Arndell, Environmental Services Manager

**SUBJECT:** RESOLUTION NO. 7700 AMENDING THE RESIDENTIAL REFUSE AND RECYCLING AGREEMENT WITH WASTE MANAGEMENT AND SETTING REFUSE AND RECYCLING RATES FOR THE COLLECTION AND DISPOSAL OF SINGLE-FAMILY AND MULTI-FAMILY RESIDENTIAL SOLID WASTE AND RECYCLABLES PURSUANT TO SECTION 5120.7 OF THE ARCADIA MUNICIPAL CODE FOR FISCAL YEARS 2026-27 THROUGH 2030-31

**CEQA: Not a Project**

**Recommendation: Adopt**

### **SUMMARY**

At the April 21, 2026, City Council Meeting, the City Council directed the Public Works Services Department ("PWSD") to follow Proposition 218 balloting procedures for the proposed refuse rate adjustment and set the public hearing for the June 16, 2026, City Council Meeting. The purpose of the public hearing is to allow the public an opportunity to provide comments regarding the proposed refuse rate adjustment.

Upon conclusion of the public hearing, it is recommended that the City Council adopt Resolution No. 7700 amending the Residential Refuse and Recycling Agreement with Waste Management, and setting refuse and recycling rates for the collection and disposal of single-family and multi-family residential solid waste and recyclables pursuant to Section 5120.7 of the Arcadia Municipal Code for Fiscal Years ("FY") 2026-27 through 2030-31.

### **BACKGROUND**

Waste Management ("WM") has been the City's exclusive single-family and multi-family refuse and recycling hauler since 1999 and has consistently provided excellent

service. The current Agreement with WM was executed in March 2009 for a seven-year term, which expired on June 30, 2016. In October 2013, the City Council executed the First Amendment to the Agreement for an additional five years through June 2021. On June 15, 2021, the City Council approved a Second Amendment to the Agreement with WM and a five-year rate adjustment schedule, in accordance with Proposition 218 requirements. The new agreement included an Administrative Fee; new enhanced services, which included two community mulch giveaway events, two community document shredding events, bins for tree trimming, mail-back services for medical sharps waste, and household hazardous waste disposal; fall leaf collection program; miscellaneous debris removal at City-designated sites; trash and recycling collection for five non-City events; and compliance with new laws and regulations. The agreement also included a 10-year term, which expires on June 30, 2031; however, the rates for the final five years of the agreement could not be set at that time due to state limitations.

At the April 7, 2026, City Council Study Session, the PWSD presented a proposed Third Amendment to the WM Agreement. The new agreement includes the following:

- Amendment to the WM contract to reflect a 5-year rate adjustment schedule for FY 2026-27 through 2030-31, in compliance with Proposition 218 requirements;
- Phased two-year labor fee adjustment for FY 2026-27 and FY 2027-28, divided between Single-Family Rates (50%) and Multi-Family Rates (50%);
- Annual Inflationary Adjustment based on the consumer price index and disposal/diversion fee;
- Contamination rates that follow the regional average; and
- An additional community mulch giveaway event provided each fiscal year.

At the April 21, 2026, City Council Meeting, it was recommended that the City Council accept the Third Amendment to the Residential Refuse and Recycling Agreement with WM and the proposed refuse and recycling rates for FY 2026-27 through 2030-31. The City Council accepted staff's recommendation and directed the PWSD to follow Proposition 218 balloting procedures for the proposed refuse rate adjustment, and set the public hearing for the June 16, 2026, City Council Meeting.

**DISCUSSION**

On March 11, 2026, WM submitted a request for a service rate adjustment, which included an increase in labor fees. The labor fees would be phased in over two years for FY 2026-27 and 2027-28, and would be divided evenly, with 50% in Single-Family Rates and 50% in Multi-Family Rates. Furthermore, the service rates include the previously approved annual Rate Adjustment Methodology Formula that is comprised of two indices: a Disposal/Diversion Component and a Service Component. The Disposal/Diversion Component consists of costs for tipping fees charged at landfills for trash, tipping fees charged at composting facilities for green waste/food waste, and recycling fees at processing/recycling facilities. Under the Rate Adjustment Methodology, the Disposal/Diversion Component is given a 40% weight in the calculation of the new rate. The Service Component is based on monthly percent changes in the Consumer Price Index (“CPI”) for Los Angeles-Long Beach-Anaheim, between the current year and the prior year, and is given a 60% weight in the calculation of the new rate. Table 1 shows the percentage breakdown and weighted amount that is accounted for in each index that makes up the rate adjustment for FY 2026-27:

**Table 1: Rate Adjustment Formula**

<b>Rate Component</b>	<b>Weight of Rate</b>	<b>Adjustment due to Change in Indices</b>	<b>Weighted Rate Adjustment Percentage</b>
Disposal/Diversion	40%	3.35%	1.34%
Service	60%	3.21%	1.93%
<b>TOTAL</b>			<b>3.27%</b>

The proposed labor fees account for increased operational collection labor costs of municipal solid waste/trash, totaling \$154,019.79. Table 2 shows the labor fee total divided 50% into Single-Family Rates and 50% Multi-Family Rates, over two years.

**Table 2: Labor Fees Split 50/50**

Single-Family increase per home per month	\$ 0.28
Multi-Family increase per yard per month	\$ 0.09 *

\*Multi-Family rates are calculated per yard on trash services and multiplied by the frequency of pick-ups per week each month (average over 12 months = 4.33).

Should the proposed rates be approved, starting July 1, 2026, there will be an additional \$0.28 reflected in the Single-Family Rates for standard services (one 96-gallon municipal solid waste/trash cart, one 64-gallon recycling cart, and one 96-gallon organics cart), an additional \$1.17 will be reflected in Multi-Family Rates for standard services (one 3-yard municipal solid waste/trash dumpster, one 3-yard recycling dumpster, and one 96-gallon organics cart), and an additional \$0.58 will be reflected in Multi-Family Rates for 3-yard split bin services. The labor fees are only allocated to municipal solid waste/trash (non-recycled waste). A split bin has half municipal solid waste/trash and half dry recycling. As such, only one-half of the split bin is impacted by the labor fee.

Single-Family standard service rates will reflect the 3.27% annual rate adjustment plus the \$0.28 labor fee. The rate will increase by \$1.53 (3.94% total) and will total \$40.36 per month. Multi-Family standard service rates will reflect the 3.27% annual rate adjustment plus the \$1.17 labor fee (\$0.09 x 3-yard bin x the monthly collection frequency, which is about \$4.33 over 12 months). The rate will increase by \$9.17 (3.73% total) and will be \$254.57 per month. Multi-Family 3-yard split bin service rates will reflect the 3.27% annual rate adjustment plus the \$0.58 labor fee (half the \$1.17 labor fee). The rate will increase by \$7.19 (3.54% total) and will be \$210.12 per month. Tables 3 through 5 show the breakdown of proposed service rates for standard services in FY 2026-27.

**Table 3: Single-Family Rates – Standard Services for FY 2026-27**

<b>Effective Date</b> <i>Includes AB 939 flat fee \$0.30</i>	<b>Trash</b> <b>One 96gal cart</b> <b>&amp;</b> <b>Recycling</b> <b>One 64gal cart</b>	<b>Organics</b> <b>One 96gal cart</b>	<b>Labor Fee</b>	<b>TOTAL</b>
<b>FY 2025-26</b> Jul 1, 2025 to Jun 30, 2026 <b>(current rates)</b>	\$26.75	\$12.08	\$0	<b>\$38.83</b>
<b>FY 2026-27</b> Jul 1, 2026 to Jun 30, 2027 <b>(proposed rates)</b>	\$27.61	\$12.47	\$0.28	<b>\$40.36</b> 3.94% increase

**Table 4: Multi-Family Rates – Standard Services for FY 2026-27**

<b>Effective Date</b> <i>Includes AB 939 flat fee \$0.30 per unit</i>	<b>Trash</b> <b>One 3-yard dumpster</b>	<b>Recycling</b> <b>One 3-yard dumpster</b>	<b>Organics</b> <b>One 96gal cart</b>	<b>Calculated Labor Fee</b> <b>\$.09 per yard</b>	<b>TOTAL</b>
<b>FY 2025-26</b> Jul 1, 2025 to Jun 30, 2026 <b>(current rates)</b>	\$159.02	\$67.81	\$18.57	-	<b>\$245.40</b>
<b>FY 2026-27</b> Jul 1, 2026 to Jun 30, 2027 <b>(proposed rates)</b>	\$164.21	\$70.02	\$19.17	\$1.17	<b>\$254.57</b> <i>3.73% increase</i>

**Table 5: Multi-Family Rates – Split Bin Services for FY 2026-27**

<b>Effective Date</b> <i>Includes AB 939 flat fee \$0.30 per unit</i>	<b>Organics</b> <b>One 96gal cart</b>	<b>Split Bin</b> <b>(Trash/Recycling)</b> <b>One 3-yard dumpster</b>	<b>Calculated Labor Fee</b> <b>\$.09 per yard</b>	<b>TOTAL</b>
<b>FY 2025-26</b> Jul 1, 2025 to Jun 30, 2026 <b>(current rates)</b>	\$18.57	\$184.36	-	<b>\$202.93</b>
<b>FY 2026-27</b> Jul 1, 2026 to Jun 30, 2027 <b>(proposed rates)</b>	\$19.17	\$190.37	\$0.58	<b>\$210.12</b> <i>3.54% increase</i>

Effective July 1, 2027, the labor fees will be consistent with FY 2026-27 labor fees. Single-Family Rates would be raised by the annual rate adjustment plus the \$0.28 labor fee for standard services. Multi-Family Rates would be raised by the annual rate adjustment plus \$0.09 per yard, per pickup labor fee for standard services. The Split Bin rate would be raised by the annual rate adjustment plus the \$0.58 labor fee. While the exact rate adjustment for FY 2027-28 cannot be determined at this time, it will follow the annual rate adjustment formula, which is calculated based on the following data:

The current (2026) and prior (2025) year’s costs for:

- Landfill and organic gate rates (disposal);
- Recycling gate rates (disposal);

- Change in combined disposal costs (disposal); and
- 12-month year-over-year average percentage change in the Consumer Price Index for all urban consumers (“CPI-U”) in the garbage and trash index (service).

In FY 2028-29 through FY 2030-31, there will be no labor fees. The annual rate adjustment will go back to using the two indices included in the rate adjustment formula (60% of the Consumer Price Index and 40% of the Disposal/Diversion rate adjustment factor) as approved in the City of Arcadia’s Residential Refuse and Recycling Agreement with WM.

The chart below presents the City of Arcadia’s single-family standard services refuse and recycling rates in comparison to most current single-family standard services rates of those of neighboring jurisdictions. Not all cities shown in the rate comparison table below are WM customers, nor do they provide the same level of service and programs included in the City of Arcadia’s current contract. Cities listed to the left of Arcadia’s (proposed) rate are serviced by other haulers, and the predominant rate adjustment methodology for those cities is CPI+1%. With high inflationary pressures worldwide, those rates are expected to increase significantly in the coming years.

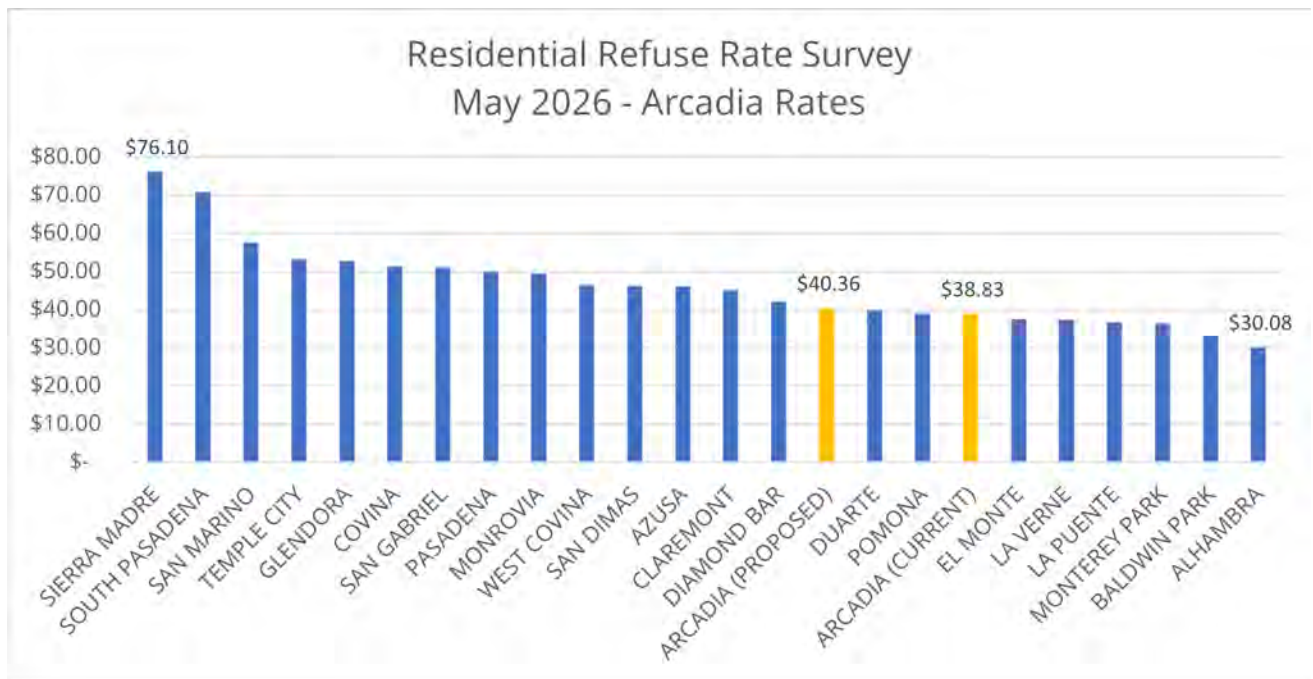

Another thing to note based on the chart above is that the City of Sierra Madre provides all of its residents with a “free” bear resistant bin. Arcadia is occasionally

asked to provide a similar service instead of having interested residents buy them individually. As can be seen with the high cost of Sierra Madre's services, the cost of the required bear bins is reflected in the rate structure.

### **IMPLEMENTATION OF NEW RATES**

In accordance with Proposition 218, the City must engage in a proper voter approval process when increasing refuse rates. These requirements include mailing a written notice detailing the proposed rate increases to all single-family and multi-family residential properties at least 45 days before the proposed Public Hearing.

On April 30, 2026, the PWSD mailed Proposition 218 notices to all single-family and multi-family property owners and/or customers informing them of the proposed refuse and recycling rate adjustment, date of the public hearing, and their right to file a written protest, indicating that written protests must be mailed or personally delivered by Tuesday, June 16, 2026. The notice of Public Hearing was shared in the May City newsletter and posted on the City's website and social media platforms. If there is no majority protest, the City Council can adopt the proposed solid waste rate adjustment schedule for Fiscal Years 2026-27 through 2030-31.

To date, the City has received four written protests. One of the four protests received referenced water and sewer rates and will not be counted as a valid protest. Therefore, only three written protests have been received. One protest was submitted through e-mail and cannot be counted as a valid written protest. Emailed, faxed, or late postmarked protests cannot be accepted.

Even if included in the calculations, the number of protests is significantly below the threshold of 50%. The main issues or concerns received through the protests were general opposition to any increase of rates.

### **ENVIRONMENTAL IMPACT**

The proposed action does not constitute a project under the California Environmental Quality Act ("CEQA"), under Section 15061(b)(3) of the CEQA Guidelines, as it can be seen with certainty that it will have no impact on the environment.

## **FISCAL IMPACT**

Residential refuse and recycling collection and disposal service rates are considered a fee-for-service that is paid directly to the contractor by the residential customer. The City directly receives various fees from WM, which are impacted by the rate adjustment. Those fees include an Administration Fee for annual street pavement maintenance in the amount of \$100,000, plus an annual adjustment consistent with the Consumer Price Index ("CPI"). WM also provides the City with funds to offset the cost of household hazardous waste and sharps collection and disposal. The estimated total for all the fees for FY 2026-27 is \$208,714. These fees will be deposited into the City's Solid Waste Fund.

## **RECOMMENDATION**

It is recommended that the City Council determine that this item is not a project under the California Environmental Quality Act ("CEQA"); and adopt Resolution No. 7700 amending the Residential Refuse and Recycling Agreement with Waste Management and setting refuse and recycling rates for the collection and disposal of single-family and multi-family residential solid waste and recyclables pursuant to Section 5120.7 of the Arcadia Municipal Code for Fiscal Years 2026-27 through 2030-31.

Approved:



Dominic Lazzaretto  
City Manager

Attachments: Resolution No. 7700  
Protest Letters

RESOLUTION NO. 7700

A RESOLUTION OF THE CITY COUNCIL OF THE CITY OF ARCADIA, CALIFORNIA, AMENDING THE RESIDENTIAL REFUSE AND RECYCLING AGREEMENT WITH WASTE MANAGEMENT AND SETTING REFUSE AND RECYCLING RATES FOR THE COLLECTION AND DISPOSAL OF SINGLE-FAMILY AND MULTI-FAMILY RESIDENTIAL SOLID WASTE AND RECYCLABLES PURSUANT TO SECTION 5120.7 OF THE ARCADIA MUNICIPAL CODE FOR FISCAL YEARS 2026-27 THROUGH 2030-31

WHEREAS, pursuant to the Arcadia Municipal Code Section 5120.7, the Arcadia City Council is authorized to fix and determine the rates that may be charged for collecting or removing garbage, refuse or recyclables from any premises in the City; and

WHEREAS, all residential units in the City are required to participate in the City refuse collection service; and

WHEREAS, the franchisee under that certain Residential Refuse and Recycling Agreement dated March 10, 2009, is not authorized to charge or collect any fees or rates other than the fees and rates set forth in this Resolution and the fees and rates shall remain in effect, unless changed by resolution of the City Council of the City of Arcadia; and

WHEREAS, the proposed service rate change was presented to the City Council at its June 16, 2026, regularly schedule City Council meeting; and

WHEREAS, the proposed service rate adjustment includes an increase in labor

fees totaling \$154,019.79, that would be phased in over two years for Fiscal Years (“FY”) 2026-27 and 2027-28 and would be divided evenly, with 50% in Single-Family rates and 50% in Multi-Family rates; and

WHEREAS, the service rates will continue to include an annual rate Adjustment Methodology Formula that includes two indices: a Disposal/Diversion Component and a Service Component; and

WHEREAS, the Disposal/Diversion Component consists of costs for tipping fees charged at landfills for trash, tipping fees charged at composting facilities for green waste/food waste, and recycling fees at processing/recycling facilities; and

WHEREAS, the Disposal/Diversion Component is given a 40% weight in the calculation of the new rate; and

WHEREAS, The Service Component is based on monthly percent changes in the Consumer Price Index (“CPI”) for Los Angeles-Long Beach-Anaheim, between the current year and the prior year, and a 60% weight in the calculation of the new rate; and

WHEREAS, effective July 1, 2026, Single-Family rates will be raised by the annual rate adjustment + the \$0.28 labor fee for standard services; and

WHEREAS, effective July 1, 2026, Multi-Family rates will be raised by the annual rate adjustment + \$0.09 per yard per pickup labor fee for standard services; and

WHEREAS, effective July 1, 2026, the split bin rate will be raised by the annual rate adjustment + the \$0.58 labor fee for trash services; and

WHEREAS, While the exact rate adjustment for FY 2027-28 cannot be determined at this time, it will include the labor fees consistent with FY 2026-27, and will follow the annual rate adjustment formula which is calculated based on the following data:

The current (2026) and prior (2025) year's costs for:

- Landfill and organic gate rates (disposal);
- Recycling gate rates (disposal);
- Change in combined disposal costs (disposal);
- 12-month year-over-year average percentage change in the Consumer Price Index for all urban consumers ("CPI-U") in the garbage and trash index (service); and

WHEREAS, in FY 2028-29 through FY 2030-31, there will be no labor fees, and the rate adjustment formula will go back to using the two indices included in the rate adjustment formula: 60% of the Consumer Price Index and 40% of the Disposal/Diversion rate adjustment factor; and

WHEREAS, Waste Management will add an additional Mulch Giveaway Event as part of this amendment; and

WHEREAS, a public notice concerning said rate change was duly mailed to residents in accordance with Proposition 218 noticing requirements on April 30, 2026, and a duly noticed public hearing concerning said rate adjustments was conducted by the City Council on June 16, 2026, for FY 2026-27 and an automatic annual rate adjustments for FY 2027-28, 2028-29, 2029-30, and 2030-31.

NOW, THEREFORE, THE CITY COUNCIL OF THE CITY OF ARCADIA, CALIFORNIA, DOES HEREBY FIND, DETERMINE AND RESOLVE AS FOLLOWS:

SECTION 1. Commencing July 1, 2026, the monthly rates for Single-Family and Multi-Family Residential Refuse and Recycling collection services for FY 2026-27 shall be those set forth in Exhibit "A" attached hereto.

SECTION 2. All rates set forth in this Resolution shall be reflected on all refuse bills issued on or after July 1, 2026.

SECTION 3. This Resolution provides amendments to the Residential Refuse and Recycling Agreement with Waste Management and sets the refuse and recycling rates for the collection and disposal of Single-Family and Multi-Family residential solid waste and recyclables for FY 2026-27 through 2030-31 set forth in Exhibit "B" attached hereto.

SECTION 3. The City Clerk shall certify the adoption of this Resolution.

Passed, approved, and adopted this 16th day of June, 2026.

\_\_\_\_\_  
Mayor of the City of Arcadia

ATTEST:

\_\_\_\_\_  
City Clerk

APPROVED AS TO FORM:

  
\_\_\_\_\_  
Michael J. Maurer  
City Attorney

Resolution No. 7700 | Exhibit "A" – City of Arcadia Refuse and Recycling Rates 2026-27

City of Arcadia												
Single-Family Rates												
Effective 7/1/2026												
					Total Customer Rate (1 Trash + 1 Recycle + AB939 + Organics)							
Single-Family Trash & Recycling					Total Rate Based on Number of Organics Carts							
Service	Includes (1)	Rate	AB 939	Total Base	1	2	3	4	5	6	7	
Std 35gal Trash	64gal Recyc	\$ 22.74	\$ 0.30	\$ 23.04	\$ 35.51	\$ 40.89	\$ 47.18	\$ 52.97	\$ 59.69	\$ 65.76	\$ 71.85	
Std 64gal Trash	64gal Recyc	\$ 22.74	\$ 0.30	\$ 23.04	\$ 35.51	\$ 40.89	\$ 47.18	\$ 52.97	\$ 59.69	\$ 65.76	\$ 71.85	
Std 96gal Trash	64gal Recyc	\$ 27.59	\$ 0.30	\$ 27.89	\$ 40.36	\$ 45.74	\$ 52.03	\$ 57.82	\$ 64.54	\$ 70.61	\$ 76.70	
Senior 35gal Trash	64gal Recyc	\$ 20.65	\$ 0.30	\$ 20.95	\$ 32.24	\$ 37.01	\$ 42.70	\$ 47.92	\$ 54.03	\$ 59.57	\$ 65.09	
Senior 64 gal Trash	64gal Recyc	\$ 20.65	\$ 0.30	\$ 20.95	\$ 32.24	\$ 37.01	\$ 42.70	\$ 47.92	\$ 54.03	\$ 59.57	\$ 65.09	
Senior 96 gal Trash	64gal Recyc	\$ 25.01	\$ 0.30	\$ 25.31	\$ 36.60	\$ 41.37	\$ 47.06	\$ 52.28	\$ 58.39	\$ 63.93	\$ 69.45	
Backyard Service Std 96gal Tr	64gal Recyc	\$ 82.04	\$ 0.30	\$ 82.34	\$ 94.81	\$ 100.19	\$ 106.48	\$ 112.27	\$ 118.99	\$ 125.06	\$ 131.15	
Backyard Service Senior 96ga	64gal Recyc	\$ 74.96	\$ 0.30	\$ 75.26	\$ 86.55	\$ 91.32	\$ 97.01	\$ 102.23	\$ 108.34	\$ 113.88	\$ 119.40	
Single-Family Organics Carts												
Number of Carts ->												
	1	2	3	4	5	6	7					
64gal Std Organics Cart	\$ 12.47	\$ 17.85	\$ 24.14	\$ 29.93	\$ 36.65	\$ 42.72	\$ 48.81					
64gal Senior Organics Cart	\$ 11.29	\$ 16.06	\$ 21.75	\$ 26.97	\$ 33.08	\$ 38.62	\$ 44.14					
96gal Std Organics Cart	\$ 12.47	\$ 17.85	\$ 24.14	\$ 29.93	\$ 36.65	\$ 42.72	\$ 48.81					
96gal Senior Organics Cart	\$ 11.29	\$ 16.06	\$ 21.75	\$ 26.97	\$ 33.08	\$ 38.62	\$ 44.14					
Single Family Other Additional Fees												
Resume/Reactivation	\$ 53.43											
Bulky Basic, after 4 free	\$ 53.43											
Bulky Senior, after 4 free	\$ 48.09											
Recycling Contamination	\$ 30.00											
Sharps	\$ 46.01											
Bear Unlock Per Cart	\$ 9.46											
3yd Temp Bin, 3 day	\$ 190.01											
3yd Temp Bin, 7 day	\$ 227.82											
3yd Temp Bin, Addl PU	\$ 88.91											
3yd Temp Bin, Daily Rental Over Alloted	\$ 10.73											
Bear Cart Purchase Per Cart	\$ 308.08											
Additional Services												
Service										Addl Trash	Addl Recycle	Extra PU
Std 35gal Trash										\$ 11.63	\$ 11.63	\$ 17.67
Std 64gal Trash										\$ 11.63	\$ 11.63	\$ 17.67
Std 96gal Trash										\$ 14.31	\$ 14.31	\$ 17.95
Senior 35gal Trash										\$ 10.45	\$ 10.45	\$ 16.03
Senior 64 gal Trash										\$ 10.45	\$ 10.45	\$ 16.03
Senior 96 gal Trash										\$ 12.93	\$ 12.93	\$ 16.23
Backyard Service Std 96gal Trash										\$ 21.47	\$ 21.47	\$ 25.44
Backyard Service Senior 96gal Trash										\$ 19.39	\$ 19.39	\$ 22.89
Single-Family Organics Bins with (1) Trash 96gal Cart and (1) Recycling 96gal Cart included												
Standard												
Quantity - Size	Curbside						Backyard					
	1			2			1			2		
	Base	AB939	Total	Base	AB939	Total	Base	AB939	Total	Base	AB939	Total
1 - 1.5 Yard	\$ 187.30	\$ 0.30	\$ 187.60	\$ 348.38	\$ 0.30	\$ 348.68	\$ 225.76	\$ 0.30	\$ 226.06	\$ 419.96	\$ 0.30	\$ 420.26
1 - 3 Yard	\$ 213.05	\$ 0.30	\$ 213.35	\$ 396.31	\$ 0.30	\$ 396.61	\$ 251.02	\$ 0.30	\$ 251.32	\$ 466.93	\$ 0.30	\$ 467.23
Senior												
Quantity - Size	Curbside						Backyard					
	1			2			1			2		
	Base	AB939	Total	Base	AB939	Total	Base	AB939	Total	Base	AB939	Total
1 - 1.5 Yard	\$ 168.69	\$ 0.30	\$ 168.99	\$ 313.83	\$ 0.30	\$ 314.13	\$ 203.21	\$ 0.30	\$ 203.51	\$ 378.03	\$ 0.30	\$ 378.33
1 - 3 Yard	\$ 191.80	\$ 0.30	\$ 192.10	\$ 356.81	\$ 0.30	\$ 357.11	\$ 225.94	\$ 0.30	\$ 226.24	\$ 420.28	\$ 0.30	\$ 420.58
Other Organics Fees												
Reactivation/Cut-Off	\$ 52.42											
Organics Contamination	\$ 30.00											
Locking Lid	\$ 16.94											
Overage	\$ 53.43											

Resolution No. 7700 | Exhibit "A" – City of Arcadia Refuse and Recycling Rates 2026-27

City of Arcadia					
Multi-Family Rates					
Effective 7/1/2026					

**Required: Customers must have trash, recycling and organics service.**  
**Example at Stab service level: (1) 3 Yard Trash Bin 1x/wk \$165.08 + (1) 3 Yard Recycle Bin 1x/wk \$69.72 + (1) Organics Cart 1x/wk \$18.87 + AB939 for 3 units : \$ 254.57**

Multi-Family Trash						
STAB Service	Frequency of Pickup Per Week					
Quantity - Size	1	2	3	4	5	6
1 - 1.5 Yard	\$ 138.15	\$ 276.32	\$ 414.48	\$ 595.40	\$ 690.76	\$ 828.93
2 - 1.5 Yard	\$ 251.30	\$ 502.61	\$ 753.87	\$ 1,005.12	\$ 1,256.47	\$ 1,507.73
3 - 1.5 Yard	\$ 376.94	\$ 753.88	\$ 1,130.84	\$ 1,507.77	\$ 1,884.70	\$ 2,261.67
4 - 1.5 Yard	\$ 502.64	\$ 1,005.22	\$ 1,507.80	\$ 2,010.42	\$ 2,513.06	\$ 3,015.63
5 - 1.5 Yard	\$ 628.25	\$ 1,256.51	\$ 1,884.76	\$ 2,513.07	\$ 3,141.31	\$ 3,769.59
1 - 3 Yard	\$ 165.08	\$ 306.69	\$ 495.17	\$ 660.24	\$ 825.35	\$ 990.38
2 - 3 Yard	\$ 294.98	\$ 613.43	\$ 884.90	\$ 1,179.84	\$ 1,474.83	\$ 1,769.78
3 - 3 Yard	\$ 424.97	\$ 920.08	\$ 1,274.81	\$ 1,699.74	\$ 2,124.69	\$ 2,549.64
4 - 3 Yard	\$ 554.89	\$ 1,226.74	\$ 1,664.58	\$ 2,219.43	\$ 2,774.29	\$ 3,128.79
5 - 3 Yard	\$ 684.86	\$ 1,533.43	\$ 2,054.46	\$ 2,739.22	\$ 3,424.07	\$ 4,108.82
1 - 6 Yard	\$ 309.51	\$ 619.00	\$ 928.47	\$ 1,237.96	\$ 1,547.45	\$ 1,856.97
3- Yard Split Bin Tr	\$ 325.82	\$ 624.58	N/A	N/A	N/A	N/A

Multi-Family Recycling						
STAB Service	Frequency of Pickup Per Week					
Quantity - Size	1	2	3	4	5	6
1 - 96gal	\$ 34.98	\$ 69.97	\$ 104.96	\$ 139.99	\$ 174.95	\$ 209.95
1 - 1.5 Yard	\$ 52.49	\$ 104.96	\$ 157.47	\$ 209.95	\$ 262.43	\$ 314.91
2 - 1.5 Yard	\$ 104.96	\$ 209.95	\$ 314.91	\$ 419.90	\$ 524.85	\$ 629.86
3 - 1.5 Yard	\$ 157.47	\$ 314.91	\$ 472.38	\$ 629.86	\$ 787.32	\$ 944.76
4 - 1.5 Yard	\$ 209.95	\$ 419.90	\$ 629.86	\$ 839.79	\$ 1,049.72	\$ 1,259.66
5 - 1.5 Yard	\$ 262.43	\$ 524.85	\$ 787.32	\$ 1,049.72	\$ 1,312.16	\$ 1,574.58
1 - 3 Yard	\$ 69.72	\$ 139.39	\$ 209.12	\$ 278.83	\$ 348.49	\$ 418.20
2 - 3 Yard	\$ 139.39	\$ 278.83	\$ 418.20	\$ 557.62	\$ 697.02	\$ 836.43
3 - 3 Yard	\$ 209.12	\$ 418.20	\$ 627.33	\$ 836.43	\$ 1,045.51	\$ 1,254.63
4 - 3 Yard	\$ 278.83	\$ 557.62	\$ 836.43	\$ 1,115.23	\$ 1,394.04	\$ 1,672.84
5 - 3 Yard	\$ 348.49	\$ 697.02	\$ 1,045.51	\$ 1,394.04	\$ 1,742.54	\$ 2,091.06

Multi-Family Split Bin - Trash/Recycling						
STAB Service	Frequency of Pickup Per Week					
Quantity - Size	1	2	3	4	5	6
1 - 2 Yard	\$ 180.31	\$ 360.58	\$ 540.89	\$ 763.94	\$ 901.45	\$ 1,081.72
2 - 2 Yard	\$ 335.56	\$ 671.14	\$ 1,006.67	\$ 1,342.19	\$ 1,677.80	\$ 2,013.37
3 - 2 Yard	\$ 503.34	\$ 1,006.68	\$ 1,510.04	\$ 2,013.41	\$ 2,516.74	\$ 3,020.11
4 - 2 Yard	\$ 671.16	\$ 1,342.30	\$ 2,013.43	\$ 2,684.57	\$ 3,355.74	\$ 4,026.86
5 - 2 Yard	\$ 838.92	\$ 1,677.85	\$ 2,516.78	\$ 3,355.75	\$ 4,194.68	\$ 5,033.63
1 - 3 Yard	\$ 190.65	\$ 381.28	\$ 571.95	\$ 805.35	\$ 953.21	\$ 1,143.83
2 - 3 Yard	\$ 356.26	\$ 712.55	\$ 1,068.80	\$ 1,425.02	\$ 1,781.33	\$ 2,137.58
3 - 3 Yard	\$ 534.40	\$ 1,068.81	\$ 1,603.22	\$ 2,137.61	\$ 2,672.01	\$ 3,206.45
4 - 3 Yard	\$ 712.57	\$ 1,425.11	\$ 2,137.64	\$ 2,850.21	\$ 3,562.78	\$ 4,275.28
5 - 3 Yard	\$ 890.67	\$ 1,781.37	\$ 2,672.06	\$ 3,562.79	\$ 4,453.48	\$ 5,344.18
1 - 6 Yard	\$ 234.79	\$ 446.09	\$ 704.29	\$ 939.07	\$ 1,173.85	\$ 1,408.59
2 - 6 Yard	\$ 434.39	\$ 892.25	\$ 1,303.11	\$ 1,737.45	\$ 2,171.85	\$ 2,606.19
3 - 6 Yard	\$ 634.11	\$ 1,338.30	\$ 1,902.11	\$ 2,536.17	\$ 3,170.21	\$ 3,804.27
4 - 6 Yard	\$ 833.71	\$ 1,784.35	\$ 2,500.99	\$ 3,334.66	\$ 4,168.33	\$ 4,801.64
5 - 6 Yard	\$ 1,033.35	\$ 2,230.45	\$ 3,099.98	\$ 4,133.26	\$ 5,166.61	\$ 6,199.86

Resolution No. 7700 | Exhibit "A" – City of Arcadia Refuse and Recycling Rates 2026-27

Required: Customers must have trash, recycling and organics service.

Example at Dismount service level: (1) 3 Yard Trash Bin 1x/wk \$186.03 + (1) 3 Yard Recycle Bin 1x/wk \$78.76 + (1) Organics Cart 1x/wk \$25.67 + AB939 for 3 units \$0.90 = \$ 291.36

**Multi-Family Trash**

DISMOUNT Service Quantity - Size	Frequency of Pickup Per Week					
	1	2	3	4	5	6
1 - 1.5 Yard	\$ 155.67	\$ 311.37	\$ 467.03	\$ 622.73	\$ 778.36	\$ 934.05
2 - 1.5 Yard	\$ 283.20	\$ 566.39	\$ 849.59	\$ 1,132.77	\$ 1,415.94	\$ 1,699.12
3 - 1.5 Yard	\$ 424.76	\$ 849.50	\$ 1,274.27	\$ 1,699.02	\$ 2,123.79	\$ 2,548.47
4 - 1.5 Yard	\$ 566.34	\$ 1,132.74	\$ 1,699.03	\$ 2,265.37	\$ 2,752.60	\$ 3,398.09
5 - 1.5 Yard	\$ 707.95	\$ 1,415.87	\$ 2,123.82	\$ 2,831.75	\$ 3,539.70	\$ 4,247.67
1 - 3 Yard	\$ 186.03	\$ 338.92	\$ 539.03	\$ 718.55	\$ 898.42	\$ 1,078.02
2 - 3 Yard	\$ 327.23	\$ 677.71	\$ 981.53	\$ 1,308.76	\$ 1,635.91	\$ 1,963.13
3 - 3 Yard	\$ 474.65	\$ 1,015.96	\$ 1,423.97	\$ 1,898.65	\$ 2,373.31	\$ 2,847.99
4 - 3 Yard	\$ 622.13	\$ 1,355.54	\$ 1,866.43	\$ 2,488.58	\$ 3,110.75	\$ 3,732.83
5 - 3 Yard	\$ 769.70	\$ 1,694.45	\$ 2,308.95	\$ 3,078.64	\$ 3,848.26	\$ 4,617.92
1 - 6 Yard	\$ 338.59	\$ 677.22	\$ 1,015.73	\$ 1,354.30	\$ 1,692.84	\$ 2,031.45

**Multi-Family Recycling**

DISMOUNT Service Quantity - Size	Frequency of Pickup Per Week					
	1	2	3	4	5	6
1 - 96gal	\$ 39.52	\$ 79.06	\$ 118.59	\$ 158.17	\$ 197.68	\$ 237.22
1 - 1.5 Yard	\$ 59.31	\$ 118.61	\$ 177.92	\$ 237.23	\$ 296.53	\$ 355.87
2 - 1.5 Yard	\$ 118.61	\$ 237.23	\$ 355.87	\$ 474.48	\$ 593.09	\$ 711.71
3 - 1.5 Yard	\$ 177.92	\$ 355.87	\$ 533.79	\$ 711.71	\$ 889.63	\$ 1,067.56
4 - 1.5 Yard	\$ 237.23	\$ 474.48	\$ 711.71	\$ 948.95	\$ 1,186.18	\$ 1,423.42
5 - 1.5 Yard	\$ 296.53	\$ 593.09	\$ 889.63	\$ 1,186.18	\$ 1,482.74	\$ 1,779.30
1 - 3 Yard	\$ 78.76	\$ 157.52	\$ 236.30	\$ 315.06	\$ 393.82	\$ 472.59
2 - 3 Yard	\$ 157.52	\$ 315.06	\$ 472.59	\$ 630.10	\$ 787.64	\$ 945.16
3 - 3 Yard	\$ 236.30	\$ 472.59	\$ 708.86	\$ 945.16	\$ 1,181.45	\$ 1,417.74
4 - 3 Yard	\$ 315.06	\$ 630.10	\$ 945.16	\$ 1,260.22	\$ 1,575.27	\$ 1,890.31
5 - 3 Yard	\$ 393.82	\$ 787.64	\$ 1,181.45	\$ 1,575.27	\$ 1,969.08	\$ 2,362.90

**Multi-Family Split Bin - Trash/Recycling**

DISMOUNT Service Quantity - Size	Frequency of Pickup Per Week					
	1	2	3	4	5	6
1 - 2 Yard	\$ 204.63	\$ 409.27	\$ 613.90	\$ 818.54	\$ 1,023.16	\$ 1,227.80
2 - 2 Yard	\$ 381.11	\$ 762.22	\$ 1,143.33	\$ 1,524.43	\$ 1,905.51	\$ 2,286.62
3 - 2 Yard	\$ 571.64	\$ 1,143.24	\$ 1,714.90	\$ 2,286.53	\$ 2,858.15	\$ 3,429.69
4 - 2 Yard	\$ 762.16	\$ 1,524.39	\$ 2,286.54	\$ 3,048.70	\$ 3,731.75	\$ 4,573.07
5 - 2 Yard	\$ 952.76	\$ 1,905.44	\$ 2,858.20	\$ 3,810.89	\$ 4,763.65	\$ 5,716.41
1 - 3 Yard	\$ 214.98	\$ 429.99	\$ 644.96	\$ 859.95	\$ 1,074.92	\$ 1,289.91
2 - 3 Yard	\$ 401.81	\$ 803.63	\$ 1,205.46	\$ 1,607.24	\$ 2,009.03	\$ 2,410.81
3 - 3 Yard	\$ 602.69	\$ 1,205.36	\$ 1,808.05	\$ 2,410.74	\$ 3,013.43	\$ 3,616.03
4 - 3 Yard	\$ 803.58	\$ 1,607.21	\$ 2,410.75	\$ 3,214.31	\$ 3,938.78	\$ 4,821.53
5 - 3 Yard	\$ 1,004.49	\$ 2,008.95	\$ 3,013.47	\$ 4,017.94	\$ 5,022.45	\$ 6,026.97
1 - 6 Yard	\$ 264.80	\$ 496.45	\$ 775.33	\$ 1,033.60	\$ 1,292.22	\$ 1,550.60
2 - 6 Yard	\$ 484.76	\$ 992.77	\$ 1,454.10	\$ 1,938.86	\$ 2,423.54	\$ 2,908.28
3 - 6 Yard	\$ 710.96	\$ 1,488.54	\$ 2,132.85	\$ 2,843.81	\$ 3,554.77	\$ 4,265.72
4 - 6 Yard	\$ 937.19	\$ 1,985.63	\$ 2,811.59	\$ 3,748.81	\$ 4,686.03	\$ 5,623.15
5 - 6 Yard	\$ 1,163.53	\$ 2,482.09	\$ 3,490.40	\$ 4,653.90	\$ 5,817.36	\$ 6,980.80

Resolution No. 7700 | Exhibit "A" – City of Arcadia Refuse and Recycling Rates 2026-27

<b>Required: Customers must have trash, recycling and organics service.</b>	
<b>Example at Stage service level: (1) 3 Yard Trash Bin 1x/wk \$194.26 + (1) 3 Yard Recycle Bin 1x/wk \$85.71 + (1) Organics Cart 1x/wk \$30.92 + AB939 for 3 units \$0.90 =</b>	<b>\$ 311.79</b>

<b>Multi-Family Trash</b>						
<b>STAGE Service</b>	<b>Frequency of Pickup Per Week</b>					
<b>Quantity - Size</b>	<b>1</b>	<b>2</b>	<b>3</b>	<b>4</b>	<b>5</b>	<b>6</b>
1 - 1.5 Yard	\$ 170.28	\$ 340.63	\$ 510.89	\$ 681.18	\$ 851.49	\$ 1,021.80
2 - 1.5 Yard	\$ 309.80	\$ 619.60	\$ 929.39	\$ 1,239.12	\$ 1,548.91	\$ 1,858.70
3 - 1.5 Yard	\$ 464.71	\$ 929.40	\$ 1,394.05	\$ 1,858.72	\$ 2,323.42	\$ 2,788.09
4 - 1.5 Yard	\$ 619.61	\$ 1,239.14	\$ 1,858.76	\$ 2,478.32	\$ 3,097.96	\$ 3,717.53
5 - 1.5 Yard	\$ 774.47	\$ 1,548.92	\$ 2,323.38	\$ 3,097.89	\$ 3,872.36	\$ 4,646.83
1 - 3 Yard	\$ 194.26	\$ 368.15	\$ 582.96	\$ 777.28	\$ 971.58	\$ 1,165.89
2 - 3 Yard	\$ 358.88	\$ 736.31	\$ 1,078.02	\$ 1,437.39	\$ 1,796.76	\$ 2,156.11
3 - 3 Yard	\$ 524.44	\$ 1,104.43	\$ 1,573.27	\$ 2,097.69	\$ 2,622.10	\$ 3,146.49
4 - 3 Yard	\$ 689.48	\$ 1,472.59	\$ 2,068.50	\$ 2,758.04	\$ 3,447.56	\$ 4,137.07
5 - 3 Yard	\$ 854.51	\$ 1,840.74	\$ 2,563.57	\$ 3,418.07	\$ 4,272.63	\$ 5,127.13
1 - 6 Yard	\$ 367.36	\$ 734.83	\$ 1,102.07	\$ 1,469.42	\$ 1,836.76	\$ 2,204.15

<b>Multi-Family Recycling</b>						
<b>STAGE Service</b>	<b>Frequency of Pickup Per Week</b>					
<b>Quantity - Size</b>	<b>1</b>	<b>2</b>	<b>3</b>	<b>4</b>	<b>5</b>	<b>6</b>
1 - 96gal	\$ 43.01	\$ 86.04	\$ 129.06	\$ 172.14	\$ 215.14	\$ 258.17
1 - 1.5 Yard	\$ 64.55	\$ 129.10	\$ 193.68	\$ 258.25	\$ 322.79	\$ 387.34
2 - 1.5 Yard	\$ 129.10	\$ 258.25	\$ 387.34	\$ 516.47	\$ 645.59	\$ 774.70
3 - 1.5 Yard	\$ 193.68	\$ 387.34	\$ 581.03	\$ 774.70	\$ 968.38	\$ 1,162.04
4 - 1.5 Yard	\$ 258.25	\$ 516.47	\$ 774.70	\$ 1,032.93	\$ 1,291.17	\$ 1,549.39
5 - 1.5 Yard	\$ 322.79	\$ 645.59	\$ 968.38	\$ 1,291.17	\$ 1,613.96	\$ 1,936.73
1 - 3 Yard	\$ 85.71	\$ 171.47	\$ 257.18	\$ 342.94	\$ 428.66	\$ 514.40
2 - 3 Yard	\$ 171.47	\$ 342.94	\$ 514.40	\$ 685.89	\$ 857.34	\$ 1,028.81
3 - 3 Yard	\$ 257.18	\$ 514.40	\$ 771.60	\$ 1,028.81	\$ 1,286.01	\$ 1,543.21
4 - 3 Yard	\$ 342.94	\$ 685.89	\$ 1,028.81	\$ 1,371.73	\$ 1,714.67	\$ 2,057.59
5 - 3 Yard	\$ 428.66	\$ 857.34	\$ 1,286.01	\$ 1,714.67	\$ 2,143.34	\$ 2,572.00

<b>Multi-Family Split Bin - Trash/Recycling</b>						
<b>STAGE Service</b>	<b>Frequency of Pickup Per Week</b>					
<b>Quantity - Size</b>	<b>1</b>	<b>2</b>	<b>3</b>	<b>4</b>	<b>5</b>	<b>6</b>
1 - 2 Yard	\$ 224.48	\$ 449.03	\$ 673.53	\$ 898.03	\$ 1,122.54	\$ 1,347.02
2 - 2 Yard	\$ 418.21	\$ 836.43	\$ 1,254.60	\$ 1,672.78	\$ 2,090.97	\$ 2,509.20
3 - 2 Yard	\$ 627.34	\$ 1,254.62	\$ 1,881.92	\$ 2,509.22	\$ 3,136.53	\$ 3,763.80
4 - 2 Yard	\$ 836.45	\$ 1,672.80	\$ 2,509.25	\$ 3,345.62	\$ 4,182.08	\$ 5,018.46
5 - 2 Yard	\$ 1,045.51	\$ 2,090.98	\$ 3,136.49	\$ 4,182.03	\$ 5,227.52	\$ 6,273.01
1 - 3 Yard	\$ 234.83	\$ 469.74	\$ 704.57	\$ 939.44	\$ 1,174.31	\$ 1,409.14
2 - 3 Yard	\$ 438.92	\$ 877.86	\$ 1,316.72	\$ 1,755.59	\$ 2,194.49	\$ 2,633.40
3 - 3 Yard	\$ 658.38	\$ 1,316.74	\$ 1,975.08	\$ 2,633.43	\$ 3,291.81	\$ 3,950.13
4 - 3 Yard	\$ 877.87	\$ 1,755.61	\$ 2,633.47	\$ 3,511.25	\$ 4,389.12	\$ 5,266.91
5 - 3 Yard	\$ 1,097.27	\$ 2,194.50	\$ 3,291.75	\$ 4,389.06	\$ 5,486.32	\$ 6,583.56
1 - 6 Yard	\$ 280.00	\$ 539.63	\$ 840.16	\$ 1,120.22	\$ 1,400.25	\$ 1,680.28
2 - 6 Yard	\$ 530.35	\$ 1,079.25	\$ 1,592.41	\$ 2,123.24	\$ 2,654.09	\$ 3,184.92
3 - 6 Yard	\$ 781.63	\$ 1,618.83	\$ 2,344.85	\$ 3,126.49	\$ 3,908.10	\$ 4,689.71
4 - 6 Yard	\$ 1,032.43	\$ 2,158.49	\$ 3,097.31	\$ 4,129.78	\$ 5,162.24	\$ 6,194.65
5 - 6 Yard	\$ 1,283.16	\$ 2,698.08	\$ 3,849.57	\$ 5,132.75	\$ 6,415.96	\$ 7,699.14

<b>AB939 Fee, per unit, per month, in additional to the above Trash or Split Bin Rates</b>	\$ 0.30
--	---------

**Multi-Family Organics Cart - STAB**

1 - 96gal, 1x/wk	\$ 18.87
2 - 96gal, 1x/wk	\$ 37.70
3 - 96gal, 1x/wk	\$ 56.57
4 - 96gal, 1x/wk	\$ 75.45
5 - 96gal, 1x/wk	\$ 94.29

**Multi-Family Organics Bin- STAB**

2-Yard 1x/wk	\$ 180.72
2 - Yard 2x/wk	\$ 343.36

**Multi-Family Organics Cart - DISMOUNT**

96gal, 1x/wk	\$ 25.67
2 - 96gal, 1x/wk	\$ 51.35
3 - 96gal, 1x/wk	\$ 77.03
4 - 96gal, 1x/wk	\$ 102.71
5 - 96gal, 1x/wk	\$ 128.39

**Multi-Family Organics Bin - DISMOUNT**

2-Yard 1x/wk	\$ 226.44
2 - Yard 2x/wk	\$ 429.20

**Multi-Family Organics Cart - STAGE**

96gal, 1x/wk	\$ 30.92
2 - 96gal, 1x/wk	\$ 61.85
3 - 96gal, 1x/wk	\$ 92.77
4 - 96gal, 1x/wk	\$ 123.70
5 - 96gal, 1x/wk	\$ 154.64

**Multi-Family Organics Bin - STAGE**

2-Yard 1x/wk	\$ 284.14
2 - Yard 2x/wk	\$ 538.82

**Multi-Family Other Fees**

1.5 Yard Extra PU	\$ 80.89
3 Yard Extra PU	\$ 105.27
6 Yard Split Bin Extra PU	\$ 166.32
Contamination	\$ 30.00
Reactivation/Cut-Off	\$ 52.42
Locking Lid	\$ 16.94
Overage	\$ 71.04

**Exhibit "B"**

**CITY OF ARCADIA  
THIRD AMENDMENT TO  
RESIDENTIAL REFUSE AND RECYCLING AGREEMENT**

This Third Amendment to the Residential Refuse and Recycling Agreement ("Third Amendment") is made and entered into on this, \_\_\_\_\_ day of \_\_\_\_\_, 2026 (the "Effective Date") by and between the CITY OF ARCADIA, a Municipal Corporation, hereinafter referred to as "City", and WASTE MANAGEMENT OF SAN GABRIEL/POMONA VALLEY, hereinafter referred to as "Contractor".

**WHEREAS**, the City is responsible for providing solid waste handling services to its citizens, including source reduction, recycling activities and the collection, transfer, and disposal of solid waste within the City boundaries subject to solid waste handling jurisdiction, as provided in Section 40057 through 40059 of the Public Resources Code (Waste Management Act (the "Act")); and

**WHEREAS**, the purposes of the Act are to promote the reduction, recycling, and reuse of solid waste to the maximum extent feasible in an efficient and cost-effective manner, to improve regulation of landfills, to streamline permitting procedures and to specify the role of local agencies to develop and implement integrated waste management programs, including setting the level of services, charges and the nature, location, and extent of the provision of solid waste handling services; and

**WHEREAS**, the collection of residential solid waste and recycling is crucial to the health, safety, and welfare of the City.

**WHEREAS**, City and Contractor entered into an agreement entitled Residential Refuse and Recycling Agreement dated March 10, 2009 ("Agreement") for the collection of residential solid waste and recyclables in the City; and

**WHEREAS**, City and Contractor entered into an amendment of that Agreement entitled "First Amendment" to the Residential Refuse and Recycling Agreement dated October 16, 2013, whereby term of the Agreement, among other things, was extended through June 30, 2021; and

## **Exhibit "B"**

**WHEREAS**, City and Contractor entered into an amendment of that Agreement entitled "Second Amendment" to the Residential Refuse and Recycling Agreement dated July 1, 2021, whereby term of the Agreement, among other things, was extended through June 30, 2026; and

**WHEREAS**, City and Contractor are entered into an amendment of the Agreement entitled "Third Amendment" to the Residential Refuse and Recycling Agreement dated June 16, 2026, whereby the term of the Agreement, among other things, was extended through June 30, 2031; and

**WHEREAS** the service rates will continue to include an annual rate Adjustment Methodology Formula that includes two indices: a Disposal/Diversion Component and a Service Component; and

**WHEREAS** the Disposal/Diversion Component consists of costs for tipping fees charged at landfills for trash, tipping fees charged at composting facilities for green waste/food waste, and recycling fees at processing/recycling facilities; and

**WHEREAS** the Disposal/Diversion Component is given a 40% weight in the calculation of the new rate; and

**WHEREAS** the Service Component is based on monthly percent changes in the Consumer Price Index ("CPI") for Los Angeles-Long Beach-Anaheim, between the current year and the prior year, and a 60% weight in the calculation of the new rate; and

**WHEREAS**, the proposed service rate adjustment includes an increase in labor fees totaling \$154,019.79, that would be phased in over two years for Fiscal Years ("FY") 2026-27 and 2027-28 and would be divided evenly, with 50% in Single-Family rates and 50% in Multi-Family rates; and

**WHEREAS**, effective July 1, 2026, Single-Family rates will be raised by the annual rate adjustment + the \$0.28 labor fee for standard services; and

**WHEREAS**, effective July 1, 2026, Multi-Family rates will be raised by the annual rate adjustment + \$0.09 per yard per pickup labor fee for standard services; and

**Exhibit "B"**

**WHEREAS**, effective July 1, 2026, the split bin rate will be raised by the annual rate adjustment + the \$0.58 labor fee for trash services; and

**WHEREAS**, in FY 2028-29 through FY 2030-31, there will be no labor fees, and the rate adjustment formula will go back to using the two indices included in the rate adjustment formula: 60% of the Consumer Price Index and 40% of the Disposal/Diversion rate adjustment factor; and

**WHEREAS**, contamination rates must follow the regional average and not the annual rate adjustment formula; and

**WHEREAS**, Contractor will add an additional Mulch Giveaway Event each fiscal year, changing Section B.2.c. of the Agreement to the following: Mulch. Contractor shall provide forty (40) cubic yards of mulch for three City-sponsored events per calendar year; and

**WHEREAS**, as permitted in Section DD of the Agreement, should the City and Contractor desire to extend the term and modify certain performance requirements of the Agreement further, a Fourth Amendment is required before June 30, 2031.

**IN WITNESS WHEREOF**, said City has caused its corporate name and seal to be hereunto subscribed and affixed by the Mayor and City Clerk, both thereunto duly authorized, and said Contractor has hereunto subscribed to his name.

**[SIGNATURES ON NEXT PAGE]**

**Exhibit "B"**

CITY OF ARCADIA  
A Municipal Corporation

Waste Management, INC.

By: \_\_\_\_\_  
Dominic Lazzaretto  
City Manager

By: \_\_\_\_\_  
President's Signature  
Name \_\_\_\_\_

ATTEST:

\_\_\_\_\_  
City Clerk

By: \_\_\_\_\_  
Secretary Signature  
Name \_\_\_\_\_

APPROVED AS TO FORM:

\_\_\_\_\_  
Michael J. Maurer  
City Attorney

Resolution No. 7700 | Exhibit "A" – City of Arcadia Refuse and Recycling Rates 2026-27

City of Arcadia					Total Customer Rate (1 Trash + 1 Recycle + AB939 + Organics)							
Single-Family Rates					Total Rate Based on Number of Organics Carts							
Effective 7/1/2026												
Single-Family Trash & Recycling												
Service	Includes (1)	Rate	AB 939	Total Base	1	2	3	4	5	6	7	
Std 35gal Trash	64gal Recyc	\$ 22.74	\$ 0.30	\$ 23.04	\$ 35.51	\$ 40.89	\$ 47.18	\$ 52.97	\$ 59.69	\$ 65.76	\$ 71.85	
Std 64gal Trash	64gal Recyc	\$ 22.74	\$ 0.30	\$ 23.04	\$ 35.51	\$ 40.89	\$ 47.18	\$ 52.97	\$ 59.69	\$ 65.76	\$ 71.85	
Std 96gal Trash	64gal Recyc	\$ 27.59	\$ 0.30	\$ 27.89	\$ 40.36	\$ 45.74	\$ 52.03	\$ 57.82	\$ 64.54	\$ 70.61	\$ 76.70	
Senior 35gal Trash	64gal Recyc	\$ 20.65	\$ 0.30	\$ 20.95	\$ 32.24	\$ 37.01	\$ 42.70	\$ 47.92	\$ 54.03	\$ 59.57	\$ 65.09	
Senior 64 gal Trash	64gal Recyc	\$ 20.65	\$ 0.30	\$ 20.95	\$ 32.24	\$ 37.01	\$ 42.70	\$ 47.92	\$ 54.03	\$ 59.57	\$ 65.09	
Senior 96 gal Trash	64gal Recyc	\$ 25.01	\$ 0.30	\$ 25.31	\$ 36.60	\$ 41.37	\$ 47.06	\$ 52.28	\$ 58.39	\$ 63.93	\$ 69.45	
Backyard Service Std 96gal Tr	64gal Recyc	\$ 82.04	\$ 0.30	\$ 82.34	\$ 94.81	\$ 100.19	\$ 106.48	\$ 112.27	\$ 118.99	\$ 125.06	\$ 131.15	
Backyard Service Senior 96ga	64gal Recyc	\$ 74.96	\$ 0.30	\$ 75.26	\$ 86.55	\$ 91.32	\$ 97.01	\$ 102.23	\$ 108.34	\$ 113.88	\$ 119.40	
Single-Family Organics Carts												
Number of Carts ->	1	2	3	4	5	6	7					
64gal Std Organics Cart	\$ 12.47	\$ 17.85	\$ 24.14	\$ 29.93	\$ 36.65	\$ 42.72	\$ 48.81					
64gal Senior Organics Cart	\$ 11.29	\$ 16.06	\$ 21.75	\$ 26.97	\$ 33.08	\$ 38.62	\$ 44.14					
96gal Std Organics Cart	\$ 12.47	\$ 17.85	\$ 24.14	\$ 29.93	\$ 36.65	\$ 42.72	\$ 48.81					
96gal Senior Organics Cart	\$ 11.29	\$ 16.06	\$ 21.75	\$ 26.97	\$ 33.08	\$ 38.62	\$ 44.14					
Single Family Other Additional Fees												
Resume/Reactivation	\$ 53.43							Additional Services				
Bulky Basic, after 4 free	\$ 53.43				Service			Addl Trash	Addl Recycle	Extra PU		
Bulky Senior, after 4 free	\$ 48.09				Std 35gal Trash			\$ 11.63	\$ 11.63	\$ 17.67		
Recycling Contamination	\$ 30.00				Std 64gal Trash			\$ 11.63	\$ 11.63	\$ 17.67		
Sharps	\$ 46.01				Std 96gal Trash			\$ 14.31	\$ 14.31	\$ 17.95		
Bear Unlock Per Cart	\$ 9.46				Senior 35gal Trash			\$ 10.45	\$ 10.45	\$ 16.03		
3yd Temp Bin, 3 day	\$ 190.01				Senior 64 gal Trash			\$ 10.45	\$ 10.45	\$ 16.03		
3yd Temp Bin, 7 day	\$ 227.82				Senior 96 gal Trash			\$ 12.93	\$ 12.93	\$ 16.23		
3yd Temp Bin, Addl PU	\$ 88.91				Backyard Service Std 96gal Trash			\$ 21.47	\$ 21.47	\$ 25.44		
3yd Temp Bin, Daily Rental					Backyard Service Senior 96gal Trash			\$ 19.39	\$ 19.39	\$ 22.89		
Over Alloted	\$ 10.73											
Bear Cart Purchase Per Cart	\$ 308.08											
Single-Family Organics Bins with (1) Trash 96gal Cart and (1) Recycling 96gal Cart included												
Standard												
Quantity - Size	Curbside						Backyard					
	1			2			1			2		
	Base	AB939	Total	Base	AB939	Total	Base	AB939	Total	Base	AB939	Total
1 - 1.5 Yard	\$ 187.30	\$ 0.30	\$ 187.60	\$ 348.38	\$ 0.30	\$ 348.68	\$ 225.76	\$ 0.30	\$ 226.06	\$ 419.96	\$ 0.30	\$ 420.26
1 - 3 Yard	\$ 213.05	\$ 0.30	\$ 213.35	\$ 396.31	\$ 0.30	\$ 396.61	\$ 251.02	\$ 0.30	\$ 251.32	\$ 466.93	\$ 0.30	\$ 467.23
Senior												
Quantity - Size	Curbside						Backyard					
	1			2			1			2		
	Base	AB939	Total	Base	AB939	Total	Base	AB939	Total	Base	AB939	Total
1 - 1.5 Yard	\$ 168.69	\$ 0.30	\$ 168.99	\$ 313.83	\$ 0.30	\$ 314.13	\$ 203.21	\$ 0.30	\$ 203.51	\$ 378.03	\$ 0.30	\$ 378.33
1 - 3 Yard	\$ 191.80	\$ 0.30	\$ 192.10	\$ 356.81	\$ 0.30	\$ 357.11	\$ 225.94	\$ 0.30	\$ 226.24	\$ 420.28	\$ 0.30	\$ 420.58
Other Organics Fees												
Reactivation/Cut-Off	\$ 52.42											
Organics Contamination	\$ 30.00											
Locking Lid	\$ 16.94											
Overage	\$ 53.43											

Resolution No. 7700 | Exhibit "A" – City of Arcadia Refuse and Recycling Rates 2026-27

City of Arcadia						
Multi-Family Rates						
Effective 7/1/2026						
Required: Customers must have trash, recycling and organics service.						
Example at Stab service level: (1) 3 Yard Trash Bin 1x/wk \$165.08 + (1) 3 Yard Recycle Bin 1x/wk \$69.72 + (1) Organics Cart 1x/wk \$18.87 + AB939 for 3 units : \$ 254.57						
Multi-Family Trash						
STAB Service	Frequency of Pickup Per Week					
Quantity - Size	1	2	3	4	5	6
1 - 1.5 Yard	\$ 138.15	\$ 276.32	\$ 414.48	\$ 595.40	\$ 690.76	\$ 828.93
2 - 1.5 Yard	\$ 251.30	\$ 502.61	\$ 753.87	\$ 1,005.12	\$ 1,256.47	\$ 1,507.73
3 - 1.5 Yard	\$ 376.94	\$ 753.88	\$ 1,130.84	\$ 1,507.77	\$ 1,884.70	\$ 2,261.67
4 - 1.5 Yard	\$ 502.64	\$ 1,005.22	\$ 1,507.80	\$ 2,010.42	\$ 2,513.06	\$ 3,015.63
5 - 1.5 Yard	\$ 628.25	\$ 1,256.51	\$ 1,884.76	\$ 2,513.07	\$ 3,141.31	\$ 3,769.59
1 - 3 Yard	\$ 165.08	\$ 306.69	\$ 495.17	\$ 660.24	\$ 825.35	\$ 990.38
2 - 3 Yard	\$ 294.98	\$ 613.43	\$ 884.90	\$ 1,179.84	\$ 1,474.83	\$ 1,769.78
3 - 3 Yard	\$ 424.97	\$ 920.08	\$ 1,274.81	\$ 1,699.74	\$ 2,124.69	\$ 2,549.64
4 - 3 Yard	\$ 554.89	\$ 1,226.74	\$ 1,664.58	\$ 2,219.43	\$ 2,774.29	\$ 3,128.79
5 - 3 Yard	\$ 684.86	\$ 1,533.43	\$ 2,054.46	\$ 2,739.22	\$ 3,424.07	\$ 4,108.82
1 - 6 Yard	\$ 309.51	\$ 619.00	\$ 928.47	\$ 1,237.96	\$ 1,547.45	\$ 1,856.97
3- Yard Split Bin Tr	\$ 325.82	\$ 624.58	N/A	N/A	N/A	N/A
Multi-Family Recycling						
STAB Service	Frequency of Pickup Per Week					
Quantity - Size	1	2	3	4	5	6
1 - 96gal	\$ 34.98	\$ 69.97	\$ 104.96	\$ 139.99	\$ 174.95	\$ 209.95
1 - 1.5 Yard	\$ 52.49	\$ 104.96	\$ 157.47	\$ 209.95	\$ 262.43	\$ 314.91
2 - 1.5 Yard	\$ 104.96	\$ 209.95	\$ 314.91	\$ 419.90	\$ 524.85	\$ 629.86
3 - 1.5 Yard	\$ 157.47	\$ 314.91	\$ 472.38	\$ 629.86	\$ 787.32	\$ 944.76
4 - 1.5 Yard	\$ 209.95	\$ 419.90	\$ 629.86	\$ 839.79	\$ 1,049.72	\$ 1,259.66
5 - 1.5 Yard	\$ 262.43	\$ 524.85	\$ 787.32	\$ 1,049.72	\$ 1,312.16	\$ 1,574.58
1 - 3 Yard	\$ 69.72	\$ 139.39	\$ 209.12	\$ 278.83	\$ 348.49	\$ 418.20
2 - 3 Yard	\$ 139.39	\$ 278.83	\$ 418.20	\$ 557.62	\$ 697.02	\$ 836.43
3 - 3 Yard	\$ 209.12	\$ 418.20	\$ 627.33	\$ 836.43	\$ 1,045.51	\$ 1,254.63
4 - 3 Yard	\$ 278.83	\$ 557.62	\$ 836.43	\$ 1,115.23	\$ 1,394.04	\$ 1,672.84
5 - 3 Yard	\$ 348.49	\$ 697.02	\$ 1,045.51	\$ 1,394.04	\$ 1,742.54	\$ 2,091.06
Multi-Family Split Bin - Trash/Recycling						
STAB Service	Frequency of Pickup Per Week					
Quantity - Size	1	2	3	4	5	6
1 - 2 Yard	\$ 180.31	\$ 360.58	\$ 540.89	\$ 763.94	\$ 901.45	\$ 1,081.72
2 - 2 Yard	\$ 335.56	\$ 671.14	\$ 1,006.67	\$ 1,342.19	\$ 1,677.80	\$ 2,013.37
3 - 2 Yard	\$ 503.34	\$ 1,006.68	\$ 1,510.04	\$ 2,013.41	\$ 2,516.74	\$ 3,020.11
4 - 2 Yard	\$ 671.16	\$ 1,342.30	\$ 2,013.43	\$ 2,684.57	\$ 3,355.74	\$ 4,026.86
5 - 2 Yard	\$ 838.92	\$ 1,677.85	\$ 2,516.78	\$ 3,355.75	\$ 4,194.68	\$ 5,033.63
1 - 3 Yard	\$ 190.65	\$ 381.28	\$ 571.95	\$ 805.35	\$ 953.21	\$ 1,143.83
2 - 3 Yard	\$ 356.26	\$ 712.55	\$ 1,068.80	\$ 1,425.02	\$ 1,781.33	\$ 2,137.58
3 - 3 Yard	\$ 534.40	\$ 1,068.81	\$ 1,603.22	\$ 2,137.61	\$ 2,672.01	\$ 3,206.45
4 - 3 Yard	\$ 712.57	\$ 1,425.11	\$ 2,137.64	\$ 2,850.21	\$ 3,562.78	\$ 4,275.28
5 - 3 Yard	\$ 890.67	\$ 1,781.37	\$ 2,672.06	\$ 3,562.79	\$ 4,453.48	\$ 5,344.18
1 - 6 Yard	\$ 234.79	\$ 446.09	\$ 704.29	\$ 939.07	\$ 1,173.85	\$ 1,408.59
2 - 6 Yard	\$ 434.39	\$ 892.25	\$ 1,303.11	\$ 1,737.45	\$ 2,171.85	\$ 2,606.19
3 - 6 Yard	\$ 634.11	\$ 1,338.30	\$ 1,902.11	\$ 2,536.17	\$ 3,170.21	\$ 3,804.27
4 - 6 Yard	\$ 833.71	\$ 1,784.35	\$ 2,500.99	\$ 3,334.66	\$ 4,168.33	\$ 4,801.64
5 - 6 Yard	\$ 1,033.35	\$ 2,230.45	\$ 3,099.98	\$ 4,133.26	\$ 5,166.61	\$ 6,199.86

Resolution No. 7700 | Exhibit “A” – City of Arcadia Refuse and Recycling Rates 2026-27

Required: Customers must have trash, recycling and organics service.

Example at Dismount service level: (1) 3 Yard Trash Bin 1x/wk \$186.03 + (1) 3 Yard Recycle Bin 1x/wk \$78.76 + (1) Organics Cart 1x/wk \$25.67 + AB939 for 3 units \$0.90 = \$ 291.36

**Multi-Family Trash**

DISMOUNT Service	Frequency of Pickup Per Week					
Quantity - Size	1	2	3	4	5	6
1 - 1.5 Yard	\$ 155.67	\$ 311.37	\$ 467.03	\$ 622.73	\$ 778.36	\$ 934.05
2 - 1.5 Yard	\$ 283.20	\$ 566.39	\$ 849.59	\$ 1,132.77	\$ 1,415.94	\$ 1,699.12
3 - 1.5 Yard	\$ 424.76	\$ 849.50	\$ 1,274.27	\$ 1,699.02	\$ 2,123.79	\$ 2,548.47
4 - 1.5 Yard	\$ 566.34	\$ 1,132.74	\$ 1,699.03	\$ 2,265.37	\$ 2,752.60	\$ 3,398.09
5 - 1.5 Yard	\$ 707.95	\$ 1,415.87	\$ 2,123.82	\$ 2,831.75	\$ 3,539.70	\$ 4,247.67
1 - 3 Yard	\$ 186.03	\$ 338.92	\$ 539.03	\$ 718.55	\$ 898.42	\$ 1,078.02
2 - 3 Yard	\$ 327.23	\$ 677.71	\$ 981.53	\$ 1,308.76	\$ 1,635.91	\$ 1,963.13
3 - 3 Yard	\$ 474.65	\$ 1,015.96	\$ 1,423.97	\$ 1,898.65	\$ 2,373.31	\$ 2,847.99
4 - 3 Yard	\$ 622.13	\$ 1,355.54	\$ 1,866.43	\$ 2,488.58	\$ 3,110.75	\$ 3,732.83
5 - 3 Yard	\$ 769.70	\$ 1,694.45	\$ 2,308.95	\$ 3,078.64	\$ 3,848.26	\$ 4,617.92
1 - 6 Yard	\$ 338.59	\$ 677.22	\$ 1,015.73	\$ 1,354.30	\$ 1,692.84	\$ 2,031.45

**Multi-Family Recycling**

DISMOUNT Service	Frequency of Pickup Per Week					
Quantity - Size	1	2	3	4	5	6
1 - 96gal	\$ 39.52	\$ 79.06	\$ 118.59	\$ 158.17	\$ 197.68	\$ 237.22
1 - 1.5 Yard	\$ 59.31	\$ 118.61	\$ 177.92	\$ 237.23	\$ 296.53	\$ 355.87
2 - 1.5 Yard	\$ 118.61	\$ 237.23	\$ 355.87	\$ 474.48	\$ 593.09	\$ 711.71
3 - 1.5 Yard	\$ 177.92	\$ 355.87	\$ 533.79	\$ 711.71	\$ 889.63	\$ 1,067.56
4 - 1.5 Yard	\$ 237.23	\$ 474.48	\$ 711.71	\$ 948.95	\$ 1,186.18	\$ 1,423.42
5 - 1.5 Yard	\$ 296.53	\$ 593.09	\$ 889.63	\$ 1,186.18	\$ 1,482.74	\$ 1,779.30
1 - 3 Yard	\$ 78.76	\$ 157.52	\$ 236.30	\$ 315.06	\$ 393.82	\$ 472.59
2 - 3 Yard	\$ 157.52	\$ 315.06	\$ 472.59	\$ 630.10	\$ 787.64	\$ 945.16
3 - 3 Yard	\$ 236.30	\$ 472.59	\$ 708.86	\$ 945.16	\$ 1,181.45	\$ 1,417.74
4 - 3 Yard	\$ 315.06	\$ 630.10	\$ 945.16	\$ 1,260.22	\$ 1,575.27	\$ 1,890.31
5 - 3 Yard	\$ 393.82	\$ 787.64	\$ 1,181.45	\$ 1,575.27	\$ 1,969.08	\$ 2,362.90

**Multi-Family Split Bin - Trash/Recycling**

DISMOUNT Service	Frequency of Pickup Per Week					
Quantity - Size	1	2	3	4	5	6
1 - 2 Yard	\$ 204.63	\$ 409.27	\$ 613.90	\$ 818.54	\$ 1,023.16	\$ 1,227.80
2 - 2 Yard	\$ 381.11	\$ 762.22	\$ 1,143.33	\$ 1,524.43	\$ 1,905.51	\$ 2,286.62
3 - 2 Yard	\$ 571.64	\$ 1,143.24	\$ 1,714.90	\$ 2,286.53	\$ 2,858.15	\$ 3,429.69
4 - 2 Yard	\$ 762.16	\$ 1,524.39	\$ 2,286.54	\$ 3,048.70	\$ 3,731.75	\$ 4,573.07
5 - 2 Yard	\$ 952.76	\$ 1,905.44	\$ 2,858.20	\$ 3,810.89	\$ 4,763.65	\$ 5,716.41
1 - 3 Yard	\$ 214.98	\$ 429.99	\$ 644.96	\$ 859.95	\$ 1,074.92	\$ 1,289.91
2 - 3 Yard	\$ 401.81	\$ 803.63	\$ 1,205.46	\$ 1,607.24	\$ 2,009.03	\$ 2,410.81
3 - 3 Yard	\$ 602.69	\$ 1,205.36	\$ 1,808.05	\$ 2,410.74	\$ 3,013.43	\$ 3,616.03
4 - 3 Yard	\$ 803.58	\$ 1,607.21	\$ 2,410.75	\$ 3,214.31	\$ 3,938.78	\$ 4,821.53
5 - 3 Yard	\$ 1,004.49	\$ 2,008.95	\$ 3,013.47	\$ 4,017.94	\$ 5,022.45	\$ 6,026.97
1 - 6 Yard	\$ 264.80	\$ 496.45	\$ 775.33	\$ 1,033.60	\$ 1,292.22	\$ 1,550.60
2 - 6 Yard	\$ 484.76	\$ 992.77	\$ 1,454.10	\$ 1,938.86	\$ 2,423.54	\$ 2,908.28
3 - 6 Yard	\$ 710.96	\$ 1,488.54	\$ 2,132.85	\$ 2,843.81	\$ 3,554.77	\$ 4,265.72
4 - 6 Yard	\$ 937.19	\$ 1,985.63	\$ 2,811.59	\$ 3,748.81	\$ 4,686.03	\$ 5,623.15
5 - 6 Yard	\$ 1,163.53	\$ 2,482.09	\$ 3,490.40	\$ 4,653.90	\$ 5,817.36	\$ 6,980.80

Resolution No. 7700 | Exhibit “A” – City of Arcadia Refuse and Recycling Rates 2026-27

Required: Customers must have trash, recycling and organics service.

Example at Stage service level: (1) 3 Yard Trash Bin 1x/wk \$194.26 + (1) 3 Yard Recycle Bin 1x/wk \$85.71 + (1) Organics Cart 1x/wk \$30.92 + AB939 for 3 units \$0.90 = \$ 311.79

**Multi-Family Trash**

STAGE Service	Frequency of Pickup Per Week					
Quantity - Size	1	2	3	4	5	6
1 - 1.5 Yard	\$ 170.28	\$ 340.63	\$ 510.89	\$ 681.18	\$ 851.49	\$ 1,021.80
2 - 1.5 Yard	\$ 309.80	\$ 619.60	\$ 929.39	\$ 1,239.12	\$ 1,548.91	\$ 1,858.70
3 - 1.5 Yard	\$ 464.71	\$ 929.40	\$ 1,394.05	\$ 1,858.72	\$ 2,323.42	\$ 2,788.09
4 - 1.5 Yard	\$ 619.61	\$ 1,239.14	\$ 1,858.76	\$ 2,478.32	\$ 3,097.96	\$ 3,717.53
5 - 1.5 Yard	\$ 774.47	\$ 1,548.92	\$ 2,323.38	\$ 3,097.89	\$ 3,872.36	\$ 4,646.83
1 - 3 Yard	\$ 194.26	\$ 368.15	\$ 582.96	\$ 777.28	\$ 971.58	\$ 1,165.89
2 - 3 Yard	\$ 358.88	\$ 736.31	\$ 1,078.02	\$ 1,437.39	\$ 1,796.76	\$ 2,156.11
3 - 3 Yard	\$ 524.44	\$ 1,104.43	\$ 1,573.27	\$ 2,097.69	\$ 2,622.10	\$ 3,146.49
4 - 3 Yard	\$ 689.48	\$ 1,472.59	\$ 2,068.50	\$ 2,758.04	\$ 3,447.56	\$ 4,137.07
5 - 3 Yard	\$ 854.51	\$ 1,840.74	\$ 2,563.57	\$ 3,418.07	\$ 4,272.63	\$ 5,127.13
1 - 6 Yard	\$ 367.36	\$ 734.83	\$ 1,102.07	\$ 1,469.42	\$ 1,836.76	\$ 2,204.15

**Multi-Family Recycling**

STAGE Service	Frequency of Pickup Per Week					
Quantity - Size	1	2	3	4	5	6
1 - 96gal	\$ 43.01	\$ 86.04	\$ 129.06	\$ 172.14	\$ 215.14	\$ 258.17
1 - 1.5 Yard	\$ 64.55	\$ 129.10	\$ 193.68	\$ 258.25	\$ 322.79	\$ 387.34
2 - 1.5 Yard	\$ 129.10	\$ 258.25	\$ 387.34	\$ 516.47	\$ 645.59	\$ 774.70
3 - 1.5 Yard	\$ 193.68	\$ 387.34	\$ 581.03	\$ 774.70	\$ 968.38	\$ 1,162.04
4 - 1.5 Yard	\$ 258.25	\$ 516.47	\$ 774.70	\$ 1,032.93	\$ 1,291.17	\$ 1,549.39
5 - 1.5 Yard	\$ 322.79	\$ 645.59	\$ 968.38	\$ 1,291.17	\$ 1,613.96	\$ 1,936.73
1 - 3 Yard	\$ 85.71	\$ 171.47	\$ 257.18	\$ 342.94	\$ 428.66	\$ 514.40
2 - 3 Yard	\$ 171.47	\$ 342.94	\$ 514.40	\$ 685.89	\$ 857.34	\$ 1,028.81
3 - 3 Yard	\$ 257.18	\$ 514.40	\$ 771.60	\$ 1,028.81	\$ 1,286.01	\$ 1,543.21
4 - 3 Yard	\$ 342.94	\$ 685.89	\$ 1,028.81	\$ 1,371.73	\$ 1,714.67	\$ 2,057.59
5 - 3 Yard	\$ 428.66	\$ 857.34	\$ 1,286.01	\$ 1,714.67	\$ 2,143.34	\$ 2,572.00

**Multi-Family Split Bin - Trash/Recycling**

STAGE Service	Frequency of Pickup Per Week					
Quantity - Size	1	2	3	4	5	6
1 - 2 Yard	\$ 224.48	\$ 449.03	\$ 673.53	\$ 898.03	\$ 1,122.54	\$ 1,347.02
2 - 2 Yard	\$ 418.21	\$ 836.43	\$ 1,254.60	\$ 1,672.78	\$ 2,090.97	\$ 2,509.20
3 - 2 Yard	\$ 627.34	\$ 1,254.62	\$ 1,881.92	\$ 2,509.22	\$ 3,136.53	\$ 3,763.80
4 - 2 Yard	\$ 836.45	\$ 1,672.80	\$ 2,509.25	\$ 3,345.62	\$ 4,182.08	\$ 5,018.46
5 - 2 Yard	\$ 1,045.51	\$ 2,090.98	\$ 3,136.49	\$ 4,182.03	\$ 5,227.52	\$ 6,273.01
1 - 3 Yard	\$ 234.83	\$ 469.74	\$ 704.57	\$ 939.44	\$ 1,174.31	\$ 1,409.14
2 - 3 Yard	\$ 438.92	\$ 877.86	\$ 1,316.72	\$ 1,755.59	\$ 2,194.49	\$ 2,633.40
3 - 3 Yard	\$ 658.38	\$ 1,316.74	\$ 1,975.08	\$ 2,633.43	\$ 3,291.81	\$ 3,950.13
4 - 3 Yard	\$ 877.87	\$ 1,755.61	\$ 2,633.47	\$ 3,511.25	\$ 4,389.12	\$ 5,266.91
5 - 3 Yard	\$ 1,097.27	\$ 2,194.50	\$ 3,291.75	\$ 4,389.06	\$ 5,486.32	\$ 6,583.56
1 - 6 Yard	\$ 280.00	\$ 539.63	\$ 840.16	\$ 1,120.22	\$ 1,400.25	\$ 1,680.28
2 - 6 Yard	\$ 530.35	\$ 1,079.25	\$ 1,592.41	\$ 2,123.24	\$ 2,654.09	\$ 3,184.92
3 - 6 Yard	\$ 781.63	\$ 1,618.83	\$ 2,344.85	\$ 3,126.49	\$ 3,908.10	\$ 4,689.71
4 - 6 Yard	\$ 1,032.43	\$ 2,158.49	\$ 3,097.31	\$ 4,129.78	\$ 5,162.24	\$ 6,194.65
5 - 6 Yard	\$ 1,283.16	\$ 2,698.08	\$ 3,849.57	\$ 5,132.75	\$ 6,415.96	\$ 7,699.14

<b>AB939 Fee, per unit, per month, in additional to the above Trash or Split Bin Rates</b>	\$	0.30
<b>Multi-Family Organics Cart - STAB</b>		
1 - 96gal, 1x/wk	\$	18.87
2 - 96gal, 1x/wk	\$	37.70
3 - 96gal, 1x/wk	\$	56.57
4 - 96gal, 1x/wk	\$	75.45
5 - 96gal, 1x/wk	\$	94.29
<b>Multi-Family Organics Bin- STAB</b>		
2-Yard 1x/wk	\$	180.72
2 - Yard 2x/wk	\$	343.36

<b>Multi-Family Organics Cart - DISMOUNT</b>		
96gal, 1x/wk	\$	25.67
2 - 96gal, 1x/wk	\$	51.35
3 - 96gal, 1x/wk	\$	77.03
4 - 96gal, 1x/wk	\$	102.71
5 - 96gal, 1x/wk	\$	128.39
<b>Multi-Family Organics Bin - DISMOUNT</b>		
2-Yard 1x/wk	\$	226.44
2 - Yard 2x/wk	\$	429.20

<b>Multi-Family Organics Cart - STAGE</b>		
96gal, 1x/wk	\$	30.92
2 - 96gal, 1x/wk	\$	61.85
3 - 96gal, 1x/wk	\$	92.77
4 - 96gal, 1x/wk	\$	123.70
5 - 96gal, 1x/wk	\$	154.64
<b>Multi-Family Organics Bin - STAGE</b>		
2-Yard 1x/wk	\$	284.14
2 - Yard 2x/wk	\$	538.82

<b>Multi-Family Other Fees</b>	
1.5 Yard Extra PU	\$ 80.89
3 Yard Extra PU	\$ 105.27
6 Yard Split Bin Extra PU	\$ 166.32
Contamination	\$ 30.00
Reactivation/Cut-Off	\$ 52.42
Locking Lid	\$ 16.94
Overage	\$ 71.04

**CITY OF ARCADIA  
THIRD AMENDMENT TO  
RESIDENTIAL REFUSE AND RECYCLING AGREEMENT**

This Third Amendment to the Residential Refuse and Recycling Agreement (“Third Amendment”) is made and entered into on this, \_\_\_\_\_ day of \_\_\_\_\_, 2026 (the “Effective Date”) by and between the CITY OF ARCADIA, a Municipal Corporation, hereinafter referred to as “City”, and WASTE MANAGEMENT OF SAN GABRIEL/POMONA VALLEY, hereinafter referred to as “Contractor”.

**WHEREAS**, the City is responsible for providing solid waste handling services to its citizens, including source reduction, recycling activities and the collection, transfer, and disposal of solid waste within the City boundaries subject to solid waste handling jurisdiction, as provided in Section 40057 through 40059 of the Public Resources Code (Waste Management Act (the “Act”)); and

**WHEREAS**, the purposes of the Act are to promote the reduction, recycling, and reuse of solid waste to the maximum extent feasible in an efficient and cost-effective manner, to improve regulation of landfills, to streamline permitting procedures and to specify the role of local agencies to develop and implement integrated waste management programs, including setting the level of services, charges and the nature, location, and extent of the provision of solid waste handling services; and

**WHEREAS**, the collection of residential solid waste and recycling is crucial to the health, safety, and welfare of the City.

**WHEREAS**, City and Contractor entered into an agreement entitled Residential Refuse and Recycling Agreement dated March 10, 2009 (“Agreement”) for the collection of residential solid waste and recyclables in the City; and

**WHEREAS**, City and Contractor entered into an amendment of that Agreement entitled “First Amendment” to the Residential Refuse and Recycling Agreement dated October 16, 2013, whereby term of the Agreement, among other things, was extended through June 30, 2021; and

**WHEREAS**, City and Contractor entered into an amendment of that Agreement entitled “Second Amendment” to the Residential Refuse and Recycling Agreement dated July 1, 2021, whereby term of the Agreement, among other things, was extended through June 30, 2026; and

**WHEREAS**, City and Contractor are entered into an amendment of the Agreement entitled “Third Amendment” to the Residential Refuse and Recycling Agreement dated June 16, 2026, whereby the term of the Agreement, among other things, was extended through June 30, 2031; and

**WHEREAS** the service rates will continue to include an annual rate Adjustment Methodology Formula that includes two indices: a Disposal/Diversion Component and a Service Component; and

**WHEREAS** the Disposal/Diversion Component consists of costs for tipping fees charged at landfills for trash, tipping fees charged at composting facilities for green waste/food waste, and recycling fees at processing/recycling facilities; and

**WHEREAS** the Disposal/Diversion Component is given a 40% weight in the calculation of the new rate; and

**WHEREAS** the Service Component is based on monthly percent changes in the Consumer Price Index (“CPI”) for Los Angeles-Long Beach-Anaheim, between the current year and the prior year, and a 60% weight in the calculation of the new rate; and

**WHEREAS**, the proposed service rate adjustment includes an increase in labor fees totaling \$154,019.79, that would be phased in over two years for Fiscal Years (“FY”) 2026-27 and 2027-28 and would be divided evenly, with 50% in Single-Family rates and 50% in Multi-Family rates; and

**WHEREAS**, effective July 1, 2026, Single-Family rates will be raised by the annual rate adjustment + the \$0.28 labor fee for standard services; and

**WHEREAS**, effective July 1, 2026, Multi-Family rates will be raised by the annual rate adjustment + \$0.09 per yard per pickup labor fee for standard services; and

**WHEREAS**, effective July 1, 2026, the split bin rate will be raised by the annual rate adjustment + the \$0.58 labor fee for trash services; and

**WHEREAS**, in FY 2028-29 through FY 2030-31, there will be no labor fees, and the rate adjustment formula will go back to using the two indices included in the rate adjustment formula: 60% of the Consumer Price Index and 40% of the Disposal/Diversion rate adjustment factor; and

**WHEREAS**, contamination rates must follow the regional average and not the annual rate adjustment formula; and

**WHEREAS**, Contractor will add an additional Mulch Giveaway Event each fiscal year, changing Section B.2.c. of the Agreement to the following: Mulch. Contractor shall provide forty (40) cubic yards of mulch for three City-sponsored events per calendar year; and

**WHEREAS**, as permitted in Section DD of the Agreement, should the City and Contractor desire to extend the term and modify certain performance requirements of the Agreement further, a Fourth Amendment is required before June 30, 2031.

**IN WITNESS WHEREOF**, said City has caused its corporate name and seal to be hereunto subscribed and affixed by the Mayor and City Clerk, both thereunto duly authorized, and said Contractor has hereunto subscribed to his name.

**[SIGNATURES ON NEXT PAGE]**

CITY OF ARCADIA  
A Municipal Corporation

Waste Management, INC.

By: \_\_\_\_\_  
Dominic Lazzaretto  
City Manager

By: \_\_\_\_\_  
President's Signature  
Name \_\_\_\_\_

ATTEST:

\_\_\_\_\_  
City Clerk

By: \_\_\_\_\_  
Secretary Signature  
Name \_\_\_\_\_

APPROVED AS TO FORM:

\_\_\_\_\_  
Michael J. Maurer  
City Attorney

**Letter of Protest**

**Date:** May 04, 2026

**To:** Office of the City Clerk- Solid Waste Rate Adjustment Hearing

**Subject:** Letter of protest to proposed rate increase

RECEIVED  
CITY OF ARCADIA  
MAY 08 2026  
CITY MANAGER

Dear City Clerk,

- 1) I am opposed to the proposed rate adjustments for the refuse and recycling service charges.
- 2) My name is Ta Cheng Tung, and I am the authorized signatory.
- 3) Address: 217 West Naomi Ave. Arcadia, CA 91007  
Assessor's Parcel Number: 578500501325000
- 4) Printed Name: Ta Cheng Tung

Signature:



Sincerely,  
Ta Cheng Tung

**Letter of Protest**

RECEIVED  
CITY OF ARCADIA

MAY 08 2026

CITY MANAGER

**Date:** May 04, 2026

**To:** Office of the City Clerk- Solid Waste Rate Adjustment Hearing

**Subject:** Letter of protest to proposed rate increase

Dear City Clerk,

- 1) I am opposed to the proposed rate adjustments for the refuse and recycling service charges.
- 2) My name is Ta Cheng Tung, and I am the property owner.
- 3) Address: 423 West Naomi Ave. Arcadia, CA 91007  
Assessor's Parcel Number: 5784009013
- 4) Printed Name: Ta Cheng Tung

Signature:



Sincerely,

Ta Cheng Tung

**Letter of Protest**

RECEIVED  
CITY OF ARCADIA

MAY 08 2026

CITY MANAGER

**Date:** May 04, 2026

**To:** Office of the City Clerk- Solid Waste Rate Adjustment Hearing

**Subject:** Letter of protest to proposed rate increase

Dear City Clerk,

- 1) I am opposed to the proposed rate adjustments for the refuse and recycling service charges.
- 2) My name is Ta Cheng Tung, and I am the authorized signatory.
- 3) Address: 63 West Naomi Ave. Arcadia, CA 91007  
Assessor's Parcel Number: 5782010023
- 4) Printed Name: Ta Cheng Tung

Signature:



Sincerely,

Ta Cheng Tung

# SVEN DAVIDSON

■ 832 Monte Verde Drive  
■ Arcadia, California  
91007  
■ Assessor's ID.NO.:  
5776 013 016 21 000

May 8, 2026

RECEIVED

MAY 14 2026

**Office of the City Clerk – Rate Hearing**  
City of Arcadia  
240 West Huntington Drive  
Arcadia, California 91007

CITY OF ARCADIA  
CITY CLERK

Gentlemen,

I am the owner of 832 Monte Verde Drive in Arcadia.

I am writing this letter to protest the proposed increase to the Water and Sewer Service Charges rates.

Sincerely,



Sven Davidson

Record Owner

## **Public Hearing Item 10.e.**

Resolution No. 7702 adopting the City of Arcadia  
2025 Urban Water Management Plan and Water  
Shortage Contingency Plan

**ARCADIA CITY COUNCIL  
SPECIAL MEETING MINUTES  
TUESDAY, JUNE 2, 2026**

---

---

**CALL TO ORDER** – Mayor Cheng called the Special Meeting to order at 5:00 p.m.

**ROLL CALL OF CITY COUNCIL MEMBERS**

PRESENT: Cao, Kwan, Fu, and Cheng

ABSENT: None

City Manager Lazzaretto announced that the following five applicants had withdrawn their applications for appointment to the District 3 vacancy:

Ruby Chang  
Gail Littlejohn  
Eduardo Magallanes  
William Wu  
Peter Yoo

Mayor Cheng outlined the meeting procedures and interview process for the District 3 City Council vacancy appointment; he explained the format of candidate interviews, and the process for deliberation and selection following the interviews.

**PUBLIC COMMENT**

April Verlato, former Arcadia Mayor and resident, appeared and urged the City Council not to make an appointment to fill the District 3 vacancy, stating that District 3 voters should select their representative through the election process in November.

Judy Hermann, an Arcadia resident, appeared and expressed concerns regarding the appointment process; she inquired about residency requirements for City Council candidates; and she stated that a three-month residency seemed insufficient to qualify for office.

City Attorney Maurer explained the residency requirements for City Council candidates, including appointments, pursuant to the City Charter.

Beth Costanza, former Executive Director of the Arcadia Chamber of Commerce, appeared and encouraged the City Council to take sufficient time to thoroughly vet applicants, emphasizing the importance of selecting a candidate who is knowledgeable about the City's history and community.

MJ, an Arcadia resident, appeared and discussed responses she received to a social media post regarding interview questions for District 3 applicants; she also expressed concerns regarding the “No Turn on Red” traffic signals on Baldwin Avenue, stating that the signage has caused confusion for drivers.

In response to Mayor Cheng’s inquiry, MJ further described the confusion created by the “No Turn on Red” traffic signals.

In response to Mayor Pro Tem Fu’s inquiry, City Manager Lazzaretto stated that the City Engineer is evaluating the issue and working to balance pedestrian safety and driver concerns.

### **OPEN SESSION TO THE PUBLIC**

- a. Interview candidates for appointment to fill the unexpired term of City Council Member representing District 3.  
CEQA: Not a Project  
Recommended Action: Conduct Interviews and Make Appointment

Mayor Cheng announced that the candidates would have a few minutes to provide opening remarks and that each Council Member would ask them two questions each, with each interview lasting approximately 12 minutes.

The City Council interviewed the following six (6) potential candidates for appointment:

Walter Besocke  
John Han  
Cynthia Ng Monje  
Beth Szymkowski  
Paul Van Fleet  
Lisa Walton

At the conclusion of the interviews and City Council discussion, Mayor Cheng continued the Special Meeting until the Regular Meeting.

The City Council recessed at 6:58 p.m. and reconvened at 10:11 p.m.

Following additional discussion, it was the consensus of the City Council to table this item to the June 16, 2026, City Council meeting at 6:00 p.m. in the City Council Chambers, and to once again televise the meeting.

The Special Meeting ended at meeting 10:19 p.m.

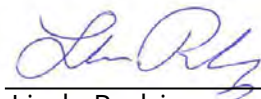

---

Linda Rodriguez  
City Clerk

**ARCADIA CITY COUNCIL  
REGULAR MEETING MINUTES  
TUESDAY, JUNE 2, 2026**

---

1. **CALL TO ORDER** – Mayor Pro Tem Cheng called the Regular Meeting to order at 7:01 p.m.
2. **INVOCATION** – Terrence Shay, Arcadia Police Department Chaplain
3. **PLEDGE OF ALLEGIANCE** – Terrence Shay, Arcadia Police Department Chaplain
4. **ROLL CALL OF CITY COUNCIL MEMBERS**

PRESENT: Cao, Kwan, Fu and Cheng  
ABSENT: None

5. **REPORT FROM CITY ATTORNEY REGARDING CLOSED/STUDY SESSION ITEMS**

City Attorney Maurer reported that a Closed Session item was scheduled for later in the meeting; he stated that prior to the Regular Meeting, the City Council met in a Special Meeting to conduct interviews for the District 3 City Council vacancy; and he indicated that the Special Meeting had been continued until after the Regular Meeting.

6. **SUPPLEMENTAL INFORMATION FROM CITY MANAGER REGARDING AGENDA ITEMS**

City Manager Lazzaretto stated that, since the Special Meeting to address the District 3 City Council vacancy had been continued to later in the Regular Meeting, City Clerk Item 7.a. – Administration of the oath of office to District 3 Council Member, would not be considered at this time.

7. **CITY CLERK**

- a. Administration of the oath of office to District 3 Council Member.

Mayor Cheng tabled this item.

8. **PRESENTATIONS**

- a. Presentations of Mayor's Certificates of Commendation to the Junior Team Tennis USTA Southern California BBQ Ninjas Team for placing 1<sup>st</sup> in the San Gabriel Valley region and placing 2<sup>nd</sup> throughout the Southern California Division.

- b. Presentation of Mayor's Certificates of Commendation to the Arcadia High School Color Guard for winning the National Championship Title.
- c. Presentation of the 2026 Spring Home Awards.
- d. Presentation of America's 250<sup>th</sup> Anniversary Proclamation to Lieutenant Colonel Victor Shen of the United States Army.

**9. PUBLIC HEARING**

- a. Resolutions relating to the adoption of the Fiscal Year 2026-27 Operating Budget and the Fiscal Years 2026-27 through 2030-31 Capital Improvement and Equipment Plan.

Resolution No. 7696 adopting a Budget for Fiscal Year 2026-27 and appropriating the amounts specified therein as expenditures from the various funds.

CEQA: Not a Project

Recommended Action: Adopt

Resolution No. 7697 adopting a Capital Improvement and Equipment Plan for Fiscal Years 2026-27 through 2030-31.

CEQA: Not a Project

Recommended Action: Adopt

Mayor Cheng opened the public hearing.

Dom Tallerico, an Arcadia resident, appeared and encouraged the City Council to conduct a forensic accounting audit of the City's financial records, stating that such an audit would help corroborate the City's position that there was no inappropriate behavior by former Mayor Eileen Wang.

Mayor Cheng closed the public hearing.

A motion was made by Mayor Cheng, seconded by Council Member Cao, and carried on a roll call vote to table this item to the June 16, 2026, City Council meeting.

AYES: Cheng, Cao, Kwan, and Fu

NOES: None

ABSENT: None

## 10. PUBLIC COMMENTS

Sean Lee, appeared and stated that recent controversy involving the City Council and media coverage has negatively affected his business; he expressed a desire to become more involved in the community and offered a discount to Arcadia residents who visit his auto body shop.

Jennifer Lu, an Arcadia resident, appeared and discussed an ongoing code enforcement matter related to the height of hedges on her property; and she expressed privacy concerns regarding the reduction of the hedges.

Steve Rhee, an Arcadia resident, appeared and expressed frustration regarding the City Council's decision not to select a candidate to fill the District 3 vacancy during the earlier Special Meeting.

Scott Daves, an Arcadia resident, appeared and expressed concerns regarding matters involving former Mayor Eileen Wang; he also shared concerns related to former District 3 applicant William Wu; and he encouraged the City Council to carefully evaluate candidates moving forward.

Dom Tallerico, an Arcadia resident, appeared and provided information regarding forensic audits; and he encouraged the City Council to conduct a forensic accounting audit of the City's financial records, stating that such an audit could help address public concerns regarding matters involving former Mayor Eileen Wang.

Ophelia Chan, an Arcadia resident, appeared and expressed disappointment with the City Council's handling of matters related to former Mayor Eileen Wang, and the lack of public discussion surrounding those matters, including comments made by former Mayor Tom Beck; she also recommended the installation of a baby changing station in the City Council Chambers restroom.

Diego, an Arcadia resident, appeared and thanked the City Council and staff for their efforts related to filling the District 3 vacancy; he expressed appreciation that the interviews were conducted in an open public meeting; and encouraged the City Council to make an appointment.

Deron Street, appeared and expressed concern regarding negative publicity involving the City and the direction of the community; and he encouraged the City Council to focus on community issues, work collaboratively, and provide transparent and unified leadership.

Mike Durgerian, an Arcadia resident, appeared and paid tribute to the Street family for their contributions to the community; he expressed concerns regarding recent City matters; he

emphasized the importance of fiscal responsibility and transparency; and he encouraged the City Council to focus on issues affecting the residents.

Burton Brink, an Arcadia resident, appeared and referenced comments he made at the May 19, 2026, City Council meeting regarding accountability and transparency matters involving former Mayor Eileen Wang; he stated that characterizations of his comments as racist were false and offensive; he emphasized that his concerns were related to leadership, ethics, and transparency; he encouraged the City Council to uphold integrity and transparency; and he stated that future Council Members should be selected based on character, community involvement, and dedication to the City.

Jonathan Rodriguez and James Alewine, Board Members of the Arcadia Chamber of Commerce, appeared and thanked the City Council for their continued support; and they provided an update on the following networking events: Lunch Link at Don Ricardo's on June 9 and Taste of Arcadia at Santa Anita Park on September 19.

Angela Hui, an Arcadia resident, appeared and expressed concerns regarding public safety issues associated with e-bikes and their impact on pedestrians; she encouraged the City and the Arcadia Unified School District to provide parents with information regarding local e-bike regulations and legal responsibilities.

Eli Tsou, an Arcadia resident, appeared and expressed concerns regarding the City's leadership and the City Council's response to concerns raised by the public at the prior meeting; and he emphasized the importance of selecting a District 3 representative who would effectively represent the interests of the community.

Mayor Pro Tem Fu requested to speak on a matter of personal privilege.

In response to Mayor Cheng's request for clarification on points of personal privilege, City Attorney Maurer explained that pursuant to the Brown Act and the City's policy, City Council Members may briefly respond to statements made during public comment that personally affect them.

Mayor Pro Tem Fu responded to an earlier public comment that referenced former Mayor Tom Beck.

Mayor Cheng warned members of the public that continued disruptions would not be permitted and could result in their removal from the meeting.

Council Member Kwan addressed a matter of personal privilege concerning an email received by the City Council earlier that day regarding a private event she attended in 2017.

The City Council recessed at 8:41p.m. and reconvened at 8:52 p.m.

Council Member Kwan completed her comments regarding an email received by the City Council earlier that day regarding a private event she attended in 2017.

## 11. CONSENT CALENDAR

- a. Regular Meeting Minutes of May 19, 2026.

CEQA: Not a Project

Recommended Action: Approve

- b. Resolutions relating to the General Municipal Election to be held on Tuesday, November 3, 2026.

Resolution No. 7686 calling for a General Municipal Election to be held on Tuesday, November 3, 2026, for the election of members of the City Council in Electoral Districts 2, 3, and 5, as required by the laws governing charter cities.

CEQA: Not a Project

Recommended Action: Adopt

Resolution No. 7687 requesting the Board of Supervisors of the County of Los Angeles to consolidate a General Municipal Election to be held on Tuesday, November 3, 2026, with the Statewide General Election to be held on the same date pursuant to Section 10403 of the California Elections Code.

CEQA: Not a Project

Recommended Action: Adopt

Resolution No. 7688 adopting regulations for candidates for elective office pertaining to candidate statements submitted to the voters at a General Municipal Election to be held on Tuesday, November 3, 2026.

CEQA: Not a Project

Recommended Action: Adopt

- c. Resolution No. 7689 adopting a list of projects for Fiscal Year 2026-27 funded by SB 1: The Road Repair and Accountability Act of 2017.

CEQA: Not a Project

Recommended Action: Adopt

- d. Resolutions initiating proceedings for the annual levy and collection of assessments, approving the Preliminary Engineer's Report, declaring intention to levy and collect assessments for Fiscal Year 2026-27, and appointing a time and place for a public hearing for the Arcadia Citywide Lighting District No. 1.

Resolution No. 7690 initiating proceedings for the annual levy and collection of assessments for the Arcadia Citywide Lighting District No. 1, pursuant to the

provisions of Part 2 of Division 15 of the California Streets and Highways Code and ordering the preparation of the Engineer's Report.

CEQA: Not a Project

Recommended Action: Adopt

Resolution No. 7691 approving the preliminary Engineer's Report of Willdan Financial Services for the Arcadia Citywide Lighting District No. 1.

CEQA: Not a Project

Recommended Action: Adopt

Resolution No. 7692 declaring its intention to levy and collect assessments within the Arcadia Citywide Lighting District No. 1 for Fiscal Year 2026-27 and appointing a time and place for a public hearing.

CEQA: Not a Project

Recommended Action: Adopt

- e. Resolution No. 7695 establishing an appropriation limit for Fiscal Year 2026-27 pursuant to Article XIII-B of the California Constitution.

CEQA: Not a Project

Recommended Action: Adopt

- f. Mayor's appointments of City Council Members to City Boards and Commissions, and outside agencies.

CEQA: Not a Project

Recommended Action: Receive and File

- g. Statement of Investment Policy for Fiscal Year 2026-27.

CEQA: Not a Project

Recommended Action: Approve

- h. Professional Services Agreement with Liebert Cassidy Whitmore in an amount not to exceed \$75,000 in Fiscal Year 2026-27 to finalize currently in-process legal services; and Professional Services Agreement with Atkinson, Andelson, Loya, Ruud & Romo for professional legal services in the full scope of specialized labor and employment matters, in an amount not to exceed \$285,000, over a two-year period.

CEQA: Not a Project

Recommended Action: Approve

- i. Change Order to increase the Purchase Order with Performance Truck Repair Inc. for fire apparatus service and repairs in the amount of \$50,000.

CEQA: Not a Project

Recommended Action: Approve

- j. Accept all work performed by Horizons Construction Co. Int'l Inc. for the Debris Basins Debris Removal Project as complete.

CEQA: Exempt

Recommended Action: Approve

Council Member Kwan pull Consent Calendar Item 11.h. for separate discussion.

Council Member Kwan expressed concern regarding the proposed expenditure for outside legal services; she questioned why the item was included on the Consent Calendar; and she emphasized the importance of transparency regarding the City's legal expenditures.

City Manager Lazzaretto explained that the agreement pertained to labor and employment legal services for the City's day-to-day operations as well as labor negotiations; he noted that the City was transitioning from Liebert Cassidy Whitmore to Atkinson, Andelson, Loya, Ruud & Romo ("AALRR") due to service needs and clarified that the agreement was not related to litigation matters. He further explained that, while the City has experienced an increase in litigation and legal expenses in recent years, those costs are accounted for separately.

In response to Council Member Kwan's inquiries, Human Resources Director Williams stated that the agreement was intended to support routine labor and employment legal services, including labor negotiations; she clarified that it was not related to specific lawsuits; she noted that expenditures for such services average approximately \$75,000 annually, excluding labor negotiation years; and she indicated that information regarding outside legal service costs from prior years would be provided.

In response to Council Member Cao's inquiries, City Manager Lazzaretto noted legal costs associated with public records requests are not related to this agreement, and explained the reasons items are placed on the Consent Calendar.

Mayor Cheng reminded the City Council that additional information and supporting documents may be requested from staff prior to the Council Meeting and noted that litigation matters are discussed in Closed Session as required by law; he acknowledged the increase in legal expenditures and encouraged respectful discussion among Council Members.

Mayor Pro Tem Fu clarified that the agreement established an amount for future legal services and did not represent funds already expended.

City Manager Lazzaretto noted that any member of the public or City Council may request that a Consent Calendar item be pulled for separate discussion.

Mayor Cheng reminded the City Council should remain focused on matters relevant to agenda items under consideration.

It was moved by Council Member Cao, seconded by Mayor Pro Tem Fu, and carried on a roll call vote to approve Consent Calendar Items 11.a through 11.j.

AYES: Cao, Fu, Kwan, and Cheng  
NOES: None  
ABSENT: None

## **12. CITY MANAGER**

- a. Resolution No. 7694 adopting the Telephonic and Internet Service Disruption Policy for City Council Meetings.

CEQA: Not a Project

Recommended Action: Adopt

Deputy City Manager Bruno presented the Staff Report.

After discussion, it was moved by Mayor Pro Tem Fu, seconded by Council Member Cao, to adopt Resolution No. 7694 adopting the Telephonic and Internet Service Disruption Policy for City Council Meetings.

Council Member Kwan made a substitute motion to amend the policy to require that a meeting be adjourned and continued to a future date in the event of a power outage. The motion failed for lack of a second.

Mayor Cheng requested a roll call vote on the original motion made by Mayor Pro Tem Fu, which carried as follows:

AYES: Fu, Cao, and Cheng  
NOES: Kwan  
ABSENT: None

## **13. AB 1234 REPORTS FROM MAYOR AND CITY COUNCIL (*limited to legally required reports*).**

No Council Members had anything to report.

## **14. REQUEST FOR FUTURE ITEMS**

Council Member Kwan requested City Council support to place an item on a future agenda to discuss conducting a forensic accounting audit of the City's financial records related to former Council Member Eileen Wang. No support was expressed for this request.

Mayor Cheng requested City Council support to place an item on a future agenda to discuss the City's interactions with foreign governments and the role of the City Council in such matters. Mayor Pro Tem Fu and Council Member Kwan concurred.

Prior to Closed Session, Mayor Cheng provided remarks in honor of Ron Street and invited his family members in the audience to share any remarks.

The City Council recessed from the Regular Meeting and reconvened to the earlier Special Meeting, at 10:11p.m.

Upon conclusion of the Special Meeting, the City Council reconvened to Closed Session at 10:19 p.m.

**15. CLOSED SESSION**

- a. Pursuant to Government Code Section 54956.9 (d)(1) to confer with legal counsel regarding the matter of David Liu, et al v City of Arcadia, et all; and Does 1-100, inclusive (Case No. 26STCV13804).

Following Closed Session, City Attorney Maurer reported that, on a 4-0 vote, the City Council directed legal counsel to defend the lawsuit.

**16. ADJOURNMENT**

The City Council adjourned in memory of Ron Street, long-time Arcadia resident, at 10:48 p.m. to Tuesday, June 16, 2026, at 6:00 p.m., in the City Council Chambers.

  
\_\_\_\_\_  
Linda Rodriguez  
City Clerk

**DATE:** June 16, 2026

**TO:** Honorable Mayor and City Council

**FROM:** Roy Nakamura, Chief of Police  
By: Amber Abeyta, Management Analyst

**SUBJECT:** RESOLUTION NO. 7701 AUTHORIZING A SUPPLEMENTAL BUDGET APPROPRIATION IN THE AMOUNT OF \$35,707, FROM THE GENERAL FUND RESERVE; AND APPROVING THE SUPPORT AGREEMENT RENEWAL FOR THE POWER911/VIPER SYSTEM AND PURCHASE ORDER FOR RELATED EQUIPMENT WITH AT&T, IN AN AMOUNT NOT TO EXCEED \$35,707

**CEQA: Not a Project**

**Recommendation: Adopt and Approve**

### **SUMMARY**

The City utilizes the Power911/VIPER (Voice over IP Emergency Response) system for managing 911 calls and associated equipment. This system ensures that emergency calls are handled swiftly and efficiently, allowing dispatchers to quickly connect callers with the necessary services. AT&T is the current equipment and maintenance provider of the Power911/VIPER system. AT&T recently notified the City that the Support Agreement for maintenance is due for renewal, costing \$19,072.72. Additionally, the uninterruptible power supply ("UPS") system, which serves as a backup battery for the 911 system, needs replacement at \$15,054. The total cost is approximately \$35,707.

Since notification of the Support Agreement renewal and the need to replace the UPS system were received after budget development, funds were not allocated for this expense in the Fiscal Year 2025-26 General Fund Operating Budget. Consequently, an appropriation from the General Fund Reserve is necessary to cover the unplanned expense. It should be noted that the California Governor's Office of Emergency Services ("Cal OES") serves as the lead administrator and funding source of the

statewide 911 emergency communications system and will reimburse the City for the total cost of the Support Agreement renewal and UPS system replacement.

It is recommended that the City Council adopt Resolution No. 7701 authorizing a supplemental budget appropriation in the amount of \$35,707, from the General Fund Reserve; and approve the Support Agreement renewal for the Power911/VIPER System and Purchase Order for related equipment with AT&T, in an amount not to exceed \$35,707.

### **BACKGROUND**

In 2017, Cal OES entered an Agreement (Attachment No. 1) with AT&T to replace and upgrade the existing 911 system known as "Intrado," with a new system called "Power911/VIPER (Voice over IP Emergency Response)." The replacement and upgrade delivered new hardware, software, and associated equipment to ensure that the system remains efficient in its operation. The Agreement included provisions for the ongoing maintenance of the new system. As a result, the Agreement was expanded to include California agencies such as Arcadia (Attachment No. 2), which utilize the 911 system and were mandated to implement the Power911/VIPER system. The City implemented the new 911 system and currently receives ongoing maintenance support from AT&T. The expenses related to the system upgrade and maintenance were covered by Cal OES.

### **DISCUSSION**

AT&T recently informed the City that the Support Agreement for maintenance expired in December 2025 and is due for renewal. The delayed notification is a result of recent staffing changes. The renewal period will be for a one-year term covering the period of December 7, 2025, to December 6, 2026. Despite the Support Agreement having expired in December 2025, AT&T has continued to provide uninterrupted maintenance service.

Furthermore, the Uninterruptible Power Supply ("UPS") system, which serves as a backup battery in the event of a power outage for the 911 system and other critical equipment, must be replaced. The replacement of the UPS has become necessary due to the age of the system. In addition, AT&T can no longer maintain the existing system, and replacement is required to ensure continued service support.

The cost of the Support Agreement is \$19,072.72, while the UPS system replacement amounts to \$15,054, bringing the total cost to \$35,707, including tax. Cal OES will reimburse the City for the cost of the Support Agreement and replacement of the UPS system.

### **ENVIRONMENTAL ANALYSIS**

The proposed action does not constitute a project under the California Environmental Quality Act ("CEQA"), based on Section 15061(b)(3) of the CEQA Guidelines, as it can be seen with certainty that it will have no impact on the environment.

### **FISCAL IMPACT**

Since this purchase was not included in the Fiscal Year 2025-26 General Fund Operating Budget, a supplemental budget appropriation is requested to cover the total expense of approximately \$35,707. The City will be fully reimbursed for this cost by Cal OES.

### **RECOMMENDATION**

It is recommended that the City Council determine that this action does not constitute a project under the California Environmental Quality Act ("CEQA"); and adopt Resolution No. 7701 authorizing a supplemental budget appropriation in the amount of \$35,707, from the General Fund Reserve; and approving the Support Agreement renewal for the Power911/VIPER System and Purchase Order for related equipment with AT&T, in an amount not to exceed \$35,707.

Approved:



Dominic Lazzaretto  
City Manager

Attachment No. 1: Cal OES and AT&T Agreement

Attachment No. 2: Power911/VIPER System Acceptance and Scope of Work

Attachment No. 3: Support Agreement Quote

Attachment No. 4: Resolution No. 7701

**Attachment No. 1**

STATE OF CALIFORNIA  
**STANDARD AGREEMENT**  
 STD. 213 (REVISED 07/13)

PURCHASING AUTHORITY NUMBER	REGISTRATION NUMBER
	AGREEMENT NUMBER <b>4145-6</b>



- This Agreement is entered into between the State Agency and the Contractor named below  
**STATE AGENCY'S NAME**  
 California Governor's Office of Emergency Services  
**CONTRACTOR'S NAME**  
 Pacific Bell Telephone Company dba AT&T California, AT&T Wholesale, AT&T DataComm
- The term of this Agreement is: April 10, 2017, or upon California Department of Technology approval, whichever is the later, through April 9, 2020
- The maximum amount of this Agreement is:** \$0.00  
Zero Dollars and Zero Cents
- The parties agree to comply with the terms and conditions of the following attachments which are by this reference made a part of the Agreement:

Appendix A – Statement of Work	49 pages
Attachment 1.0 – Contractor's Monthly Activity Report	1 page
Attachment 2.0 – Contractor's Monthly Service Level Agreement Compliance Report Turn-Key 9-1-1 CPE System	1 page
Attachment 2.1 – Contractor's Monthly Service Level Agreement Compliance Report 9-1-1 CPE Host-Remote System	1 page
Attachment 3.0 – Contractor's Sample Statement of Work Turn-Key 9-1-1 CPE System Format	3 pages
Attachment 3.1 – Contractor's Sample Statement of Work 9-1-1 CPE Host-Remote System Format	3 pages
Attachment 4.0 – Turn-Key 9-1-1 CPE System Acceptance and Authorization Checklist	5 pages
Attachment 4.1 – 9-1-1 CPE Host-Remote System Acceptance and Authorization Checklist	5 pages
Attachment 5.0 – Required Call Detail Record (CDR) Elements	14 pages
Attachment 6.0 – Call Data Record Format	10 pages
Appendix B – Budget Detail, Invoicing and Payment Provisions	2 pages
Exhibit 16 – Cost Workbook	12 pages
(*) IFB 8500-2016 in its entirety	140 pages
(*) Contractor's Final Response to IFB 8500-2016 in its entirety	222 pages
(*) Appendix C – General Provisions – Information Technology (GSPD – 401IT-09/05/2014)	12 pages

**FULLY EXECUTED**

*Items shown with an Asterisk (\*), are hereby incorporated by reference and made part of this agreement as if attached hereto.*

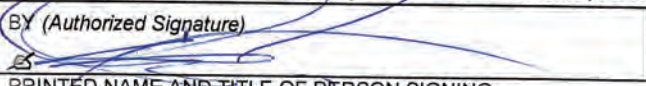
**IN WITNESS WHEREOF, this Agreement has been executed by the parties hereto.**

CONTRACTOR		Statewide Technology Procurement Division Use Only	
CONTRACTOR'S NAME (If other than an individual, state whether a corporation, partnership, etc.) Pacific Bell Telephone Company dba AT&T California, AT&T Wholesale, AT&T DataComm		<div style="font-size: 2em; color: blue; text-align: center;">                     Approved                      By JFors                      6 JUN 2017                 </div>	
BY (Authorized Signature) 	DATE SIGNED 5.18.17		
PRINTED NAME AND TITLE OF PERSON SIGNING Christopher Roy, VP Business Solutions – Global Business			
ADDRESS 208 S. Akard Street, Room 830 Dallas, TX 75202			
STATE OF CALIFORNIA			
AGENCY NAME California Governor's Office of Emergency Services		<input type="checkbox"/> Exempt per	
BY (Authorized Signature) 	DATE SIGNED 06/01/17		
PRINTED NAME AND TITLE OF PERSON SIGNING Sara Stillwell, Assistant Director, Administrative Services Section			
ADDRESS 3650 Schriever Avenue Mather, CA 95655			

---

**APPENDIX A  
STATEMENT OF WORK**

---

**9-1-1 CPE SYSTEMS  
STATEMENT OF WORK (SOW)**

**1.1. BACKGROUND AND PURPOSE**

The California Governor's Office of Emergency Services (Cal OES), CA 9-1-1 Emergency Communications Branch (CA 9-1-1 Branch) is responsible for administering the State Emergency Telephone Number Account (SETNA) which provides funding to California Public Safety Answering Points (PSAPs) for 9-1-1 systems and services. User Instructions will be provided to PSAPs upon Contract Award for detailing the process to follow when ordering 9-1-1 Customer Premise Equipment (CPE) Systems. The main function of the 9-1-1 CPE Systems are to provide PSAPs with call handling equipment located at the PSAP to answer the 9-1-1 calls.

**1.2. OBJECTIVE**

Cal OES, CA 9-1-1 Branch will oversee and approve all purchases made under this agreement. The PSAPs will use this agreement to purchase 9-1-1 CPE Systems with SETNA funding as authorized and approved by the CA 9-1-1 Branch.

**1.3. PSAP LOCATIONS**

PSAPs may be added or removed from time to time by the Cal OES for a variety of reasons. Not all PSAPs request or receive funding from the CA 9-1-1 Branch; therefore, the PSAPs List is not inclusive of all PSAPs in California. Some NG 9-1-1 Core Services exist today, or are planned and are designated by "CE" or "CP". Some PSAPs contain Evergreen Network based Turn-key Solutions that are existing or planned, designated by "EE" or "EP". The remaining PSAPs are all Stand-Alone CPE as "Blank" in the status field or Host-Remote Solutions designated with an "HS" as defined below:

Blank – CPE Stand-Alone

HS – CPE Host-Remote System

HS – B (Butte)

HS – I (Imperial)

HS – LAS (Los Angeles Sheriff)

HS – P (Placerville)

HS – R (Riverside)

HS – SC (Santa Clara)

HS – V (Ventura)

CE – Core Existing

CP – Core Planned

EE – Evergreen Existing

EP – Evergreen Planned

**Table 1.1 PSAPs CURRENTLY FUNDED BY SETNA**

#	PSAP NAME	STATUS	LOCATION
1)	Alameda County Regional Fire/LLNL		Livermore
2)	Alameda County Sheriff's Department		San Leandro
3)	Alameda Police Department		Alameda
4)	Albany Police Department		Albany
5)	Alhambra Police/Fire Department	EP, CP	Alhambra
6)	Amador County Sheriff's Department		Jackson
7)	Anaheim Police Department		Anaheim
8)	Antioch Police Department		Antioch
9)	Arcadia Police Department	EP, CP	Arcadia
10)	Arcata Police Department		Arcata
11)	Arvin Police Department		Arvin
12)	Atascadero Police Department		Atascadero
13)	Atherton Police Department		Atherton
14)	Atwater Police Department		Atwater
15)	Auburn Police Department	HS-P	Auburn
16)	Avalon Fire Department		Avalon
17)	Azusa Police Department		Azusa
18)	Bakersfield Police Department		Bakersfield
19)	Baldwin Park Police Department		Baldwin Park
20)	Banning Police Department		Banning
21)	Barstow Police Department		Barstow
22)	Bay Area Rapid Transit (BART) Police		Oakland
23)	Bear Valley Police Department		Tehachapi
24)	Beaumont Police Department		Beaumont
25)	Bell Gardens Police Department		Bell Gardens
26)	Bell Police Department		Bell
27)	Belmont Police Department		Belmont
28)	Benicia Police Department		Benicia
29)	Berkeley Police/Fire Communications Center		Berkeley
30)	Beverly Hills Police Department	EP, CP	Beverly Hills
31)	Bishop Police Department		Bishop
32)	Blythe Police Department		Blythe
33)	Brawley Police Department	HS-I	Brawley
34)	Brea Police Department		Brea
35)	Buena Park Police Department		Buena Park
36)	Burbank Police Department	EE, CP	Burbank
37)	Burlingame Police Department		Burlingame
38)	Butte County Sheriff's Department	CE, HS-	Oroville
39)	Calaveras County Sheriff's Department		San Andreas
40)	Calexico Police Department	HS-I	Calexico
41)	CAL-FIRE Camino (Amador/El Dorado Unit)		Camino
42)	CAL-FIRE El Cajon (San Diego Unit)		El Cajon
43)	CAL-FIRE Felton (San Mateo/Santa Cruz Unit)		Felton
44)	CAL-FIRE Fortuna (Humboldt/Del Norte Unit)		Fortuna

#	PSAP NAME	STATUS	LOCATION
45)	CAL-FIRE Fresno (Fresno/Kings Unit)		Fresno
46)	CAL-FIRE Grass Valley (Nevada/Yuba/Placer		Grass Valley
47)	CAL-FIRE Mariposa		Mariposa
48)	CAL-FIRE Monterey (San Benito/Monterey		Monterey
49)	CAL-FIRE Morgan Hill (Santa Clara Unit)		Morgan Hill
50)	CAL-FIRE Oroville (Butte Unit)	CE, HS-	Oroville
51)	CAL-FIRE Perris (Riverside Unit)		Perris
52)	CAL-FIRE Red Bluff (Tehama/Glenn Unit)	CE	Red Bluff
53)	CAL-FIRE Redding (Shasta/Trinity Unit)	CE	Redding
54)	CAL-FIRE San Andreas (Tuolumne/Calaveras		San Andreas
55)	CAL-FIRE San Bernardino (San Bernardino		San Bernardino
56)	CAL-FIRE San Luis Obispo (San Luis Obispo		San Luis Obispo
57)	CAL-FIRE St Helena (Sonoma/Lake/Napa		St Helena
58)	CAL-FIRE Susanville (Lassen/Modoc Unit)	CE	Susanville
59)	CAL-FIRE Visalia (Tulare Unit)		Visalia
60)	CAL-FIRE Willits (Mendocino Unit)		Willits
61)	CAL-FIRE Yreka (Siskiyou Unit)	CE	Yreka
62)	California City Police Department		California City
63)	Calistoga Police Department		Calistoga
64)	Campbell Police Department		Campbell
65)	Carlsbad Police Department		Carlsbad
66)	Carmel Police Department		Carmel
67)	Cathedral City Police Department		Cathedral City
68)	Ceres Police Department		Ceres
69)	Cerritos College Police Department		Norwalk
70)	Chico Police Department	CE	Chico
71)	Chino Police Department	HS-B	Chino
72)	Chowchilla Police Department		Chowchilla
73)	CHP Atwater (Merced)		Atwater
74)	CHP Bakersfield (Kern)		Bakersfield
75)	CHP Barstow (San Bernardino)		Barstow
76)	CHP Bishop (Inyo)		Bishop
77)	CHP Border Comm Center		San Diego
78)	CHP Capitol Communications Center		Sacramento
79)	CHP Chico (Butte)	CE	Chico
80)	CHP El Centro (Imperial)		Imperial
81)	CHP Eureka (Humboldt)		Arcata
82)	CHP Fresno		Fresno
83)	CHP Indio (Riverside)		Indio
84)	CHP Inland (San Bernardino)		Fontana
85)	CHP Irvine (Orange)		Irvine
86)	CHP Los Angeles		Los Angeles
87)	CHP Rancho Cordova (Sacramento)		Rancho Cordova
88)	CHP Redding (Shasta)	CE	Redding
89)	CHP Salinas (Monterey)		Salinas
90)	CHP San Luis Obispo		San Luis Obispo

#	PSAP NAME	STATUS	LOCATION
91)	CHP Stockton (San Joaquin)		Stockton
92)	CHP Susanville (Lassen)	CE	Susanville
93)	CHP Truckee (Nevada)		Truckee
94)	CHP Ukiah (Mendocino)		Ukiah
95)	CHP Vallejo/Golden Gate (Solano)		Vallejo
96)	CHP Ventura		Ventura
97)	CHP Yreka (Siskiyou)	CE	Yreka
98)	Chula Vista Police Department		Chula Vista
99)	Citrus Heights Police Department		Citrus Heights
100)	Claremont Police Department		Claremont
101)	Cloverdale Police Department		Cloverdale
102)	Clovis Police Department		Clovis
103)	Coalinga Police Department		Coalinga
104)	Colma Police Department		Colma
105)	Colton Police Department		Colton
106)	Colusa County Sheriff's Department	CE	Colusa
107)	Concord Police Department		Concord
108)	CONFIRE - San Bernardino County Fire		Rialto
109)	Contra Costa County Fire Protection District		Pleasant Hill
110)	Contra Costa County Sheriff's Department		Martinez
111)	Corcoran Police Department		Corcoran
112)	Corning Fire Department	CE	Corning
113)	Corning Police Department	CE	Corning
114)	Corona Police Department		Corona
115)	Coronado Police Department		Coronado
116)	Costa Mesa Police Department		Costa Mesa
117)	Cotati Police Department		Cotati
118)	Covina Police Department	EP,CP	Covina
119)	CSU Channel Island Police Department		Camarillo
120)	CSU Chico Police Department	CE, HS-	Chico
121)	CSU Dominguez Hills Police Department		Carson
122)	CSU East Bay Police Department		Hayward
123)	CSU Fresno Police Department		Fresno
124)	CSU Fullerton Police Department		Fullerton
125)	CSU Humboldt Police Department		Arcata
126)	CSU Long Beach University Police		Long Beach
127)	CSU Los Angeles Police Department		Los Angeles
128)	CSU Northridge University Police		Northridge
129)	CSU Pomona (Cal Poly) Police Department		Pomona
130)	CSU San Bernardino Police Department		San Bernardino
131)	CSU San Diego Police Department		San Diego
132)	CSU San Francisco Police Department		San Francisco
133)	CSU San Jose Police Department		San Jose
134)	CSU San Luis Obispo (Cal Poly) Police		San Luis Obispo
135)	CSU San Marcos Police Department		San Marcos
136)	CSU Sonoma Police Department		Rohnert Park

#	PSAP NAME	STATUS	LOCATION
137)	Culver City Police/Fire Department	EP,CP	Culver City
138)	Daly City Police Department		Daly City
139)	Davis Police Department		Davis
140)	Del Norte County Sheriff's Department		Crescent City
141)	Delano Police Department		Delano
142)	Dinuba Police Department		Dinuba
143)	Dos Palos Police Department (Westside		Dos Palos
144)	Downey Fire Department		Downey
145)	Downey Police Department		Downey
146)	East Bay Regional Park District		Castro Valley
147)	El Cajon Police Department		El Cajon
148)	El Camino Community College District Police		Torrance
149)	El Centro Police Department	HS-I	El Centro
150)	El Dorado County Sheriff's Department		Placerville
151)	El Monte Police Department		El Monte
152)	Elk Grove Police Department		Elk Grove
153)	Emeryville Police Department		Emeryville
154)	Escondido Police Department		Escondido
155)	Eureka Police Department		Eureka
156)	Fairfax Police Department		Fairfax
157)	Fairfield Police Department		Fairfield
158)	Firebaugh Police Department		Firebaugh
159)	Folsom Police Department		Folsom
160)	Fontana Police Department		Fontana
161)	Fortuna Police Department		Fortuna
162)	Foster City Police Department		Foster City
163)	Fountain Valley Police Department		Fountain Valley
164)	Fremont Police Department		Fremont
165)	Fresno County EMS		Fresno
166)	Fresno County Sheriff's Department		Fresno
167)	Fresno Police Department		Fresno
168)	Fullerton Police Department		Fullerton
169)	Galt Police Department		Galt
170)	Garden Grove Police Department		Garden Grove
171)	Gilroy Police Communications		Gilroy
172)	Glendale Police Department	EE,CP	Glendale
173)	Glendora Police Department		Glendora
174)	Glenn County Sheriff's Department	CE	Willows
175)	Gridley Police Department	CE, HS-	Gridley
176)	Grover Beach Police Department		Grover Beach
177)	Hanford Police Department		Hanford
178)	Hayward Police Department		Hayward
179)	Healdsburg Police Department		Healdsburg
180)	Heartland Communications Facility Authority -		El Cajon
181)	Hemet Police Department		Hemet
182)	Hillsborough Police Department		Hillsborough

#	PSAP NAME	STATUS	LOCATION
183)	Humboldt County Sheriff's Department		Eureka
184)	Huntington Beach Police Department		Huntington Beach
185)	Huntington Park Police Department		Huntington Park
186)	Huron Police Department		Huron
187)	Imperial County Sheriff's Department	HS-I	El Centro
188)	Indio Police Department		Indio
189)	Inglewood Police/Fire Department		Inglewood
190)	Inyo County Sheriff's Department		Independence
191)	Irvine Police Department		Irvine
192)	Irwindale Police Department		Irwindale
193)	Kern County Fire Department		Bakersfield
194)	Kern County Sheriff's Department		Bakersfield
195)	Kings County Sheriff's Department		Hanford
196)	La Habra Police Department		La Habra
197)	La Mesa Police Department		La Mesa
198)	La Palma Police Department		La Palma
199)	La Verne Police/Fire Department	EP,CP	La Verne
200)	Laguna Beach Police Department		Laguna Beach
201)	Lake County Sheriff's Department		Lakeport
202)	LASD - Carson Sheriff's Station	HS-LAS	Carson
203)	LASD - Century Sheriff's Station	HS-LAS	Lynwood
204)	LASD - Cerritos Sheriff's Station	HS-LAS	Cerritos
205)	LASD - Compton Sheriff's Station	HS-LAS	Compton
206)	LASD - Crescenta Valley Sheriff's Station	HS-LAS	La Crescenta
207)	LASD - East Los Angeles Sheriff's Station	HS-LAS	Los Angeles
208)	LASD - Industry Sheriff's Station	HS-LAS	City of Industry
209)	LASD - Lakewood Sheriff's Station	HS-LAS	Lakewood
210)	LASD - Lancaster Sheriff's Station	HS-LAS	Lancaster
211)	LASD - Lomita Sheriff's Station	HS-LAS	Lomita
212)	LASD - Lost Hills/Malibu Sheriff's Station	HS-LAS	Calabasas
213)	LASD - Marina Del Rey Sheriff's Station	HS-LAS	Marina Del Rey
214)	LASD - Metro Transportation Authority	HS-LAS	Los Angeles
215)	LASD - Norwalk Sheriff's Station	HS-LAS	Norwalk
216)	LASD - Palmdale Sheriff's Station	HS-LAS	Palmdale
217)	LASD - Pico Rivera Sheriff's Station	HS-LAS	Pico Rivera
218)	LASD - San Dimas Sheriff's Station	HS-LAS	San Dimas
219)	LASD - Santa Clarita Valley Sheriff's Station	HS-LAS	Valencia
220)	LASD - South Los Angeles Sheriff's Station	HS-LAS	Los Angeles
221)	LASD - Temple City Sheriff's Station	HS-LAS	Temple City
222)	LASD - Walnut/Diamond Bar Sheriff's Station	HS-LAS	Walnut
223)	LASD - West Hollywood Sheriff's Station	HS-LAS	Los Angeles
224)	Lassen County Sheriff's Department	CE	Susanville
225)	Lincoln Police Department	HS-P	Lincoln
226)	Lindsay Police Department		Lindsay
227)	Livermore Police Department		Livermore
228)	Livingston Police Department		Livingston

#	PSAP NAME	STATUS	LOCATION
229)	Lodi Police Department		Lodi
230)	Lompoc Police Department		Lompoc
231)	Long Beach Fire Department		Long Beach
232)	Long Beach Police Department		Long Beach
233)	Los Altos Police Department	HS-SC	Los Altos
234)	Los Angeles City Fire Department		Los Angeles
235)	Los Angeles County Fire		Los Angeles
236)	Los Angeles Police Department		Los Angeles
237)	Los Banos Police Department		Los Banos
238)	Los Gatos Police Communications		Los Gatos
239)	Madera County Sheriff		Madera
240)	Madera Police Department		Madera
241)	Manteca Police Department		Manteca
242)	Marin County Fire Department		Woodacre
243)	Marin County Sheriff's Department		San Rafael
244)	Mariposa County Sheriff's Department		Mariposa
245)	Martinez Police Department		Martinez
246)	Marysville Police Department	CE	Marysville
247)	McFarland Police Department		McFarland
248)	Mendocino County Sheriff's Department	EE,CP	Ukiah
249)	Menlo Park Police Department		Menlo Park
250)	Merced County Sheriff's Department		Merced
251)	Merced Emergency Medical Services		Merced
252)	Merced Police Department		Merced
253)	MetroNet - Metro Cities Fire Authority Comm.		Anaheim
254)	Milpitas Police Department		Milpitas
255)	Modoc County Sheriff's Department	CE	Alturas
256)	Mono County Sheriff's Department		Bridgeport
257)	Monrovia Police Department	EP,CP	Monrovia
258)	Montclair Police Department		Montclair
259)	Montebello Police Department	EP,CP	Montebello
260)	Montecito Fire Protection District		Montecito
261)	Monterey County Emergency Communications		Salinas
262)	Monterey Park Police/Fire Department	EP,CP	Monterey Park
263)	Morgan Hill Police Communications		Morgan Hill
264)	Mountain View Police/Fire Department	HS-SC	Mountain View
265)	Mt. Shasta Police Department	CE	Mt Shasta
266)	Murrieta Police Department		Murrieta
267)	Napa County Communications		Napa
268)	NASA AMES Police Department		Moffett Field
269)	National City Police Department		National City
270)	Nevada County Sheriff's Department		Nevada City
271)	Newark Police/Fire Department		Newark
272)	Newport Beach Police Department		Newport Beach
273)	North County Dispatch		Rancho Santa Fe
274)	Novato Police Department		Novato

#	PSAP NAME	STATUS	LOCATION
275)	Oakdale Police Department		Oakdale
276)	Oakland Fire Department		Oakland
277)	Oakland Police Department		Oakland
278)	Oceanside Police Department		Oceanside
279)	Ontario Fire Department		Ontario
280)	Ontario Police Department		Ontario
281)	Orange County Fire Authority		Irvine
282)	Orange County Sheriff's Department (Harbor		Corona Del Mar
283)	Orange County Sheriff's Department		Silverado
284)	Orange Police Department		Orange
285)	Oroville Police Department	CE, HS-	Oroville
286)	Oxnard Police/Fire Department	CP, HS-	Oxnard
287)	Palm Springs Police/Fire Department		Palm Springs
288)	Palo Alto Police Department	HS-SC	Palo Alto
289)	Palos Verdes Estates Police/Fire Department		Palos Verdes
290)	Paradise Police Department	CE, HS-	Paradise
291)	Pasadena Police Department	EE,CP	Pasadena
292)	Paso Robles Police Department		Paso Robles
293)	Petaluma Police Department		Petaluma
294)	Piedmont Police Department		Piedmont
295)	Pinole Police Department		Pinole
296)	Pismo Beach Police Department		Pismo Beach
297)	Placentia Police Department		Placentia
298)	Placer County Sheriff's Department	HS-P	Auburn
299)	Placerville Police Department		Placerville
300)	Pleasant Hill Police Department		Pleasant Hill
301)	Pleasanton Police Department		Pleasanton
302)	Plumas County Sheriff's Department	CE	Quincy
303)	Pomona Police Department	EP,CP	Pomona
304)	Port Hueneme Police Department		Port Hueneme
305)	Porterville Police Department		Porterville
306)	Red Bluff Police Department	CE	Red Bluff
307)	Redlands Police Department		Redlands
308)	Redondo Beach Police/Fire Department		Redondo Beach
309)	Redwood City Police Department		Redwood City
310)	Reedley Police Department		Reedley
311)	Rialto Police Department		Rialto
312)	Richmond Police Department		Richmond
313)	Ridgecrest Police Department		Ridgecrest
314)	Ripon Police Department		Ripon
315)	Riverside County Sheriff's Department	HS-R	Blythe
316)	Riverside County Sheriff's Department	HS-R	Palm Desert
317)	Riverside County Sheriff's Department	HS-R	Riverside
318)	Riverside Police Department		Riverside
319)	Rocklin Police Department	HS-P	Rocklin
320)	Rohnert Park Police Department		Rohnert Park

#	PSAP NAME	STATUS	LOCATION
321)	Roseville Police Department	HS-P	Roseville
322)	Sacramento City Police Department		Sacramento
323)	Sacramento County Sheriff's Department		Elk Grove
324)	Sacramento Regional Fire Emergency Comm.		Sacramento
325)	San Bernardino County Sheriff's Department		Rialto
326)	San Bernardino County Sheriff's Department		Hesperia
327)	San Bernardino Police Department		San Bernardino
328)	San Bruno Police Department		San Bruno
329)	San Diego County Lifeguards		San Diego
330)	San Diego County Sheriff's Department		San Diego
331)	San Diego Fire Communications		San Diego
332)	San Diego Harbor Police Department		San Diego
333)	San Diego Police Department		San Diego
334)	San Fernando Police Department	EP,CP	San Fernando
335)	San Francisco Dept. Emergency Management		San Francisco
336)	San Francisco International Airport Police		South San
337)	San Gabriel Police Department	EP,CP	San Gabriel
338)	San Joaquin County Sheriff's Department		French Camp
339)	San Jose Police/Fire Communications		San Jose
340)	San Leandro Police Department		San Leandro
341)	San Luis Obispo County Sheriff's Department		San Luis Obispo
342)	San Luis Obispo Police Department		San Luis Obispo
343)	San Marino Police Department	EP,CP	San Marino
344)	San Mateo County Communications		Redwood City
345)	San Mateo Police Department		San Mateo
346)	San Rafael Police Department		San Rafael
347)	San Ramon Valley Fire Protection District		San Ramon
348)	Santa Ana Police Department		Santa Ana
349)	Santa Barbara County Sheriff's Department		Santa Barbara
350)	Santa Barbara Police Department		Santa Barbara
351)	Santa Clara County Sheriff's Department		San Jose
352)	Santa Clara Police Department		Santa Clara
353)	Santa Cruz Regional 9-1-1		Santa Cruz
354)	Santa Maria Police Department		Santa Maria
355)	Santa Monica Police Department		Santa Monica
356)	Santa Paula Police Department		Santa Paula
357)	Santa Rosa Police Department		Santa Rosa
358)	Scotts Valley Police Department		Scotts Valley
359)	Sebastopol Police Department		Sebastopol
360)	Selma Police Department		Selma
361)	Shafter Police Department		Shafter
362)	Shasta County Comm. Center - SHASCOM	CE	Redding
363)	Sierra County Sheriff's Department	CE	Downieville
364)	Sierra Madre Police/Fire Department	EE,CP	Sierra Madre
365)	Signal Hill Police Department		Signal Hill
366)	Simi Valley Police Department	CP, HS-	Simi Valley

#	PSAP NAME	STATUS	LOCATION
367)	Siskiyou County Sheriff's Department		Yreka
368)	Solano County Sheriff		Fairfield
369)	Sonoma County REDCOM Fire & EMS		Santa Rosa
370)	Sonoma County Sheriff's Department		Santa Rosa
371)	Sonora Police Department		Sonora
372)	South Bay Regional Public Comm. Authority		Hawthorne
373)	South Gate Police Department		South Gate
374)	South Lake Tahoe Police Department		South Lake Tahoe
375)	South Pasadena Police/Fire Department	EP,CP	South Pasadena
376)	South San Francisco Police Department		South San
377)	St. Helena Police Department		St. Helena
378)	Stanislaus Regional 9-1-1		Modesto
379)	Stockton Fire Department		Stockton
380)	Stockton Police Department		Stockton
381)	Suisun City Police Department		Suisun
382)	Sunnyvale Police Department		Sunnyvale
383)	Sutter County Sheriff's Department	CE	Yuba City
384)	Taft Police Department		Taft
385)	Tehama County Sheriff's Department	CE	Red Bluff
386)	Torrance Police Department		Torrance
387)	Tracy Police Department		Tracy
388)	Trinity County Sheriff's Department	CE	Weaverville
389)	Tulare County Consol. Ambulance Dispatch -		Tulare
390)	Tulare County Fire Department		Farmersville
391)	Tulare County Sheriff's Department		Visalia
392)	Tulare Police Department		Tulare
393)	Tuolumne County Sheriff's Department		Sonora
394)	Turlock Police Department		Turlock
395)	UC Berkeley Police Department		Berkeley
396)	UC Davis Police Department		Davis
397)	UC Irvine Police Department		Irvine
398)	UC Los Angeles Police Department		Los Angeles
399)	UC Merced Police Department		Merced
400)	UC Riverside Police Department		Riverside
401)	UC San Diego Police Department		La Jolla
402)	UC San Francisco Police Department		San Francisco
403)	UC Santa Barbara Police Department		Santa Barbara
404)	UC Santa Cruz Police Department		Santa Cruz
405)	Ukiah Police Department	EE,CP	Ukiah
406)	Union City Police Department		Union City
407)	Upland Police Department		Upland
408)	US Air Force Beale AFB SFCC		Beale AFB *
409)	US Air Force Edwards AFB Fire Department		Edwards AFB
410)	US Air Force Travis AFB		Travis AFB
411)	US Air Force Vandenberg AFB Police/Fire		Vandenberg AFB
412)	US Army Fort Hunter Liggett Police		Ft Hunter Liggett

#	PSAP NAME	STATUS	LOCATION
413)	US Army Fort Irwin Provost Marshall (MP)		Fort Irwin
414)	US Army Presidio of Monterey Dispatch		Presidio of
415)	US Park Police Golden Gate NRA		San Francisco
416)	US Sequoia National Park		Three Rivers
417)	US Yosemite National Park		El Portal
418)	USMC Camp Pendleton JECC		Camp Pendleton
419)	USMC Logistics Base Barstow - NEBO		Barstow
420)	USMC Miramar Air Station Police/Fire Dept.		San Diego
421)	USMC Twenty-Nine Palms Combat Center -		Twenty-Nine Palms
422)	Vacaville Police Department		Vacaville
423)	Vallejo Police Department		Vallejo
424)	Valley Regional Emergency Communications		Modesto
425)	Ventura County Fire Protection District		Camarillo
426)	Ventura County Sheriff's Department	CP, HS-	Ventura
427)	Ventura Police Department		Ventura
428)	Verdugo Fire Department	EE,CP	Glendale
429)	Vernon Police Department		Vernon
430)	Visalia Police Department		Visalia
431)	Walnut Creek Police Department		Walnut Creek
432)	Weed Police Department	CE	Weed
433)	West Covina Police/Fire Department	EP,CP	West Covina
434)	WEST-COMM - West Cities Police Comm		Seal Beach
435)	Westminster Police Department		Westminster
436)	Whittier Police Department		Whittier
437)	Willits Police Department	EE,CP	Willits
438)	Willows Fire Department	CE	Willows
439)	Yolo Emergency Communications Agency		Woodland
440)	Yreka Police Department	CE	Yreka
441)	Yuba City Police Department	CE	Yuba City
442)	Yuba County Sheriff's Department	CE	Marysville

#### 1.4. TERM/PERIOD OF PERFORMANCE

- 1) Effective upon approval of the California Department of Technology (CDT), Statewide Technology Procurement (STP), the initial Multiple Award Contract term will be three (3) years.
- 2) Cal OES, at its sole discretion, may exercise its option to execute four (4), one (1)-year extensions for a maximum Multiple Award Contract term of seven (7) years.
- 3) The Contractor shall not be authorized to deliver goods or commence the performance of services as described in this SOW until written approval has been obtained from all entities. Any delivery or performance that is commenced prior to the signing of the multiple award contracts shall be considered voluntary on the part of the Contractor and non-compensable.
- 4) Amendments may occur at any time, consistent with the Terms and Conditions of the Multiple Award Contract and by mutual consent of both parties, subject to approval by the STP under Public Contract Code (PCC) 12100.
- 5) Period of performance for a PSAP's CPE purchase will continue for the five (5) years, consisting of a one (1) year warranty and four (4) years maintenance included in the purchase price, from the date of system acceptance. The Contractor shall adhere to this Period of Performance even when the multiple award contract term may have expired.
- 6) If the Contractor receives a CPE request from the PSAP, the Contractor must coordinate with the PSAP to ensure sufficient time to develop a PO Package. A PSAP's PO Package (as described within the CA 9-1-1 Branch Operations Manual Chapter 3 – Funding) must be received by the CA 9-1-1 Branch at a minimum of four (4) weeks prior the Multiple Award Contract expiration to allow time for review, revision, and issuance of a TD-288 Commitment to Fund.
- 7) The Contractor is required to respond to the PSAP's request for additional CPE monthly maintenance (beyond original purchases five (5) year maintenance term) by providing a quote not to exceed the Cost Workbook pricing in Exhibit 16. Quote must be provided with sufficient lead time to allow PSAP's submittal of required PO to the CA 9-1-1 Branch at a minimum of four (4) weeks prior to expiration of the Multiple Award Contract.
- 8) If the Contractor subsequently receives PSAP's submittal of PO and the CA 9-1-1 Branch's TD-288 Commitment to Fund additional CPE monthly maintenance, Period of Performance shall continue on a monthly basis for up to an additional twenty-four months (until acceptance of subsequent CPE replacement; or upon PSAP request for termination with thirty days' notice to the Contractor) even if the Multiple Award Contract may have expired.

- 9) After the multiple award contract expiration date, new orders shall not be issued and are prohibited.

**1.5. PROJECT REPRESENTATIVES**

The project representatives during the term of this Agreement will be:

**Table 1-2 PROJECT REPRESENTATIVES**

<p><b>State:</b> California Governor's Office of Emergency Services</p> <p><b>Name:</b> Alicia Fuller Contract Manager</p> <p><b>Address:</b> 601 Sequoia Pacific Blvd. Sacramento, CA 95811</p> <p><b>Phone:</b> (916) 657-6119</p> <p><b>Fax:</b></p> <p><b>e-mail:</b> <a href="mailto:Alicia.Fuller@caloes.ca.gov">Alicia.Fuller@caloes.ca.gov</a></p>	<p><b>Contractor:</b></p> <p><b>Name:</b> Henry Wang</p> <p><b>Address:</b> 3707 Kings Way Room 33 Sacramento, CA 95821</p> <p><b>Phone:</b> (213) 422-1152</p> <p><b>Fax:</b> (714) 441-0824</p> <p><b>e-mail:</b> <a href="mailto:Hw3126@att.com">Hw3126@att.com</a></p>
--	--

Direct all contract inquiries to:

<p><b>State:</b> CA Governor's Office of Emergency Services</p> <p><b>Unit:</b> Procurement and Logistics Services Branch</p> <p><b>Attention:</b> Phuong Vu Contracts Analyst</p> <p><b>Address:</b> 3650 Schriever Ave Mather, CA 95655</p> <p><b>Phone:</b> (916) 845-8190</p> <p><b>Fax:</b> (916) 845-8303</p> <p><b>e-mail:</b> <a href="mailto:Phuong.Vu@caloes.ca.gov">Phuong.Vu@caloes.ca.gov</a></p>	<p><b>Contractor:</b></p> <p><b>Attention:</b> Henry Wang</p> <p><b>Address:</b> 3707 Kings Way Room 33 Sacramento, CA 95821</p> <p><b>Phone:</b> (213) 422-1152</p> <p><b>Fax:</b> (714) 441-0824</p> <p><b>e-mail:</b> <a href="mailto:Hw3126@att.com">Hw3126@att.com</a></p>
--	---

**1.6. CONTRACTOR RESPONSIBILITIES**

The Contractor shall:

- 1) Ensure that installation of equipment includes all parts, labor, software and configuration required to deliver and make the system ready for use, and operational with the manufacturer's published specifications.
- 2) Provide period of performance one (1) year Warranty and four (4) years Maintenance on any system purchased prior to contract termination.
- 3) Designate a primary contact person to whom all project communications may be addressed and who has the authority to act on all aspects of the services.

- 4) Notify Cal OES, in writing, of all changes in the personnel assigned to the tasks. If a Contractor employee is unable to perform due to illness, resignation, or other factors beyond the Contractor's control, the Contractor will provide suitable substitute personnel. The substitute personnel shall meet all requirements and must be approved in advance of any performance under the Agreement by Cal OES via an approved Amendment if adding a new subcontractor.
- 5) Perform their duties on the premises of the PSAP facilities located within California, during the best available hours for the PSAP, and at all other times as required to successfully provide the services.
- 6) Comply with the PSAP's requirements that restrict deliveries to non-peak commute hours in specific locations, or require delivery within defined time frames due to site policies. When applicable, the PSAP will provide the information regarding these policies/or requirements.
- 7) Provide the PSAP with a copy of the manufacturer's recommended preventive maintenance process and schedule. Preventive (scheduled) maintenance shall be performed in accordance with the manufacturer's recommended preventive maintenance requirements and be consistent with the PSAP's operating requirements.
- 8) Work closely with PSAPs regarding any of the additional applications and peripheral equipment provided under contract and adhere to any changes and future time-frames listed in the individual requirements.
- 9) Allow equipment purchased under the Contract to be operated at any time, for any length of time at the convenience of the PSAP, exclusive of the time required for preventive and remedial maintenance.
- 10) Allow each item of software that is proprietary in nature to be licensed to the PSAP for its use in accordance with the provisions of the Contract and the PSAP shall have unrestricted use of the software.
- 11) Provide title to equipment, accessories and devices purchased under the Contract shall be vested in the PSAP.
- 12) Make every reasonable effort to assist the PSAP in procuring the use of equipment compatible with that provided under this Contract to meet emergencies such as major outages or unforeseen peak loads. The PSAP may accept or reject the offer of use of emergency equipment. If accepted the charge for such use, if any, shall be a separate Purchase Order (PO) arrangement between the PSAP and the Contractor.

13)The Contractor will, within five (5) State business days after initial problem notification, respond to Cal OES by submitting a detailed explanation describing precisely how the identified services and/or products actually adhere to and satisfy all applicable requirements, and/or a proposed corrective action plan to address the specific inadequacies and/or failures in the identified services and/or products. Failure by the Contractor to respond to Cal OES's initial problem notification within the required time limits may result in immediate termination of the Contract. In the event of such termination, Cal OES shall pay all amounts due the Contractor for all work accepted prior to termination.

14)Submit a system diagram, depicting data flow and interconnection requirements.

15)As the Prime, be responsible for all the terms and conditions of this Contract regardless if a failure occurs in any portion of their system or their Subcontractors.

### **1.6.1. Labor Classifications**

Contractor shall make available each of the labor classifications listed below. Pricing for these classifications shall be provided in Exhibit 16 Cost Worksheet #2, Labor Rates. For each labor classification all individuals used by the Contractor through teaming agreements or sub-contracting arrangements shall meet these following requirements:

#### **1.6.1.2. Factory-Trained Technician**

The definition of a Factory-Trained Technician is a technician who has passed a certification/training course taught by factory or factory approved personnel for the system he/she must install and maintain. All training courses provided by other than the manufacturer's own personnel must be recognized and approved by the manufacturer, if the Contractor asserts that an employee is factory-trained. A Factory-Trained Technician is able to diagnose all Major and Minor system alarms, provide hardware and software repairs, provide to the PSAP recommendations regarding user defined software and make changes to the user defined software. Contractor shall provide proof of Factory-Trained Technician certification upon use of this labor classification to the State.

#### **1.6.1.3. Technician**

The definition of Technician is a person who has basic telephone skills that has been provided instruction by a Certified Factory-Trained Technician for the system he/she must maintain at a level that the Technician is able to view all Major and Minor system alarms, provide hardware replacements and software repairs and provide to the PSAP recommendations regarding user defined software, under the direction of a Certified Factory-Trained Technician. Contractors shall detail the training that will be provided to a Technician.

#### **1.6.1.4. System Engineer**

For the purposes of the resulting Contract, a System Engineer is a person that has at least three (3) years' experience in 9-1-1 applications for CPE call-taking systems. A System

Engineer shall be capable of engineering all of the systems that that the Contractor proposes or sells through the resulting Contract.

#### **1.6.1.5. Project Manager**

A Project Manager shall have provided project management support on behalf of a 9-1-1 emergency call processing system provider for at least three (3) distinct installations. Full time support of another Project Manager on an installation may be considered to meet this experience requirement. The Project Manager will act as the single point of contact to the PSAP manager (or their designee) and will be available to the PSAP manager during the implementation of a new system and will be on-site during cutover to the new system.

### **1.7. ORDERING PROCESS**

Following the 9-1-1 CPE System PSAP User Instructions, PSAPs will submit orders accordingly. The ordering process that the CA 9-1-1 Branch uses is detailed in the 9-1-1 Operation Manual, Chapter III, Funding. The Operations Manual can be viewed at:

<http://www.Cal OES.ca.gov/for-businesses-organizations/plan-prepare/ca-9-1-1-operations-manual>

#### **1.7.1. 9-1-1 CPE System Diagrams**

As part of the ordering process for the 9-1-1 CPE Turn-key or Host-Remote System, the Request for Offers (RFOs) to the PSAPs shall include system diagrams using Microsoft Visio or similar to depict:

- 1) System connectivity;
- 2) Data flow;
- 3) Interconnection Requirements;
- 4) System NG9-1-1 functionality including connectivity to network (if necessary);
- 5) IWS equipment;
- 6) PC hardware Requirements;
- 7) Interfaces to any PSAP auxiliary equipment (i.e. CAD, log recorder);
- 8) Interfaces to any PSAP Itemized Items;
- 9) Interfaces to any peripheral equipment ordered

## **1.7.2. Examples of System Orders using Price Worksheets**

### **1.7.2.1. 9-1-1 CPE Turn-key Example**

A PSAP requiring an individual Turn-key System with five (5) positions would simply use the Price Worksheet Tab #1 of Exhibit 16, Line Item #4. A PSAP requiring an individual Turn-key System with 25 positions would select one (1) unit from Line #19, and five (5) units from Line #20. A PSAP with an individual Turn-key System already installed that requires an additional three (3) IWSs, would select three (3) units from Line #21.

### **1.7.2.2. Itemized Example**

A PSAP requiring any itemized item from the Itemized Price Worksheet, Tab #2 of Exhibit 16 would simply select their unit of measure for each item desired. PSAPs requiring larger sized monitors would select the appropriate itemized Line Item, #s 3 or 4, and then the monitor in the 9-1-1 Turn-key or Host-Remote System would be discounted. A PSAP requiring additional Legacy Network capacity for CAMA or 10-digit would use Line #5. PSAPs converting to an IP Network would select the IP Interface Gateway/Appliance from Line # 6. A PSAP who has their own UPS for backroom equipment or a small units at the IWSs, will expect, at a minimum, the unit price listed on Line #s 8 and 9 shall be discounted from the 9-1-1 Turn-key or Host-Remote System.

### **1.7.2.3. 9-1-1 CPE Host-Remote Example**

Host-Remote Systems with multiple Remote PSAPs will use the Price Worksheet on Tab #3 of Exhibit 16. A Host-Remote System with two (2) Remote PSAPs with two (2) positions each and two (2) Remote PSAPs with five (5) positions each would select one (1) unit from Line #1 for the first Host, one (1) unit from Line #2 for the second Host, two (2) units from Line #4 and, two (2) units from Line #7. At the time of installation, if the Host-Remote System required a Remote PSAP with 24 positions, one (1) unit from Line #22 and four (4) units from Line #23. After initial installation, if the Host-Remote System needed an additional position at the two (2) PSAPs with two (2) positions, they would select two (2) units from Line #24 is selected. After the initial installation, if the Host-Remote System needs to expand and add an additional Remote PSAP, with six (6) positions they would select one (1) unit from Line #8, and two (2) units from Line #25 to add another PSAP to each Host.

The host server of the Host-Remote System is priced for the host not installed at a PSAP. If a Host-Remote System is designed to have a host server at a PSAP, then the Contractor may discount the price on the order.

## **1.8. UNPLANNED DOWN-TIME DISCLOSURE AND ROOT CAUSE ANALYSIS**

In the event CPE equipment is impacted by unplanned down-time, (such as a failure), the Contractor shall provide the CA 9-1-1 Branch and PSAPs with a written disclosure statement within two (2) calendar weeks via email which shall include but not be limited to:

- 1) The component that failed;
- 2) The duration (including start time and end time) the component was impacted;

- 3) Impact to the overall system due to the component failure – including impacted PSAPs by Federal Communications Commission (FCC) Identification (ID); and
- 4) Corrective action taken to recover the component.

The disclosure statement shall be provided by the Contractor proactively without request from Cal OES and/or the Local Agency/Agencies.

In addition to the above disclosure the Contractor shall provide a root cause analysis to the CA 9-1-1 Branch and Local Agency/Agencies within 15 business days. If a complete root cause analysis cannot be provided the Contractor shall provide an initial root cause analysis within 15 business days and then update the CA 9-1-1 Branch and PSAPs every five (5) business days until root cause is determined.

Root cause analysis shall identify the root cause of failure and corrective action to prevent a like failure in the future.

## **1.9. INSTALLATION DATE**

A PSAP is a Public Agency authorized under Government Code Section 53102 to perform the functions of a PSAP. Orders from the PSAP must be completely installed and ready-for-use within 180 calendar days After Receipt of Order (ARO) as indicated on the PO.

The installation date may be changed by mutual consent of the Contractor and the PSAP; however, the System Installation Schedule must be completed/updated with the revised dates. Such deferment shall not exceed 60 calendar days, except by mutual agreement. In the event of an agreed change to the installation date, the Contractor will provide a revised Contractor's SOW to the PSAPs and to the CA 9-1-1 Branch.

### **1.9.1. Restricted Delivery Hours**

The Contractor shall comply with the PSAP's requirements that restrict deliveries to non-peak commute hours in specific locations, or require delivery within defined time frames due to site policies. When applicable, the PSAP will provide the information regarding these policies/or requirements.

### **1.9.2. Site Survey**

As part of the RFO for the PSAP, the Contractor shall prepare a floor plan of the Communications Operations Room showing the location of each item of equipment and detailing the current electrical power, common ground and environmental control facilities. The Contractor shall prepare a floor plan of the Equipment Room showing the location of each item of back-room equipment and detailing the current electrical power and environmental control facilities. The Contractor shall review and comment on the adequacy of the PSAP's facility, including but not limited to, the adequacy of the furniture, lighting, floor plan, environmental control, cabling, demarcation room and equipment room to support the installation of the 9-1-1 system. The PSAP shall permit free access, subject to security restrictions at the site, for the purpose of reviewing facility readiness.

Specifications shall include the operating voltage required, maximum current under peak conditions (in amperes), power consumed (expressed in watts), temperature range within which the equipment is designed to operate, the humidity range within which the equipment offered is designed to operate, grounding required, the equipment heat producing pattern under normal operating conditions (expressed in British Thermal Units (BTUs) for each specific Model Cluster), and the type and number of power receptacles required. All modifications specified to prepare the facilities must be detailed in the Contractor's SOW.

The Contractor shall provide a pre-installation checklist to insure that the PSAP has met all installation obligations prior to the Contractor installing the equipment. Absence of a pre-installation checklist shall mean that the Contractor is offering equipment that has no Minimum or maximum environmental specifications.

On or before the Facility Readiness Date, the PSAP shall cause the site to be prepared in accordance with the Contractor's site preparation specifications unless the Contractor has agreed to be responsible for such site preparation. The Contractor will provide a written certification that the modifications detailed on the pre-installation checklist have been completed in accordance with the Contractor's requirements.

Subsequent alterations or modifications to the site which are directly attributable to incomplete or erroneous specifications provided by the Contractor and which involve additional expense shall be made at the expense of the Contractor, to the extent that such costs would not have been incurred had the complete and/or correct specifications been initially provided. If such site alterations cause a delay in the installation, the provisions of Section 1.17, Attachment 1.0, Contractor's Monthly Activity Report and Section 1.16 shall apply.

### **1.9.3. Certification of Facility Readiness**

If required, Cal OES and/or PSAP will modify PSAP site facilities to meet the Contractor's specifications at Cal OES and/or PSAP expense. Upon completion the Contractor will be required to certify in writing that the modifications have been completed and satisfy the Contractor's requirements before delivery.

### **1.9.4. Certification of Equipment Readiness**

Equipment must be installed and certified ready for acceptance testing by the agreed to installation date and Acceptance Test Plan between the Contractor and PSAP. Such certification must be in writing and presented to the individual specified in Attachments 3.0 and 3.1, Contractor's Sample Statement of Work.

### **1.9.5. Relocation**

Relocation refers to a PSAP moving to a different location on a long-term basis. This includes packing up all CPE and associated equipment purchased under this contract and transporting to another location and reinstalling it for operational use.

- 1) If it is necessary and in the best interest of the PSAP to move the equipment purchased under this Contract from a PSAP location to another, except in an emergency situation, the PSAP will notify the Contractor in writing or electronically, a minimum of six (6) months in

advance of the anticipated move date, that the move is scheduled to take place. The PSAP will provide their PO number, date of disconnection, the locations from and to where the equipment is to be moved, and the re-connection date, if more than five (5) business days after the disconnect date. The Contractor and PSAP will mutually agree on a reasonable amount of time to accomplish disconnection, relocation, reconnection and having the equipment ready for use. Cal OES will only pay for 30 days of overlapping network costs. After 30 days is exceeded, billing from vacated PSAP premises will be transferred and become the responsibility of the PSAP. Confer with CA 9-1-1 Branch current Operations Manual policy.

- 2) The PSAP will reimburse the Contractor for all transportation, transit, risk insurance, rigging, packing, unpacking and drayage charges for such relocation performed by the Contractor; however, the Contractor shall maintain responsibility for the equipment at all times during the move.
- 3) If the Contractor does not relocate the equipment by the mutually agreed date, the SLAs, as specified in Section 1.17.1, System Readiness: Hardware and Software, shall apply. Contractors should note that the SLAs shall be the same as for late deliveries.
- 4) On, or before, the scheduled reconnect date, the Contractor shall disconnect affected equipment, physically move (relocate) and reconnect and certify the equipment at the new location.
- 5) In the case of an emergency PSAP CPE relocation, all noted timelines are subject to negotiation on a case-by-case basis with the Contractor.
- 6) Rearrangement of equipment at a single site or for the convenience of the PSAP, shall be at the PSAP's expense. If the Contractor is asked to move and reinstall equipment at a different facility, the Contractor shall not exceed the hourly Labor Rates bid in Exhibit 16. However, the cost for other services not normally associated with a same facility MACs, such as moving van equipment and personnel, will be negotiated between the Contractor and PSAP on a case-by-case basis for each re-location.

#### **1.9.6. Moves, Adds and Changes (MACS)**

MACs refers to changes in system application configurations to facilitate PSAP operations or moving equipment from one location to another in the same facility or adding additional equipment to completed installations.

- 1) The Contractor shall provide routine MACs as requested by the PSAP. When performing MACs, the Contractor will not bill for travel time to and from the PSAP or preparation time, only the time spent actually performing the MACs.

- 2) There shall be a one (1) hour minimum charge for all MACs. For those MACs that are performed routinely, such as adding or deleting new Telecommunicator Intelligent Workstations (IWSs), changing speed dial numbers, etc., the Contractor shall provide training to the PSAP System Administrator when performing these MACs.
- 3) Contractor shall detail the process for the PSAP to request routine MACs, how the Contractor will perform on-site versus off-site MACs and the anticipated turn-around time to completion, each time a request is made. All routine MACs shall be accomplished within a mutually agreed upon number of days from the date request is submitted to the Contractor.
- 4) All costs for MACs will be directly billed to and paid by the PSAP, not to exceed the hour Labor Rates bid in Exhibit 16. If the contractor is asked to move and reinstall equipment at a different facility, the Labor Rates established by this Contract will apply to similar activities performed, such as those described above, while the cost for other services not normally associated with a same facility MAC, such as moving van equipment and personnel, may be negotiated on case-by-case basis for each relocation.

#### **1.9.7. Documentation**

The Contractor shall provide copies of all non-proprietary manuals and other printed materials, including updated versions, which are useful and necessary to the PSAP in its use of the equipment or software provided at prices listed in Exhibit 16, Cost Workbook. Contractor shall provide one (1) hard copy and one (1) softcopy for multiple distributions and Web access to updates.

#### **1.10. FREIGHT**

##### **1.10.1. Transportation**

- 1) Shipments to and from the installation site shall be the responsibility of the Contractor. Equipment shall be transported by commercial carrier, or Contractor owned carrier, in a padded van or air freight.
- 2) Equipment shall be preserved, packed and marked in accordance with the Contractor's standard practice. All deliveries of purchased equipment and software shall be Freight on Board (F.O.B.) - DESTINATION.
- 3) The Contractor shall bear the cost of transportation, rigging, and/or drayage whenever equipment is shipped or moved for mechanical replacement purposes.
- 4) The Contractor shall dispose of any packing material and debris. Post installation, the Contractor shall pay transportation charges for the removal of empty packing cases.
- 5) Upon notification, as stipulated in the Section 1.9.5, the PSAP reserves the option, with concurrence from the Contractor (such concurrence not to be unreasonably withheld), to arrange and pay for all transportation, rigging and drayage charges for such relocation.

The PSAP shall use a commercial carrier with a padded van properly constructed and equipped for shipment of electronic equipment. Any subsequent moves are not paid by Cal OES, but may be negotiated between PSAP and Contractor, when the equipment is moved from one PSAP location to another.

### **1.10.2. Packing and Unpacking**

- 1) Supervision of packing, unpacking and placement of equipment shall be furnished by the Contractor during the Contractor's normal working hours without additional charge to the PSAP.
- 2) Rearrangement of equipment on the same site for PSAP convenience shall be at PSAP expense.

### **1.10.3. Risk of Loss or Damage**

The PSAP shall be relieved from all risk of loss or damage to the equipment purchased under this Contract during periods of transportation, installation and during the entire time the equipment is in the possession of the Contractor, except when such loss or damage is due to the fault or negligence of the PSAP. Loss or damage not due to the fault or negligence of the PSAP shall be verified through a legal claims record such as a police or fire report. The PSAP assumes risk of loss or damage for equipment after formal Acceptance of installed systems.

### **1.10.4 Acceptance Testing and Continuing Standard of Performance Acceptance Testing Criteria**

- 1) The Contractor shall issue a certificate of system readiness to the PSAP when equipment and software are installed and ready for acceptance testing. Acceptance testing shall commence on a date and time mutually agreed upon by the PSAP, within 10 business days, following receipt of the certificate of system readiness and shall end when the equipment and software have met the standard of performance Acceptance Testing Criteria for a period of 240 consecutive hours. Operation of the equipment and software to confirm proper installation shall be considered to be a part of the acceptance test. It is not required that the 240 consecutive hour period expire in order to begin a subsequent acceptance testing period.
- 2) Equipment and software shall not be accepted by the PSAP and no charges will be paid by the PSAP or the CA 9-1-1 Branch until all of the items on Attachment 4.0, 9-1-1 CPE System Acceptance and Authorization Checklist are met. Upon the successful completion of the acceptance testing period and within five (5) business days, the PSAP shall execute the System Acceptance and Authorization Checklist and provide copies to the Contractor and the CA 9-1-1 Branch.
- 3) The standard of performance for acceptance testing is defined as the operation of equipment and/or software at an average level of effectiveness of 99.999% for a period of 240 consecutive hours. For acceptance testing purposes, the average effectiveness level

is a percentage figure determined by dividing the Scheduled Operational Hours (SOH) minus down-time by the SOHs. In addition, the equipment shall operate in at least minimal conformance with the Manufacturer's official published specifications applicable to such equipment on the date of this Contract. The Contractor shall provide the published specifications applicable to each piece of equipment, if requested by the PSAP.

- 4) Down-Time, for acceptance testing purposes is that period of time when the system installed at one location is incapable of performing all of the functions for which the installation was intended (during SOH), due to a malfunction of the system or its operating software, excluding all external factors. During a period of system down-time, all equipment and software that are part of the system shall be made available to the Contractor to facilitate prompt repair. During this time the PSAP may use operable equipment and software where such use does not interfere with the Contractor's efforts to restore service and where Contractor's permission for such use is given (such permission not to be unreasonably denied). In the event that the system is required by the Contractor for testing or exercising of failed equipment but is not made available by the PSAP when requested, system down-time shall not accrue during the interval between the time of Contractor's request and the time that the system is made available to the Contractor.
- 5) The required effectiveness level shall apply separately to a system and to each Contractor's supplied remote equipment unless the PSAP and the Contractor agree otherwise. The effectiveness level of the system supplied by the Contractor shall be computed to exclude Down-Time attributable to equipment, cables and wires not supplied by the Contractor.
- 6) If the PSAP uses the system when the system or subsystem is down, as Down-Time is defined above, use of the system shall be excluded from the level of effectiveness computation, as will any down time resulting from system failure during such use.
- 7) The PSAP shall maintain appropriate records to validate that all requirements of this section concerning acceptance testing are met. SOHs and down-time shall be measured in hours and whole minutes. If meters are used to record the time, the meter readings will be converted into hours and whole minutes on a daily basis.
- 8) When a system involves on-line equipment that is remote to the basic installation, the required effectiveness level shall apply separately to the system and to the remote equipment.
- 9) During the acceptance testing period, all the preventative maintenance time shall be excluded from the acceptance testing period hours. System failure down-time shall be measured by those intervals during the acceptance testing period between the time that

the Contractor is notified of the system failure and shall end when the system is returned to the PSAP in operating condition.

- 10) During the acceptance testing period, if the Contractor is notified that the system is not performing as intended, Contractor shall adhere to the response time requirements specified in Remedial Maintenance. All maintenance service and parts shall be furnished by the Contractor without charge during an unsuccessful period of acceptance testing on the same basis as set forth herein concerning maintenance unless such maintenance service and parts are required as a result of the fault or negligence of the PSAP.
- 11) The PSAP may, upon written notice to the Contractor and the CA 9-1-1 Branch that is at least 15 calendar days prior to the scheduled start of the acceptance testing, delay the start of the acceptance testing period, but such delay may not exceed 30 consecutive calendar days. Delays that exceed 30 days shall be referred to the CA 9-1-1 Branch for dispute resolution.
- 12) If the system does not meet the standard of performance within 90 consecutive calendar days after the start of the acceptance testing, the PSAP shall have the option to request a replacement system, extend the performance period or terminate the order (or portions thereof) and seek relief as provided by the Rights and Remedies of State for Default provision in the contract. The PSAP's option shall remain in effect until such time as the system meets the performance criteria, or 180 consecutive calendar days after the start of the acceptance testing, whichever occurs first. If the system has not met the standard of performance by 180 calendar days after installation the PO order under which the defective system is being installed may be cancelled. If the CA 9-1-1 Branch determines the same type of system has not met the standard of performance at more than three (3) planned installations, the system or affected components of the system may be removed from the Contract at the discretion of the CA 9-1-1 Branch.

#### **1.10.5. System Acceptance Testing**

Acceptance testing is intended to ensure that the system acquired operates in substantial accord with the Manufacturer's technical specifications, is adequate to perform as warranted by Contractor's response to the requirements of this Contract and evidences a satisfactory level of performance reliability, prior to its acceptance by the PSAP. If the system to be installed includes operating software as listed in the PO, such operating software shall be present for the acceptance test unless substitute operating software acceptable to the PSAP is provided. Acceptance testing is required for all newly installed technology systems, subsystems and individual equipment which are added, or field modified (modification of equipment from one model to another) after a successful performance period.

The PSAP shall begin acceptance testing on a mutually agreed date and time within 10 business days of a Contractor issuing a certificate of system readiness to the PSAP. If the system fails any portion of acceptance testing, the Contractor shall be notified by the PSAP

immediately of the failure, with written confirmation to be provided in not more than five (5) business days. Control of the system shall immediately be given to the Contractor if the system performs so poorly that it poses a potential threat to public safety and the original 9-1-1 system being replaced is still functional. If the system performs in compliance with this Contract and does not pose a threat to public safety, but does not operate as intended by the manufacturer, the PSAP will continue using the system while the Contractor affects repairs. The system shall not be deemed to be accepted until the Contractor re-certifies such installation and the above referenced test is successfully completed.

In the event the system does not meet the standard of performance during the initial 10 days, the acceptance tests shall continue on an hour -to-hour basis until the standards of performance are met for 10 days. The acceptance-testing period shall not be delayed due to a PSAP request to make a change within a system's featured functionality. All problems that occur during the acceptance testing period that can be quickly remedied by making a change to the system shall only delay the acceptance testing the amount of time from when the problem was first reported to the Contractor to the time the adjustment successfully remedies the problem. Failures during acceptance testing period caused by sources outside of the Contractor's control shall not be deemed as cause to delay the acceptance testing period.

At the request of the Contractor, the PSAP shall make available not only the failed system, but also the equipment that must be utilized by the Contractor to identify the cause of failure and to accomplish the repair.

Systems shall not be accepted by the PSAP or CA 9-1-1 Branch, and no charges associated with such system shall be paid by the PSAP or CA 9-1-1 Branch, until the Contractor has demonstrated that the Contractor has satisfactorily provided all of the equipment and functionality per Attachments 4.0 and 4.1, 9-1-1 CPE System Acceptance and Authorization Checklists.

#### **1.10.6. Acceptance Testing For Software (Other Than Operating System Software)**

Acceptance testing is required for all Contractor-supplied software supplied under this Contract including all software initially installed, improved versions (new repurchases) of this software, software which has been altered (modified) by the Contractor to satisfy PSAP requirements, and all substitute software provided by the Contractor in lieu thereof, unless otherwise provided herein. The purpose of the acceptance test is to ensure that the software operates in substantial accord with the Manufacturer's technical specifications and meets the PSAPs performance specifications. The specific procedures for the accomplishment of such tests are as stated in Acceptance Testing Criteria.

Following certification by the Contractor that programming aids, program products and applications listed in the PO have been delivered ready for PSAP use, the PSAP shall test each such programming aid, program product or application, in accordance with the Acceptance Testing Criteria.

If the Contractor has written application programs, the PSAP will provide test data and the Contractor will provide a test master and all output formats for such programs. The PSAP will process input transactions against the master file and produce the updated old and new master files to ensure that all transactions were applied correctly. All outputs will be checked

for accuracy, format and quality, and the programs will be accepted when the PSAP confirms that the application programs meet the specifications to which they were written.

### **1.11. SYSTEM REPLACEMENT AND PARTICIPATION**

Following PSAP acceptance testing period, if during a 30 consecutive day period the system does not achieve the required level(s) of availability, the PSAP will notify the Contractor in writing.

If the Contractor fails to bring the system to the required average availability level during the succeeding 30 consecutive days after notification by the CA 9-1-1 Branch, the PSAP may require the Contractor to replace the equipment failing to meet the standard of performance. Replaced equipment must also meet acceptance testing following installation as set forth in Acceptance.

During the term of the Contract if three (3) or more purchased installations are cancelled or are replaced for failing to meet this continuing standard of performance, the CA 9-1-1 Branch, at their sole discretion, may remove the identified system or affected components of the system from this Contract. There will be no cost to Cal OES or PSAP by a Contractor if a component of their equipment is removed from the Contract to include increase of cost for any system or components that remain on the Contract. This does not abridge Cal OES's rights under GSPD 401IT (09/05/14) Section #25, Rights and Remedies of State for Default.

### **1.12. PROJECT MANAGEMENT**

For each installation of a 9-1-1 system, the Contractor shall assign a Project Manager with knowledge and experience in managing system installations of similar complexity at no additional cost to the PSAP or the CA 9-1-1 Branch. All installations shall use industry accepted project management methodology throughout the project.

The Project Manager shall be the single point of contact between the Contractor and the PSAP throughout the installation and acceptance process. The Project Manager will be responsible for coordinating with the PSAP all aspects of the installation including project scheduling, installation of equipment, training, problem resolution, acceptance testing, contractual and technical issues and answering all questions the PSAP may have.

The Contractor shall assign a Project Manager who is familiar with 9-1-1 networks and Internet Protocol (IP) networks, as well as the proposed system.

### **1.13. SCHEDULE/PROJECT PLAN**

The Contractor shall submit an implementation schedule. The schedule shall include delivery timeframe and complete transition timeframes. The project plan shall break out completion of key project milestones as agreed to between the Contractor and PSAP.

The project plan shall be a task-oriented Gantt chart detailing the system installation, clearly identifying all external dependencies outside of the Contractor's control for a system and expected timelines.

An example of items that may be considered key milestones would be the network connection dependencies for core services, installation of equipment, approval of testing plans, testing of equipment. This is a sample and is not all inclusive of potential milestones.

## **1.14. MAINTENANCE**

### **1.14.1. General**

Equipment and Software shall be maintained in good operating condition to ensure the Continuing Standards of Performance prescribed criteria of Acceptance Testing of this Contract are met. The Contractor is responsible to maintain the equipment purchased under this Contract in good operating condition and shall always be responsive to the maintenance requirements of the PSAP. All such maintenance service, including parts, software support and labor, shall be furnished after the warranty period for up to four (4) years after the warranty period. Maintenance includes Software Support.

### **1.14.2. Maintenance Coverage**

The Contractor shall provide maintenance (labor and parts) and keep the equipment in good operating condition. Maintenance parts will be furnished by the Contractor and will be new or equivalent to new in performance when used for this equipment. Contractor is responsible for disposal of replaced parts removed during maintenance.

Contractor shall provide full maintenance coverage 24 hours per day, seven (7) days per week, 365 days a year (24x7x365).

### **1.14.3. Upgrades and Planned Maintenance Down-Time**

The proposed 9-1-1 CPE Systems shall not be adversely impacted by downtime planned maintenance. It is acceptable that individual components or elements have downtime for planned maintenance.

### **1.14.4. Planned Maintenance**

Planned maintenance shall be performed in accordance with a Standard Operating Procedure (SOP) mutually agreed to by the State and Contractor designed to mitigate the operational impact of such maintenance. Scheduled downtime must be coordinated with Cal OES/CA 9-1-1 Branch and affected PSAPs with at least five (5) business days advance notice prior to performing the scheduled downtime in order for the downtime not to be calculated into the monthly availability.

Contractor's shall disclose any service impact, limitation or operational issue that may arise as a consequence of planned maintenance and shall propose mitigation for the known impact, limitations or operational issues as part of the SOP.

### **1.14.5. Software Support**

Contractor shall provide software support for equipment acquired under this Contract. Software includes the operating parameters required by the PSAP for the applicable control

unit. This includes newly acquired control equipment as well as changes to existing equipment acquired under this Contract.

Software support must be available through term of Contract. The Contractor's software support must include a telephone number for both voice and facsimile communication that is free to any Telecommunicator within the PSAP.

Contractor shall apply necessary modifications to the CDR XML to meet the CA 9-1-1 Branch standard. Contractor shall defer questions and clarifications to the CA 9-1-1 Branch CPE Contract Manager for the most current requirements. Within six (6) months of notification of change in the CDR XML standard, the Contractor shall provide the enhancements and a sample of the data string that is produced by the CPE, along with a detailed description, that demonstrates how all of the data elements will be presented. Upon completion of the required CDR XML enhancements, all equipment installed under this Contract shall receive a software update to comply with the revised standard.

#### **1.14.6. Remedial Maintenance**

Contractors shall track the status of each Major and Minor Failure through the Trouble Ticket Log described in Section 1.19.2. Contractors shall provide the telephone number of their customer support center to each PSAP with whom they have a maintenance contract for reporting Major and Minor Failures. The Contractor's customer support center telephone shall be answered 24 hours a day, seven (7) days a week by a live person. The Contractor's customer support center will be responsible for coordinating the resources necessary to correct Major and Minor Failures and for accurately updating the Trouble Ticket Log.

The 9-1-1 CPE System shall be capable of alerting PSAP personnel of system alarms by the use of a signaling device in the PSAP. This device shall provide for an audible or visual alarm. The device shall provide a cutoff option to disable alarms in progress and must be automatically reset upon removal of the alarm condition or should a new alarm occur.

#### **1.14.7 Remote Maintenance**

The Contractor shall provide maintenance as described herein:

- 1) Full diagnostic access to all major components of the 9-1-1 CPE System;
- 2) Capability to disable or enable system ports to bypass failed ports;
- 3) A list of the most frequently failed components and the success rate of remote reports for these components;
- 4) Capability to access accumulated statistics on 9-1-1 CPE System performance such as error messages, power failures, etc.;
- 5) Description of the ability and types of software that can be remotely updated/replaced; and
- 6) Confirmation that access to the system will be password protected.

### **1.14.8 Telephone Line Repairs**

If the PSAPs notifies the Contractor of a problem with the 9-1-1 system and the Contractor determines that the problem lies with the telephone company service provider, the Contractor, will be responsible for notifying the PSAPs that the problem lies with the local telephone line service provider.

### **1.14.9 Warranty**

- 1) Notwithstanding GSPD 401IT (09/05/14) Section #18, Warranty, the Contractor warrants that all equipment provided under the authority of this Contract, when installed, will be in good working order, will be fit for the manufacturer's intended purpose and will conform to the Contractor's official published specifications.
- 2) Except as provided elsewhere in this Contract, the Contractor's obligations and liabilities with respect to this specific warranty provision are limited to the repair or replacement of any parts, software or equipment when either Cal OES or the Contractor determines that the equipment does not conform to the warranties stated herein.
- 3) The Contractor shall warrant the equipment and software to perform per the manufacturer's specifications for a period of one (1) year after acceptance. The Contractor shall furnish all warranty services and parts for a period of one (1) year beginning on the first day following System Acceptance at no cost to Cal OES, provided that such maintenance service or parts are not required because of accident, neglect, misuse, failure of electrical power or air conditioning, humidity control or causes other than ordinary use. Any such service required as a result of erroneous site preparation specifications furnished by the Contractor or otherwise required due to the fault or negligence of the Contractor, shall be provided by the Contractor at no additional charge. All replaced parts shall be property of the Contractor. Prior to the expiration of the warranty period, whenever equipment is shipped for mechanical replacement purposes, the Contractor shall bear all costs for such shipment including, but not limited to, costs of packing, transportation, rigging, drayage and insurance.
- 4) Service pursuant to this warranty will be furnished by the Contractor's nearest service location. The Contractor shall have prompt access to the equipment, subject to the PSAP's standard security requirements, to perform this service. There shall be no charge to travel expense associated with services for which the Contractor is responsible under this warranty provision.
- 5) When non-Contractor software is used by the PSAP and as a result the Contractor's maintenance diagnostic routines do not pinpoint the failure, the PSAP shall pay for the time spent by the Contractor in diagnosing the failure at the applicable per-call rate per man-hour then in effect.

- 6) When the Contractor is called to perform remedial maintenance service on the equipment and by mutual agreement it is determined that either no failure existed or that the service was outside the scope of this warranty, the PSAP shall pay for the travel expense in accordance with the State's then current short-term travel expense policy as stated in the State Administrative Manual Chapter 0700 (<http://sam.dgs.ca.gov/TOC/700.aspx>) and the time spent by the Contractor at the applicable time and materials rates then in effect.
- 7) Unless otherwise mutually agreed upon, the Contractor shall not be required to adjust or repair any equipment or part thereof if it would be impractical for the Contractor personnel to do so because of alterations made to the equipment or part thereof by or on behalf of the PSAP. The Contractor shall be responsible for interfaces with plug compatible equipment that is attached to the current controllers. Increased service pursuant to this warranty caused by any alteration or attachment shall be paid for by the PSAP at the applicable time and materials rates as stated in Exhibit 16, Cost Workbook, unless the Contractor elects not to apply such charge on an individual occurrence basis.

#### **1.14.10. Equipment Replacement**

When 9-1-1 CPE System equipment fails to function in the manner for which it was designed to the extent that the PSAPs ability to answer 9-1-1 emergency calls is adversely affected, the Contractor will make every attempt to satisfactorily resolve the problem.

After the PSAP's initial purchase from a Contractor, all commonly available components may be replaced at the risk and discretion of the PSAP. With the written consent of the Contractor, the PSAP may replace commonly available components that meet or exceed the manufacturer's specification. If certification or testing is required, the Contractor shall provide a price to the PSAP before proceeding with such certification process or testing. Such replacements of Contractor's equipment will be at the PSAP's expense, and shall be allowed by the Contractor if, in the Contractor's opinion, no safety hazard or system degradation of Contractor's remaining equipment or software is caused by such replacements. Maintenance agreements for replaced items may be separate from the maintenance for all Contractor provided equipment. Disputes regarding the use of commonly available components shall be resolved in accordance with GSPD 401 IT.

#### **1.14.11. Replacement Parts**

Contractor shall maintain an inventory of critical spare components and parts necessary to keep the 9-1-1 CPE systems running properly for all PSAPs to which the Contractor is responsible for providing support under this Contract. The spare components and parts shall be maintained in storage facilities that are located close enough to meet the Time to Repair objectives of the Service Level Objectives for Major and Minor Failures.

The spare components and parts inventory shall include, at a Minimum, power supplies, system boards, hard drives, Uninterruptable Power Supply (UPS) devices, computer monitors, computer keyboards, computer fans, and similar equipment. All replacement components and parts shall be available to authorized Contractor repair personnel on a 24x7x365.

#### **1.14.12. Technology Refresh**

Cal OES expects to allow for Technology Refresh as long as it is an evolution of existing technologies on the Contract. What the Contract offers, will be considered to be added as an amendment to the Contract at the State's sole discretion.

Contractor(s) are required to:

- 1) Support this effort throughout the life of the resulting Contract.
- 2) Proactively report to Cal OES Contract Manager at least every six (6) months, or as needed, based on changes in technology and make recommendations for changes in technology offerings.
- 3) Technology offered during technology refresh shall meet all current National Emergency Number Association (NENA) i3 requirements.
- 4) At the time of refresh notification, Contractor(s) shall provide to Cal OES Contract Manager the following:
  - a) A side by side comparison of the proposed new technology to the existing technology being replaced and its corresponding common configuration.
  - b) An up to date Road Map of the technology proposed to refresh the services.
  - c) An updated Cost Worksheet containing the items offered.

#### **1.15. MAINTENANCE SERVICE EXCLUSIONS**

Maintenance service does not include:

- 1) Electrical work external to equipment or maintenance of accessories, alterations, attachments or other devices not listed in Cost Workbook;
- 2) Repair of damage or increase in service time caused by accident or disaster, which shall include, but not be limited to, fire, flood, water, wind and lightning; transportation; neglect or misuse; alterations which include, but are not limited to, any deviation from Contractor's physical, mechanical or electrical equipment design; attachments, which are defined as the mechanical, electrical or electronic interconnection to Contractor equipment or non-Contractor equipment and devices not supplied by Contractor;

- 3) Repair of damage or increase in service time resulting from failure to provide a suitable installation environment with all facilities prescribed by the appropriate Contractor Installation Manual; Physical Planning (including, but not limited to, failure of, or failure to provide adequate electrical power, air-conditioning or humidity control);
- 4) Repair of damage or increase in service time attributable to the use of the equipment for other than data processing purposes for which acquired;
- 5) Furnishing supplies or accessories; painting or refinishing material; inspecting equipment altered by other than Contractor, making specification changes or performing services connected with relocation of equipment; or adding or removing accessories, attachments or other devices;
- 6) Such service which is impractical for Contractor to render because of alterations in the equipment or their connection by mechanical or electrical means to other equipment;

Repair of damage or increase in service time caused by the conversion from one Contractor model to another or the installation or removal of a Contractor feature whenever any of the foregoing was performed by other than Contractor.

**1.16. TECHNICAL SLA CHARTS – CPE TURN-KEY AND HOST REMOTE SYSTEMS**

The following technical Service Level Agreements (SLAs) provide charts describing the definition, measurement method, objective, and rights and remedies for each category.

All SLA's are self-reporting and it is the incumbent on the Contractor to report all outages that do not meet the objectives and the associated Rights and Remedies. SLA's are not intended to be punitive, but protect the State and/or PSAP and mitigate extended outages.

**1.16.1 System Readiness: Hardware and Software**

Definition	Measurement	Objective	Rights and Remedies
System readiness includes new installations, relocations, MACs ready for acceptance testing by the PSAP on or before the agreed to scheduled system readiness date.	System readiness dates are mutually agreed to by the PSAP and the Contractor in the SOW provided with each PO.	Certificate of system readiness submitted by the Contractor on or before the due date cited in the PO.	<p><b>Immediate Rights and Remedies:</b></p> 50% of the implementation charge when implementation charges are broken out or 10% of total bundled charges (excluding sales tax) when implementation charges are bundled with equipment, training, and/or additional services
			<p><b>Monthly Rights and Remedies:</b> If 95% of monthly implementation dates are not met:</p> Remaining 50% of implementation charge, when implementation charges are broken out or An additional 10% of total bundled charges (excluding sales tax) when implementation charges are bundled with equipment, training, and/or additional services

**1.16.2. Time to Repair Critical Failure**

Definition	Measurement	Objective	Rights and Remedies
<p>Following Acceptance, the time to repair a Critical Failure begins when the Contractor's customer support center is notified of the failure either through notification by the PSAP or by an alarm, whichever comes first, and ends when the PSAP representative confirms that the failure has been resolved.</p> <p>A Critical Failure is defined as any hardware or software failure that prevents the 9-1-1 PSAP location from making communication contact or viewing ANI or ALI information for a person who has contacted the PSAP on a 9-1-1 trunk/or equivalent ingress.</p>	<p>Time to repair will be measured through data in the Contractor's Trouble Ticket Log and will include the time from initial notification to the time that the PSAP has confirmed failure resolution.</p>	<p>Each Critical Failure will be resolved within four (4) hours of notification to the Contractor's customer support center or by alarm, whichever comes first.</p>	<p><b>Immediate Rights and Remedies:</b></p> <p>Each occurrence of a failure to meet this SLA objective shall result in a 25% rebate of the recurring monthly system maintenance fee or the projected monthly system maintenance fee during the warranty period of the affected PSAP.</p> <p>Excessive outage (more than 12 hours from the notification of the failure to PSAP confirmation of failure resolution) shall result in a rebate of 100% of the recurring monthly system maintenance fee or the projected monthly system maintenance fee during the warranty period of the affected PSAP.</p>

**1.16.3. Time to Repair Major Failure**

Definition	Measurement	Objective	Rights and Remedies
<p>Following Acceptance, the time to repair a Major Failure begins when the Contractor's customer support center is notified of the failure either through notification by the PSAP or by an alarm, whichever comes first, and ends when the PSAP representative confirms that the failure has been resolved.</p> <p>A Major Failure is a loss of 25% or more of any or all of the following:                      Call-carrying capacity of the system, trunks, or Telecommunicator answering IWSSs.</p>	<p>Time to repair will be measured through data in the Contractor's Trouble Ticket Log and will include the time from initial notification to the time that the PSAP has confirmed failure resolution.</p>	<p>Each Major Failure will be resolved within eight (8) hours of notification to the Contractor's customer support center or by alarm, whichever comes first.</p>	<p><b>Immediate Rights and Remedies:</b></p> <p>Each occurrence of a failure to meet this SLA objective shall result in a 15% rebate of the recurring monthly system maintenance fee or the projected monthly system maintenance fee during the warranty period of the affected PSAP.</p> <p>Excessive outage (more than 12 hours from the notification of the failure to PSAP confirmation of failure resolution) shall result in a rebate of 100% of the recurring monthly system maintenance fee or the projected monthly system maintenance fee during the warranty period of the affected PSAP.</p>

**1.16.4. Time to Repair Minor Failure**

Definition	Measurement	Objective	Rights and Remedies
<p>Following Acceptance, the time to repair a Minor Failure begins when the Contractor's customer support center is notified of the failure either through notification by the PSAP or by an alarm, whichever comes first, and ends when the PSAP representative confirms that the failure has been resolved.</p> <p>A Minor Failure is defined as any hardware or software failure that prevents any feature of the 9-1-1 CPE System provided by the contractor from meeting the specifications of the business, functional and technical requirements.</p>	<p>Time to repair will be measured through data in the Contractor's Trouble Ticket Log and will include the time from initial notification the time that the PSAP has confirmed failure resolution.</p>	<p>Each Minor Failure will be resolved within 48 hours of notification to the Contractor's customer support center or by alarm, whichever comes first.</p>	<p><b>Immediate Rights and Remedies:</b></p> <p>Each occurrence of a failure to meet the SLA objective shall result in a 10% rebate of the recurring monthly system maintenance fee or the projected monthly system maintenance fee during the warranty period of the affected PSAP.</p> <p>Excessive outage (more than 240 hours from the notification of the failure) to PSAP confirmation of failure resolution) shall result in a rebate of 50% of the recurring monthly system maintenance fee or the projected monthly system maintenance fee during the warranty period of the affected PSAP.</p>

**1.16.5. Availability**

Definition	Measurement	Objective	Rights and Remedies
<p>Following Acceptance, service availability includes the scheduled uptime for all system components and functionality for each item Required in the System Acceptance and Authorization Checklist.</p> <p>Availability is to capture multiple short duration outages within a month that do not trigger other time to repair SLA's such as Critical, Major, and Minor.</p>	<p>Monthly uptime percentage is calculated by dividing the total uptime hours by the total hours available in the month for each component or functionality. Stop-clock provisions apply.</p>	<p>Monthly up-time shall be greater than 99.9%.</p>	<p><b>Monthly Rights and Remedies:</b></p> <p>20% of the recurring monthly system maintenance fee or the projected monthly system maintenance fee of the affective PSAP if the monthly objective is not met. Each successive month that the monthly objective is not met will result in an increase in the remedy of an additional 20% over the previous month, not to exceed 60%.</p> <p>Additionally, if the Contractor fails to achieve the up-time objective three (3) months in a row or five (5) months in any 12 month period, the PSAP may terminate the maintenance agreement with 30 calendar days' notice and engage the services of an alternative Contractor with no early termination charges to the State or the PSAP.</p>

### 1.17. STOP CLOCK CONDITIONS (M)

The following Stop-Clock Conditions shall apply during the term of this Contract including any and all extensions. Timeframes are dependent on the length of time the Contractor takes to restore the service, minus the time associated with events outside of the Contractor's control to prevent punitive damages from being assessed.

- 1) Periods when a restoration or testing effort is delayed at the specific request of the PSAPs. The Stop-Clock condition shall exist during the period the Contractor was delayed, provided that reasonable and documented efforts are made to contact the PSAPs during the applicable Stop-Clock period;
- 2) Time after a service has been restored, but the PSAPs requests ticket be kept open for observation. If the service is later determined by the PSAPs to not have been restored, the Stop-Clock shall continue until the time the PSAPs notifies the Contractor that the service has not been restored;
- 3) Time after a service has been restored, but the PSAPs is not available to verify that the service is working. If the service is later determined by the PSAPs to not have been restored, the Stop-Clock shall apply only for the time period between Contractor's reasonable attempt to notify the PSAPs that Contractor believes the service has been restored and the time the PSAPs notifies the Contractor that the service has not been restored;
- 4) Restoration cannot be achieved because the problem has been isolated to wiring that is not maintained by Contractor, or any of its subsidiaries, subcontractors, or affiliates;
- 5) Trouble caused by a power problem outside of the responsibility of the Contractor after the initial 15 minutes;
- 6) Lack of building entrance facilities or conduit structure that are the PSAPs responsibility to provide;
- 7) PSAPs failure to prepare the site in accordance with the Contractor's site readiness requirements;
- 8) The following contact/access problems, provided that Contractor makes reasonable efforts to contact the PSAPs during the applicable stop-clock period:
  - a) Access necessary to correct the problem is not available because access has not been arranged by site contact or the PSAPs representative;
  - b) Site contact refuses access to technician who displays proper identification;

- c) Insufficient or incorrect site contact information which prevents access, provided that Contractor takes reasonable steps to notify the PSAPs of the improper contact information and takes reasonable steps to obtain the correct information;
  - d) Site has limited hours of business that directly impacts the Contractor's ability to resolve the problem;
  - e) If it is determined later that the cause of the problem was not at the site in question, then the Stop-Clock shall not apply;
  - f) Any problem or delay to the extent caused by PSAPs staff that prevents or delays Contractor's resolution of the problem. In such event, Contractor shall make a reasonable request to PSAPs staff to correct the problem or delay;
  - g) PSAPs applications that interfere with repair of the trouble.
  - h) Failure of the Trouble Ticket originator or responsible party to return a call from Contractor's technician for on-line close-out of Trouble Tickets after the service has been restored as long as Contractor can provide documentation substantiating message from Contractor's technician.
- 9) An outage directly related to any properly performed scheduled maintenance or upgrade. Any such Stop-Clock condition shall not extend beyond the scheduled period of the maintenance or upgrade. SLAs will apply for any maintenance caused outage beyond the scheduled maintenance period. Outages occurring during a scheduled maintenance or upgrade period and not caused by the scheduled maintenance shall not be considered a Stop-Clock condition;
- 10) Any problem or delay caused by a third party not under the control of Contractor, not reasonably preventable by Contractor, including cable cuts not caused by the Contractor. Contractor's affiliates, subsidiaries or subcontractors shall be deemed to be under the control of Contractor with respect to the equipment, services or facilities to be provided under this Contract;
- 11) Force Majeure events, as defined in GSPD 401IT, Section 24;
- 12) If equipment failure is caused by alterations or attachments not furnished, approved or maintained by the Contractor.

## **1.18. REPORTING REQUIREMENTS**

### **1.18.1 Monthly SLA Compliance Report**

The Monthly SLA Compliance Report shall be provided in the format shown in 2.0, Contractor's Monthly SLA Compliance Report. Contractors shall submit a monthly report to the CA 9-1-1 Branch no more than 30 calendar days following the end of the reporting month that reflects the status of all SLA objectives that were not met during the previous month, including the rights and remedies.

The report shall list all Trouble Tickets that were open and/or acted upon during the reported month, including tickets not qualifying for SLA remedy. This report shall show what SLA rights and remedies were applied to each ticket number, when applicable. If no Trouble Tickets were opened and/or acted upon during a month, the report shall state there were no issues or tickets for that month.

The monthly SLA compliance report shall include the following detail:

- 1) Report period,
- 2) Contractor's trouble ticket number,
- 3) PSAP name,
- 4) PSAP FCC ID,
- 5) Service type,
- 6) Brief trouble symptom,
- 7) Brief restoration description,
- 8) Ticket open date and time,
- 9) Problem resolution date and time,
- 10) Total stop clock duration, outage duration,
- 11) Yes/No if qualified for SLA,
- 12) The applicable SLA, and
- 13) Rights and remedies applied to each ticket when applicable

Definition	Measurement	Objective	Rights and Remedies
<p>Reporting Requirement</p> <p>Contractors shall provide the reports required by this CONTRACT for each month of activity during the term of the contract.</p>	<p>Calendar Days.</p>	<p>Contractors shall deliver accurate and complete reports no more than 30 calendar days following the end of the applicable reporting month.</p>	<p>Each occurrence of a failure to meet the objective shall result in a \$50.00 rebate for each business day that the report is not delivered after the objective.</p>
<p>SLA Remedy Delivery</p> <p>Timely payment of remedies due to Cal OES/CA 9-1-1 Branch for missed SLA objectives.</p>	<p>Calendar Days</p>	<p>Contractor’s check shall be issued no more than 60 calendar days following the end of the month in which the SLA remedies applied.</p>	<p>Each occurrence of an SLA remedy (check) that is not issued within 60 calendar days following the end of the month in which the remedy applied will result in an additional \$50.00 payment for each business day that the check is not issued.</p>

**1.18.2. Trouble Ticket Log**

Contractors shall maintain a Trouble Ticket Log that will track the progress and status of restoration for all SLAs. The Contractor’s Trouble Ticket Log will include the date and time that each Failure was reported, or system alarm of failure whichever occurs first, each PSAP affected by the failure, the current status of the restoration process and the date and time that the failure is remedied to the PSAP representative’s satisfaction. The Contractor shall provide remote, seven (7) day, 24 hour access to the CA 9-1-1 Branch in order to track progress of the restoration of failures and to validate SLA calculations.

**1.18.3. Contractor’s Monthly Activity Report**

Each month, Contractors shall provide the CA 9-1-1 Branch with a detailed report of the status of transactions made under this Contract using Attachment 1.0, Contractor’s Monthly Activity Report. Cal OES reserves the right to require the Contractor to modify the format and content of these reports no more than two (2) times during the Contract term at no cost.

The Contractor’s Monthly Activity Report shall include the fields listed below and shall be provided in the format shown below;

- 1) PSAPs Name – Name of the PSAPs that has been funded for the transaction;

- 2) CA 9-1-1 Branch Tracking Number – The Tracking Number provided by the CA 9-1-1 Branch for the transaction;
- 3) Status of the Installation – Reflects the status of the order at the end of the reporting period and shall include one (1) of the following status descriptions: Order Received, Delivered, Installed, Certificate of Readiness delivered, Acceptance Testing in progress, Accepted Awaiting Payment or Payment Received;
- 4) Scheduled Acceptance Start Date – The Acceptance Start Date as reflected on the SOW that has been approved by the CA 9-1-1 Branch;
- 5) Actual Acceptance Date – The date that the System Acceptance and Authorization Checklist is signed by an authorized representative of the PSAPs;
- 6) Order Value – The dollar amount of the SOW as approved by the CA 9-1-1 Branch.

#### **1.19. 9-1-1 CPE SYSTEM DELIVERABLES**

The Contractor shall:

- 1) Provide the 9-1-1 CPE System Equipment;
- 2) Work with PSAP/s in following the User Instructions for ordering;
- 3) Deliver and provide all documents in electronic format unless a hardcopy is specifically requested by Cal OES/CA 9-1-1 Branch;
- 4) Report all SLAs in accordance with Section 1.19, Reporting Requirements;
- 5) Deliver all equipment necessary for the 9-1-1 CPE Stand-Alone Configuration or the Host-Remote System;
- 6) Deliver the system ready-for-use within 180 calendar days ARO as indicated on the PO and defined in Section 1.9, Installation Date.
- 7) Perform and provide a site survey per Section 1.9.2, Site Survey;
- 8) Provide documentation consisting of copies of all non-proprietary manuals and other printed materials, including updated versions, which are useful and necessary to the PSAP in its use of the equipment or software provided at prices listed in Exhibit 16, Cost Workbook and referenced in Section 1.9.7, Documentation.
- 9) Provide transportation for shipments to and from the installation site per Section 1.10.1, Transportation;

- 10) Perform the packing, unpacking and placement of equipment as defined in Section 1.10.2;
- 11) Deliver a police or fire report that relieves the PSAP of all risk due to loss or damage of equipment purchased under this Contract during periods of transportation, installation and during the entire time the equipment is in the possession of the Contractor. PSAP assumes responsibility for loss or damage to equipment after Formal Acceptance as detailed in Section 1.10.3, Risk of Loss or Damage;
- 12) Make deliveries during the PSAP's delivery hours per Section 1.9.1, Restricted Delivery Hours;
- 13) Be responsible to provide the following required IWS wiring:
  - a) Install dedicated port jacks near the PSAP-owned Computer Aided Dispatch (CAD), logging recorder and third-party mapping equipment.
  - b) Provide console jacks and cabling. The wiring runs that are to be provided must be terminated to patch panels in the telephone room of each PSAP. A total of six (6) jacks must be terminated at each 9-1-1 IWS. Four (4) of the six (6) jacks will be wired to the Telecommunications Industry Association (TIA) / Electronic Industry Association (EIA) 568B standard. The remaining two (2) cables must be connected to RJ-11 jacks.
  - c) Ensure jacks are labeled clearly at each branch location; and the jack number must match the IWS number where it is located. For example: IWS one (1) must have jack number one (1) installed. The jacks themselves must be labeled A through F and correspond with the patch panel located in the equipment room or wiring closet. All termination blocks shall have a cover and labeled "9-1-1 ONLY".
  - d) Reserve the jack that is labeled as "F", the RJ-11, for voice logger applications and will be terminated on a telephony style block. The jack that is labeled "E" is the RJ-11 that is reserved for telephony applications that will be required.
  - e) Install advanced cabling for Universal Serial Bus (USB) or High-Definition Multi-Media Interface (HDMI) will need to be specified by the PSAP if interfacing to associated equipment is special.
  - f) Have a surplus structured wiring available at each IWS for potential future applications.
- 14) Write a certificate of system readiness when the service is ready for acceptance testing per Sections 1.9.3, Certification of Facility Readiness, and 1.9.4, Certification of Equipment Readiness;

- 15) Perform System Acceptance Testing to ensure that the system operates in substantial accord with the technical specifications, is adequate to perform as warranted by Contractor's response to the requirements of this Contract and evidences a satisfactory level of performance reliability, prior to its acceptance as defined in Sections 1.11.2, System Acceptance Testing and 1.11.3, Acceptance Testing for Software (Other than Operating System Software);
- 16) Develop and submit an implementation schedule/project plan per Section 1.14, Schedule/Project Plan; and
- 17) Perform maintenance service including parts, software support and labor per Section 1.15 Maintenance.

## **1.20. ACCEPTANCE OF DELIVERABLES**

It shall be in Cal OES's sole determination as to whether a deliverable has been successfully completed and acceptable to Cal OES. Acceptance criteria shall consist of the following:

- 1) It shall be Cal OES's sole determination as to whether the tasks and deliverables identified in this Agreement have been successfully completed and are acceptable.
- 2) The Contractor costs related to rework of unacceptable work products shall be costs of the Contractor, and shall not be billed to Cal OES.
- 3) The Contractor shall meet all time-lines and deliverable dates, as agreed to in the Agreement

## **1.21. TRAINING**

### **1.21.1. Training Times and Locations**

For the purposes of training, the Contractor shall provide formal, hands-on instruction for PSAP personnel in operation of the equipment, at mutually agreeable times prior to or, with PSAP approval, during the acceptance testing period. Training for Equipment Installation Coordinators and Project Leaders will be conducted at the PSAP site unless an alternate site is mutually agreed to by the PSAP and the Contractor.

### **1.21.2. Training Plan**

No more than 30 calendar days following Contract award, Contractors shall provide to the PSAP a detailed training plan describing their concept of the scope of training, the duration of initial training (in hours per student), and the training aids (including operating manuals) which are required to train Programmers, Telecommunicators, Support Staff and User Training Specialists in the operation of all hardware and software.

The Contractor shall provide training and training materials to ensure that Telecommunicators and System Administrators can proficiently use the 9-1-1 CPE system. The Contractor will provide the following at no additional cost to the PSAP or the CA 9-1-1 Branch:

- 1) A comprehensive training program that provides the Telecommunicators with the skills necessary to operate all the features of the 9-1-1 system;
- 2) Training at a time mutually agreed upon by the PSAP and the Contractor;
- 3) Instructors who have the technical skills, teaching skills and abilities necessary to instruct others how to use the equipment proficiently;
- 4) Train no more than six (6) Telecommunicators per instructor, per class, unless a larger class is mutually agreed to by the PSAP and the Contractor. All training classes should be scheduled so as to reduce the number of site visits necessary to train all personnel;
- 5) Provide at least two (2) fully operational IWSs with at least one (1) operational phone line for training purposes. Fully operational means features and user defined parameters are fully functional so all features can be realistically demonstrated during training. The two (2) IWSs used for training will also be used to complete the installation of all ordered IWSs. Training IWSs may be temporarily installed in a training room at the installation facility. Temporary cabling to a training room will be provided upon request of the PSAP. Cost to cable temporary IWSs shall be at the hourly rate provided for MACs;
- 6) Contractor will compile a list of Telecommunicators who attended training, the date and time of the training and rate the proficiency of the Telecommunicators to use the equipment on a pass or fail basis. A copy of this information will be provided to the PSAP Manager;
- 7) In addition to the Telecommunicator training, the Contractor will provide Supervisor/System Administrator training, with no more than six (6) Supervisors/System Administrators per class. This training shall cover routine MACs accessible by a System Administrator, routine trouble shooting procedures and problem reporting procedures. Training for statistics report generation shall be provided no more than 30 calendar days following cutover. Training will also include an on-site instructor(s) for a period not to exceed 24 hours upon beginning of the system acceptance testing period. The purpose of the instructor(s) will be to assist PSAP personnel as needed after they begin using the new equipment. The instructor(s) can be on-site for the first 24 hour period of system acceptance testing or up to two (2) periods totaling not more than 24 hours during the first seven (7) calendar days of the system acceptance testing period;
- 8) Post-cutover training may be provided at an additional cost to the PSAP at the rate established by this Contract. Post-cutover training will be provided for no less than six (6) Telecommunicators or system administrators; and
- 9) Appropriate manuals and other materials must be provided to each participant in training. Training materials shall become the property of the PSAP upon completion of the training. Manuals of sufficient detail to successfully operate both the software system and the hardware system must be provided. Contractor shall document in the SOW the operation

of all customer specified programming not specifically covered by the manufacturer user manuals.

### **1.21.3. Training on New or Substitute Equipment**

If requested by the PSAP, training and documentation on new or substitute equipment shall be provided by the Contractor at no charge to the PSAP or the CA 9-1-1 Branch. The training shall provide an overview of the new or substitute equipment capabilities and operational procedures. This additional training shall be provided by the Contractor at no additional charge in instances where equipment is upgraded and/or changed during the lifetime of the contract, provided that the equipment change includes a change in equipment operation. The CA 9-1-1 Branch reserves the right to make final determination in cases of disagreements that may arise under this section.

### **1.22. ALTERATIONS AND ATTACHMENTS**

- 1) With the written consent of the Contractor, while still enforcing the SLA's, such consent not to be unreasonably withheld, the PSAPs may make alterations or install attachments to the equipment at the PSAP's expense if, in the Contractor's opinion, no safety hazard is thereby created. The PSAPs shall assume full liability for any damages and/or degradation of equipment performance attributable to such alteration or attachment. For example, firewall or workstation hardware.
- 2) If the alteration or attachment interferes with the normal and satisfactory maintenance of any of the equipment in such a manner as to render maintenance impractical, the PSAPs will, upon notice from the Contractor to that effect, remove the alteration or attachment and restore the equipment to its normal condition within 10 working days.
- 3) If an inspection by the Contractor is required to determine if the equipment or system remains practical to maintain or that no safety hazard has been created, the PSAPs shall be so notified and a mutually agreeable inspection date will be scheduled. Charges for such inspection shall be paid by the PSAPs, at the applicable rates from Exhibit 16 Cost Workbook, Tab 5, Labor Rates.
- 4) Repair of damage or increase in the Contractor's service personnel time attributable to the alteration or attachment will be billed to the PSAPs at the Contractor's rate provided in Exhibit 16 Cost Workbook, Tab 5, Labor Rates.
- 5) All reprogramming agreed to by the Contractor that is required to accommodate such alterations and/or attachments shall be implemented at the PSAPs expense.

### **1.23. PSAP RESPONSIBILITIES**

- 1) The PSAP is responsible for the arrangements for provisioning of all telephone lines required for the Contractor's system, including a line for remote maintenance.
- 2) The PSAPs will provide adequate storage space for spare parts, and adequate working space, including heat, light, ventilation, electrical current and outlets, for the use of the Contractor's maintenance personnel at the time maintenance is being performed. These facilities shall be within a reasonable distance of the equipment to be serviced and shall be provided at no charge to the Contractor.
- 3) If required to meet special environmental considerations, the PSAP will modify its site facilities to meet the Contractor's minimum site and environmental specifications as supplied by the Contractor. These specifications shall be in such detail as to ensure that equipment, if installed according to these specifications, shall operate efficiently from an environmental point of view and properly from a functional point of view. These modifications shall be in line with the floor plan of the Communications Operations Room.
- 4) Subject to the PSAPs security regulations, the Contractor shall have full and free access to the equipment to provide service thereon. If persons other than Contractor representatives have performed maintenance or repair of equipment, and, as a result, further repair by Contractor is required, such further repairs will be made at Contractor's then applicable time and material rates, as shown in Exhibit 16, Cost Workbook.
- 5) The PSAP is responsible for providing DSL or other high speed internet connection.
- 6) The PSAPs shall maintain records and documentation associated with contractor.

### **1.24. STATE RESPONSIBILITIES**

Cal OES will designate a person to whom all Contractor communication may be addressed, and who has the authority to act on all aspects of the services. This person will review the SOW and associated documents with the Contractor to ensure understanding of the responsibilities of both parties. Cal OES designee shall:

- 1) Provide access to department staff and management, offices and operation areas, as required, to complete the tasks and activities defined under this Agreement.
- 2) Provide at least a minimum of 10 Cal OES business days for the timely review and approval of information and documentation provided by the Contractor to perform its obligations.

### 1.24.1. Performance

Cal OES will be the sole judge of the acceptability of all work performed and all work products produced by the Contractor as a result of this SOW. Should the work performed or the products produced by the Contractor fail to meet Cal OES conditions, requirements, specifications, guidelines, or other applicable standards, the following resolution process will be employed, except as superseded by other binding processes:

- 1) Cal OES will notify the Contractor in writing within five (5) State business days after completion of each phase of service of all acceptance problems by identifying the specific inadequacies and/or failures in the services performed and/or the products produced by the Contractor.
- 2) The Contractor will, within five (5) Cal OES business days after initial problem notification, respond to Cal OES by submitting a detailed explanation describing precisely how the identified services and/or products actually adhere to and satisfy all applicable requirements, and/or a proposed corrective action plan to address the specific inadequacies and/or failures in the identified services and/or products. Failure by the Contractor to respond to Cal OES's initial problem notification within the required time limits may result in immediate termination of the Contract.

In the event of such termination, Cal OES shall pay all amounts due the Contractor for all work accepted prior to termination.

- 3) Cal OES will, within five (5) Cal OES business days after receipt of the Contractor's detailed explanation and/or proposed corrective action plan, notify the Contractor in writing whether it accepts or rejects the explanation and/or plan. If Cal OES rejects the explanation and/or plan, the Contractor will submit a revised corrective action plan within three (3) State business days of notification of rejection. Failure by the Contractor to respond to Cal OES's notification of rejection by submitting a revised corrective action plan within the required time limits may result in immediate termination of the Contract. In the event of such termination, Cal OES shall pay all amounts due the Contractor for all work accepted prior to termination.
- 4) Cal OES will, within three (3) Cal OES business days of receipt of the revised corrective action plan, notify the Contractor in writing whether it accepts or rejects the revised corrective action plan proposed by the Contractor. Rejection of the revised corrective action plan will result in immediate termination of the Contract. In the event of such termination, Cal OES shall pay all amounts due the Contractor for all work accepted prior to termination.

### **1.25. PROBLEM ESCALATION**

The parties acknowledge and agree that certain technical and project related problems or issues may arise, and that such matters shall be brought to Cal OES's attention. Problems or issues shall normally be reported in regular status reports. There may be instances; however, where the severity of the problems justifies escalated reporting. To this extent, the Contractor will determine the level of severity and notify the appropriate State personnel. Cal OES personnel notified, and the time period taken to report the problem or issue, shall be at a level commensurate with the severity of the problem or issue. Cal OES personnel include, but are not limited to, the following:

First level: Alicia Fuller, Contract Manager, (916) 657-6119

Second level: Ryan Sunahara, Senior Telecommunications Engineer, (916) 657-9100

Third level: Budge Currier, 9-1-1 Branch Manager, (916) 657-9911

### **1.26. CANCELLATION**

Cal OES may exercise its option to terminate the Agreement at any time with 30 calendar days prior written notice. In the event of such termination, Cal OES shall pay all amounts due the Contractor for all deliverables accepted prior to termination.

### **1.27. SUBCONTRACTOR AGREEMENT**

- 1) The Contractor will act as Prime Contractor under this Agreement. In addition to identifying all personnel proposed to work under this Agreement, the Contractor shall also identify its subcontractor affiliation, as applicable.
- 2) Cal OES reserves the right to approve all subcontractors prior to the performance of work by the subcontractor.
- 3) Nothing contained in this Agreement shall create a contractual relationship between Cal OES and subcontractors, and no subcontract shall relieve the Contractor of its responsibilities and obligations hereunder. The Contractor is fully responsible to Cal OES for the acts and omissions of its subcontractors and of persons either directly or indirectly employed by them.
- 4) If a subcontractor is a California Certified Small Business and/or Disabled Veteran's Business Enterprise (DVBE), then those amounts paid to certified subcontractors shall be identified on the Contractor's invoice(s).
- 5) The Contractor's obligation to pay its subcontractors is an independent obligation from Cal OES's obligation to make payments to the Contractor. As a result, Cal OES shall have no obligation to pay or to enforce the payment of monies to a subcontractor.

**SOW ATTACHMENT 1.0: CONTRACTOR'S MONTHLY ACTIVITY REPORT**

*Contractor's Name:*  
*Contact Name:*  
*Contact Telephone Number:*  
*Contact e-mail address:*  
*Reporting Month/Year:*

PSAP Name	CA 9-1-1 Branch Tracking number	Status of Installation <sup>1</sup>	Scheduled Acceptance Start Date <sup>2</sup>	Actual Acceptance Date <sup>3</sup>	Order Value <sup>4</sup>	DVBE Participation	Notes

---

<sup>1</sup> Status of Installation shall reflect the status of the order at the end of the reporting period and shall include one of the following status descriptions: Order Received, Delivered, Installed, Certificate of Readiness delivered, and Acceptance Testing in progress, Accepted Awaiting Payment or Payment Received.  
<sup>2</sup> Mutually agreed upon date between Contractor and PSAP that the system acceptance period of two-hundred-forty (240) continuous hours can begin in accordance with Section 1.11.1.  
<sup>3</sup> Date that the 9-1-1 System Acceptance form is signed by the PSAP responsible party.  
<sup>4</sup> The dollar value of the transaction as approved by the CA 9-1-1 Branch.

**SOW ATTACHMENT 2.0: CONTRACTOR'S MONTHLY SERVICE LEVEL AGREEMENT (SLA)  
 COMPLIANCE REPORT TURN-KEY 9-1-1 CPE SYSTEM**

*Contractor's Name:*  
*Contact Name:*  
*Contact Telephone Number:*  
*Contact e-mail address:*  
*Reporting Month/Year:*

**Provisioning SLAs**

PSAP Name	CA 9-1-1 Branch Tracking number	Scheduled Acceptance Start Date	Actual Acceptance Date	Rights and Remedies

**Time to Repair and Availability SLAs**

PSAP Name	Trouble Ticket Number	Equipment Type	Type of Failure	Brief Restoration Description	Alarm/Ticket Open Date and Time	Problem Resolution Date and Time	Total Stop-Clock Duration	Outage Duration	Applicable SLA	Rights and Remedies

**Administrative SLAs**

Requirement	Scheduled Date	Due	Actual Date	Delivery	Applicable Remedy
Monthly Activity Report					
SLA Compliance Report					
SLA Remedy Delivery					

**SOW ATTACHMENT 2.1: CONTRACTOR'S MONTHLY SERVICE LEVEL AGREEMENT (SLA)  
 COMPLIANCE REPORT 9-1-1 CPE HOST-REMOTE SYSTEM**

*Contractor's Name:*  
*Contact Name:*  
*Contact Telephone Number:*  
*Contact e-mail address:*  
*Reporting Month/Year:*

**Provisioning SLAs**

PSAP Name	CA 9-1-1 Branch Tracking number	Scheduled Acceptance Start Date	Actual Acceptance Date	Rights and Remedies

**Time to Repair and Availability SLAs**

PSAP Name	Trouble Ticket Number	Equipment Type	Type of Failure	Brief Restoration Description	Alarm/Ticket Open Date and Time	Problem Resolution Date and Time	Total Stop-Clock Duration	Outage Duration	Applicable SLA	Rights and Remedies

**Administrative SLAs**

Requirement	Scheduled Date	Due	Actual Date	Delivery	Applicable Remedy
Monthly Activity Report					
SLA Compliance Report					
SLA Remedy Delivery					

### **SOW ATTACHMENT 3.0: CONTRACTOR'S SAMPLE STATEMENT OF WORK TURN-KEY 9-1-1 CPE SYSTEM FORMAT**

The sample SOW provided below is preferred by the CA 9-1-1 Branch. Based upon past experience, this format provides all of the required information in a format that is most expeditiously processed by the CA 9-1-1 Branch.

A. Cover Page (should include the following)

1. Contractor Name
2. PSAP Name
3. Project name (example Turn-key 9-1-1 CPE System for ABC City)

B. Table of Contents

1. Include all of the major categories and subcategories

C. Body

1. Overview

- a. An overall statement about the purpose of the SOW and scope of the project;
- b. A list of the equipment, software and maintenance to be provided (workstation, back room, MIS, etc.) including quantities, individual prices and extended prices;
- c. A description of the existing equipment that will be reused;
- d. A description of the equipment that is to be provided by the PSAP;
- e. Specific equipment that will not be provided by the Contractor to ensure that the PSAP and the State understand what has been specifically excluded from the project;
- f. Any other general issues.

2. Design

- a. System overview including a description of the network configuration and interfaces, ALL connections, gateways, UPS, logging recorders, interfaces to other equipment and any other pertinent system element;
- b. Description of the network elements to be connected to the system including 9-1-1 trunks, 10-digit emergency lines, administration lines, ring-down lines, remote maintenance lines and any other network connections that will be configured in the system;
- c. A description of the how the system programming will be initially accomplished and how it will be maintained on an ongoing basis;
- d. Integration Requirements to other equipment such as CAD, radio, and clock syncing equipment;

- e. Building modifications that the PSAP will have to make to accommodate the new or updated system.
3. Change Requests
  - a. A description of how changes to the SOW will be managed by the State and the Contractor including identifying the authorized representatives that can approve changes and the specific process that will be followed to approve changes.
4. Acceptance Testing
  - a. An Acceptance Test Plan with a clear description of the acceptance testing process that is consistent with the Contract Requirements including the System Acceptance and Authorization Checklist;
  - b. A description of how MACs are handled once Acceptance has been signed off by the authorized PSAP representative.
5. Names of Responsible Parties and Contact Information
  - a. Names and contact information of all the responsible parties from the Contractor, PSAP and the CA 9-1-1 Branch.
6. Responsibilities
  - a. Contractor's responsibilities;
  - b. Identified responsibilities of others;
  - c. CA 9-1-1 Branch responsibilities.
7. Revised PSAP Profile (with a copy to the CA 9-1-1 Branch MIS Statewide provider);
8. Installation Schedule
  - a. List of key dates beginning with the funding approval date from the CA 9-1-1 Branch;
  - b. Include equipment order date, delivery date, site readiness by PSAP date, programming freeze date, beginning of installation date, system in-service date, anticipated PSAP acceptance date and any other dates pertinent to the success of the project.
9. Warranty Provisions
  - a. Acknowledgement of the terms of the warranty provisions of the Contract.
10. Maintenance Plan
  - a. Remote maintenance processes;
  - b. Description of how preventive maintenance will be provided;
  - c. Description of how remedial maintenance will be provided, including response times for major and minor outages;

- d. Description of the Minimum level of technical expertise that the maintenance technicians will have;
- e. Contact numbers to report trouble and the hours of availability for the contact center;
- f. A description of what is not covered in the maintenance plan and how those situations will be handled by the Contractor.

#### 11. Training

- a. A Training Plan that includes the following:
- b. A description of the training that will be provided to the PSAP management staff, Telecommunicators and PSAP technical support personnel;
- c. Description of the user manuals that will be provided by the Contractor;
- d. Description of the technical service manuals that will be provided by the Contractor.

#### 12. SOW Approval

- a. A sign-off page for the authorized PSAP representative to acknowledge concurrence with the content of the SOW.

#### 13. Appendices

- a. Site Certification Document
- b. The document that describes the building and environmental changes that the PSAP must make to accommodate the new or updated system;
- c. Floor Plan
- d. Diagrams of the room where the workstations will be installed and the telephone facilities room at the PSAP;
- e. Pricing and Terms
- f. A copy of the detailed quote from the Contractor for the project that includes specific part numbers from the multiple award contract, quantities, and maintenance costs;
- g. Forms
- h. Samples of the forms that will be used for the project such as change request forms, issue communications forms and any other applicable forms;
- i. Systems Acceptance and Authorization Checklist

A copy of the System Acceptance and Authorization Checklist (SOW Attachment 4.0) to be completed and signed by the authorized PSAP representative upon acceptance. The executed form will be provided to the CA 9-1-1 Branch as documentation of system acceptance and beginning of the warranty period for the system.

**SOW ATTACHMENT 3.1: CONTRACTOR'S SAMPLE STATEMENT OF WORK  
9-1-1 CPE HOST-REMOTE SYSTEM FORMAT**

The sample SOW provided below is preferred by the CA 9-1-1 Branch. Based upon past experience, this format provides all of the required information in a format that is most expeditiously processed by the CA 9-1-1 Branch.

A. Cover Page (should include the following)

1. Contractor Name
2. PSAP Name
3. Project name (example 9-1-1 CPE Host-Remote System ABC County)

B. Table of Contents

1. Include all of the major categories and subcategories

C. Body

1. Overview

- a. An overall statement about the purpose of the SOW and scope of the project;
- b. A list of the equipment, software and maintenance to be provided (workstation, back room, MIS, etc.) including quantities, individual prices and extended prices;
- c. A description of the existing equipment that will be reused;
- d. A description of the equipment that is to be provided by the PSAP;
- e. Specific equipment that will not be provided by the Contractor to ensure that the PSAP and the State understand what has been specifically excluded from the project;
- f. Any other general issues.

2. Design

- a. System overview including a description of the network configuration and interfaces, ALL connections, gateways, UPS, logging recorders, interfaces to other equipment and any other pertinent system element;
- b. Description of the network elements to be connected to the system including 9-1-1 trunks, 10-digit emergency lines, administration lines, ring-down lines, remote maintenance lines and any other network connections that will be configured in the system;
- c. A description of the how the system programming will be initially accomplished and how it will be maintained on an ongoing basis;
- d. Integration Requirements to other equipment such as CAD, radio, and clock syncing equipment;

- e. Building modifications that the PSAP will have to make to accommodate the new or updated system.
3. Change Requests
    - a. A description of how changes to the SOW will be managed by the PSAP and the Contractor including identifying the authorized representatives that can approve changes and the specific process that will be followed to approve changes.
  4. Acceptance Testing
    - a. An Acceptance Test Plan with a clear description of the acceptance testing process that is consistent with the Contract Requirements including the System Acceptance and Authorization Checklist;
    - b. A description of how MACs are handled once Acceptance has been signed off by the authorized PSAP representative.
  5. Names of Responsible Parties and Contact Information
    - a. Names and contact information of all the responsible parties from the Contractor, PSAP and the CA 9-1-1 Branch.
  6. Responsibilities
    - a. Contractor's responsibilities;
    - b. PSAP responsibilities including a pre-installation checklist;
    - c. CA 9-1-1 Branch responsibilities.
  7. Revised PSAP Profile (with a copy to the CA 9-1-1 Branch MIS statewide provider);
  8. Installation Schedule
    - a. List of key dates beginning with the funding approval date from the CA 9-1-1 Branch;
    - b. Include equipment order date, delivery date, site readiness by PSAP date, programming freeze date, beginning of installation date, system in-service date, anticipated PSAP acceptance date and any other dates pertinent to the success of the project.
  9. Warranty Provisions
    - a. Acknowledgement of the terms of the warranty provisions of the Contract.
  10. Maintenance Plan
    - a. On-site and remote maintenance processes;
    - b. Description of how preventive maintenance will be provided;
    - c. Description of how remedial maintenance will be provided, including response times for major and minor outages;

- d. Description of the Minimum level of technical expertise that the maintenance technicians will have;
- e. Contact numbers to report trouble and the hours of availability for the contact center;
- f. A description of what is not covered in the maintenance plan and how those situations will be handled by the Contractor.

#### 11. Training

- a. A Training Plan that includes the following:
- b. A description of the training that will be provided to the PSAP management staff,
- c. Telecommunicators and PSAP technical support personnel;
- d. Description of the user manuals that will be provided by the Contractor;
- e. Description of the technical service manuals that will be provided by the Contractor.

#### 12. SOW Approval

- a. A sign-off page for the authorized PSAP representative to acknowledge concurrence with the content of the SOW.

#### 13. Appendices

- a. Site Certification Document
- b. The document that describes the building and environmental changes that the PSAP must make to accommodate the new or updated system;
- c. Floor Plan
- d. Diagrams of the room where the workstations will be installed and the telephone facilities room at the PSAP;
- e. Pricing and Terms
- f. A copy of the detailed quote from the Contractor for the project that includes specific part numbers from the multiple award contract, quantities, and maintenance costs;
- g. Forms
- h. Samples of the forms that will be used for the project such as change request forms, issue communications forms and any other applicable forms;
- i. Systems Acceptance and Authorization Checklist  
A copy of the System Acceptance and Authorization Checklist (SOW Attachment 4.1) to be completed and signed by the authorized PSAP representative upon acceptance. The executed form will be provided to the CA 9-1-1 Branch as documentation of system acceptance and beginning of the warranty period for the system.

**SOW ATTACHMENT 4.0: TURN-KEY 9-1-1 CPE SYSTEM  
 ACCEPTANCE AND AUTHORIZATION CHECKLIST**

**State of California**

**California 9-1-1 Emergency Communications Division**

**STAND ALONE CPE SYSTEM ACCEPTANCE AND AUTHORIZATION FORM**

TD-284 (Rev. 3/2017)

This document shall be used by the PSAP to validate that the purchased 9-1-1 system (equipment, software and all functionality) is acceptable.

All verification is to be completed by the PSAP authorized representative. Each item should be validated against the referenced IFB Requirement.

<b>MPA RFP Requirement Number</b>	<b>Requirement</b>	<b>PSAP Initial</b>
<b>Audio</b>		
6.3.1.5	Audio Quality	
6.3.1.6	Acoustic Noise	
6.3.1.7	Crosstalk	
<b>System Physical Requirements</b>		
6.3.2.2	Electrical Requirements	
6.3.2.3	Uninterruptable Power Supply	
6.3.2.4	Multiple Lines/Workstation Requirement	
6.3.2.5	CPE Expansion Requirement	
6.3.2.6	Printing Capability at Local PSAP	
<b>Intelligent Workstation Physical Requirements</b>		
6.3.3.1	IWS Hardware Requirements	
6.3.3.2	User Volume Controls	
6.3.3.3	Standard Keyboard	
6.3.3.4	Mouse	
6.3.3.5	Keyboard Arbitrator	
6.3.3.6	Monitor	
6.3.3.7	Auxiliary Keypad Dialer	
6.3.3.8	Headset/Handset Capability	
6.3.3.9	Radio Dispatch Integration	
6.3.3.10	IWS Wiring	
6.3.3.11	IWS Logging Recorder Interface	
<b>Interconnectivity</b>		
6.3.4.1	System Connections	
6.3.4.2	Wireless Connections	
6.3.4.3	ALI Retrieval	
6.3.4.4	Cabling	
6.3.4.5	CPE Interface to Existing Equipment	
6.3.4.6	Remote Data Transfer Interface	
6.3.4.7	Additional LCD/LED Monitor Interface	
6.3.4.8	Trunk and Line Interfaces	
6.3.4.9	Logging Recorder Interface	
6.3.4.10	IWS Based Logging Interface	
6.3.4.11	Local Maintenance Terminal Interface	
6.3.4.12	Interoperability with GIS Mapping System	
6.3.4.13	CAD and Mapping Interface	

**SOW ATTACHMENT 4.0: TURN-KEY 9-1-1 CPE SYSTEM  
 ACCEPTANCE AND AUTHORIZATION CHECKLIST**

System Features		
6.4.1.1	ALI Controller	
6.4.1.2	ANI/ALI Display	
6.4.1.3	Dynamic ANI/ALI Output	
6.4.1.4	ALI Error Reporting	
6.4.1.5	Abandoned Call Detail	
6.4.1.6	Internal Time Synchronization	
6.4.1.7	External Source Time Synchronization	
6.4.1.8	Caller Identification	
6.4.1.9	Wireless ALI- FCC 94-102-Phase I/Phase II One-button Call-back	
6.4.1.10	Voice over Internet Protocol (VoIP) Capability	
6.4.1.11	Complete Call Progress Detection	
6.4.1.12	TDD/TTY	
6.4.1.13	Multi-Media Requests for Assistance	
6.4.1.14	Remote Maintenance Access	
6.4.1.15	System Database Backup	
Call and System Detail Records		
6.4.2.1	Call Detail Record (CDR) Format	
6.4.2.2	Remote CDR Collection Service	
6.4.2.3	System Detail Records	
6.4.2.4	CDR and Quality of Service (QOS)	
Turn-Key System Functionality		
6.4.3.1	Controller Functionality	
6.4.3.2	Redundant Architecture	
6.4.3.3	Call-Path Associated Signaling (CAS) and Non Call-Path Signaling (NCAS)	
6.4.3.4	Administrative Line Support	
6.4.3.5	ALI Caching	
6.4.3.6	System Call Format Flexibility	
6.4.3.7	9-1-1 Emergency Star (*) Codes Transfers	
6.4.3.8	Selective Transfer	
6.4.3.9	Abandoned Call Information	
6.4.3.10	Automatic CDR	
Telecommunicator Call-Taking Functionality		
6.4.4.1 (1)	Hold	
6.4.4.1 (2)	Dial	
6.4.4.1 (3)	Re-dial	
6.4.4.1 (4)	Release	
6.4.4.1 (5)	Transfer	
6.4.4.1 (6)	Conference	
6.4.4.1 (7)	Speed Dial	
6.4.4.1 (8)	ALI Request	
6.4.4.1 (9)	ANI/ALI display (separate display is allowed)	
6.4.4.1 (10)	Four (4) line appearances or more	
6.4.4.1 (11)	Ten (10) multi-function programmable keys or more, programmed as telephone line appearance or a feature of the telephone set	
6.4.4.1 (12)	Headset/handset interface	
6.4.4.1 (13)	Volume control for inbound audio signal for headset/handset	
6.4.4.1 (14)	Volume control for outbound signal and sidetone for	

**SOW ATTACHMENT 4.0: TURN-KEY 9-1-1 CPE SYSTEM  
 ACCEPTANCE AND AUTHORIZATION CHECKLIST**

	headset/handset	
6.4.4.1 (15)	Volume Control for the ringer	
6.4.4.1 (16)	Call status indication (ringing, answered or both)	
6.4.4.2	Flash Transfer	
6.4.4.3	Conferencing Functionality	
6.4.4.4	Distinctive Ringing	
6.4.4.5	Call Queuing	
6.4.4.6	Last Stored Number Redial	
6.4.4.7	Pre-Arrival ALI	
6.4.4.8	Incoming 9-1-1 Emergency Call Display	
<b>Speed-Dial Functionalities</b>		
6.4.5.1	Speed Dial	
6.4.5.2	Speed-Dial Contacts	
6.4.5.3	Speed-Dial Icons	
6.4.5.4	Speed-Dial Shortcut Star (*) Codes	
<b>Additional Functionality</b>		
6.4.6.1	Voice Transfer	
6.4.6.2	Ring Volume	
6.4.6.3	Transmit Mute	
6.4.6.4	Release	
6.4.6.5	Radio System Interface	
<b>Integrated Recall Recording</b>		
6.4.7.1	Integrated Voice Recording (IVR)	
6.4.7.2	Integrated Recall Recording (IRR)	
6.4.7.3	IRR – Management of Old Recordings	
6.4.7.4	IRR – Call Type/Text Information	
6.4.7.5	IRR – Separate Recording and Playback	
6.4.7.6	IRR – Controls	
6.4.7.7	IRR – Speakers	
6.4.7.8	IRR – Radio Channel Recording	
<b>Intelligent Work Station Telephone (IWS) Functionality (Verify on each IWS)</b>		
6.4.8	TDD/TTY Capability	
6.4.9	Call/Line Indicators	
6.4.10	System Sounds and Icons	
6.4.11	Graphical User Interface (GUI)	
6.4.12	Help Documents	
6.4.13	Screen Layout - Lock	
6.4.14	Screen Layout - Restore	
6.4.15	Printing Capabilities	
6.4.16	Status Window	
6.4.17	Automatic Number Identification (ANI)	
6.4.18	Automatic Location Identification (ALI)	
6.4.19	Call Review	
6.4.20	Instant Messaging (IM)	
6.4.21	ALI Rebid	
6.4.22	ALI Parsing	
6.4.23	Conferencing Capabilities	
6.4.24	Call-back	
6.4.25	Hold	

**SOW ATTACHMENT 4.0: TURN-KEY 9-1-1 CPE SYSTEM  
ACCEPTANCE AND AUTHORIZATION CHECKLIST**

6.4.26	Forced Disconnect	
6.4.27	Audio Monitoring	
6.4.28	Barge In	
6.4.29	Make Busy	
6.4.30	Computer Telephony Integration Software Requirements	
6.4.31	Telecommunicator Log-on Roles and Permissions	

**SOW ATTACHMENT 4.0: TURN-KEY 9-1-1 CPE SYSTEM  
ACCEPTANCE AND AUTHORIZATION CHECKLIST**

Minor Discrepancies:

---

---

---

---

---

Tracking #: \_\_\_\_\_ Approved TD-288 Amount: \$ \_\_\_\_\_

As the authorized representative of:

\_\_\_\_\_ (PSAP name),

*I hereby acknowledge receipt, installation and satisfactory performance of the service and/or equipment. If minor discrepancies exist, but do not keep the equipment from performing in accordance with the contracted terms and conditions, these discrepancies are noted above.*

AUTHORIZED BY:

\_\_\_\_\_  
Signature Date

\_\_\_\_\_  
Printed/Typed Name Title

**IMMEDIATELY AFTER ACCEPTANCE:**

Submit the original TD-284, signed by the PSAP authorized representative to the Contractor and submit a copy to the CA 9-1-1 Division

**SOW ATTACHMENT 4.1: 9-1-1 CPE  
 HOST-REMOTE SYSTEM ACCEPTANCE AND AUTHORIZATION CHECKLIST**

**State of California**  
**California 9-1-1 Emergency Communications Division**  
**HOST-REMOTE SYSTEM ACCEPTANCE AND AUTHORIZATION FORM**  
 TD-284A (Rev. 3/2017)

This document shall be used by the PSAP to validate that the purchased 9-1-1 system (equipment, software and all functionality) is acceptable.

All verification is to be completed by the PSAP authorized representative. Each item should be validated against the referenced IFB Requirement.

<b>MPA RFP Requirement Number</b>	<b>Requirement</b>	<b>PSAP Initial</b>
<b>Audio</b>		
6.3.1.5	Audio Quality	
6.3.1.6	Acoustic Noise	
6.3.1.7	Crosstalk	
<b>System Physical Requirements</b>		
6.3.2.2	Electrical Requirements	
6.3.2.3	Uninterruptable Power Supply	
6.3.2.4	Multiple Lines/Workstation Requirement	
6.3.2.5	CPE Expansion Requirement	
6.3.2.6	Printing Capability at Local PSAP	
<b>Intelligent Workstation Physical Requirements</b>		
6.3.3.1	IWS Hardware Requirements	
6.3.3.2	User Volume Controls	
6.3.3.3	Standard Keyboard	
6.3.3.4	Mouse	
6.3.3.5	Keyboard Arbitrator	
6.3.3.6	Monitor	
6.3.3.7	Auxiliary Keypad Dialer	
6.3.3.8	Headset/Handset Capability	
6.3.3.9	Radio Dispatch Integration	
6.3.3.10	IWS Wiring	
6.3.3.11	IWS Logging Recorder Interface	
<b>Interconnectivity</b>		
6.3.4.1	System Connections	
6.3.4.2	Wireless Connections	
6.3.4.3	ALI Retrieval	
6.3.4.4	Cabling	
6.3.4.5	CPE Interface to Existing Equipment	
6.3.4.6	Remote Data Transfer Interface	
6.3.4.7	Additional LCD/LED Monitor Interface	
6.3.4.8	Trunk and Line Interfaces	
6.3.4.9	Logging Recorder Interface	
6.3.4.10	IWS Based Logging Interface	
6.3.4.11	Local Maintenance Terminal Interface	
6.3.4.12	Interoperability with GIS Mapping System	

**SOW ATTACHMENT 4.1: 9-1-1 CPE  
HOST-REMOTE SYSTEM ACCEPTANCE AND AUTHORIZATION CHECKLIST**

6.3.4.13	CAD and Mapping Interface	
<b>System Features</b>		
6.4.1.1	ALI Controller	
6.4.1.2	ANI/ALI Display	
6.4.1.3	Dynamic ANI/ALI Output	
6.4.1.4	ALI Error Reporting	
6.4.1.5	Abandoned Call Detail	
6.4.1.6	Internal Time Synchronization	
6.4.1.7	External Source Time Synchronization	
6.4.1.8	Caller Identification	
6.4.1.9	Wireless ALI- FCC 94-102-Phase I/Phase II One-button Call-back	
6.4.1.10	Voice over Internet Protocol (VoIP) Capability	
6.4.1.11	Complete Call Progress Detection	
6.4.1.12	TDD/TTY	
6.4.1.13	Multi-Media Requests for Assistance	
6.4.1.14	Remote Maintenance Access	
6.4.1.15	System Database Backup	
<b>Call and System Detail Records</b>		
6.4.2.1	Call Detail Record (CDR) Format	
6.4.2.2	Remote CDR Collection Service	
6.4.2.3	System Detail Records	
6.4.2.4	CDR and Quality of Service (QOS)	
<b>Turn-Key System Functionality</b>		
6.4.3.1	Controller Functionality	
6.4.3.2	Redundant Architecture	
6.4.3.3	Call-Path Associated Signaling (CAS) and Non Call-Path Signaling (NCAS)	
6.4.3.4	Administrative Line Support	
6.4.3.5	ALI Caching	
6.4.3.6	System Call Format Flexibility	
6.4.3.7	9-1-1 Emergency Star (*) Codes Transfers	
6.4.3.8	Selective Transfer	
6.4.3.9	Abandoned Call Information	
6.4.3.10	Automatic CDR	
<b>Telecommunicator Call-Taking Functionality</b>		
6.4.4.1 (1)	Hold	
6.4.4.1 (2)	Dial	
6.4.4.1 (3)	Re-dial	
6.4.4.1 (4)	Release	
6.4.4.1 (5)	Transfer	
6.4.4.1 (6)	Conference	
6.4.4.1 (7)	Speed Dial	
6.4.4.1 (8)	ALI Request	
6.4.4.1 (9)	ANI/ALI display (separate display is allowed)	
6.4.4.1 (10)	Four (4) line appearances or more	
6.4.4.1 (11)	Ten (10) multi-function programmable keys or more, programmed as telephone line appearance or a feature of the telephone set	
6.4.4.1 (12)	Headset/handset interface	
6.4.4.1 (13)	Volume control for inbound audio signal for headset/handset	

**SOW ATTACHMENT 4.1: 9-1-1 CPE  
 HOST-REMOTE SYSTEM ACCEPTANCE AND AUTHORIZATION CHECKLIST**

6.4.4.1 (14)	Volume control for outbound signal and sidetone for headset/handset	
6.4.4.1 (15)	Volume Control for the ringer	
6.4.4.1 (16)	Call status indication (ringing, answered or both)	
6.4.4.2	Flash Transfer	
6.4.4.3	Conferencing Functionality	
6.4.4.4	Distinctive Ringing	
6.4.4.5	Call Queuing	
6.4.4.6	Last Stored Number Redial	
6.4.4.7	Pre-Arrival ALI	
6.4.4.8	Incoming 9-1-1 Emergency Call Display	
<b>Speed-Dial Functionalities</b>		
6.4.5.1	Speed Dial	
6.4.5.2	Speed-Dial Contacts	
6.4.5.3	Speed-Dial Icons	
6.4.5.4	Speed-Dial Shortcut Star (*) Codes	
<b>Additional Functionality</b>		
6.4.6.1	Voice Transfer	
6.4.6.2	Ring Volume	
6.4.6.3	Transmit Mute	
6.4.6.4	Release	
6.4.6.5	Radio System Interface	
<b>Integrated Recall Recording</b>		
6.4.7.1	Integrated Voice Recording (IVR)	
6.4.7.2	Integrated Recall Recording (IRR)	
6.4.7.3	IRR – Management of Old Recordings	
6.4.7.4	IRR – Call Type/Text Information	
6.4.7.5	IRR – Separate Recording and Playback	
6.4.7.6	IRR – Controls	
6.4.7.7	IRR – Speakers	
6.4.7.8	IRR – Radio Channel Recording	
<b>Intelligent Work Station Telephone (IWS) Functionality (Verify on each IWS)</b>		
6.4.8	TDD/TTY Capability	
6.4.9	Call/Line Indicators	
6.4.10	System Sounds and Icons	
6.4.11	Graphical User Interface (GUI)	
6.4.12	Help Documents	
6.4.13	Screen Layout - Lock	
6.4.14	Screen Layout - Restore	
6.4.15	Printing Capabilities	
6.4.16	Status Window	
6.4.17	Automatic Number Identification (ANI)	
6.4.18	Automatic Location Identification (ALI)	
6.4.19	Call Review	
6.4.20	Instant Messaging (IM)	
6.4.21	ALI Rebid	
6.4.22	ALI Parsing	
6.4.23	Conferencing Capabilities	
6.4.24	Call-back	

**SOW ATTACHMENT 4.1: 9-1-1 CPE  
 HOST-REMOTE SYSTEM ACCEPTANCE AND AUTHORIZATION CHECKLIST**

6.4.25	Hold	
6.4.26	Forced Disconnect	
6.4.27	Audio Monitoring	
6.4.28	Barge In	
6.4.29	Make Busy	
6.4.30	Computer Telephony Integration Software Requirements	
6.4.31	Telecommunicator Log-on Roles and Permissions	
<b>9-1-1 CPE Host-Remote System</b>		
6.6.10	Service Component Architecture Call-Taking Mode	
6.6.11	Overflow Capability	
6.6.12	Remote Maintenance Access	
6.6.13	CDR and System Detail Records	
6.6.15	Radio Channel Recording	
6.6.17	Administration	
6.6.18	Time Synchronization	
6.6.21	Telecommunicator Log-on	
6.6.22	Logging Recorder Interface	
6.6.23	ACD	
6.6.24	MIS	
<b>Remote PSAP Requirements</b>		
6.7.3	User Profile Mobility	
6.7.4	CAD and Mapping Interface	
<b>Remote PSAP IWS Call-Handling Configuration and Functionality</b>		
6.8.2	Routing Display	

**SOW ATTACHMENT 4.1: 9-1-1 CPE  
HOST-REMOTE SYSTEM ACCEPTANCE AND AUTHORIZATION CHECKLIST**

Minor Discrepancies:

---

---

---

---

---

Tracking #: \_\_\_\_\_ Approved TD-288 Amount: \$ \_\_\_\_\_

As the authorized representative of:

\_\_\_\_\_ (PSAP name),

*I hereby acknowledge receipt, installation and satisfactory performance of the service and/or equipment. If minor discrepancies exist, but do not keep the equipment from performing in accordance with the contracted terms and conditions, these discrepancies are noted above.*

AUTHORIZED BY:

\_\_\_\_\_  
Signature Date

\_\_\_\_\_  
Printed/Typed Name Title

**IMMEDIATELY AFTER ACCEPTANCE:**

Submit the original TD-284, signed by the PSAP authorized representative to the Contractor and submit a copy to the CA 9-1-1 Division

### ATTACHMENT 5.0 REQUIRED CALL DETAIL RECORD (CDR) ELEMENTS

The following CDR elements must be provided by the Contractor's 9-1-1 CPE no more than six (6) seconds following the completion of the call (trunk release) following standards defined in NENA Technical Information Document on XML namespaces, NENA 02-503 Issue 1, and the current NENA schema which at the time of release is 4.3.1

The example below demonstrates the format and data elements for CDR information. Following the data elements is a table providing type of data expected and definitions for the elements. Data shown in the sample below is for demonstration purposes.

#### SAMPLE XML FORMAT:

```
<?xml version="1.0" encoding="UTF-8"?>
<!-- edited with XMLSpy v2016 rel. 2 sp1 (x64) (http://www.altova.com) -->
<xs:schema xmlns:xs="http://www.w3.org/2001/XMLSchema">
  <xs:annotation>
    <xs:documentation>California Schema for Call Detail Records (CDR) requirements and CA Required Automatic Location Information (ALI)
    payload</xs:documentation>
  </xs:annotation>
  <xs:element name="CACallDetailRecord">
    <xs:complexType>
      <xs:sequence>
        <xs:element name="SequenceNumber" type="xs:unsignedLong"/>
        <xs:element name="PSAPName" type="xs:string"/>
        <xs:element name="AgencyType" type="xs:string"/>
        <xs:simpleType>
          <xs:restriction base="xs:string">
            <xs:enumeration value="Primary"/>
            <xs:enumeration value="Secondary"/>
          </xs:restriction>
        </xs:simpleType>
      </xs:sequence>
    </xs:complexType>
  </xs:element>
</xs:schema>
```

```
        </xs:simpleType>
    </xs:element>
    <xs:element name="AgencyAffiliation" block="restriction"/>
        <xs:simpleType>
            <xs:restriction base="xs:string">
                <xs:enumeration value="CalFire"/>
                <xs:enumeration value="CHP"/>
                <xs:enumeration value="Consolidated"/>
                <xs:enumeration value="Fire"/>
                <xs:enumeration value="Medical"/>
                <xs:enumeration value="Military"/>
                <xs:enumeration value="Police"/>
                <xs:enumeration value="Sheriff"/>
                <xs:enumeration value="University"/>
            </xs:restriction>
        </xs:simpleType>
    </xs:element>
    <xs:element name="FCCID" type="xs:unsignedInt"/>
    <xs:element name="ANI" type="xs:unsignedLong"/>
    <xs:element name="TN" type="xs:unsignedLong"/>
    <xs:element name="TimeZoneOffset" type="xs:string"/>
    <xs:element name="RouteInformation">
        <xs:complexType>
            <xs:sequence>
                <xs:element name="TransportType" type="xs:string"/>
                <xs:element name="RouteName" type="xs:string"/>
                <xs:element name="LineNumber" type="xs:string"/>
            </xs:sequence>
        </xs:complexType>
    </xs:element>
</xs:element>
```

```
<xs:element name="NetworkProvider" type="xs:string"/>
<xs:element name="SignallingType" type="xs:string"/>
<xs:element name="Non911">
  <xs:complexType>
    <xs:sequence>
      <xs:element name="IsOutbound" type="xs:boolean"/>
      <xs:element name="IsEmergency" type="xs:boolean"/>
      <xs:element name="IsRingback" type="xs:boolean"/>
    </xs:sequence>
  </xs:complexType>
</xs:element>
<xs:element name="IsTDDTTY" type="xs:boolean"/>
<xs:element name="MediaType" block="restriction">
  <xs:simpleType>
    <xs:restriction base="xs:string">
      <xs:enumeration value="VOICE"/>
      <xs:enumeration value="TDDTTY"/>
      <xs:enumeration value="SMS"/>
      <xs:enumeration value="MMS"/>
      <xs:enumeration value="VIDEO"/>
      <xs:enumeration value="APP"/>
    </xs:restriction>
  </xs:simpleType>
</xs:element>
<xs:element name="Conversation" type="xs:string" minOccurs="0"/>
</xs:sequence>
</xs:complexType>
```

```
</xs:element>
<xs:element name="CallEvents">
  <xs:complexType>
    <xs:sequence minOccurs="1" maxOccurs="1">
      <xs:element name="TrunkSeizure">
        <xs:complexType>
          <xs:sequence minOccurs="1" maxOccurs="1">
            <xs:element name="EventNumber" type="xs:unsignedShort"/>
            <xs:element name="DateTime" type="xs:dateTime"/>
            <xs:element name="SipDetails">
              <xs:complexType>
                <xs:sequence>
                  <xs:element name="SipType" type="xs:string"/>
                  <xs:element name="SipId" type="xs:unsignedInt"/>
                  <xs:element name="SourceIP" type="xs:string"/>
                  <xs:element name="DestinationIp" type="xs:string"/>
                  <xs:element name="RawSipMessage"
                    type="xs:string"/>
                </xs:sequence>
              </xs:complexType>
            </xs:element>
          </xs:sequence>
        </xs:complexType>
      </xs:element>
    </xs:sequence>
  </xs:complexType>
</xs:element>
<xs:element name="SetUp">
  <xs:complexType>
    <xs:sequence minOccurs="1" maxOccurs="1">
      <xs:element name="EventNumber" type="xs:unsignedShort"/>
    </xs:sequence>
  </xs:complexType>
</xs:element>
```

```
<xs:element name="DateTimeStart" type="xs:dateTime"/>
<xs:element name="DateTimeEnd" type="xs:dateTime"/>
</xs:sequence>
</xs:complexType>
</xs:element>
<xs:element name="Ring">
  <xs:complexType>
    <xs:sequence minOccurs="0" maxOccurs="unbounded">
      <xs:element name="EventNumber" type="xs:unsignedShort" minOccurs="1"
maxOccurs="1"/>
      <xs:element name="DateTimeStart" type="xs:dateTime" minOccurs="1"
maxOccurs="1"/>
      <xs:element name="DateTimeEnd" type="xs:dateTime" minOccurs="1"
maxOccurs="1"/>
      <xs:element name="Position" type="xs:string" minOccurs="1"
maxOccurs="1"/>
      <xs:element name="OperatorId" type="xs:string" minOccurs="1"
maxOccurs="1"/>
      <xs:element name="OperatorName" type="xs:string" minOccurs="1"
maxOccurs="1"/>
      <xs:element name="OperatorRole" type="xs:string" minOccurs="1"
maxOccurs="1"/>
    </xs:sequence>
  </xs:complexType>
</xs:element>
<xs:element name="Queue">
  <xs:complexType>
    <xs:sequence minOccurs="0" maxOccurs="unbounded">
      <xs:element name="EventNumber" type="xs:unsignedShort"/>
      <xs:element name="DateTimeStart" type="xs:dateTime"/>
    </xs:sequence>
  </xs:complexType>
</xs:element>
```

```
        <xs:element name="DateTimeEnd" type="xs:dateTime"/>
        <xs:element name="QueueName" type="xs:string"/>
        <xs:element name="QueueNumber" type="xs:string"/>
    </xs:sequence>
</xs:complexType>
</xs:element>
<xs:element name="WelcomeMessage">
    <xs:complexType>
        <xs:sequence minOccurs="0" maxOccurs="unbounded">
            <xs:element name="EventNumber" type="xs:unsignedShort"/>
            <xs:element name="DateTimeStart" type="xs:dateTime"/>
            <xs:element name="DateTimeEnd" type="xs:dateTime"/>
        </xs:sequence>
    </xs:complexType>
</xs:element>
<xs:element name="InitialAnswer">
    <xs:complexType>
        <xs:sequence minOccurs="0" maxOccurs="1">
            <xs:element name="EventNumber" type="xs:unsignedShort"/>
            <xs:element name="DateTime" type="xs:dateTime"/>
            <xs:element name="Position" type="xs:string"/>
            <xs:element name="OperatorId" type="xs:string"/>
            <xs:element name="OperatorName" type="xs:string"/>
            <xs:element name="OperatorRole" type="xs:string"/>
        </xs:sequence>
    </xs:complexType>
</xs:element>
```

```
<xs:element name="StationConnect">
  <xs:complexType>
    <xs:sequence minOccurs="0" maxOccurs="unbounded">
      <xs:element name="EventNumber" type="xs:unsignedShort"/>
      <xs:element name="DateTimeStart" type="xs:dateTime"/>
      <xs:element name="DateTimeEnd" type="xs:dateTime"/>
      <xs:element name="Position" type="xs:string"/>
      <xs:element name="OperatorId" type="xs:string"/>
      <xs:element name="OperatorName" type="xs:string"/>
      <xs:element name="OperatorRole" type="xs:string"/>
    </xs:sequence>
  </xs:complexType>
</xs:element>
<xs:element name="Transfer">
  <xs:complexType>
    <xs:sequence minOccurs="0" maxOccurs="unbounded">
      <xs:element name="Position" type="xs:string"/>
      <xs:element name="OperatorId" type="xs:string"/>
      <xs:element name="OperatorName" type="xs:string"/>
      <xs:element name="OperatorRole" type="xs:string"/>
      <xs:element name="EventNumber" type="xs:unsignedShort"/>
      <xs:element name="DateTimeStart" type="xs:dateTime"/>
      <xs:element name="DateTimeConnected" type="xs:dateTime"/>
      <xs:element name="DateTimeEnd" type="xs:dateTime"/>
      <xs:element name="DialedDigits" type="xs:string"/>
      <xs:element name="QuickDialLabel" type="xs:string"/>
      <xs:element name="TransferType" block="restriction"/>
    </xs:sequence>
  </xs:complexType>
</xs:element>
```

```
<xs:simpleType>
  <xs:restriction base="xs:string">
    <xs:enumeration value="Internal"/>
    <xs:enumeration value="External"/>
  </xs:restriction>
</xs:simpleType>
</xs:element>
</xs:sequence>
</xs:complexType>
</xs:element>
<xs:element name="Conference">
  <xs:complexType>
    <xs:sequence minOccurs="0" maxOccurs="unbounded">
      <xs:element name="Position" type="xs:string"/>
      <xs:element name="OperatorId" type="xs:string"/>
      <xs:element name="OperatorName" type="xs:string"/>
      <xs:element name="OperatorRole" type="xs:string"/>
      <xs:element name="EventNumber" type="xs:unsignedShort"/>
      <xs:element name="DateTimeStart" type="xs:dateTime"/>
      <xs:element name="DateTimeConnected" type="xs:dateTime"/>
      <xs:element name="DateTimeEnd" type="xs:dateTime"/>
      <xs:element name="DialedDigits" type="xs:string"/>
      <xs:element name="QuickDialLabel" type="xs:string"/>
      <xs:element name="ConferenceType" type="xs:string"/>
    </xs:sequence>
  </xs:complexType>
</xs:element>
```

```
<xs:element name="Mute">
  <xs:complexType>
    <xs:sequence minOccurs="0" maxOccurs="unbounded">
      <xs:element name="EventNumber" type="xs:unsignedShort"/>
      <xs:element name="DateTimeStart" type="xs:dateTime"/>
      <xs:element name="DateTimeEnd" type="xs:dateTime"/>
      <xs:element name="Position" type="xs:string"/>
      <xs:element name="OperatorId" type="xs:string"/>
      <xs:element name="OperatorName" type="xs:string"/>
      <xs:element name="OperatorRole" type="xs:string"/>
    </xs:sequence>
  </xs:complexType>
</xs:element>
<xs:element name="Hold">
  <xs:complexType>
    <xs:sequence minOccurs="0" maxOccurs="unbounded">
      <xs:element name="EventNumber" type="xs:unsignedShort"/>
      <xs:element name="DateTimeStart" type="xs:dateTime"/>
      <xs:element name="DateTimeEnd" type="xs:dateTime"/>
      <xs:element name="Position" type="xs:string"/>
      <xs:element name="OperatorId" type="xs:string"/>
      <xs:element name="OperatorName" type="xs:string"/>
      <xs:element name="OperatorRole" type="xs:string"/>
    </xs:sequence>
  </xs:complexType>
</xs:element>
<xs:element name="Park">
```

```
<xs:complexType>
  <xs:sequence minOccurs="0" maxOccurs="unbounded">
    <xs:element name="EventNumber" type="xs:unsignedShort"/>
    <xs:element name="DateTimeStart" type="xs:dateTime"/>
    <xs:element name="DateTimeEnd" type="xs:dateTime"/>
    <xs:element name="Position" type="xs:string"/>
    <xs:element name="OperatorId" type="xs:string"/>
    <xs:element name="OperatorName" type="xs:string"/>
    <xs:element name="OperatorRole" type="xs:string"/>
  </xs:sequence>
</xs:complexType>
</xs:element>
<xs:element name="AbandonedCall">
  <xs:complexType>
    <xs:sequence minOccurs="0" maxOccurs="unbounded">
      <xs:element name="EventNumber" type="xs:unsignedShort"/>
      <xs:element name="DateTime" type="xs:dateTime"/>
    </xs:sequence>
  </xs:complexType>
</xs:element>
<xs:element name="DisconnectTime">
  <xs:complexType>
    <xs:sequence minOccurs="0" maxOccurs="unbounded">
      <xs:element name="DisconnectedBy" block="restriction">
        <xs:simpleType>
          <xs:restriction base="xs:string">
            <xs:enumeration value="Caller"/>
          </xs:restriction>
        </xs:simpleType>
      </xs:element>
    </xs:sequence>
  </xs:complexType>
</xs:element>
```

```
        <xs:enumeration value="Operator"/>
      </xs:restriction>
    </xs:simpleType>
  </xs:element>
  <xs:element name="EventNumber" type="xs:unsignedShort"/>
  <xs:element name="DateTime" type="xs:dateTime"/>
  <xs:element name="Position" type="xs:string"/>
  <xs:element name="OperatorId" type="xs:string"/>
  <xs:element name="OperatorName" type="xs:string"/>
  <xs:element name="OperatorRole" type="xs:string"/>
</xs:sequence>
</xs:complexType>
</xs:element>
<xs:element name="TrunkReleaseTime">
  <xs:complexType>
    <xs:sequence minOccurs="0" maxOccurs="1">
      <xs:element name="EventNumber" type="xs:unsignedShort"/>
      <xs:element name="DateTime" type="xs:dateTime"/>
    </xs:sequence>
  </xs:complexType>
</xs:element>
<xs:element name="Finished">
  <xs:complexType>
    <xs:sequence minOccurs="0" maxOccurs="1">
      <xs:element name="EventNumber" type="xs:unsignedShort"/>
      <xs:element name="DateTime" type="xs:dateTime"/>
    </xs:sequence>
  </xs:complexType>
</xs:element>
```

```
        </xs:complexType>
    </xs:element>
</xs:sequence>
</xs:complexType>
</xs:element>
<xs:element name="CARRequiredRawALI">
    <xs:complexType>
        <xs:sequence minOccurs="0" maxOccurs="1">
            <xs:element name="RAWALI" type="xs:string" minOccurs="0" maxOccurs="unbounded"/>
        </xs:sequence>
    </xs:complexType>
</xs:element>
<xs:element name="SystemEvents">
    <xs:complexType>
        <xs:sequence minOccurs="1" maxOccurs="unbounded">
            <xs:element name="HourlyControllerTimeStamp">
                <xs:complexType>
                    <xs:sequence minOccurs="1" maxOccurs="unbounded">
                        <xs:element name="DateTime" type="xs:dateTime" />
                    </xs:sequence>
                </xs:complexType>
            </xs:element>
            <xs:element name="OperatorLogin">
                <xs:complexType>
                    <xs:sequence minOccurs="1" maxOccurs="unbounded">
                        <xs:element name="DateTime" type="xs:dateTime" />
                        <xs:element name="Position" type="xs:string" />
                    </xs:sequence>
                </xs:complexType>
            </xs:element>
        </xs:sequence>
    </xs:complexType>
</xs:element>
</xs:sequence>
</xs:complexType>
</xs:element>
```

```
<xs:element name="OperatorId" type="xs:string" />
<xs:element name="OperatorName" type="xs:string" />
<xs:element name="OperatorRole" type="xs:string" />
<xs:element name="QueueName" type="xs:string" />
<xs:element name="QueueNumber" type="xs:string" />
</xs:sequence>
</xs:complexType>
</xs:element>
<xs:element name="OperatorLogout">
  <xs:complexType>
    <xs:sequence minOccurs="1" maxOccurs="unbounded">
      <xs:element name="DateTime" type="xs:dateTime" />
      <xs:element name="Position" type="xs:string" />
      <xs:element name="OperatorId" type="xs:string" />
      <xs:element name="OperatorName" type="xs:string" />
      <xs:element name="OperatorRole" type="xs:string" />
      <xs:element name="QueueName" type="xs:string" />
      <xs:element name="QueueNumber" type="xs:string" />
    </xs:sequence>
  </xs:complexType>
</xs:element>
<xs:element name="OperatorStatusChange">
  <xs:complexType>
    <xs:sequence minOccurs="1" maxOccurs="unbounded">
      <xs:element name="DateTime" type="xs:dateTime" />
      <xs:element name="Position" type="xs:string" />
      <xs:element name="OperatorId" type="xs:string" />
    </xs:sequence>
  </xs:complexType>
</xs:element>
```

```
<xs:element name="OperatorName" type="xs:string" />
<xs:element name="OperatorRole" type="xs:string" />
<xs:element name="QueueName" type="xs:string" />
<xs:element name="QueueNumber" type="xs:string" />
<xs:element name="Status" block="restriction">
  <xs:simpleType>
    <xs:restriction base="xs:string">
      <xs:enumeration value="Ready"/>
      <xs:enumeration value="NotReady"/>
    </xs:restriction>
  </xs:simpleType>
</xs:element>
<xs:element name="ReasonCode" type="xs:string" />
</xs:sequence>
</xs:complexType>
</xs:element>
</xs:sequence>
</xs:complexType>
</xs:element>
</xs:sequence>
</xs:complexType>
</xs:element>
</xs:sequence>
</xs:complexType>
</xs:element>
</xs:schema>
```

**SOW ATTACHMENT 6.0: CALL DATA RECORD FORMAT**

The CACallDetailRecord is the root element name for the California XML Schema for 9-1-1 call detail records.

Root element	Level 1	Level 2	Level 3	Level 4	Data Format	Data Definition
CACallDetailRecord	-	-	-	-	n/a	The root element of the call detail record schema.

The following sub-levels are the children and sub-elements from the root element.

Level 1	Level 2	Level 3	Level 4	Data Format	Data Definition
SequenceNumber	-	-	-	unsignedLong	A positive number from 0 to 32 or 64 bits in length number. This is assigned to each CDR in sequential order to detect if any calls were skipped or duplicated. No reset of this number is allowed
PSAPName	-	-	-	string	The name of the PSAP according to the FCC PSAP Registry
AgencyType	-	-	-	enumeration	Defines the PSAP using only the following string values "Primary" or "Secondary"
AgencyAffiliation	-	-	-	enumeration	Defines the PSAP's affiliation type using only the following string values: CalFire, CHP, Consolidated, Fire, Medical, Military, Police, Sheriff, University
FCCID	-	-	-	unsignedInt	The unsigned positive number identified as a 6 to 8 digit integer from the FCC PSAP Registry
ANI	-	-	-	unsignedLong	The 10 digit automatic number identifier of the caller, with no hyphens
TN	-	-	-	unsignedLong	The telephone number of the caller with no hyphens or the number dialed by the call taker on an outbound call
TimeZoneOffset	-	-	-	string	The time offset from Universal Time Coordinate (UTC). Off daylight savings time this would be -08:00 and on daylight savings time this would be -07:00.
RouteInformation	-	-	-	n/a	Denotes the route information of the call with the following 9 sub elements at level 2.
RouteInformation	TransportType	-	-	string	Denotes the ingress network Transport type, as identified by the call handling system, such as: CAMA, T1
RouteInformation	RouteName	-	-	string	Identifier of the type of call, such as: 911, Admin, Ring Down

Level 1	Level 2	Level 3	Level 4	Data Format	Data Definition
RouteInformation	LineNumber	-	-	string	The numeric identified of the trunk/line the call comes in from (by Selective Router and trunk billing number preferred for 911 trunks)
RouteInformation	NetworkProvider	-	-	string	Service provider of the routing network (ATT, Frontier, West, ComTech, etc.)
RouteInformation	SignallingType	-	-	string	Identify if call is coming by SS7, SIP, SMS, MPLS
RouteInformation	Non911	IsOutbound	-	boolean	TRUE/FALSE Identifies if the non911 call is outbound or not
RouteInformation	Non911	IsEmergency	-	boolean	TRUE/FALSE Identifies if the non911 call came on 10-digit emergency lines or not
RouteInformation	Non911	IsRingback	-	boolean	TRUE/FALSE Identifies if the non911 call is an abandoned call ringback or not
RouteInformation	IsTDDTTY	-	-	boolean	TRUE/FALSE Identifies if the call is a TDDTTY call or not
RouteInformation	MediaType	-	-	enumeration	Defines the call media type using only the following string values: VOICE, TDDTTY, SMS, MMS, VIDEO, APP
RouteInformation	Conversation	-	-	string	The contents of the conversation for media types that contain a written conversation, such as TDDTTY and SMS
CallEvents	-	-	-	n/a	Denotes the call events of the call with the following 9 sub elements at level 2.
CallEvents	TrunkSeizure	-	-	n/a	The details of the time when the call is received at the Controller and the trunk is seized.
CallEvents	TrunkSeizure	EventNumber	-	unsignedShort	The unique number assigned to the call within a system and used for all events and reporting related to the original call.
CallEvents	TrunkSeizure	DateTime	-	dateTime	Date and time of the event
CallEvents	TrunkSeizure	SipDetails	-	string	SIP details as defined by the 5 sub elements below
CallEvents	TrunkSeizure	SipDetails	SipType	string	The media type of the SIP message body
CallEvents	TrunkSeizure	SipDetails	SipId	unsignedInt	SIP Message-ID unique identifier within the header
CallEvents	TrunkSeizure	SipDetails	SourceIP	string	The IP address of IPv4 or Ipv6
CallEvents	TrunkSeizure	SipDetails	DestinationIP	string	The IP address of IPv4 or Ipv6
CallEvents	TrunkSeizure	SipDetails	RawSipMessage	string	The raw SIP message

Level 1	Level 2	Level 3	Level 4	Data Format	Data Definition
CallEvents	SetUp	-	-	-	The details of the time when the call is in the controller being set up for delivery to the call taker or queue
CallEvents	SetUp	EventNumber	-	unsignedShort	The unique number assigned to the call within a system and used for all events and reporting related to the original call.
CallEvents	SetUp	DateTimeStart	-	dateTime	Date and time of the event start
CallEvents	SetUp	DateTimeEnd	-	dateTime	Date and time of the event end
CallEvents	Ring	-	-	-	The details related to the call when the call is ringing/presented at the call taker's position
CallEvents	Ring	EventNumber	-	unsignedShort	The unique number assigned to the call within a system and used for all events and reporting related to the original call.
CallEvents	Ring	DateTimeStart	-	dateTime	Date and time of the event start
CallEvents	Ring	DateTimeEnd	-	dateTime	Date and time of the event end
CallEvents	Ring	Position	-	string	Call taker's position number in the form of 0001, 0002 up to 9999
CallEvents	Ring	OperatorId	-	string	The name or number id of the call taker operator who is signed on
CallEvents	Ring	OperatorName	-	string	The name or number id of the call taker operator who is signed on
CallEvents	Ring	OperatorRole	-	string	The role to which the call taker is assigned or logged into specific to this event.
CallEvents	Queue	-	-	-	The details related to the call when in/out of queue
CallEvents	Queue	EventNumber	-	unsignedShort	The unique number assigned to the call within a system and used for all events and reporting related to the original call.
CallEvents	Queue	DateTimeStart	-	dateTime	Date and time of the event start
CallEvents	Queue	DateTimeEnd	-	dateTime	Date and time of the event end
CallEvents	Queue	QueueName	-	string	The name of the queue such as 911, Admin, Spanish
CallEvents	Queue	QueueNumber	-	string	The assigned queue number
CallEvents	WelcomeMessage	-	-	-	The details related to the time that the call is treated with an introductory message

Level 1	Level 2	Level 3	Level 4	Data Format	Data Definition
CallEvents	WelcomeMessage	EventNumber	-	unsignedShort	The unique number assigned to the call within a system and used for all events and reporting related to the original call.
CallEvents	WelcomeMessage	DateTimeStart	-	dateTime	Date and time of the event start
CallEvents	WelcomeMessage	DateTimeEnd	-	dateTime	Date and time of the event end
CallEvents	InitialAnswer	-	-	-	The details related to the time at which the call taker answers the call
CallEvents	InitialAnswer	EventNumber	-	unsignedShort	The unique number assigned to the call within a system and used for all events and reporting related to the original call.
CallEvents	InitialAnswer	DateTime	-	dateTime	Date and time of the event
CallEvents	InitialAnswer	Position	-	string	Call taker's position number in the form of 0001, 0002 up to 9999
CallEvents	InitialAnswer	OperatorId	-	string	The name or number id of the call taker operator who is signed on
CallEvents	InitialAnswer	OperatorName	-	string	The name or number id of the call taker operator who is signed on
CallEvents	InitialAnswer	OperatorRole	-	string	The role to which the call taker is assigned or logged into specific to this event.
CallEvents	StationConnect	-	-	-	The details related to the time at which an intelligent workstation (within the CPE system) connects to a call
CallEvents	StationConnect	EventNumber	-	unsignedShort	The unique number assigned to the call within a system and used for all events and reporting related to the original call.
CallEvents	StationConnect	DateTimeStart	-	dateTime	Date and time of the event start
CallEvents	StationConnect	DateTimeEnd	-	dateTime	Date and time of the event end
CallEvents	StationConnect	Position	-	string	Call taker's position number in the form of 0001, 0002 up to 9999
CallEvents	StationConnect	OperatorId	-	string	The name or number id of the call taker operator who is signed on
CallEvents	StationConnect	OperatorName	-	string	The name or number id of the call taker operator who is signed on
CallEvents	StationConnect	OperatorRole	-	string	The role to which the call taker is assigned or logged into specific to this event.

Level 1	Level 2	Level 3	Level 4	Data Format	Data Definition
CallEvents	Transfer	-	-	-	The details related to a call transfer
CallEvents	Transfer	EventNumber	-	unsignedShort	The unique number assigned to the call within a system and used for all events and reporting related to the original call.
CallEvents	Transfer	DateTimeStart	-	dateTime	Date and time of the event start
CallEvents	Transfer	DateTimeConnected	-	dateTime	Date and time when the call is connected to the transfer to party
CallEvents	Transfer	DateTimeEnd	-	dateTime	Date and time of the event end
CallEvents	Transfer	Position	-	string	Call taker's position number in the form of 0001, 0002 up to 9999
CallEvents	Transfer	OperatorId	-	string	The name or number id of the call taker operator who is signed on
CallEvents	Transfer	OperatorName	-	string	The name or number id of the call taker operator who is signed on
CallEvents	Transfer	OperatorRole	-	string	The role to which the call taker is assigned or logged into specific to this event.
CallEvents	Transfer	DialedDigits	-	string	Flash hook or similar transfer indicator with * code, transfer number, or 10 digit dialed number
CallEvents	Transfer	QuickDialLabel	-	string	The name of the entity associated with the dialed digits (i.e. PSAP, external emergency resource)
CallEvents	Transfer	TransferType	-	enumeration	Defines the call transfer type using only the following string values: Internal, External
CallEvents	Conference	-	-	-	The details related to a conference session
CallEvents	Conference	EventNumber	-	unsignedShort	The unique number assigned to the call within a system and used for all events and reporting related to the original call.
CallEvents	Conference	DateTimeStart	-	dateTime	Date and time of the event start
CallEvents	Conference	DateTimeConnected	-	dateTime	Date and time when the call is connected to the transfer to party
CallEvents	Conference	DateTimeEnd	-	dateTime	Date and time of the event end
CallEvents	Conference	Position	-	string	Call taker's position number in the form of 0001, 0002 up to 9999
CallEvents	Conference	OperatorId	-	string	The name or number id of the call taker operator who is signed on

Level 1	Level 2	Level 3	Level 4	Data Format	Data Definition
CallEvents	Conference	OperatorName	-	string	The name or number id of the call taker operator who is signed on
CallEvents	Conference	OperatorRole	-	string	The role to which the call taker is assigned or logged into specific to this event.
CallEvents	Conference	DialedDigits	-	string	Dialed digits or number being conferenced
CallEvents	Conference	QuickDialLabel	-	string	The name of the entity associated with the dialed digits (i.e. station number)
CallEvents	Conference	ConferenceType	-	string	Defines the call conference type such as external (outside the CPE system), internal (within the CPE system), etc.
CallEvents	Mute	-	-	-	The details related to a call that is placed on mute
CallEvents	Mute	EventNumber	-	unsignedShort	The unique number assigned to the call within a system and used for all events and reporting related to the original call.
CallEvents	Mute	DateTimeStart	-	dateTime	Date and time of the event start
CallEvents	Mute	DateTimeEnd	-	dateTime	Date and time of the event end
CallEvents	Mute	Position	-	string	Call taker's position number in the form of 0001, 0002 up to 9999
CallEvents	Mute	OperatorId	-	string	The name or number id of the call taker operator who is signed on
CallEvents	Mute	OperatorName	-	string	The name or number id of the call taker operator who is signed on
CallEvents	Mute	OperatorRole	-	string	The role to which the call taker is assigned or logged into specific to this event.
CallEvents	Hold	-	-	-	The details related to a call that is placed on Hold
CallEvents	Hold	EventNumber	-	unsignedShort	The unique number assigned to the call within a system and used for all events and reporting related to the original call.
CallEvents	Hold	DateTimeStart	-	dateTime	Date and time of the event start
CallEvents	Hold	DateTimeEnd	-	dateTime	Date and time of the event end
CallEvents	Hold	Position	-	string	Call taker's position number in the form of 0001, 0002 up to 9999

Level 1	Level 2	Level 3	Level 4	Data Format	Data Definition
CallEvents	Hold	OperatorId	-	string	The name or number id of the call taker operator who is signed on
CallEvents	Hold	OperatorName	-	string	The name or number id of the call taker operator who is signed on
CallEvents	Hold	OperatorRole	-	string	The role to which the call taker is assigned or logged into specific to this event.
CallEvents	Park	-	-	-	The details related to a call that is placed on Hold
CallEvents	Park	EventNumber	-	unsignedShort	The unique number assigned to the call within a system and used for all events and reporting related to the original call.
CallEvents	Park	DateTimeStart	-	dateTime	Date and time of the event start
CallEvents	Park	DateTimeEnd	-	dateTime	Date and time of the event end
CallEvents	Park	Position	-	string	Call taker's position number in the form of 0001, 0002 up to 9999
CallEvents	Park	OperatorId	-	string	The name or number id of the call taker operator who is signed on
CallEvents	Park	OperatorName	-	string	The name or number id of the call taker operator who is signed on
CallEvents	Park	OperatorRole	-	string	The role to which the call taker is assigned or logged into specific to this event.
CallEvents	AbandonedCall	-	-	-	Any call in which the caller hangs up prior to their call being answered by a PSAP call taker. Callers who hang up after their call has been treated by an ACD or placed into queue, but prior to their call being answered by a call taker, shall be counted as an abandoned call. This is the time at which the caller abandons the call prior to being answered by the call taker, including the time at which a call enters an abandoned call queue or list, if applicable.
CallEvents	AbandonedCall	EventNumber	-	unsignedShort	The unique number assigned to the call within a system and used for all events and reporting related to the original call.
CallEvents	AbandonedCall	DateTime	-	dateTime	Date and time of the event

Level 1	Level 2	Level 3	Level 4	Data Format	Data Definition
CallEvents	DisconnectTime	-	-	-	The time at which the call taker or the caller disconnects from the call. There may be multiple disconnect times for different call takers for the same event number.
CallEvents	DisconnectTime	DisconnectedBy	-	enumeration	Defines the call transfer type using only the following string values: Internal, External
CallEvents	DisconnectTime	EventNumber	-	unsignedShort	The unique number assigned to the call within a system and used for all events and reporting related to the original call.
CallEvents	DisconnectTime	DateTime	-	dateTime	Date and time of the event
CallEvents	DisconnectTime	Position	-	string	Call taker's position number in the form of 0001, 0002 up to 9999
CallEvents	DisconnectTime	OperatorId	-	string	The name or number id of the call taker operator who is signed on
CallEvents	DisconnectTime	OperatorName	-	string	The name or number id of the call taker operator who is signed on
CallEvents	DisconnectTime	OperatorRole	-	string	The role to which the call taker is assigned or logged into specific to this event.
CallEvents	TrunkReleaseTime	-	-	-	The time at which the line is released and available for the next call.
CallEvents	TrunkReleaseTime	EventNumber	-	unsignedShort	The unique number assigned to the call within a system and used for all events and reporting related to the original call.
CallEvents	TrunkReleaseTime	DateTime	-	dateTime	Date and time of the event
CallEvents	Finished	-	-	-	The time at which the call data processing concludes within the call handling system
CallEvents	Finished	EventNumber	-	unsignedShort	The unique number assigned to the call within a system and used for all events and reporting related to the original call.
CallEvents	Finished	DateTime	-	dateTime	Date and time of the event
CARRequiredRawALI		-	-	n/a	Denotes the California Required Automatic Location Information of the call with the following sub element at level 2. Must comply with California Format 04 ALI Display Standards, including future updates or revisions.

Level 1	Level 2	Level 3	Level 4	Data Format	Data Definition
CARRequiredRawALI	RAWALI	-	-	string	The ALI dump out of the call handling system as received from the ALI provider. Must comply with California Format 04 ALI Display Standards, including future updates or revisions. Minimum occurrence of 0 and maximum occurrence is unbounded. Must be provided for the initial ALI bid, the final ALI bid, and each rebid for all calls where ALI is applicable.
SystemEvents	-	-	-	n/a	Denotes the system events of the CPE with the following 4 sub elements at level 2.
SystemEvents	HourlyControllerTimeStamp	-	-	-	The mandatory hourly time stamp generated by the call handling system controller
SystemEvents	HourlyControllerTimeStamp	DateTime	-	dateTime	Date and time of the event
SystemEvents	OperatorLogin	-	-	-	The details related to the call taker when logging in to the CPE system
SystemEvents	OperatorLogin	DateTime	-	dateTime	Date and time of the event
SystemEvents	OperatorLogin	Position	-	string	Call taker's position number in the form of 0001, 0002 up to 9999
SystemEvents	OperatorLogin	OperatorId	-	string	The name or number id of the call taker operator who is signed on
SystemEvents	OperatorLogin	OperatorName	-	string	The name or number id of the call taker operator who is signed on
SystemEvents	OperatorLogin	OperatorRole	-	string	The role to which the call taker is assigned or logged into specific to this event.
SystemEvents	OperatorLogin	QueueName	-	string	The name of the queue such as 911, Admin, Spanish
SystemEvents	OperatorLogin	QueueNumber	-	string	The assigned queue number
SystemEvents	OperatorLogout	-	-	-	The details related to the call taker when logging out of the CPE system
SystemEvents	OperatorLogout	DateTime	-	dateTime	Date and time of the event
SystemEvents	OperatorLogout	Position	-	string	Call taker's position number in the form of 0001, 0002 up to 9999
SystemEvents	OperatorLogout	OperatorId	-	string	The name or number id of the call taker operator who is signed on

Level 1	Level 2	Level 3	Level 4	Data Format	Data Definition
SystemEvents	OperatorLogout	OperatorName	-	string	The name or number id of the call taker operator who is signed on
SystemEvents	OperatorLogout	OperatorRole	-	string	The role to which the call taker is assigned or logged into specific to this event.
SystemEvents	OperatorLogout	QueueName	-	string	The name of the queue such as 911, Admin, Spanish
SystemEvents	OperatorLogout	QueueNumber	-	string	The assigned queue number
SystemEvents	OperatorStatusChange	-	-	-	The details related to the call taker when the status of that call taker changes from one state to another
SystemEvents	OperatorStatusChange	DateTime	-	dateTime	Date and time of the event
SystemEvents	OperatorStatusChange	Position	-	string	Call taker's position number in the form of 0001, 0002 up to 9999
SystemEvents	OperatorStatusChange	OperatorId	-	string	The name or number id of the call taker operator who is signed on
SystemEvents	OperatorStatusChange	OperatorName	-	string	The name or number id of the call taker operator who is signed on
SystemEvents	OperatorStatusChange	OperatorRole	-	string	The role to which the call taker is assigned or logged into specific to this event.
SystemEvents	OperatorStatusChange	QueueName	-	string	The name of the queue such as 911, Admin, Spanish
SystemEvents	OperatorStatusChange	QueueNumber	-	string	The assigned queue number
SystemEvents	OperatorStatusChange	Status	-	enumeration	Defines the call taker status using only the following string values: Ready, NotReady

---

**APPENDIX B**  
**BUDGET DETAIL, INVOICING AND PAYMENT PROVISIONS**

---

- 1) Contractors shall be limited to 12 months of back billing on all systems, services and functionality ordered under the Contract. Invoices presented more than 12 months after the formal acceptance of the system, service or functionality will not be considered valid and will not be paid.
- 2) Invoices shall be submitted as specified on the individual PO as submitted to the Contractor. The Contractor shall render invoices for total monthly maintenance charges following the month for which the charges accrue. Invoices to the CA 9-1-1 Branch must include those items listed in the GSPD-401IT, Item #29 and may require additional information. Payment for goods or services rendered outside the original SOW of a PO (change orders) will require an amendment to the PO or a new PO.
- 3) Contractor shall provide individual invoices for each project under this Contract that shall include, at a minimum, the following fields:
  - a) Invoice Date
  - b) CA PSAP Name and Address
  - c) Tracking Number
  - d) Naming Convention (provided by CA 9-1-1 Branch)
  - e) System Installation Date
  - f) System Acceptance Date
  - g) Maintenance Start Date (after the one year warranty period)
  - h) Cost (including equipment, installation, and training)
  - i) Sales Tax
- 4) All invoices submitted to the CA 9-1-1 Branch as a result of a PO based on this Contract will be billed separately from other charges the Contractor may currently be billing.
- 5) The CA 9-1-1 Branch will provide naming conventions to the CA PSAP for site identification and all invoices will use the same naming convention.
- 6) Equipment accountability will be by model number, serial number and physical location.
- 7) The Contractor shall make every effort to reconcile incorrect invoices within 30 calendar days from notification by the CA PSAP or CA 9-1-1 Branch of the discrepancy. The CA PSAP or CA 9-1-1

Branch may withhold payments of all invoices issued as a result of this Contract until the discrepancies have been corrected.

- 8) It shall be PSAP's sole determination as to whether all equipment has been successfully installed and accepted. Signed acceptance is required from the PSAP before processing an invoice for payment.
- 9) Upon acceptance of each deliverable, the Contractor will submit an invoice for payment associated with the individual payment amounts. Payment shall not exceed the Cost Worksheet.
- 10) For Equipment, invoices shall be submitted in triplicate including costs charged for each Line Item's Equipment Unit Price.
- 11) For Monthly Maintenance, invoices shall be submitted in triplicate, monthly in arrears, identifying the PSAP, Contractor and equipment information.,
- 12) The Contractor costs related to items such as travel and per diem are costs of the Contractor, shall be inclusive of the hourly rate bid, and will not be paid separately as part of this Agreement.
- 13) Submit invoices, in triplicate, with reference to the Contract number #4145-6 to:

**California Governor's Office of Emergency Services**  
**Attention: Accounting**  
**3650 Schriever Ave.**  
**Mather, CA 95655**

- 14) It is mutually agreed that if the Budget Act of the current year and/or any subsequent years covered under this Agreement does not appropriate sufficient funds for the program, this Agreement shall be of no further force and effect. In this event, Cal OES shall have no liability to pay any funds whatsoever to the Contractor or to furnish any other considerations under this Agreement and Contractor shall not be obligated to perform any provisions of this Agreement.
- 15) If funding for any fiscal year is reduced or deleted by the Budget Act for purposes of this program, Cal OES shall have the option to either cancel this Contract with no liability occurring to Cal OES, or offer a Contract amendment to the Contractor to reflect the reduced amount.
- 16) Payment will be made in accordance with, and within the time specified in, Government Code Chapter 4.5, commencing with Section 927. Payment to small/micro businesses shall be made in accordance with and within the time specified in Chapter 4.5, Government Code 927 et seq.

**EXHIBIT 16 - #1**

**9-1-1 CPE BASIC TURN-KEY STAND-ALONE SYSTEM COST WORKSHEET**

<b>Instructions: Bidder must follow 1 through 7 when filling out this Cost Worksheet.</b>									
1) Bidder shall insert their Company name into the "Bidder's Name" field and Model name for the proposed system into the "Manufacturer/Model" field.									
2) For all Line Items, the Bidder shall provide pricing for one unit of measure for evaluation.									
3) The elements included in the Basic CPE Turn-key Configurations are detailed within the IFB Section 6.5. Bidder shall insert the price for the 9-1-1 CPE Basic Turn-key System Configuration based on the defined number of positions per each Line Item #. For configurations over 20 positions during initial installation or adding additional positions after installation, with all the same requirements as above.									
4) The Equipment Unit Price shall include all equipment consisting of, but not limited to, preconfigured hardware, software, ancillary materials, and one year warranty.									
5) The Implentation Unit Price shall include the cost of staging, installation, wiring, testing and training.									
6) Bidders are to provide a Monthly Maintenance rate for years 2 through 5 for each Line Item #. The Monthly Maintenance begins, following acceptance of the implementation and after the one year warranty is complete. Monthly Maintenance shall include any updates (hot fix/patches) to hardware and software, and local PSAP site service required to keep the Line Item # fully operational which may include parts as needed to replace obsolete technology.									
7) Bidder shall provide Additional Monthly Maintenance rate for Years 6 and 7, if needed by the PSAP or State.									

Bidder's Name: Pacific Bell Telephone Company dba AT&T California, AT&T Wholesale, AT&T Datacom

Manufacturer/Model: West Safety Services / VIPER System

(a.)	(b.)	(c.)	(d.)	(e.)	(f.)	(g.)	(h.)	(i.)	(j.)
Line Item #	Turn-key System with defined Number of Intelligent Workstations (Positions)	Unit of Measure Each	Basic Turn-key System Equipment Unit Price	Implementation Unit Price	Monthly Maint. Rate Years 2-5	TOTAL 5 Year Turn-key System $c*[d+e+(f*48)]$	Monthly Maint. Rate Year 6	Monthly Maint. Rate Year 7	TOTAL Year 6 & 7 Maintenance $(h*12)+(i*12)$
1	Turn-key System - 2 Positons	1	\$136,390.83	\$49,589.92	\$380.01	\$204,221.41	\$402.66	\$402.66	\$9,663.75
2	Turn-key System - 3 Positions	1	\$159,908.59	\$53,240.66	\$521.10	\$238,162.23	\$554.55	\$554.55	\$13,309.21

3	Turn-key System - 4 Positions	1	\$177,576.77	\$57,258.02	\$659.90	\$266,509.74	\$703.80	\$703.80	\$16,891.23
4	Turn-key System - 5 Positions	1	\$202,213.42	\$60,931.09	\$796.39	\$301,371.11	\$850.41	\$850.41	\$20,409.80
5	Turn-key System - 6 Positions	1	\$220,372.42	\$62,782.30	\$930.58	\$327,822.62	\$994.37	\$994.37	\$23,864.92
6	Turn-key System - 7 Positions	1	\$243,826.77	\$69,067.44	\$1,062.48	\$363,893.08	\$1,135.69	\$1,135.69	\$27,256.59
7	Turn-key System - 8 Positions	1	\$261,313.00	\$70,450.40	\$1,192.07	\$388,982.88	\$1,274.37	\$1,274.37	\$30,584.83
8	Turn-key System - 9 Positions	1	\$284,710.83	\$75,037.65	\$1,319.37	\$423,078.24	\$1,410.40	\$1,410.40	\$33,849.61
9	Turn-key System - 10 Positions	1	\$319,561.19	\$79,392.44	\$1,450.93	\$468,598.33	\$1,550.35	\$1,550.35	\$37,208.45
10	Turn-key System - 11 Positions	1	\$344,575.83	\$83,065.37	\$1,573.63	\$503,175.49	\$1,681.10	\$1,681.10	\$40,346.35
11	Turn-key System - 12 Positions	1	\$364,013.84	\$84,488.65	\$1,694.03	\$529,816.04	\$1,809.20	\$1,809.20	\$43,420.80
12	Turn-key System - 13 Positions	1	\$387,309.45	\$90,773.79	\$1,812.14	\$565,065.71	\$1,934.66	\$1,934.66	\$46,431.80
13	Turn-key System - 14 Positions	1	\$406,696.65	\$92,665.32	\$1,927.94	\$591,903.04	\$2,057.47	\$2,057.47	\$49,379.36
14	Turn-key System - 15 Positions	1	\$427,829.77	\$98,846.43	\$2,041.44	\$624,665.50	\$2,177.64	\$2,177.64	\$52,263.47
15	Turn-key System - 16 Positions	1	\$447,805.27	\$102,904.11	\$2,152.65	\$654,036.58	\$2,295.17	\$2,295.17	\$55,084.14
16	Turn-key System - 17 Positions	1	\$472,065.08	\$107,045.44	\$2,261.56	\$687,665.28	\$2,410.06	\$2,410.06	\$57,841.36
17	Turn-key System - 18 Positions	1	\$491,452.24	\$108,936.98	\$2,375.06	\$714,392.22	\$2,530.23	\$2,530.23	\$60,725.48
18	Turn-key System - 19 Positions	1	\$512,341.48	\$115,181.79	\$2,472.48	\$746,202.13	\$2,599.08	\$2,599.08	\$62,377.97
19	Turn-key System - 20 Positions	1	\$531,703.35	\$117,073.33	\$2,582.15	\$772,719.88	\$2,747.66	\$2,747.66	\$65,943.84
20	At the time of installation, the cost of an additional IWS position per Section 6 for a Basic Turn-key system over 20 positions including all connectivity within the PSAP.	1	\$36,920.03	\$2,554.72	\$186.20	\$48,412.58	\$197.53	\$197.53	\$4,740.63
21	After installation, the cost of an additional IWS per Section 6 for a Basic Turn-key system, including all hardware, software, training, cabling, and any additional materials necessary for install.	1	\$36,994.65	\$6,285.76	\$186.20	\$52,218.24	\$197.53	\$197.53	\$4,740.63
<b>SUBTOTAL:</b>						<b>\$9,472,912.32</b>	<b>SUBTOTAL:</b>		<b>\$756,334.21</b>

<b>TAB #1: GRAND TOTAL of TURN-KEY CPE WITH 5YR MAINT + 2YR MAINT:</b>								<b>\$10,229,246.53</b>	
--	--	--	--	--	--	--	--	------------------------	--

**EXHIBIT 16 - #2**  
**9-1-1 CPE SYSTEM ITEMIZED COST WORKSHEET**

<b>Instructions: Bidder must follow 1 through 7 when filling out this Cost Worksheet.</b>									
1) Bidder shall insert their Company name into the "Bidder's Name" field.									
2) For all Line Items, the Bidder shall provide pricing for one unit of measure for evaluation.									
3) These itemized items may be applied for Turn-key or Host-Remote Systems. Bidders are to provide their price for the equipment with features and functionality described for each line item. The Equipment Unit Price shall include all equipment, software, and one year warranty.									
4) The Equipment Unit Price shall include all equipment consisting of, but not limited to, preconfigured hardware, software, ancillary materials, and one year warranty.									
5) The Implementation Unit Price shall include the cost of staging, installation, wiring, testing and training.									
6) Bidders are to provide a Monthly Maintenance rate for years 2 through 5 for each Line Item #. The Monthly Maintenance begins, following acceptance of the implementation and after the one year warranty is complete. Monthly Maintenance shall include any updates (hot fix/patches) to hardware and software, and local PSAP site service required to keep the Line Item # fully operational which may include parts as needed to replace obsolete technology.									
7) Bidder shall provide Additional Monthly Maintenance rate for Years 6 and 7, if needed by the PSAP or State.									

Bidder's Name: Pacific Bell Telephone Company dba AT&T California, AT&T Wholesale, AT&T Datacom \_\_\_\_\_

(a.)	(b.)	(c.)	(d.)	(e.)	(f.)	(g.)	(h.)	(i.)	(j.)
Line Item #	Itemized Description	Unit of Measure Each	Equipment Unit Price	Implementation Unit Price	Monthly Maint. Rate Years 2 - 5	Total 5 Year Itemized $c*[d+e+(f*48)]$	Monthly Maint. Rate Year 6	Monthly Maint. Rate Year 7	TOTAL Year 6 & 7 Maintenance $(h*12)+(i*12)$
1	Laser jet printer, (LAN Network ready) capable of printing 15 pages per minute.	1	\$711.48	\$365.64	\$4.15	\$1,276.33	\$4.77	\$4.77	\$114.55
2	19" computer monitor to work with IWS.	1	\$389.10	\$124.92	\$2.27	\$622.97	\$2.61	\$2.61	\$62.65
3	22" computer monitor to work with IWS.	1	\$401.44	\$125.17	\$2.34	\$639.01	\$2.69	\$2.69	\$64.63
4	24" computer monitor to work with IWS.	1	\$457.53	\$126.29	\$2.67	\$711.92	\$3.07	\$3.07	\$73.66
5	Legacy Network Interface card with a minimum of 4 ports to accommodate Centralized Automatic Message Accounting (CAMA) or 10-Digit.	1	\$3,362.50	\$535.80	\$24.52	\$5,075.18	\$28.20	\$28.20	\$676.70

6	IP interface gateway/appliance	1	\$371.25	\$1,881.63	\$2.71	\$2,382.81	\$3.11	\$3.11	\$74.71
7	Chassis to mount interface line cards with all required interconnect cabling.	1	\$742.50	\$951.95	\$5.41	\$1,954.33	\$6.23	\$6.23	\$149.43
8	Uninterrupted Power Supply (UPS) for backroom equipment.	1	\$5,725.00	\$496.20	\$16.70	\$7,022.70	\$19.20	\$19.20	\$460.86
9	Uninterrupted Power Supply (UPS) for an IWS.	1	\$555.00	\$479.65	\$3.24	\$1,190.05	\$3.72	\$3.72	\$89.36
						<b>SUBTOTAL:</b>	<b>\$20,875.29</b>	<b>SUBTOTAL:</b>	<b>\$1,766.55</b>

<b>TAB #2: GRAND TOTAL of ITEMIZED ITEMS WITH 5YR MAINT + 2YR MAINT:</b>								<b>\$22,641.83</b>
--	--	--	--	--	--	--	--	--------------------

**EXHIBIT 16 - #3**

**9-1-1 CPE HOST-REMOTE SYSTEM COST WORKSHEET**

<b>Instructions: Bidder must follow 1 through 7 when filling out this Cost Worksheet.</b>										
1) Bidder shall insert their Company name into the "Bidder's Name" field and Model name for the proposed system into the "Manufacturer/Model" field.										
2) For all Line Items, the Bidder shall provide pricing for one unit of measure for evaluation.										
3) The requirements for the 911 CPE Host-Remote Systems are detailed within the IFB Sections 6.6 - 6.8. Bidder shall insert the price for the individual host Line Item # and configurations with the defined number of positions per each Line Item #. For configurations over 20 positions during initial installation and adding additional positions after installation, with all the same requirements as above.										
4) The Equipment Unit Price shall include all equipment consisting of, but not limited to, preconfigured hardware, software, ancillary materials, and one year										
5) The Implementation Unit Price shall include the cost of staging, installation, wiring, testing and training.										
6) Bidders are to provide a Monthly Maintenance rate for years 2 through 5 for each Line Item #. The Monthly Maintenance begins, following acceptance of the implementation and after the one year warranty is complete. Monthly Maintenance shall include any updates (hot fix/patches) to hardware and software, and local PSAP site service required to keep the Line Item # fully operational which may include parts as needed to replace obsolete technology.										
7) Bidder shall provide Additional Monthly Maintenance rate for Years 6 and 7, if needed by the PSAP or State.										

Bidder's Name: Pacific Bell Telephone Company dba AT&T California, AT&T Wholesale, AT&T Datacom

Manufacturer/Model: West Safety Services / VIPER System

(a.)	(b.)	(c.)	(d.)	(e.)	(f.)	(g.)	(h.)	(i.)	(j.)
Line Item #	Configuration Title	Unit of Measure Each	Equipment Unit Price	Implementation Unit Price	Monthly Maint. Rate Years 2-5	TOTAL Year Host-Remote System Items c*[d+e+(f*48)]	Monthly Maint. Rate Year 6	Monthly Maint. Rate Year 7	TOTAL Year 6 & 7 Maintenance (h*12)+(i*12)
1	The first Host of a Host-Remote System, including all backroom equipment as described in Sections 6.6 - 6.8	1	\$101,691.99	\$21,024.06	\$161.00	\$130,444.05	\$172.49	\$172.49	\$4,139.85

2	The second or additional Host of a Host-Remote System, including all backroom equipment as described in Section 6.6 - 6.8	1	\$83,740.98	\$20,674.37	\$154.44	\$111,828.36	\$165.93	\$165.93	\$3,982.35
3	Remote PSAP with 1 position including all connectivity within the PSAP	1	\$75,444.01	\$33,060.55	\$260.79	\$121,022.38	\$272.11	\$272.11	\$6,530.63
4	Remote PSAP with 2 positions including all connectivity within the PSAP.	1	\$122,186.37	\$47,130.05	\$353.76	\$186,297.08	\$376.41	\$376.41	\$9,033.75
5	Remote PSAP with 3 positions including all connectivity within the PSAP.	1	\$145,873.02	\$50,788.17	\$494.85	\$220,414.17	\$528.30	\$528.30	\$12,679.21
6	Remote PSAP with 4 positions including all connectivity within the PSAP.	1	\$163,933.17	\$53,619.17	\$633.65	\$247,967.30	\$677.55	\$677.55	\$16,261.23
7	Remote PSAP with 5 positions including all connectivity within the PSAP.	1	\$189,032.67	\$60,657.92	\$770.14	\$286,657.20	\$824.16	\$824.16	\$19,779.80
8	Remote PSAP with 6 positions including all connectivity within the PSAP.	1	\$207,611.83	\$62,517.64	\$904.33	\$313,537.38	\$968.12	\$968.12	\$23,234.92
9	Remote PSAP with 7 positions including all connectivity within the PSAP.	1	\$231,459.64	\$68,808.52	\$1,036.23	\$350,007.03	\$1,109.44	\$1,109.44	\$26,626.59
10	Remote PSAP with 8 positions including all connectivity within the PSAP.	1	\$249,369.78	\$70,200.28	\$1,165.82	\$375,529.54	\$1,248.12	\$1,248.12	\$29,954.83
11	Remote PSAP with 9 positions including all connectivity within the PSAP.	1	\$273,165.92	\$74,794.33	\$1,293.12	\$410,030.01	\$1,384.15	\$1,384.15	\$33,219.61
12	Remote PSAP with 10 positions including all connectivity within the PSAP.	1	\$298,372.84	\$78,961.19	\$1,418.12	\$445,403.73	\$1,517.54	\$1,517.54	\$36,420.95
13	Remote PSAP with 11 positions including all connectivity within the PSAP.	1	\$321,723.28	\$82,601.33	\$1,540.82	\$478,283.91	\$1,648.29	\$1,648.29	\$39,558.85
14	Remote PSAP with 12 positions including all connectivity within the PSAP.	1	\$341,580.23	\$84,033.38	\$1,661.22	\$505,352.17	\$1,776.39	\$1,776.39	\$42,633.30
15	Remote PSAP with 13 positions including all connectivity within the PSAP.	1	\$369,884.10	\$90,414.15	\$1,779.32	\$545,705.73	\$1,901.85	\$1,901.85	\$45,644.30

16	Remote PSAP with 14 positions including all connectivity within the PSAP.	1	\$389,689.80	\$92,314.17	\$1,895.13	\$572,970.03	\$2,024.66	\$2,024.66	\$48,591.86
17	Remote PSAP with 15 positions including all connectivity within the PSAP.	1	\$411,225.85	\$98,501.08	\$2,008.63	\$606,141.24	\$2,144.83	\$2,144.83	\$51,475.97
18	Remote PSAP with 16 positions including all connectivity within the PSAP.	1	\$435,489.08	\$102,565.89	\$2,119.84	\$639,807.18	\$2,262.36	\$2,262.36	\$54,296.64
19	Remote PSAP with 17 positions including all connectivity within the PSAP.	1	\$455,280.29	\$106,694.98	\$2,228.75	\$668,955.03	\$2,377.24	\$2,377.24	\$57,053.86
20	Remote PSAP with 18 positions including all connectivity within the PSAP.	1	\$476,077.95	\$108,614.32	\$2,342.25	\$697,120.27	\$2,497.42	\$2,497.42	\$59,937.98
21	Remote PSAP with 19 positions including all connectivity within the PSAP.	1	\$497,372.61	\$114,864.90	\$2,439.66	\$729,341.37	\$2,599.08	\$2,599.08	\$62,377.97
22	Remote PSAP with 20 positions including all connectivity within the PSAP.	1	\$517,153.76	\$116,764.92	\$2,549.34	\$756,286.88	\$2,714.85	\$2,714.85	\$65,156.34
23	At the time of installation, the cost to add an additional position for a Remote PSAP configuration over 20 positions in a Host-Remote system including all connectivity within the PSAP. Priced as each.	1	\$36,971.67	\$2,810.61	\$186.20	\$48,720.12	\$197.53	\$197.53	\$4,740.63
24	After intial installation, the cost to add an additional position to a Remote PSAP within a Host-Remote system including all hardware, software, training, cabling and any additional materials necessary for install. Priced as each.	1	\$36,971.67	\$6,281.84	\$186.20	\$52,191.34	\$197.53	\$197.53	\$4,740.63
25	After intial installation, the cost at an individual Host to add another PSAP to an existing Host-Remote system. Priced as each.	1	\$331.33	\$14,044.54	\$52.60	\$16,900.87	\$31.25	\$31.25	\$750.00
						<b>SUBTOTAL:</b>	<b>\$9,516,914.35</b>	<b>SUBTOTAL:</b>	<b>\$758,822.04</b>

<b>TAB #3: GRAND TOTAL of HOST-REMOTE INCLUDING 5YR MAINT + 2YR MAINT:</b>	<b>\$10,275,736.39</b>
--	------------------------

**EXHIBIT 16 - #4  
 APPLICATIONS AND PERIPHERALS COST WORKSHEET**

<b>Instructions: Bidder must follow 1 through 7 when filling out this Cost Worksheet.</b>
1) Bidder shall insert their Company name into the "Bidder's Name" field.
2) For all Line Items, the Bidder shall provide pricing for one unit of measure for evaluation.
3) Bidders are to provide their price for the equipment with features and functionality described for each line item per IFB Section 6.9 which are applicable to the Telecommunicator call taking operations.
4) The Equipment Unit Price shall include all equipment consisting of, but not limited to, preconfigured hardware, software, ancillary materials, and one year warranty.
5) The Implentation Unit Price shall include the cost of staging, installation, wiring, testing and training.
6) Bidders are to provide a Monthly Maintenance rate for years 2 through 5 for each Line Item #. The Monthly Maintenance begins, following acceptance of the implementation and after the one year warranty is complete. Monthly Maintenance shall include any updates (hot fix/patches) to hardware and software, and local PSAP site service required to keep the Line Item # fully operational which may include parts as needed to replace obsolete technology.
7) Bidder shall provide Additional Monthly Maintenance rate for Years 6 and 7, if needed by the PSAP or State.

Bidder's Name: Pacific Bell Telephone Company dba AT&T California, AT&T Wholesale, AT&T Datacom

(a.)	(b.)	(c.)	(d.)	(e.)	(f.)	(g.)	(h.)	(i.)	(j.)
Line Item #	Application or Peripheral	Unit of Measure	Equipment Unit Price	Implementation Unit Price	Monthly Maint. Rate Years 2-5	TOTAL 5 Year App/Peripheral Items c*[d+e+(f*48)]	Additional Monthly Maint. Rate Year 6	Additional Monthly Maint. Rate Year 7	TOTAL Year 6 & 7 Maintenance (h*12)+(i*12)
1	Geographical Information System (GIS) Mapping System functionality including all required server hardware and software, including a license as needed, <b>in the PSAP backroom or Host location.</b>	1	\$26,243.75	\$10,185.50	\$390.93	\$55,194.09	\$409.43	\$409.43	\$9,826.41

2	Geographical Information System (GIS) Mapping System functionality <b>per IWS</b> including all required hardware, software, including a license as needed, training, cabling and any additional materials for install.	1	\$3,731.56	\$1,010.65	\$123.33	\$10,662.05	\$141.83	\$409.43	\$6,615.16
3	Digital Voice Logging Recorder (DVLR) with minimum of 12 analog/VoIP channels including all required hardware, software, including a license as needed, training, cabling and any additional materials for install.	1	\$13,382.53	\$10,405.65	\$592.71	\$52,238.18	\$592.71	\$592.71	\$14,225.00
4	Digital Voice Logging Recorder (DVLR) with minimum of 32 analog/VoIP channels including all required hardware, software, including a license as needed, training, cabling and any additional materials for install.	1	\$31,230.03	\$13,748.40	\$927.86	\$89,515.93	\$927.86	\$927.86	\$22,268.75
5	Digital Voice Logging Recorder (DVLR) with minimum of 64 analog/VoIP channels including all required hardware, software, including a license as needed, training, cabling and any additional materials for install.	1	\$48,705.03	\$19,246.80	\$1,326.30	\$131,614.33	\$1,326.30	\$1,326.30	\$31,831.25
6	Digital Voice Logging Recorder (DVLR) with minimum of 96 analog/VoIP channels including all required hardware, software, including a license as needed, training, cabling and any additional materials for install.	1	\$62,130.03	\$24,495.20	\$1,695.57	\$168,012.73	\$1,695.57	\$1,695.57	\$40,693.75
7	External Time Source per Section 6.9.3.	1	\$14,800.00	\$3,869.15	\$15.42	\$19,409.31	\$17.73	\$17.73	\$425.59
8	Real-Time Call Status System per Section 6.9.4	1	\$7,785.00	\$6,071.60	\$15.42	\$14,596.76	\$17.73	\$17.73	\$425.59
9	Real-Time Call Status Display per Section 6.9.5	1	\$2,855.51	\$525.66	\$15.42	\$4,121.33	\$17.73	\$17.73	\$425.59
10	Integrated SMS Text Function Activation <b>in the PSAP or Host location</b> with set-up and training.	1	\$2,343.75	\$3,717.75	\$138.54	\$12,711.42	\$144.32	\$144.32	\$3,463.70

11	Integrated SMS Text Function <b>per IWS</b> with set-up and training.	1	\$1,200.00	\$2,137.10	\$157.08	\$10,876.94	\$168.64	\$168.64	\$4,047.41
12	IP Router with Firewall for IP calls or TCC connection.	1	\$3,500.00	\$4,793.80	\$46.25	\$10,513.80	\$53.19	\$53.19	\$1,276.50
13	Call-taker Headset per Section 6.9.7.	1	\$338.75	\$6.78	\$15.42	\$1,085.69	\$17.73	\$17.73	\$425.59
14	IP Phone Set per Section 6.9.8	1	\$2,419.41	\$420.09	\$61.67	\$5,799.67	\$70.92	\$70.92	\$1,702.09
15	Automatic Call Distribution (ACD) Site Activation functionality including all required server hardware and software, including a license as needed, <b>in the PSAP backroom or Host location.</b>	1	\$0.00	\$6,619.64	\$123.33	\$12,539.48	\$141.83	\$141.83	\$3,403.91
16	Automatic Call Distribution (ACD) functionality <b>per IWS/Agent</b> including all required hardware, software, including a license as needed, training, cabling and any additional materials for install.	1	\$2,246.25	\$162.06	\$93.00	\$6,872.31	\$106.95	\$106.95	\$2,566.80
17	Management Information System (MIS) functionality including all required server hardware and software, including a license as needed, <b>in the PSAP backroom or Host location.</b>	1	\$1,687.50	\$11,527.81	\$123.33	\$19,135.15	\$141.83	\$141.83	\$3,403.91
18	Management Information System (MIS) functionality <b>per IWS</b> including all required hardware, software, including a license as needed, training, cabling and any additional materials for install.	1	\$559.61	\$245.47	\$113.31	\$6,243.84	\$123.31	\$123.31	\$2,959.39
						<b>SUBTOTAL:</b>	<b>\$631,142.99</b>	<b>SUBTOTAL:</b>	<b>\$149,986.40</b>

<b>TAB #4: GRAND TOTAL of APPLICATIONS AND PERIPHERALS WITH 5YR MAINT + 2YR MAINT:</b>	<b>\$781,129.39</b>
--	---------------------

**EXHIBIT 16 - #5  
 LABOR RATES COST WORKSHEET**

Bidder's Name: Pacific Bell Telephone Company dba AT&T California, AT&T Wholesale, AT&T Datacom

(a.)	(b.)	(c.)	(d.)	(e.)	(f.)	(g.)	(h.)	(i.)
Line Item #	Classification	Hourly Rate Years 1-3	Hourly Rate Year 4	Hourly Rate Year 5	Hourly Rate Year 6	Hourly Rate Year 7	Estimated annual hours	Evaluation Total [(3*c)+(d+e+f+g)]*h
1	Factory-Trained Certified Technician	\$185.00	\$185.00	\$185.00	\$185.00	\$185.00	100	\$129,500.00
2	Technician	\$165.00	\$165.00	\$165.00	\$165.00	\$165.00	50	\$57,750.00
3	System Engineer	\$200.00	\$200.00	\$200.00	\$200.00	\$200.00	40	\$56,000.00
4	Project Manager	\$200.00	\$200.00	\$200.00	\$200.00	\$200.00	40	\$56,000.00
<b>TAB #5 LABOR RATES EVALUATION TOTAL:</b>								<b>\$299,250.00</b>

**EXHIBIT 16 - #6**  
**SUMMARY COST WORKSHEET FOR TABS 1-5.**

Bidder's Name: Pacific Bell Telephone Company dba AT&T California, AT&T Wholes:

<b>TAB #1: GRAND TOTAL of TURN-KEY CPE WITH 5YR MAINT + 2YR MAINT:</b>	\$10,229,246.53
<b>TAB #2: GRAND TOTAL of ITEMIZED ITEMS WITH 5YR MAINT + 2YR MAINT:</b>	\$22,641.83
<b>TAB #3: GRAND TOTAL of HOST-REMOTE INCLUDING 5YR MAINT + 2YR MAINT:</b>	\$10,275,736.39
<b>TAB #4: GRAND TOTAL of APPLICATIONS AND PERIPHERALS WITH 5YR MAINT + 2YR MAINT:</b>	\$781,129.39
<b>TAB #5: LABOR RATES EVALUATION TOTAL:</b>	\$299,250.00
<b>GRAND TOTAL:</b>	\$21,608,004.14

**State of California**  
**California 9-1-1 Emergency Communications Division**  
**STAND ALONE CPE SYSTEM ACCEPTANCE AND AUTHORIZATION FORM**  
 TD-284 (Rev. 3/2017)

This document shall be used by the PSAP to validate that the purchased 9-1-1 system (equipment, software and all functionality) is acceptable.

All verification is to be completed by the PSAP authorized representative. Each item should be validated against the referenced MPA IFB Requirement. The MPA IFB Requirements can be downloaded from the CA 9-1-1 Division website at:

<http://www.caloes.ca.gov/cal-oes-divisions/public-safety-communications/ca-9-1-1-emergencycommunications-branch/ca-9-1-1-services-contracts>

MPA RFP Requirement Number	Requirement	PSAP Initial
<b>Audio</b>		
6.3.1.5	Audio Quality	<i>Rubio</i>
6.3.1.6	Acoustic Noise	
6.3.1.7	Crosstalk	
<b>System Physical Requirements</b>		
6.3.2.2	Electrical Requirements	<i>Rubio</i>
6.3.2.3	Uninterruptable Power Supply	
6.3.2.4	Multiple Lines/Workstation Requirement	
6.3.2.5	CPE Expansion Requirement	
6.3.2.6	Printing Capability at Local PSAP	
<b>Intelligent Workstation Physical Requirements</b>		
6.3.3.1	IWS Hardware Requirements	<i>Rubio</i>
6.3.3.2	User Volume Controls	
6.3.3.3	Standard Keyboard	
6.3.3.4	Mouse	
6.3.3.5	Keyboard Arbitrator	
6.3.3.6	Monitor	
6.3.3.7	Auxiliary Keypad Dialer	
6.3.3.8	Headset/Handset Capability	
6.3.3.9	Radio Dispatch Integration	
6.3.3.10	IWS Wiring	
6.3.3.11	IWS Logging Recorder Interface	
<b>Interconnectivity</b>		
6.3.4.1	System Connections	<i>Rubio</i>
6.3.4.2	Wireless Connections	
6.3.4.3	ALI Retrieval	
6.3.4.4	Cabling	
6.3.4.5	CPE Interface to Existing Equipment	
6.3.4.6	Remote Data Transfer Interface	
6.3.4.7	Additional LCD/LED Monitor Interface	
6.3.4.8	Trunk and Line Interfaces	
6.3.4.9	Logging Recorder Interface	

6.3.4.10	IWS Based Logging Interface	<i>Refer</i>
6.3.4.11	Local Maintenance Terminal Interface	
6.3.4.12	Interoperability with GIS Mapping System	
6.3.4.13	CAD and Mapping Interface	

<b>System Features</b>		
------------------------	--	--

6.4.1.1	ALI Controller	<i>Refer</i>
6.4.1.2	ANI/ALI Display	
6.4.1.3	Dynamic ANI/ALI Output	
6.4.1.4	ALI Error Reporting	
6.4.1.5	Abandoned Call Detail	
6.4.1.6	Internal Time Synchronization	
6.4.1.7	External Source Time Synchronization	
6.4.1.8	Caller Identification	
6.4.1.9	Wireless ALI- FCC 94-102-Phase I/Phase II One-button Call-back	
6.4.1.10	Voice over Internet Protocol (VoIP) Capability	
6.4.1.11	Complete Call Progress Detection	
6.4.1.12	TDD/TTY	
6.4.1.13	Multi-Media Requests for Assistance	
6.4.1.14	Remote Maintenance Access	
6.4.1.15	System Database Backup	

<b>Call and System Detail Records</b>		
---------------------------------------	--	--

6.4.2.1	Call Detail Record (CDR) Format	<i>Refer</i>
6.4.2.2	Remote CDR Collection Service	
6.4.2.3	System Detail Records	
6.4.2.4	CDR and Quality of Service (QOS)	

<b>Turn-Key System Functionality</b>		
--------------------------------------	--	--

6.4.3.1	Controller Functionality	<i>Refer</i>
6.4.3.2	Redundant Architecture	
6.4.3.3	Call-Path Associated Signaling (CAS) and Non Call-Path Signaling (NCAS)	
6.4.3.4	Administrative Line Support	
6.4.3.5	ALI Caching	
6.4.3.6	System Call Format Flexibility	
6.4.3.7	9-1-1 Emergency Star (*) Codes Transfers	
6.4.3.8	Selective Transfer	
6.4.3.9	Abandoned Call Information	
6.4.3.10	Automatic CDR	

<b>Telecommunicator Call-Taking Functionality</b>		
---	--	--

6.4.4.1 (1)	Hold	<i>Refer</i>
6.4.4.1 (2)	Dial	
6.4.4.1 (3)	Re-dial	
6.4.4.1 (4)	Release	
6.4.4.1 (5)	Transfer	
6.4.4.1 (6)	Conference	
6.4.4.1 (7)	Speed Dial	
6.4.4.1 (8)	ALI Request	
6.4.4.1 (9)	ANI/ALI display (separate display is allowed)	
6.4.4.1 (10)	Four (4) line appearances or more	
6.4.4.1 (11)	Ten (10) multi-function programmable keys or more, programmed as telephone line appearance or a feature of the telephone set	

6.4.4.1 (12)	Headset/handset interface	
6.4.4.1 (13)	Volume control for inbound audio signal for headset/handset	
6.4.4.1 (14)	Volume control for outbound signal and sidetone for headset/handset	
6.4.4.1 (15)	Volume Control for the ringer	
6.4.4.1 (16)	Call status indication (ringing, answered or both)	
6.4.4.2	Flash Transfer	
6.4.4.3	Conferencing Functionality	
6.4.4.4	Distinctive Ringing	
6.4.4.5	Call Queuing	
6.4.4.6	Last Stored Number Redial	
6.4.4.7	Pre-Arrival ALI	
6.4.4.8	Incoming 9-1-1 Emergency Call Display	
<b>Speed-Dial Functionalities</b>		
6.4.5.1	Speed Dial	
6.4.5.2	Speed-Dial Contacts	
6.4.5.3	Speed-Dial Icons	
6.4.5.4	Speed-Dial Shortcut Star (*) Codes	
<b>Additional Functionality</b>		
6.4.6.1	Voice Transfer	
6.4.6.2	Ring Volume	
6.4.6.3	Transmit Mute	
6.4.6.4	Release	
6.4.6.5	Radio System Interface	
<b>Integrated Recall Recording</b>		
6.4.7.1	Integrated Voice Recording (IVR)	
6.4.7.2	Integrated Recall Recording (IRR)	
6.4.7.3	IRR – Management of Old Recordings	
6.4.7.4	IRR – Call Type/Text Information	
6.4.7.5	IRR – Separate Recording and Playback	
6.4.7.6	IRR – Controls	
6.4.7.7	IRR – Speakers	
6.4.7.8	IRR – Radio Channel Recording	
<b>Intelligent Work Station Telephone (IWS) Functionality (Verify on each IWS)</b>		
6.4.8	TDD/TTY Capability	
6.4.9	Call/Line Indicators	
6.4.10	System Sounds and Icons	
6.4.11	Graphical User Interface (GUI)	
6.4.12	Help Documents	
6.4.13	Screen Layout - Lock	
6.4.14	Screen Layout - Restore	
6.4.15	Printing Capabilities	
6.4.16	Status Window	
6.4.17	Automatic Number Identification (ANI)	
6.4.18	Automatic Location Identification (ALI)	
6.4.19	Call Review	
6.4.20	Instant Messaging (IM)	
6.4.21	ALI Rebid	
6.4.22	ALI Parsing	
6.4.23	Conferencing Capabilities	
6.4.24	Call-back	

6.4.25	Hold	<i>R. Nakamura</i>
6.4.26	Forced Disconnect	
6.4.27	Audio Monitoring	
6.4.28	Barge In	
6.4.29	Make Busy	
6.4.30	Computer Telephony Integration Software Requirements	
6.4.31	Telecommunicator Log-on Roles and Permissions	

Minor Discrepancies:

---



---

Tracking #: 18703 \_\_\_\_\_

Approved TD-288 Amount: \$ 196,716.43

As the authorized representative of:

**Arcadia Police Dept.**

\_\_\_\_\_ (PSAP name),

*I hereby acknowledge receipt, installation and satisfactory performance of the service and/or equipment. If minor discrepancies exist, but do not keep the equipment from performing in accordance with the contracted terms and conditions, these discrepancies are noted above.*

AUTHORIZED BY:

*R. Nakamura*

Signature

*12/6/2018*

Date

*ROY NAKAMURA*

Printed/Typed Name

*LIEUTENANT*

Title

**IMMEDIATELY AFTER ACCEPTANCE:**

Submit the original TD-284, signed by the PSAP authorized representative to the Contractor and submit a copy to the CA 9-1-1 Division

State of California, California 9-1-1 Emergency Communications Office (9-1-1 Office)

COMMITMENT TO FUND 9-1-1 EQUIPMENT AND SERVICES

TD-288 (Rev. 12/06)

**This Form To Be Completed By The State 9-1-1 Office Only**

<b>Public Agency:</b> Arcadia Police Department	<b>Contractor Name:</b> AT&T
<b>Address:</b> 250 W. Huntington Dr.	<b>Mailing Address:</b> 8925 Orangethorpe Ave. #147
<b>City, State, Zip:</b> Arcadia, CA 91007	<b>City, State, Zip:</b> Buena Park, CA 90621
<b>PSAP Manager:</b> Lt. Roy Nakamura	<b>Representative:</b> Henry Wang
<b>E-mail Address:</b> <a href="mailto:rnakamura@ci.arcadia.ca.us">rnakamura@ci.arcadia.ca.us</a>	<b>E-Mail Address:</b>
<b>Phone Number:</b> 626-574-5183	<b>Phone Number:</b>
<b>Fax Number:</b> 626-447-6581	<b>Fax Number:</b>

**Type of Funding Request:**

- ( X ) 9-1-1 Equipment                      ( ) 9-1-1 Network                      ( ) Ali Retrieval Circuit  
 ( ) 9-1-1 Education                      ( ) Alternate Answer                      ( ) 7-Digit Phone Lines  
 ( ) 9-1-1 Trunks                      Other:



**Description of Equipment and Services to be funded:** AT&T will install and maintain one new 4 position Viper 9-1-1 System for Arcadia PD. CPE system will be installed and maintained exclusive to the terms and conditions of MPA contract 5-12-58-01.

**Purchase/Service Information:** Include equipment or service description, quantity, part number, unit cost, installation cost, monthly cost, tax and total cost. Attach contractors quote or PSAP purchase order, where applicable.

Description	Quantity	Service/ Eqmt. ID#	Unit Cost	Installation	Monthly Cost	Total Recurring Cost	Total Non-Recurring Cost
Viper 9-1-1 CPE	1		113,635.30			-	113,635.30
Maintenance	48				716.25	34,380.00	
Installation	1			34,939.39		-	34,939.39
Training	1		6,312.50			-	6,312.50
						-	-
						-	-
						-	-
						-	-
						-	-
						-	-
<b>Subtotal</b>						34,380.00	154,887.19
<b>Tax and Surcharge</b>							7,449.24
<b>TOTAL APPROVED</b>							<b>\$196,716.43</b>

TD-288 expiration date: N/A                      Fiscal Year: 2016/2017  
 All invoices shall refer to tracking number: 18703                      PSAP/Object Code: 1902/702.08

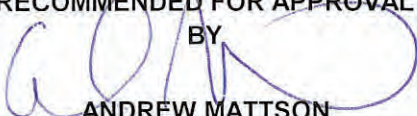
*The State of California's monetary obligation under this agreement in subsequent fiscal years is subject to, and contingent upon, availability of funds in the State Emergency Telephone Account. Please be advised that this commitment to fund does not constitute a binding purchase order agreement.*

<b>RECOMMENDED FOR APPROVAL</b>	<b>Telephone Number</b>	<b>APPROVED BY</b>	<b>Date</b>
BY  ANDREW MATTSON	916-657-9459	 ALICIA FULLER	11/8/14

State of California, California 9-1-1 Emergency Communications Office (9-1-1 Office)  
**COMMITMENT TO FUND 9-1-1 EQUIPMENT AND SERVICES**

TD-288 (Rev. 12/06)

**This Form To Be Completed By The State 9-1-1 Office Only**

<b>Public Agency:</b> Arcadia Police Department	<b>Contractor Name:</b> AT&T
<b>Address:</b> 250 W. Huntington Dr.	<b>Mailing Address:</b> 8925 Orangethorpe Ave. #147
<b>City, State, Zip:</b> Arcadia, CA 91007	<b>City, State, Zip:</b> Buena Park, CA 90621
<b>PSAP Manager:</b> Lt. Roy Nakamura	<b>Representative:</b> Henry Wang
<b>E-mail Address:</b> <a href="mailto:rnakamura@ci.arcadia.ca.us">rnakamura@ci.arcadia.ca.us</a>	<b>E-Mail Address:</b>
<b>Phone Number:</b> 626-574-5183	<b>Phone Number:</b>
<b>Fax Number:</b> 626-447-6581	<b>Fax Number:</b>

**Type of Funding Request:**

- 9-1-1 Equipment                       9-1-1 Network                       Ali Retrieval Circuit  
 9-1-1 Education                       Alternate Answer                       7-Digit Phone Lines  
 9-1-1 Trunks                      Other: CPE Maintenance



**Description of Equipment and Services to be funded:** AT&T will provide year 6 and 7 maintenance on the 4 position Viper 9-1-1 System at Arcadia PD. Purchase to be governed by the terms and conditions of MPA contract 5-12-58-01.

**Purchase/Service Information:** Include equipment or service description, quantity, part number, unit cost, installation cost, monthly cost, tax and total cost. Attach contractors quote or PSAP purchase order, where applicable.

Description	Quantity	Service/ Eqmt. ID#	Unit Cost	Installation	Monthly Cost	Total Recurring Cost	Total Non-Recurring Cost
Year 6 Maintenance	12				1,310.14	15,721.68	-
Year 7 Maintenance	12				1,385.22	16,622.64	-
						-	-
						-	-
						-	-
						-	-
						-	-
						-	-
						-	-
						-	-
<b>Subtotal</b>						32,344.32	-
<b>Tax and Surcharge</b>							
<b>TOTAL APPROVED</b>						<b>\$32,344.32</b>	

TD-288 expiration date: N/A                      Fiscal Year: 2022/2023  
 All invoices shall refer to tracking number: 20144                      PSAP/Object Code: 1902/702.14

*The State of California's monetary obligation under this agreement in subsequent fiscal years is subject to, and contingent upon, availability of funds in the State Emergency Telephone Account. Please be advised that this commitment to fund does not constitute a binding purchase order agreement.*

RECOMMENDED FOR APPROVAL BY  ANDREW MATTSON	Telephone Number 916-657-9459	APPROVED BY  ALICIA FULLER	Date 12/12/16
---	----------------------------------	--	------------------



DATE **11/16/2016**  
 VERSION **1.0**  
 Account Manager Henry Wang  
 Phone 714-680-5789  
 Email [hw3126@att.com](mailto:hw3126@att.com)

**Year 6 and 7 Maintenance Quote Summary**  
**Arcadia Police Department**  
**Standalone Configuration**

West  
 911 CPE Year 6 and 7 Maintenance  
 (4) VIPER/Power911 Positions

	911 CPE	
Monthly Maintenance Price for Year 6:	\$	1,310.14
TOTAL:	\$	1,310.14
<b>SUB-TOTAL FOR YEAR 6 (\$1,310.14 x 12):</b>	<b>\$</b>	<b>15,721.68</b>
Monthly Maintenance Price for Year 7:	\$	1,385.22
TOTAL:	\$	1,385.22
<b>SUB-TOTAL FOR YEAR 7 (1,385.22 x 12):</b>	<b>\$</b>	<b>16,622.64</b>
<b>GRAND TOTAL FOR YEAR 6 AND YEAR 7:</b>	<b>\$</b>	<b>32,344.32</b>

Quote Valid For 120 Days

\* This year 6 and year 7 maintenance is for: (4) VIPER/Power911 positions.

*#20144*

6.4.25	Hold	<i>Rubach</i>
6.4.26	Forced Disconnect	
6.4.27	Audio Monitoring	
6.4.28	Barge In	
6.4.29	Make Busy	
6.4.30	Computer Telephony Integration Software Requirements	
6.4.31	Telecommunicator Log-on Roles and Permissions	

Minor Discrepancies:

---



---

Tracking #: 18703 \_\_\_\_\_

Approved TD-288 Amount: \$ 196,716.43

As the authorized representative of:

**Arcadia Police Dept.**

\_\_\_\_\_ (PSAP name),

*I hereby acknowledge receipt, installation and satisfactory performance of the service and/or equipment. If minor discrepancies exist, but do not keep the equipment from performing in accordance with the contracted terms and conditions, these discrepancies are noted above.*

AUTHORIZED BY:

*R Nakamura*  
 \_\_\_\_\_  
 Signature

*12/16/2018*  
 \_\_\_\_\_  
 Date

*Ray Nakamura*  
 \_\_\_\_\_  
 Printed/Typed Name

*LIEUTENANT*  
 \_\_\_\_\_  
 Title

**IMMEDIATELY AFTER ACCEPTANCE:**

Submit the original TD-284, signed by the PSAP authorized representative to the Contractor and submit a copy to the CA 9-1-1 Division

**State of California**  
**California 9-1-1 Emergency Communications Division**  
**STAND ALONE CPE SYSTEM ACCEPTANCE AND AUTHORIZATION FORM**  
 TD-284 (Rev. 3/2017)

This document shall be used by the PSAP to validate that the purchased 9-1-1 system (equipment, software and all functionality) is acceptable.

All verification is to be completed by the PSAP authorized representative. Each item should be validated against the referenced MPA IFB Requirement. The MPA IFB Requirements can be downloaded from the CA 9-1-1 Division website at:

<http://www.caloes.ca.gov/cal-oes-divisions/public-safety-communications/ca-9-1-1-emergencycommunications-branch/ca-9-1-1-services-contracts>

MPA RFP Requirement Number	Requirement	PSAP Initial
<b>Audio</b>		
6.3.1.5	Audio Quality	<i>R. Lopez</i>
6.3.1.6	Acoustic Noise	
6.3.1.7	Crosstalk	
<b>System Physical Requirements</b>		
6.3.2.2	Electrical Requirements	<i>R. Lopez</i>
6.3.2.3	Uninterruptable Power Supply	
6.3.2.4	Multiple Lines/Workstation Requirement	
6.3.2.5	CPE Expansion Requirement	
6.3.2.6	Printing Capability at Local PSAP	
<b>Intelligent Workstation Physical Requirements</b>		
6.3.3.1	IWS Hardware Requirements	<i>R. Lopez</i>
6.3.3.2	User Volume Controls	
6.3.3.3	Standard Keyboard	
6.3.3.4	Mouse	
6.3.3.5	Keyboard Arbitrator	
6.3.3.6	Monitor	
6.3.3.7	Auxiliary Keypad Dialer	
6.3.3.8	Headset/Handset Capability	
6.3.3.9	Radio Dispatch Integration	
6.3.3.10	IWS Wiring	
6.3.3.11	IWS Logging Recorder Interface	
<b>Interconnectivity</b>		
6.3.4.1	System Connections	<i>R. Lopez</i>
6.3.4.2	Wireless Connections	
6.3.4.3	ALI Retrieval	
6.3.4.4	Cabling	
6.3.4.5	CPE Interface to Existing Equipment	
6.3.4.6	Remote Data Transfer Interface	
6.3.4.7	Additional LCD/LED Monitor Interface	
6.3.4.8	Trunk and Line Interfaces	
6.3.4.9	Logging Recorder Interface	

6.3.4.10	IWS Based Logging Interface
6.3.4.11	Local Maintenance Terminal Interface
6.3.4.12	Interoperability with GIS Mapping System
6.3.4.13	CAD and Mapping Interface

*Reviewed*

#### System Features

6.4.1.1	ALI Controller
6.4.1.2	ANI/ALI Display
6.4.1.3	Dynamic ANI/ALI Output
6.4.1.4	ALI Error Reporting
6.4.1.5	Abandoned Call Detail
6.4.1.6	Internal Time Synchronization
6.4.1.7	External Source Time Synchronization
6.4.1.8	Caller Identification
6.4.1.9	Wireless ALI- FCC 94-102-Phase I/Phase II One-button Call-back
6.4.1.10	Voice over Internet Protocol (VoIP) Capability
6.4.1.11	Complete Call Progress Detection
6.4.1.12	TDD/TTY
6.4.1.13	Multi-Media Requests for Assistance
6.4.1.14	Remote Maintenance Access
6.4.1.15	System Database Backup

*Reviewed*

#### Call and System Detail Records

6.4.2.1	Call Detail Record (CDR) Format
6.4.2.2	Remote CDR Collection Service
6.4.2.3	System Detail Records
6.4.2.4	CDR and Quality of Service (QOS)

*Reviewed*

#### Turn-Key System Functionality

6.4.3.1	Controller Functionality
6.4.3.2	Redundant Architecture
6.4.3.3	Call-Path Associated Signaling (CAS) and Non Call-Path Signaling (NCAS)
6.4.3.4	Administrative Line Support
6.4.3.5	ALI Caching
6.4.3.6	System Call Format Flexibility
6.4.3.7	9-1-1 Emergency Star (*) Codes Transfers
6.4.3.8	Selective Transfer
6.4.3.9	Abandoned Call Information
6.4.3.10	Automatic CDR

*Reviewed*

#### Telecommunicator Call-Taking Functionality

6.4.4.1 (1)	Hold
6.4.4.1 (2)	Dial
6.4.4.1 (3)	Re-dial
6.4.4.1 (4)	Release
6.4.4.1 (5)	Transfer
6.4.4.1 (6)	Conference
6.4.4.1 (7)	Speed Dial
6.4.4.1 (8)	ALI Request
6.4.4.1 (9)	ANI/ALI display (separate display is allowed)
6.4.4.1 (10)	Four (4) line appearances or more
6.4.4.1 (11)	Ten (10) multi-function programmable keys or more, programmed as telephone line appearance or a feature of the telephone set

*Reviewed*

6.4.4.1 (12)	Headset/handset interface	
6.4.4.1 (13)	Volume control for inbound audio signal for headset/handset	
6.4.4.1 (14)	Volume control for outbound signal and sidetone for headset/handset	
6.4.4.1 (15)	Volume Control for the ringer	
6.4.4.1 (16)	Call status indication (ringing, answered or both)	
6.4.4.2	Flash Transfer	
6.4.4.3	Conferencing Functionality	
6.4.4.4	Distinctive Ringing	
6.4.4.5	Call Queuing	
6.4.4.6	Last Stored Number Redial	
6.4.4.7	Pre-Arrival ALI	
6.4.4.8	Incoming 9-1-1 Emergency Call Display	
<b>Speed-Dial Functionalities</b>		
6.4.5.1	Speed Dial	
6.4.5.2	Speed-Dial Contacts	
6.4.5.3	Speed-Dial Icons	
6.4.5.4	Speed-Dial Shortcut Star (*) Codes	
<b>Additional Functionality</b>		
6.4.6.1	Voice Transfer	
6.4.6.2	Ring Volume	
6.4.6.3	Transmit Mute	
6.4.6.4	Release	
6.4.6.5	Radio System Interface	
<b>Integrated Recall Recording</b>		
6.4.7.1	Integrated Voice Recording (IVR)	
6.4.7.2	Integrated Recall Recording (IRR)	
6.4.7.3	IRR – Management of Old Recordings	
6.4.7.4	IRR – Call Type/Text Information	
6.4.7.5	IRR – Separate Recording and Playback	
6.4.7.6	IRR – Controls	
6.4.7.7	IRR – Speakers	
6.4.7.8	IRR – Radio Channel Recording	
<b>Intelligent Work Station Telephone (IWS) Functionality (Verify on each IWS)</b>		
6.4.8	TDD/TTY Capability	
6.4.9	Call/Line Indicators	
6.4.10	System Sounds and Icons	
6.4.11	Graphical User Interface (GUI)	
6.4.12	Help Documents	
6.4.13	Screen Layout - Lock	
6.4.14	Screen Layout - Restore	
6.4.15	Printing Capabilities	
6.4.16	Status Window	
6.4.17	Automatic Number Identification (ANI)	
6.4.18	Automatic Location Identification (ALI)	
6.4.19	Call Review	
6.4.20	Instant Messaging (IM)	
6.4.21	ALI Rebid	
6.4.22	ALI Parsing	
6.4.23	Conferencing Capabilities	
6.4.24	Call-back	

*Revised*

*Revised*

*Revised*

*Revised*

*Revised*



Arcadia Police Department

With



SCOPE OF WORK

For  
Power 911 / VIPER  
NetClock  
Project

## Table of Contents

<b>1.0</b>	<b>OVERVIEW .....</b>	<b>1</b>
1.1	PURPOSE & OBJECTIVES.....	1
1.2	REUTILIZATION OF EXISTING EQUIPMENT .....	2
1.3	EQUIPMENT REMOVAL & DISPOSAL.....	2
<b>2.0</b>	<b>DESIGN SOLUTION.....</b>	<b>2</b>
2.1	CALL PROCESSING.....	2
2.2	BACKROOM SYSTEM .....	4
2.3	SYSTEM GROWTH CAPABILITIES .....	5
2.4	CONNECTIVITY.....	5
2.5	SYSTEM PROGRAMMING .....	6
2.6	INTEGRATION REQUIREMENTS.....	6
<b>3.0</b>	<b>CHANGE REQUESTS.....</b>	<b>6</b>
<b>4.0</b>	<b>ACCEPTANCE TESTING .....</b>	<b>7</b>
<b>5.0</b>	<b>RESPONSIBILITIES.....</b>	<b>8</b>
5.1	AT&T PROJECT TEAM .....	8
5.2	PROJECT MANAGER.....	8
5.3	AT&T RESPONSIBILITIES .....	8
5.4	ARCADIA PD RESPONSIBILITIES.....	9
<b>6.0</b>	<b>INSTALLATION SCHEDULE .....</b>	<b>9</b>
<b>7.0</b>	<b>MAINTENANCE PLAN.....</b>	<b>10</b>
7.1	MAINTENANCE AND REMOTE ACCESS SERVICES CAPABILITIES .....	10
7.2	POST-INSTALLATION SUPPORT LIMITATIONS.....	11
7.3	REPAIR OF UNSUPPORTED FAILURES .....	11
<b>8.0</b>	<b>TRAINING .....</b>	<b>12</b>
8.1	SUPERVISOR/DISPATCHER TRAINING.....	12
8.2	TRAINING DOCUMENTATION .....	12
8.3	SERVICE MANUAL DOCUMENTATION.....	12
<b>9.0</b>	<b>DOCUMENT ACCEPTANCE .....</b>	<b>13</b>
<b>APPENDIX A: AGENCY COMPLIANCE - SITE CERTIFICATION DOCUMENT .....</b>		<b>14</b>
<b>APPENDIX B: LAN/WAN POLICY .....</b>		<b>15</b>
<b>APPENDIX C: DISPATCH AND EQUIPMENT FLOOR PLANS.....</b>		<b>16</b>
<b>APPENDIX D: PRICING &amp; TERMS.....</b>		<b>18</b>
<b>APPENDIX E: CHANGE ORDER REQUEST FORM.....</b>		<b>19</b>
<b>APPENDIX F: MAINTENANCE PROCEDURES .....</b>		<b>20</b>

## 1.0 OVERVIEW

### 1.1 Purpose & Objectives

The purpose of this document is to describe the work to be performed by AT&T California (herein referred to as Contractor) in satisfying the E9-1-1 system requirements for Arcadia PD (herein referred to as Agency). In order to achieve the proposed system design the following system work operations are required: replace existing West (formerly known as "Intrado") Power 911/VIPER system with new Power911/VIPER system (new hardware, current software versions, etc.). The aforementioned equipment will be used to terminate various trunks, lines and data circuits required to process E9-1-1, and administration calls by the Agency.

**AT&T will provide the following products:**

#### **West Call Processing Equipment**

<b>Qty</b>	<b>Power 911/VIPER</b>
1	VIPER Cabinet (7')
1	VIPER Core Servers (4) & Software (OS, SQL, etc.)
1	Power 911 Server
2	CAMA Interface Module (4 trunks per module)
2	AIM Modules (4 lines per module)
4	VIPER Gateway Shelf
2	-48V Power Supply & Shelf for VIPER system
2	24 Port Ethernet Switch
4	Power 911 Intelligent Workstations (includes CPU, VIPER backroom interface components, Audio Interface equipment, keyboard, and mouse).
4	Integrated Telephony & Radio Recorder (ITRR)
4	22" Flat panel widescreen monitor w/ built-in speakers
4	Genovation 24 button keypad
4	Position UPS
2	Backroom UPS

#### **Data Management Equipment**

<b>Qty</b>	<b>NetClock System</b>
1	9483 MasterClock with (4 Ethernet ports)
1	GPS antenna, antenna cable, antenna surge protector

**Agency will supply following system components:**

<b>Qty</b>	<b>Item Description</b>
-	Conduit to roof for NetClock antenna

**System components NOT included in the sale:**

<b>Item Description</b>
CDR Printer / ePrinter

IP Admin Phones
Power MIS / Power ECaTS
Power Map / MapFlex / AVL Interface
Long-term Voice Recorder (LVR)
Power Radio Upgrade

**\*\*Please refer to Line Item price list for all parts in Appendix D.\*\***

***The equipment provided by ATT will comply with State of California Contract 5-12-58-01 AT&T CALIFORNIA and any FCC requirements for E9-1-1. It will also meet the NENA requirements for displaying ANI/ALI Phase II wireless calls.***

### **1.2 Reutilization of Existing Equipment**

The following equipment has been certified to be compatible with current technology and in good condition. This equipment will be reutilized:

<b>Qty</b>	<b>Item Description</b>
4	Existing backroom to workstation wiring

Re-utilization of existing equipment may require additional system down time that results in the Agency going to Alternate Answer.

\*Note: Any IWS workstation that can be re-used for peripheral purposes will be evaluated for use. All workstations must meet minimum vendor specifications to be re-used.

### **1.3 Equipment Removal & Disposal**

#### **West Equipment**

The following equipment will be left at the Agency's building by AT&T:

- ◆ VIPER & Power 911 servers, workstations and ancillary components
- ◆ Miscellaneous VIPER components not being re-used

In the event the old equipment must be removed, AT&T technicians will work with the Agency's personnel to remove the above equipment. AT&T technicians will place old equipment in an area designated by the Agency. AT&T technicians will not remove any existing equipment from Arcadia PD's building.

## **2.0 DESIGN SOLUTION**

### **2.1 Call processing**

#### **System Overview**

AT&T will provide a complete E9-1-1 system solution from a high-level perspective by deploying Call-Processing, and Data-Management related system equipment. The functionality of these system components when coupled together enables the Agency with the capability to process E9-1-1 and administrative type calls and other various PSAP emergency and non-emergency functions. While also creating a system solution that enables the Agency to gather, process, and statistically report all critical 911/administrative call information.

Arcadia PD currently has Power 911 integrated with Power Radio hardware and software; both of which are being maintained and supported by AT&T. After the upgrade to VIPER, the old Power 911/Radio workstations may continue to be used for the Agency's radio functionality (AT&T will no longer maintain or support these workstations, hardware, or software). Unfortunately, integration of Power Radio with the new Power 911/VIPER system is not supported.

AT&T will implement West's Call-Procession suite of hardware/software application(s): Power 911/VIPER for this E9-1-1 system design solution. AT&T will achieve these system objectives by implementing the following managed work operations:

### **Call-Taker/Radio Positions in Dispatch Area**

Install four (4) workstations (positions 1-4) with: Power 911 and ITRR. These positions are AT&T provided workstations. Each workstation includes: a 24-button Genovation keypad, (1) 22" flat panel widescreen monitor, keyboard, mouse, SONIC box, and a single handset jack (telephony only) configured as a call-taking / dispatching position(s).

The existing wiring to each position will be reused barring the new furniture layout is able to accommodate the existing cabling. The existing cabling is: four CAT5e cables to each position from the backroom. The CAT5e cable is provisioned as follows: (1) Power 911 Primary NIC, (1) Power 911 Secondary NIC, (1) for LTR position-based recording, and (1) for future/spare.

The Agency has communicated their intent to source new furniture and coordinate the installation of the new furniture with the Power 911 upgrade. To accommodate this effort, AT&T will move the existing positions (Power911 and Power Radio) to the EOC room while the new furniture is installed; the new 911 system will be installed in the furniture for testing and go-live. The Power Radio positions will be installed in the new furniture at the applicable time in the project timeline. Should the furniture upgrade occur after the 911 upgrade; additional labor rates may apply to uninstall/re-install the positions.

### **ITRR**

Integrated Telephony and Radio Recorder (ITRR) is a short-term recorder and is used to record both telephony audio (from Power 911) and radio audio (from radio console) so it can be played back as desired by the user. It is configured for an eight hour continuous first-in, first out method. Playback output is done via external speakers only at this time (cannot be played via head/handset).

### **Audio Interface**

In order to ensure proper audio functionality at each IWS position and facilitate audio connectivity with third party audio devices at the Agency location, the system design includes a SONIC Box that hands off telephony audio (from Power 911) to a radio console. The SONIC Box also provides a two wire audio path of position audio that will be terminated to AT&T provide long-term voice recorder. The demarcation point for this audio will be located in the backroom. This enables the radio console to provide headset sharing between phone and radio. The radio console will perform the audio arbitration/switching thus the radio headset jackbox would provide both telephony and radio audio.

Only West tested and certified headsets and amplifiers (as per the List of Approved Headsets, revision 48, Document) are supported. Any non-approved headset or amplifier will be supported on a “best effort” basis.

## **2.2 Backroom System**

### **System Overview**

911 CAMA trunks originating from the Agency’s serving central office tandem will be terminated on the VIPER system (via CAMA Interface Modules) controller equipment located in the backroom. Analog lines such as 10-digit emergency, 10-digit admin lines, and ring-down lines will be terminated on the VIPER (via AIM modules) call processing equipment also located in the backroom. The AIM modules are also known as admin gateway, in that it processes voice and data (Caller-ID) type calls using FXO signaling along with supporting standard FSK format Caller-ID decoding. Digital trunk(s) are not a part of this solution. Please refer to the Trunks & Lines table below for a full list of lines that are a part of this design.

### **VIPER**

Install VIPER hardware in one cabinet located in Telco equipment backroom. It should be noted that the VIPER equipment will be installed in a pre-racked cabinet therefore a new cabinet will replace the existing VIPER cabinet (dimensions will be similar to existing). The VIPER equipment cabinet must be able to fit in all areas leading to the Telco equipment room. The new system will need to be installed in parallel to the existing production system until cut over to the new system is applicable. As such, temporary backroom installation arrangements will need to be made in order to minimize disruption to the existing system and operations.

### **NetClock**

AT&T will install a new Spectracom GPS NetClock system (9000 series) in the backroom with the VIPER system.

AT&T will install a GPS Antenna on the Agency's roof. The Agency will provide a minimum of one inch (1") in diameter conduit from backroom where the NetClock is to be installed to the roof (for antenna cabling) and ensure that a clearance of approximately 10 feet (10') in diameter exists for the GPS antenna.

AT&T will provide the installation configuration services related to the NetClock system. The MasterClock (9483) has (4) integrated Ethernet Time Servers. One of these ports will be connected to the AT&T E911 system equipment (VIPER local area network (LAN)) and configured with an IP address that corresponds to the VIPER IP schema. The remaining three ports (these ports are hardware isolated) may be used for Agency networks (will need to provide IP address and wiring to the port(s) on the device).

AT&T will install one (1) new Spectracom TimeView display clock. The location will be determined by Agency prior to installation. This display clock requires local electrical power (NEMA 5-15/20R) where the display clock will be mounted. The Agency will provide a minimum of one inch (1”) in diameter conduit, or other cable pathway, extending from the equipment room where the AT&T provided NetClock equipment is installed, to the room where the TimeView Display Clock will be located.

## ALI

The existing network geographic diverse 56K Data circuit (DS0) that carry the Automatic Location Identification (ALI) data will terminate in the AT&T provided router, which is connected via RS-232C cables to the VIPER servers.

## CAD

AT&T will provide an interface connection demarcation point between the VIPER server and Agency provided Computer Aided Dispatch (CAD) computer system via a RS-232C cable located in the backroom. If the data rate of this RS232C connection is set for 9600 bps there is a 50ft limitation imposed on this connection. This 50 foot limitation can be increased with the use of an Agency provided RS232c extender. AT&T can provide a quote to the Agency to provide this RS232c extender to overcome the 50 foot distance limitation of the CAD to AT&T backroom.

## Firewall

The VIPER system includes a firewall to give remote access to AT&T for support and maintenance. A broadband (DSL or higher) connection or interface to the Agency's network to the AT&T firewall is required and to be provided by the Agency as per the terms of the State contract. Specifications for these options are provided on separate documents. An interface to the Agency's network will allow for access to Analytics reports from Agency workstations. AT&T will work with the Agency to coordinate this effort.

## 2.3 System Growth Capabilities

AT&T warrants that the hardware, software and operating systems sold are current at the time of shipment. Software and hardware manufacturers continually upgrade their products. This may require the Agency to upgrade hardware, software or operating systems in the future in order to expand this system. The maintenance package included in this sale does not include software/hardware upgrades required for expansion or integration.

The modular design of VIPER allows the system to be configured to accommodate up to (192) - E9-1-1 Positions, (192) - incoming 911 trunks, and (192) – analog lines (supports Caller-ID).

Arcadia PD's system will be configured with a capacity of (8) 911 CAMA trunks, currently using (5), leaving a future growth of (3) 911 CAMA trunks. This system is also configured with a capacity of (8) analog lines, currently using (5) leaving a future growth of (3) lines. The number of modules in this system was based upon the needs and requirements of the Agency at time of system design. Additional equipment cards and/or hardware may be added to the system to increase lines or positions.

## 2.4 Connectivity

### Trunks & Lines

Qty	Trunk Line Definition
5	E9-1-1 CAMA Trunks
4	Emergency Lines (as inventoried below)
	<ul style="list-style-type: none"><li>• 574-5121</li><li>• 574-5122</li><li>• 574-5123</li><li>• 574-5124</li></ul>

1	Ringdown Line (as inventoried below)
	<ul style="list-style-type: none"> <li>• Verdugo</li> </ul>

## 2.5 System Programming

The system will be programmed with a log in ID for each Administrator/Supervisor. The administrators/ Supervisors will have all the capabilities that the dispatchers have as well as additional capabilities requested by the *Agency*. The “master” speed dial list will be the same for each position and the site supervisor/administrator will have the capability to change, add, and delete speed dials on the “master” list.

The system will be programmed with a log in ID for each dispatcher. There will be a single Agent Profile for all dispatchers that will have the same configuration, colors and icons.

The system programming requirements may be changed at the request of the *Agency* during the Installation process. The AT&T Project Manager will work with the *Agency* to meet the *Agency*’s specific needs.

All system programming on Power 911 will be handled by AT&T. All initial system programming will be to replicate the current operation of Arcadia PD as closely as possible. If it is determined during design sessions that changes need to be made, they can be made at that time. Once the system is cutover and accepted, any further adds, moves, and changes will be performed on a Time and Materials basis at the prevailing contract rates. (Examples of adds, moves, and changes are: Adding 7 digit emergency lines to the system; moving a Power 911 position to another location; changing the DID number on a position).

## 2.6 Integration Requirements

AT&T will be the integrator for all telephony-related issues. AT&T will be responsible for installation and maintenance of all network facilities terminating into the connector block installed at each position.

### CAD Interface

The Power 911 E9-1-1 system provides a CAD Interface Port that allows other system devices to interface with emergency call information. It will provide the retrieved ANI/ALI for an emergency call, as well as the answering position identification on an ASCII RS-232C port. The demarcation point for the *Agency* CAD system is the labeled serial port/connector from the VIPER server(s) in the equipment room.

### Building Modifications

All building modifications are the responsibility of the *Agency*. The AT&T Project Manager will work closely with the *Agency* to determine proper timeline coordination for a smooth system implementation. Please refer to Appendix A for the specific modifications to be performed by the *Agency*.

## 3.0 CHANGE REQUESTS

The *Agency* may at any time, by written order, and without notice to the *Contractor's* sureties, submit a change order to the *Contractor*. Within ten (10) working days of receiving a proposed change order, the *Contractor* will submit a written cost estimate, which will include adjustments to the Project Price, Project Schedule, Statement of Work, Acceptance Criteria, or any other obligations of the *Contractor*, as applicable. The *Contractor* or the *Agency* may also decline the change order, depending on the nature of the requested changes.

The *Contractor* may also propose a change order involving additions, deletions, or revisions to the work, or any obligations imposed upon the Parties under this agreement. AT&T's changes to the system design or individual component changes will be submitted to the *Agency* for approval using the Change Request Form shown in Appendix E.

The *Agency* will appoint a single individual as a Project Manager. Change Orders will be approved in writing, by the *Agency's* Project Manager. The *Contractor* will not proceed with any work contemplated in any proposed Change Order until it receives written notification to commence such work from the *Agency's* Project Manager.

#### **4.0 ACCEPTANCE TESTING**

Final system acceptance for this Scope of Work will occur when the standards of performance of the State contract which can be reviewed at:

<http://www.caloes.ca.gov/cal-oes-divisions/public-safety-communications/ca-9-1-1-emergency-communications-branch/ca-9-1-1-services-contracts>

These will have been met after 240 consecutive hours of operation following the cutover date. During these 240 hours, the system will function without interruption, as defined by contract and according to the project specifications. If the 9-1-1 system fails to meet the standards of performance, then the 240 hour system acceptance period will re-start following correction of the problem.

Once the system is accepted, any further adds, moves and changes will be performed on a Time and Materials basis at the prevailing contract rates.

## 5.0 RESPONSIBILITIES

### 5.1 AT&T Project Team

Contacts			
Role	Name	Phone / Fax / Pager	Mail / E-mail
Application Sales Executive	Henry Wang	Phone: (714) 680-5789 Cell: (213) 422-1152	hw3126@att.com 8925 Orangethorpe Ave. Room 153 Buena Park, CA 90621
9-1-1 Service Executive	Don Baca	Cell: (775) 313-2181	db3165@att.com 10550 W Charleston Las Vegas, NV 89135
9-1-1 Manager Special Services	Maria Centeno	Phone: (626) 575-6401	mc2418@att.com 3640 El Monte Ave. El Monte 91731-2526
Technical Sales Consultant II	Robert Russo	Phone: (951) 369-2282 Cell: (951) 500-2130	rr1713@att.com 3580 Orange Street Rm 104 Riverside, CA 92501
Dispatch Manager	Christine Campbell	Phone: (626) 574-5150	ccampbell@ci.arcadia.ca.us 250 W. Huntington Dr. Arcadia, CA. 91006
PSAP Manager	Lt. Roy Nakamura	Phone: (626) 574-5183	rnakamura@ci.arcadia.ca.us 250 W. Huntington Dr. Arcadia, CA. 91006
State 911 Consultant	Andrew Mattson	Phone: (916) 657-9459	Andrew.Mattson@caloes.ca.gov 601 Sequoia Pacific Blvd. MS-911 Sacramento, CA 95814

### 5.2 Project Manager

An AT&T Project Manager will be assigned for this system implementation. The Project Manager is responsible to plan, organize, control, direct and coordinate people and material resources throughout the life of the project.

### 5.3 AT&T Responsibilities

AT&T is responsible for the following:

- Delivery of equipment
- Security of equipment, until equipment is delivered to customer premise.
- Disposal of packaging materials and debris.
- Any damage caused by Contractor (or Contractor's agent) to equipment, building, or other property.
- Installation of common control (server) equipment in racks/cabinets.
- Dressing of all cables.
- Identification and labeling of all cables.
- Installation of appropriate cabling from equipment room to all Power 911 positions.
- NENA standard ANI/ALI interface supplied to the Agency owned CAD system.
- Installation of interface jacks for radio headsets.

## 5.4 Arcadia PD Responsibilities

### Equipment Room

- Provide locked, limited access to the equipment room.
- Provide space for VIPER cabinet as agreed upon and depicted in below drawing
- Adequate space for working area and for spare part/equipment storage (if applicable).
- Furnishing HVAC equipment that will keep the backroom temperature and humidity levels of 72 degrees F +/- 5 and less than 50% relative humidity.
- Provide/verify that each AT&T backroom equipment cabinet has two 20 amp breakered circuits dedicated to the rack with a NEMA 5-20R outlet each and a single dedicated NEMA 5-20R breakered circuit for each rack (if required).
- Earth ground for AT&T provided equipment.

### Dispatch Room

- Furniture selected by *Agency* is compatible with, or will be modified by the *Agency* to be compatible with, the selected system equipment.
- Provide/verify that each AT&T dispatch position has one 15 or 20 amp (NEMA 5-15/20R) breakered circuit dedicated to emergency call-taking with a quad outlet. Ancillary electrical components such as heaters, lights, and furniture will not be on this circuit(s).
- Provide conduit run from each dispatch position to backroom equipment.

### General

- Access to building for AT&T and subcontractors.
- Conduit and coring of walls.
- Adequate power and power outlets and circuit breakers.
- All radio and CAD equipment.
- Adequate security to prevent theft of computer equipment.
- On-going upkeep for room requirements listed.
- Technical expertise from *Agency's* other vendor's during planning, installation and cut-over.
- The *Agency's* Project Manager will facilitate the resolution of any problem determined with these interfaces pertaining to the radio, CAD, recorders, NetClock or other *Agency* owned interfaces.
- Full and free access to the 9-1-1 related equipment to provide service (subject to *Agency's* security regulations)
- Maintain records and documentation associated with contractor performance

Note: The 911 Network and Agency Networks may not share the same LAN Segments. Power 911 IP packets must be segregated from CLETS, NCIC, DMV, CWS, and all other Agency network traffic.

## 6.0 INSTALLATION SCHEDULE

The following table is provided as a *guideline* based on the "Estimated Final Funding Date". The actual funding date will affect the entire timeline.

Estimated Final Funding Date:	<b>10/31/2016</b>
Estimated Equipment Order Date:	<b>11/5/2016</b>
Estimated Equipment Delivery Date:	<b>1/14/2017</b>
Estimated Begin Installation Date:	<b>1/24/2017</b>
Estimated Training Date:	<b>2/7/2017</b>
Programming Change Freeze Date:	<b>2/14/2017</b>
Estimated System Cutover Date:	<b>2/21/2017</b>

The official implementation schedule will be negotiated between the Agency and the AT&T project Manager using the "911 CPE PSAP Implementation Form". Changes to the agreed upon schedule may be made by mutual consent of AT&T and the Ordering Agency and must be documented on the "911 CPE PSAP Implementation Form".

Pricing is based on installation being performed during AT&T's normal business hours (M-F, 8:00am - 5:00pm, excluding AT&T holidays). Installation activities outside of AT&T's normal business hours are available at prevailing after hour tariff. There will be no additional cost to the Agency for an after-hours cutover, if it becomes necessary.

## **7.0 MAINTENANCE PLAN**

### **7.1 Maintenance and Remote Access Services Capabilities**

The 911 system is provisioned to allow AT&T (and West) to remote access into the 911 system in order to identify software and hardware problems and make repairs. In the event that the equipment cannot be repaired remotely, two trained technicians are stationed within two hours of the Agency PSAP to facilitate onsite repairs.

Items excluded from maintenance include any software which is at a revision level not supported by the Software licensor. AT&T makes no guarantee as to parts availability on Equipment that has been discontinued by its manufacturer. In the event a manufacturer discontinues producing any equipment or in the event the equipment has outlived the manufacturer's suggested product life cycle, AT&T will continue to provide Service under the Maintenance Plan for as long as parts are available on a commercially reasonable basis. In the event repair parts are not readily available, AT&T will advise customer and customer will have the option to replace the Equipment with a similar product. AT&T offers at the prevailing rates. In the event the customer declines to authorize such replacement, AT&T will cease providing Service for such Equipment.

If persons other than AT&T and/or their subcontractor(s) have performed maintenance or repair of equipment, and, as a result, further repair by AT&T and/or their subcontractor(s) is required, such further repairs will be made at AT&T's then applicable time and material rates.

AT&T includes a one-year warranty and years two through five on a maintenance contract through the State of California Contract.

### **POWER 911/VIPER**

- AT&T will provide a "Maintenance Kit" to be kept at a location readily accessible to AT&T Technicians or, in some special cases, due to an Agency's location or system size, kept on site in a secured location. The contents of the Maintenance Kit will be

based upon the requirements of the *Agency's* 9-1-1 system. AT&T absorbs the cost of the Maintenance Kit and the equipment provided within the kit will remain the property of AT&T.

- AT&T includes five-year parts and labor on the 9-1-1 system. The five-year period begins at date of customer acceptance. After the five-year period, the *Agency* may choose to replace the system, maintain it, or a maintenance contract will be created with agreed terms, conditions and costs. Service packs, and hot fixes will be kept current and upgraded at no charge (additional features and hardware may not be included). Operating System upgrades are not included.

## 7.2 Post-Installation Support Limitations

AT&T's support obligations hereunder will not apply to any AT&T supported product if adjustment, repair, or parts replacement is required because of:

- Printer ink and paper are not included under maintenance.
- Accident, neglect, tampering, misuse, improper / insufficient grounding, failure of electric power; failure of the PSAP and/or others to provide appropriate environmental conditions, relocation of hardware or software, or causes other than ordinary use
- Repair or alteration, or attempted repair or alteration of any AT&T supported product (hardware and/or software) by the PSAP or others
- Connection of another machine, device, application or interface to AT&T supported equipment (hardware and/or software) by , *Agency*, the PSAP or others, which has caused damage to AT&T supported equipment
- Degradation of performance to AT&T systems due to non-compliance with the Customer Site Preparation Requirements (excessive heat, humidity, moisture, condensation, dust, EMI, etc.) as identified in AT&T document TP76911, Section C, Part 2, is not covered under Maintenance or Warranty.
- Damage or destruction caused by natural or man-made acts or disasters
- Degradation of performance to AT&T systems due to the installation of third party software applications or Operating System patches, service packs, hot-fixes, or Windows services and not specifically certified, approved, and registered by AT&T for use at the site(s) identified herein.
- Support described herein does not include cosmetic repairs, refurbishment, furnishing consumables, supplies or accessories, making accessory changes or adding additional devices or software applications.

## 7.3 Repair of Unsupported Failures

The *Agency* may request Field engineering to rectify unsupported failures, as defined above, on a Time & Materials basis. Labor rate charged will be the current AT&T labor rate (plus expenses) at the time service is requested.

**AT&T is NOT responsible for the performance of third party applications/systems.**

## **8.0 TRAINING**

### **8.1 Supervisor/Dispatcher Training**

AT&T and/or its subcontractor will provide Call-taker/Dispatcher and Supervisor/System Administrator training for the Power 911, Power MIS. The training will be done at the *Agency's* site. Each Call-Taker/Dispatcher or Supervisor/System Administrator refresher class will last approximately half an hour. The training will be done during normal business hours (6 am – 6 pm) Monday through Friday.

### **8.2 Training Documentation**

Training documentation may include hard-copies of the User Guide per site, and one soft-copy will be installed on each workstation. Documentation will be given to the *Agency's* designated training coordinator or during class.

### **8.3 Service Manual Documentation**

IWS Technical Installation and Maintenance Manuals will be provided with the delivery of the systems. These technical manuals should be kept in the equipment room near the equipment racks for the AT&T technicians to utilize as necessary.

## 9.0 DOCUMENT ACCEPTANCE



Arcadia PD

Power 911/VIPER Project

I have read the preceding document version 3.0. I understand and approve of the scope of work described therein. In addition, I understand that subsequent modifications to the scope of work will be requested on the attached Change Request Form and approved by both Arcadia PD and AT&T.

\_\_\_\_\_  
Arcadia PD

\_\_\_\_\_  
Date

\_\_\_\_\_  
Application Sales Executive, AT&T California

\_\_\_\_\_  
Date

## Appendix A: Agency Compliance - Site Certification Document

### Arcadia PD Compliance - Site Certification Document

This Section meets the State contract requirement for AT&T to provide a Site Readiness Checklist to the *Agency*.

A site survey has been made and site modifications will be needed to meet the following requirements for equipment installation. The following site modifications must be completed by the *Agency* prior to AT&T beginning the installation of the new or upgraded system. The completion of all building modifications are the responsibility of the *Agency*. In the event that AT&T attempts to begin installation and subsequently discovers that these modifications have not been met as specified, AT&T may postpone implementation. A quote will be provided to the *Agency* for any additional costs incurred by AT&T because of the postponement. Any additional costs that are incurred for site modifications because of the postponement will be the responsibility of the *Agency*. Work will be rescheduled upon completion of the required modifications.

#### Hazardous Materials

Customer will maintain Customer's location where AT&T is to perform work in a suitable and safe working environment, free of Hazardous Materials. AT&T does not handle, remove or dispose of, nor does AT&T accept any liability for, any Hazardous Materials at Customer's location. If AT&T encounters any such Hazardous Materials, AT&T may terminate this Statement of Work or suspend performance until Customer removes and cleans up at its expense Hazardous Materials in accordance with this Statement of Work and applicable law. For purposes hereof, "Hazardous Materials" means any substance whose use, transport, storage, handling, disposal, or release is regulated to any law related to pollution, protection of air, water, or soil, or health and safety.

- 1) Provide backroom space for VIPER cabinet
- 2) Provide two dedicated NEMA 5-20R (20 amp) circuits for VIPER cabinet (verify existing has sufficient power)
- 3) Provide one dedicated NEMA 5-15/20R (15/20 amp) circuit for each 911 position
- 4) Provide broadband access for remote connectivity (see Section 2.2 'Firewall' above).
- 5) IP and wiring to NetClock location (see Section 2.2 'NetClock' above).
- 6) Power for the TimeView display (see Section 2.2 'NetClock' Above).

Authorized Agency Representative understands that the modifications listed above must be complete prior to AT&T commencing installation.

\_\_\_\_\_  
Authorized Agency Representative accepts modification list.

\_\_\_\_\_  
Date

.....  
\_\_\_\_\_  
Authorized Agency Representative certifies modifications complete.

\_\_\_\_\_  
Date

## AT&T LAN/WAN PSAP Security Policy

It is AT&T's policy to install 911 equipment only in a secure PSAP Local Area Network ("LAN") that is not connected to any other computer network outside of AT&T's control (with the exception of the national Crime Information Center network or similar network, but only if such connection is expressly approved in writing by AT&T, which approval will be in AT&T's sole discretion).

AT&T will not install or terminate a PSAP LAN to a firewall. AT&T will identify the demarcation point for the PSAP LAN, beyond which AT&T is not responsible. In the event the customer has previously connected or subsequently connects their PSAP LAN to any other computer network or has caused or causes such a connection, contrary to AT&T's PSAP Network Security Policy (which customer acknowledges it has received and read), and the 911 equipment and/or PSAP LAN is infected or damaged as a result of such connection, then all 911 equipment and/or PSAP LAN warranties, maintenance, and service provisions of this amendment or statement of work will be immediately null and void. Under such circumstances, AT&T will provide repair services for the 911 equipment and/or PSAP LAN at Customer's request and time and materials charges will apply for all parts and labor required as a result of damage caused by the infection. After all related damage has been repaired, maintenance and service provisions of this agreement will resume.

# Appendix C: Dispatch and Equipment Floor Plans

## FOOTPRINT OF DISPATCH

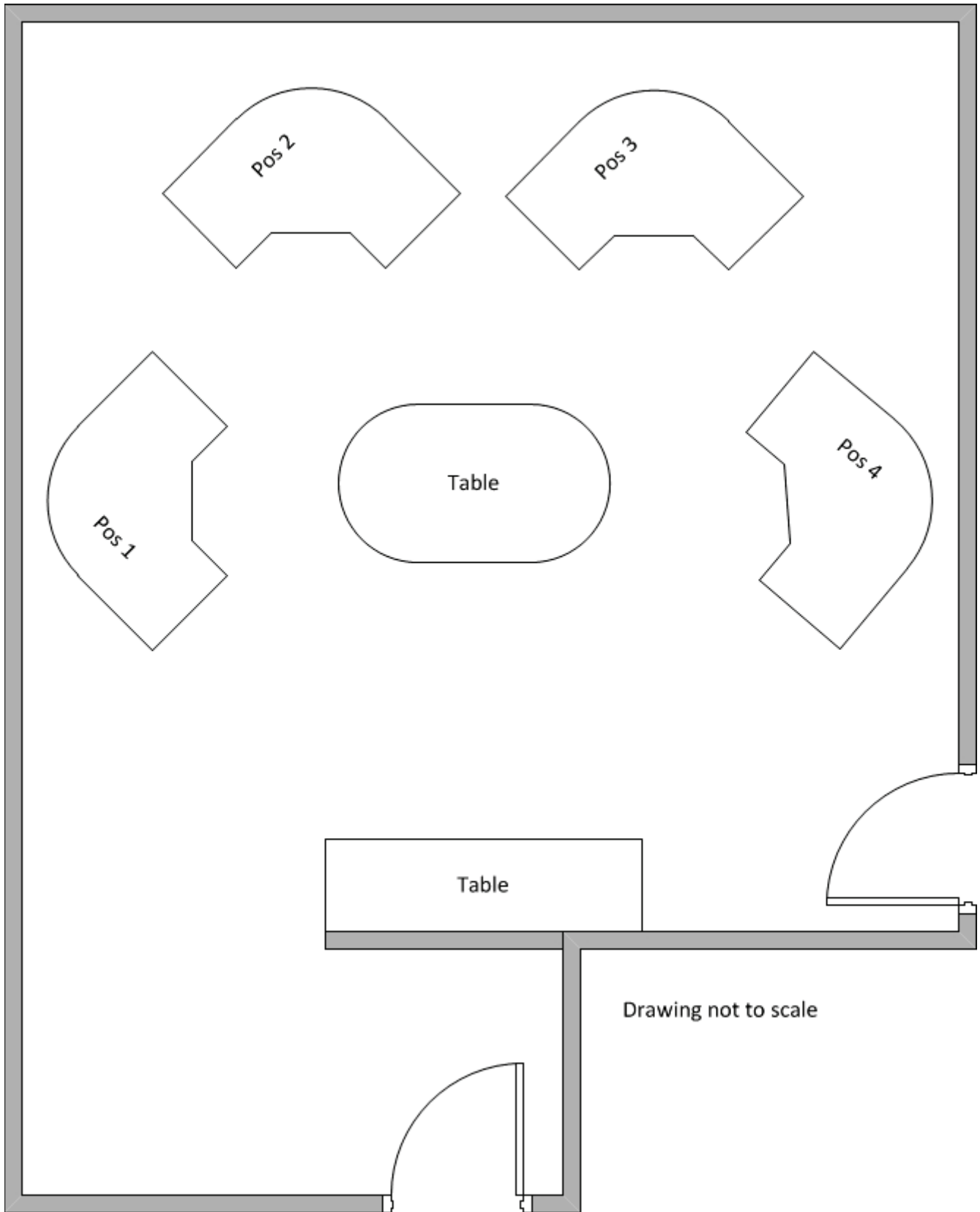

# FOOTPRINT OF EQUIPMENT ROOM

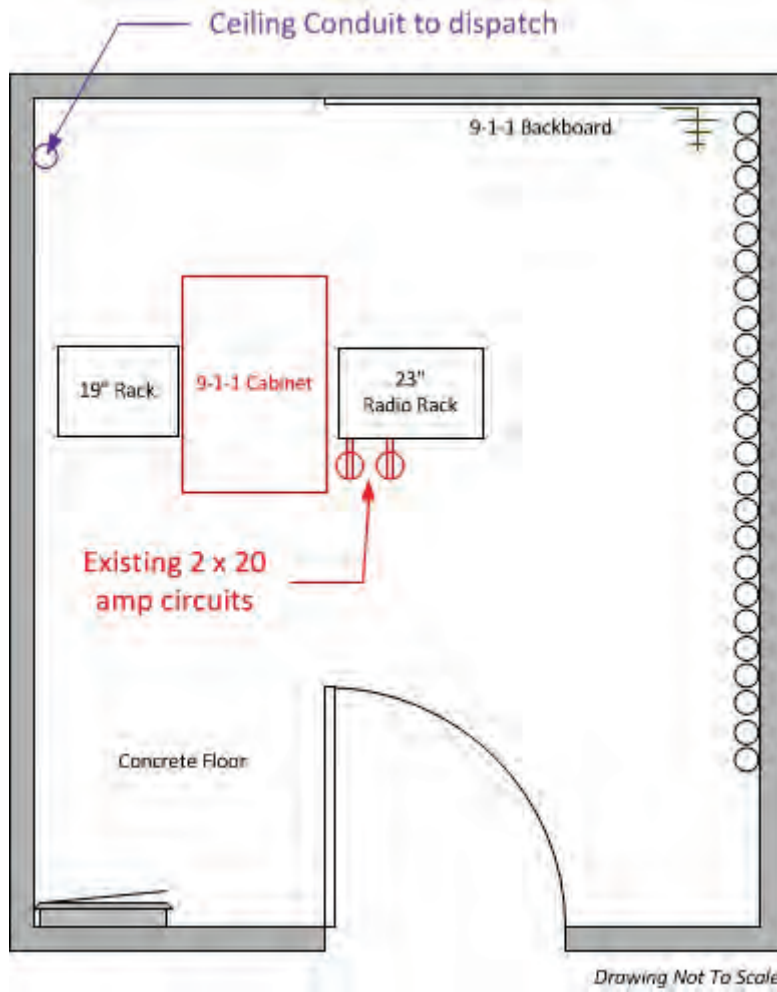

## Appendix D: Pricing & Terms

*Please refer to separate document.*

## Appendix E: Change Order Request Form

AT&T Project Office

---

### Change Request Form: Arcadia PD

Change Orders cannot be billed directly to the State without State approval.  
The Agency will be billed and must submit a reimbursement request to the State.

**Originator:**

**Change Request Definition:**

To be completed by Project Manager

**Impact to System Schedule:**

**Impact to Overall Project Schedule:**

**Development Price:**

<b>Change Request #:</b>	<b>Date:</b>
<b>System Affected:</b>	
<b>Accepted</b>	<b>Rejected:</b>

<b>Final AT&amp;T Signoff:</b>	<b>Final Agency Signoff:</b>	<b>Date:</b>
--------------------------------	------------------------------	--------------

## Appendix F: Maintenance Procedures

# “AT&T”

## PROVIDING PRODUCT & SERVICE EXCELLENCE

### TROUBLE REPORTING PROCEDURES

The Customer Assistance Bureau (CAB) is the trouble reporting center for our priority Public Safety Agencies. The center is responsible for receiving *Agency* reports and electronically relaying the reports to the responsible work groups for resolution, 24 hours a day, 365 days a year. The CSB can escalate trouble reports and put you in contact with management personnel responsible for resolving the trouble you have reported.

**The Priority Repair Service number is:**

**(877) 500-4911**

Due to the complexity of the services we provide and your own equipment ***it is essential that you isolate trouble before reporting to AT&T.*** A few extra minutes to properly identify, isolate and report a trouble can save hours in resolution time. Reporting the wrong trouble or circuit number may cause extended delays in our ability to deploy the appropriate work crew to repair the problem.

**When you call in a report, please be ready to provide the following information:**

1. Your name and call back telephone number.
2. Address and the location of trouble.
3. Telephone numbers or circuit number in trouble.
4. Nature of the trouble/condition.
5. Application the circuit is used for.
6. Access restrictions we may have to resolve trouble report.
7. Any terminal access problems or arrangements before dispatch.
8. The name of the contact person and their office number is a must!
9. Identification of Major or Minor Failure. (Defined below)
10. For urgent restorations you can ask for an hourly status from the Plant Control Office/PCO.

**Major Failure** - Definition of Major Failure: Any hardware, software or circuitry failure that prevents the 9-1-1 PSAP call taker from making voice or TDD contact or viewing ANI information or ALI information from a person who has dialed 9-1-1. Upon verbal notification by the *Agency*, or electronic notification by the 9-1-1 system itself, of a major failure, AT&T will meet the required response time detailed below:

**ONSITE RESPONSE:** A factory-trained technician will respond on-site with spare parts/software within two (2) hours, or less, to diagnose and commence repair of a major failure. (The initial replacement of some components may not be identical to the defective part (monitor, keyboard, mouse, speakers, etc.). This is to provide an expeditious restoration. An identical replacement

part will be provided within 72 hours.) Within two (2) hours, or less, the responding technician will notify the PSAP of the nature of failure and an estimated time to effect repairs.

**Minor Failure** - Definition of Minor Failure: Any hardware, software or circuitry failure that prevents the normal operation of any feature of the 9-1-1 system. Upon verbal notification by the *Agency*, or electronic notification by the 9-1-1 system itself, of a minor failure AT&T will meet the required response time detailed below:

ONSITE RESPONSE: During the initial notification by the PSAP *Agency* of a minor failure, the *Contractor* will provide to the PSAP *Agency* an estimated time for on-site diagnostics/repairs to begin. A factory trained technician will respond on-site with spare parts/software within twenty four (24) hours, or less, to diagnose and repair a minor failure. (The initial replacement of some components may not be identical to the defective part (monitor, keyboard, mouse, speakers, etc.). This is to provide an expeditious restoration. An identical replacement part will be provided within 72 hours.) Within twenty four (24) hours, or less, the responding technician will notify the PSAP of the nature of failure and an estimated time to effect repairs.

**Attachment No. 3**



DATE **4/8/2026**

**Support Agreement Quote**

**Arcadia PD**

**Support Agreement**

**AT&T Contact** **Robert Russo**  
**Phone** (951) 500-2130  
**Email** [rr1713@att.com](mailto:rr1713@att.com)  
**Address** 3580 Orange Street #104  
 Riverside, CA 92501

4 Position VIPER

**9-1-1 CPE BASIC TURN-KEY STAND-ALONE SYSTEM**

Turn-key System

12 Months Maintenance	\$ 19,072.72
-----------------------	--------------

Support Agreement Term: 12/07/2025 to 12/06/2026

Backroom UPS Replacement Quantity  
 Position UPS Replacement Quantity

2	\$ 10,274.00
4	\$ 4,780.00

*AT&T will continue to provide Service under the Support Plan for as long as parts are available on a commercially reasonable basis.*

*In the event repair parts are not readily available:*

*AT&T will advise customer and customer will have the option to replace the Equipment with a similar product.*

*In the event the customer declines to authorize such replacement, AT&T will cease providing Service for such Equipment.*

UPS	\$ 15,054.00
Tax 10.50%	\$ 1,580.67
<b>SYSTEM SUPPORT PLAN TOTAL</b>	\$ 19,072.72

This Quote Valid until 8/6/2026

<b>TOTAL</b>	\$ 35,707.39
--------------	--------------

**Attachment No. 4**

RESOLUTION NO. 7701

A RESOLUTION OF THE CITY COUNCIL OF THE CITY OF ARCADIA, CALIFORNIA, AUTHORIZING A SUPPLEMENTAL BUDGET APPROPRIATION IN THE AMOUNT OF \$35,707, FROM THE GENERAL FUND RESERVE; AND APPROVING THE SUPPORT AGREEMENT RENEWAL FOR THE POWER911/VIPER SYSTEM AND PURCHASE ORDER FOR RELATED EQUIPMENT WITH AT&T, IN AN AMOUNT NOT TO EXCEED \$35,707

WHEREAS, the Arcadia Police Department (“Department”) utilizes the Power911/VIPER (Voice over IP Emergency Response) system for managing 911 calls and associated equipment. This system ensures that emergency calls are handled swiftly and efficiently, allowing dispatchers to quickly connect individuals in distress with the necessary services; and

WHEREAS, AT&T is the current equipment and maintenance provider of the Power911/VIPER system. AT&T recently notified the City that the Support Agreement for maintenance is due for renewal, costing \$19,072.72. Additionally, the uninterruptible power supply (“UPS”), which serves as a backup battery for the 911 system needs replacement at \$15,054. The total cost is approximately \$35,707; and

WHEREAS, the Support Agreement expired in December 2025 and there was a delay in notification because of recent staffing changes. Despite the Support Agreement having expired in December 2025, AT&T has continued to provide uninterrupted maintenance service. The renewal period of the Support Agreement will be from December 7, 2025, to December 6, 2026; and

WHEREAS, due to the delay in notification of the Support Agreement renewal and the UPS replacement, funds were not allocated for this expense in the Fiscal Year 2025-26 General Fund Operating budget. Consequently, a budget appropriation from the Fiscal Year 2025-26 General Fund Reserve in the amount of \$35,707 is necessary to cover the expense; and

WHEREAS, the California Governor's Office of Emergency Services ("Cal OES") serves as the primary administrator, funder, and modernizer of the statewide 911 emergency communications system and will reimburse the City the total cost of the Support Agreement renewal and UPS replacement.

NOW, THEREFORE, THE CITY COUNCIL OF THE CITY OF ARCADIA, CALIFORNIA, DOES FIND, DETERMINE AND RESOLVE AS FOLLOWS:

SECTION 1. The sum of thirty five thousand, seven hundred seven dollars and zero cents (\$35,707) is hereby appropriated to the fiscal year 2025-26 General Fund Operating Budget and will cover the expense of the Support Agreement renewal with AT&T and the UPS system replacement.

SECTION 2. The City Clerk shall certify to the adoption of this Resolution.

[SIGNATURES ON THE NEXT PAGE]

Passed, approved, and adopted this 16th day of June 2026.

---

Mayor of the City of Arcadia

ATTEST:

---

City Clerk

APPROVED AS TO FORM:



---

Michael J. Maurer  
City Attorney

**DATE:** June 16, 2026

**TO:** Honorable Mayor and City Council

**FROM:** Darlene Bradley, Library and Museum Services Director

**SUBJECT:** DONATION FROM THE FRIENDS OF THE GILB MUSEUM OF ARCADIA HERITAGE FOR PROGRAMMING AND SUPPLIES IN THE AMOUNT OF \$12,550

**CEQA: Not a Project**

**Recommendation: Accept**

### **SUMMARY**

The Friends of the Gilb Museum of Arcadia Heritage have offered a donation of \$12,550 to support a variety of programs and the purchase of supplies for the Gilb Museum. It is recommended that the City Council accept the donation of \$12,550 to support programming and supplies at the Gilb Museum of Arcadia Heritage.

### **DISCUSSION**

As part of their ongoing mission to help support the Gilb Museum's goals and objectives, the Friends of the Gilb Museum (the "Friends"), are donating \$12,550 to the Gilb Museum to fund a variety of programs. Funding will be used to support programs that include the annual Snow Globe event, the 2026 Summer Enrichment Program, 2026 Dino Day, the 2026 Preschool Program, as well as Community Educational Kits, preservation workshops, Route 66 Tote Bags, and promotional materials.

The funds donated by the Friends help the Gilb Museum provide high-quality programs for the Arcadia community, beyond the current capacity of the Museum's Operating Budget. All gifts to the Museum over \$10,000 are subject to approval by the City Council pursuant to City Charter Section 1218 and Resolution No. 7514.

## **ENVIRONMENTAL ANALYSIS**

The proposed action does not constitute a project under Section 15061(b)(3) of the California Environmental Quality Act ("CEQA"), as it can be seen with certainty that it will have no impact on the environment.

## **FISCAL IMPACT**

The Gilb Museum of Arcadia Heritage's programming for the residents of Arcadia is enhanced by this gift of \$12,550, including the programs for children, teens, and adults that it will fund.

## **RECOMMENDATION**

It is recommended that the City Council determine this action does not constitute a project under the California Environmental Quality Act ("CEQA"); and accept a donation from the Friends of the Gilb Museum of Arcadia Heritage for programming and supplies in the amount of \$12,500.

Approved:



Dominic Lazzaretto  
City Manager

**DATE:** June 16, 2026

**TO:** Honorable Mayor and City Council

**FROM:** Darlene Bradley, Library and Museum Services Director

**SUBJECT:** DONATION FROM THE FRIENDS OF THE ARCADIA PUBLIC LIBRARY FOR LIBRARY PROGRAMMING IN THE AMOUNT OF \$50,000  
**CEQA: Not a Project**  
**Recommendation: Accept**

### **SUMMARY**

The Friends of the Arcadia Public Library have offered a donation of \$50,000 to fund Library services, including the popular summer reading program and teen programming. It is recommended that the City Council accept this donation of \$50,000 to support programming at the Arcadia Public Library.

### **DISCUSSION**

As part of their ongoing mission to support the Library's goals and objectives, the Friends of the Arcadia Public Library (the "Friends"), are donating \$50,000 to the Library to fund ongoing programming for children, teens, and adult programs. The Friends of the Arcadia Public Library raise funds through the sale of used books in the Friends Bookstore, located inside the Arcadia Public Library. The Friends also raise funds by selling Friends memberships, hosting several daylong book sales, and selling gently used items on eBay.

The funds donated by the Friends help the Arcadia Public Library provide quality programs for the community, specifically children and teens, beyond the current capacity of the Department's Operating Budget. All gifts over \$10,000 are subject to approval by the City Council pursuant to City Charter Section 1218 and Resolution No. 7514.

## **ENVIRONMENTAL ANALYSIS**

The proposed action does not constitute a project under Section 15061(b)(3) of the California Environmental Quality Act ("CEQA"), as it can be seen with certainty that it will have no impact on the environment.

## **FISCAL IMPACT**

The Library's programming for the residents of Arcadia is enhanced by this gift of \$50,000, including the programs for children, teens, and adults that it will fund.

## **RECOMMENDATION**

It is recommended that the City Council determine this action does not constitute a project under the California Environmental Quality Act ("CEQA"); and accept a donation from the Friends of the Arcadia Public Library for library programming in the amount of \$50,000.

Approved:



Dominic Lazzaretto  
City Manager

**DATE:** June 16, 2026

**TO:** Honorable Mayor and City Council

**FROM:** Dominic Lazzaretto, City Manager  
By: Justine Bruno, Deputy City Manager

**SUBJECT:** PROFESSIONAL SERVICES AGREEMENT WITH STUDIO SPECTRUM, INC. FOR CITY COUNCIL MEETING BROADCAST AND RECORDING SERVICES, FROM JULY 1, 2026, THROUGH JUNE 30, 2029, IN AN AMOUNT NOT TO EXCEED \$42,120 PER YEAR, WITH THE OPTION OF TWO ONE-YEAR RENEWALS

**CEQA: Not a Project**

**Recommendation: Approve**

## **SUMMARY**

For more than 30 years, Studio Spectrum, Inc. has provided broadcast and recording services for Arcadia City Council meetings. The City of Arcadia has continually selected Studio Spectrum, Inc. ("Studio Spectrum") to provide broadcast and web streaming services based on their extensive knowledge of the Council Chambers equipment and operating systems, as well as their reliability, responsiveness, and professionalism.

With the current contract for these services set to expire, the City Manager's Office issued a Request for Proposals ("RFP") to secure the best combination of service quality and competitive pricing. Studio Spectrum responded with a proposal to provide broadcast and recording services that best meet the City's needs. It is recommended that the City Council authorize and direct the City Manager to execute a Professional Services Agreement with Studio Spectrum, Inc. for City Council meeting broadcast and recording services, from July 1, 2026, through June 30, 2029, in an amount not to exceed \$42,120 annually, with the option of two one year-renewals. It is further recommended that the City Council delegate the authority to approve future extension under this agreement to the City Manager, without having

to return to the City Council for approval, provided that any changes to the financial terms remain within standard inflationary limits.

## **BACKGROUND**

To provide broadcast and recording services for City Council meetings, the selected vendor must provide pre-production services, including graphics, images, and sound, camera adjustments, live switching, audio and lighting management, support for City staff presentations, a live web stream, indexing, and an on-demand video library, program channel playback programming, and produce recorded copies in alignment with the City's Records Retention Schedule.

In 1996, the City of Arcadia first began televising its City Council meetings. Since that time, Studio Spectrum has provided broadcast services for Arcadia, which now include both television and web-streaming services. Studio Spectrum completed the original design and installation of the City's first audiovisual system in the Council Chambers and has performed necessary upgrades and maintenance on Arcadia's system over the years. Due to their in-depth knowledge of Arcadia's broadcast environment as well as their responsiveness, experience, competitive pricing, and high-quality services, Studio Spectrum has been ideal vendor to provide these services to the City for over three decades.

## **DISCUSSION**

In April 2026, the City Manager's Office issued a Request for Proposals ("RFP") for City Council Meeting Broadcast and Recording Services. In response to the RFP, the City received one proposal from Studio Spectrum, Inc. A panel of staff from the City Manager's Office reviewed the proposal and rated its thoroughness and understanding of the scope of work, related experience, references, proposal quality, and costs. The results of the evaluation with the final score are shown below:

<b>Ranking</b>	<b>Vendor Name</b>	<b>Score</b>	<b>Annual Cost</b>
1	Studio Spectrum, Inc.	97	\$42,120

City staff contacted local vendors that provide the requested services to inquire why proposals were not submitted; however, no responses were received.

Studio Spectrum’s proposal is segmented into three areas, detailed below:

- **Live Broadcast Services - \$1,000 per meeting**  
Includes a two-person production crew, pre-production support and on-site technical support during the City Council meetings.
- **Live Video Streaming and On-Demand Video Indexing, Publishing, and Archiving - \$485 per meeting**  
Includes maintaining a secure web portal where the live stream and on-demand videos can be accessed 24/7.
- **Video Captions**  
Live Web Stream - \$60/hour (one language)  
Video On Demand - \$150 per meeting (one language)  
Note: This service will be implemented in alignment with the associated federal standards and deadlines, further explained below.

Compared to the City’s current contract with Studio Spectrum, this proposal represents a minimum increase of 2.3%, with additional costs expected in April 2027 for video caption services, which will vary depending on meeting length (table below assumes 2-hour minimum for Video Subtitling – Live Web Stream).

<b>Service</b>	<b>July 2021 - June 2024</b>	<b>July 2024 - June 2025</b>	<b>July 2025 - June 2026</b>	<b>July 2026 - June 2029</b>
Production, Broadcast & Recording	\$875	\$945	\$995	\$1,000
Web-streaming	\$375	\$405	\$455	\$485
Video Captions – Live Web Stream				\$60/hr.
Video Captions – On-Demand Playback				\$150/mtg.
Total per Meeting	\$1,250	\$1,350	\$1,450	\$1,755+
<b>TOTAL</b>	<b>\$35,000</b>	<b>\$35,000</b>	<b>\$35,000</b>	<b>\$42,120</b>

Unlike previous years, this year’s proposal asked vendors to provide live stream and on-demand video playback services in compliance with the Americans with

Disabilities Act (“ADA”) Title II Rules, Web Content Accessibility Guidelines (“WCAG”) 2.1 AA standards. These standards are applicable to municipalities with populations of 50,000 or greater by April 2027. Alternatively, staff are exploring options to use remote meeting technology to meet this requirement, which may be provided at no added costs. Nevertheless, the cost of video captioning to meet this standard has been included in the pricing above to provide the City with the greatest flexibility going forward.

### **ENVIRONMENTAL ANALYSIS**

The proposed action does not constitute a project under the California Environmental Quality Act (“CEQA”), as it can be seen with certainty that it will have no impact on the environment.

### **FISCAL IMPACT**

In anticipation of a new contract and increased federal standards, additional funding was included in the FY2026-27 Proposed Operating Budget for City Council broadcast and recording services. If approved, the budget for this service is planned to increase to \$42,000 and will be sufficient to cover the proposed Professional Services Agreement.

### **RECOMMENDATION**

It is recommended that the City Council determine that this action is not a project under the California Environmental Quality Act (“CEQA”); and authorize and direct the City Manager to execute a Professional Services Agreement with Studio Spectrum, Inc. for City Council Meeting broadcast and recording services, from July 1, 2026, through June 30, 2029, in an amount not to exceed \$42,120 annually, with the option of two one year-renewals. It is further recommended that the City Council delegate the authority to approve future extension under this agreement to the City Manager, without having to return to the City Council for approval, provided that any changes to the financial terms remain within standard inflationary limits.

Attachment: Proposed Professional Services Agreement

**CITY OF ARCADIA**  
**PROFESSIONAL SERVICES AGREEMENT REGARDING**  
**[\*\*\*INSERT PROJECT TITLE\*\*\*]**

This Agreement is made and entered into as of \_\_\_\_\_, 20\_\_\_\_ by and between the City of Arcadia, a municipal corporation organized and operating under the laws of the State of California with its principal place of business at 240 West Huntington Drive, Arcadia, California 91066 ("City"), and [\*\*\*INSERT NAME\*\*\*], a [\*\*\*INSERT TYPE OF ENTITY - CORPORATION, PARTNERSHIP, SOLE PROPRIETORSHIP OR OTHER LEGAL ENTITY\*\*\*] with its principal place of business at [\*\*\*INSERT ADDRESS\*\*\*] (hereinafter referred to as "Consultant"). City and Consultant are sometimes individually referred to as "Party" and collectively as "Parties" in this Agreement.

**RECITALS**

A. City is a public agency of the State of California and is in need of professional services for the following project:

\_\_\_\_\_ (hereinafter referred to as "the Project").

B. Consultant is duly licensed and has the necessary qualifications to provide such services.

C. The Parties desire by this Agreement to establish the terms for City to retain Consultant to provide the services described herein.

**AGREEMENT**

**NOW, THEREFORE, IT IS AGREED AS FOLLOWS:**

1. Services.

Consultant shall provide the City with the services described in the Scope of Services attached hereto as Exhibit "A." **[Alternatively, Scope of Services can be included here and all subsequent exhibits renumbered accordingly.]**

2. Compensation.

a. Subject to paragraph 2(b) below, the City shall pay for such services in accordance with the Schedule of Charges set forth in Exhibit "B." **[Alternatively, Schedule of Charges may be included here and all subsequent exhibits renumbered accordingly.]**

b. In no event shall the total amount paid for services rendered by Consultant under this Agreement exceed the sum of \$\_\_\_\_\_ **[Insert amount of compensation]**. This amount is to cover all printing and related costs, and the City will not pay any additional fees for printing expenses. Periodic payments shall be made within 30 days of receipt of an invoice which includes a detailed description of the work performed. Payments to Consultant for work performed will be made on a monthly billing basis.

3. Additional Work.

If changes in the work seem merited by Consultant or the City, and informal consultations with the other party indicate that a change is warranted, it shall be processed in the following manner: a letter outlining the changes shall be forwarded to the City by Consultant with a statement of estimated changes in fee or time schedule. An amendment to this Agreement shall be prepared by the City and executed by both Parties before performance of such services, or the City will not be required to pay for the changes in the scope of work. Such amendment shall not render ineffective or invalidate unaffected portions of this Agreement.

4. Maintenance of Records.

Books, documents, papers, accounting records, and other evidence pertaining to costs incurred shall be maintained by Consultant and made available at all reasonable times during the contract period and for four (4) years from the date of final payment under the contract for inspection by City.

5. **[Insert Term or Time of Performance]**.

**[If engaging the Consultant for a particular term, use the following provision]**

The term of this Agreement shall be from **[Insert start date]** to **[Insert end date]**, unless earlier terminated as provided herein. The Parties may, by mutual, written consent, extend the term of this Agreement if necessary to complete the Project. Consultant shall perform its services in a prompt and timely manner within the term of this Agreement and shall commence performance upon receipt of written notice from the City to proceed ("Notice to Proceed"). **[If the City has specific milestones or timelines for performance, please input those requirements in the "Activity Schedule" attached as Exhibit C, otherwise delete Exhibit C.]** The Notice to Proceed shall set forth the date of commencement of work.

**[If engaging the Consultant to perform a discrete task with a specified deadline, use the following provision]**

Consultant shall perform its services in a prompt and timely manner and shall commence performance upon receipt of written notice from the City to proceed ("Notice to Proceed"). Consultant shall complete the services required hereunder within **[Insert**

**number of calendar days for performance of the services - if more detail is required attach "Activity Schedule" as Exhibit C, otherwise delete Exhibit C.]** The Notice to Proceed shall set forth the date of commencement of work.

6. Delays in Performance.

a. Neither City nor Consultant shall be considered in default of this Agreement for delays in performance caused by circumstances beyond the reasonable control of the non-performing party. For purposes of this Agreement, such circumstances include but are not limited to, abnormal weather conditions; floods; earthquakes; fire; epidemics; war; riots and other civil disturbances; strikes, lockouts, work slowdowns, and other labor disturbances; sabotage or judicial restraint.

b. Should such circumstances occur, the non-performing party shall, within a reasonable time of being prevented from performing, give written notice to the other party describing the circumstances preventing continued performance and the efforts being made to resume performance of this Agreement.

7. Compliance with Law.

a. Consultant shall comply with all applicable laws, ordinances, codes and regulations of the federal, state and local government, including Cal/OSHA requirements.

b. If required, Consultant shall assist the City, as requested, in obtaining and maintaining all permits required of Consultant by federal, state and local regulatory agencies.

c. If applicable, Consultant is responsible for all costs of clean up and/ or removal of hazardous and toxic substances spilled as a result of his or her services or operations performed under this Agreement.

8. Standard of Care

Consultant's services will be performed in accordance with generally accepted professional practices and principles and in a manner consistent with the level of care and skill ordinarily exercised by members of the profession currently practicing under similar conditions.

9. Assignment and Subconsultant

Consultant shall not assign, sublet, or transfer this Agreement or any rights under or interest in this Agreement without the written consent of the City, which may be withheld for any reason. Any attempt to so assign or so transfer without such consent shall be void and without legal effect and shall constitute grounds for termination. Subcontracts, if any, shall

contain a provision making them subject to all provisions stipulated in this Agreement. Nothing contained herein shall prevent Consultant from employing independent associates, and subconsultants as Consultant may deem appropriate to assist in the performance of services hereunder.

10. Independent Contractor

Consultant is retained as an independent contractor and is not an employee of City. No employee or agent of Consultant shall become an employee of City. The work to be performed shall be in accordance with the work described in this Agreement, subject to such directions and amendments from City as herein provided.

11. Insurance. Consultant shall not commence work for the City until it has provided evidence satisfactory to the City it has secured all insurance required under this section. In addition, Consultant shall not allow any subcontractor to commence work on any subcontract until it has secured all insurance required under this section.

a. Commercial General Liability

(i) The Consultant shall take out and maintain, during the performance of all work under this Agreement, in amounts not less than specified herein, Commercial General Liability Insurance, in a form and with insurance companies acceptable to the City.

(ii) Coverage for Commercial General Liability insurance shall be at least as broad as the following:

(1) Insurance Services Office Commercial General Liability coverage (Occurrence Form CG 00 01) or exact equivalent.

(iii) Commercial General Liability Insurance must include coverage for the following:

- (1) Bodily Injury and Property Damage
- (2) Personal Injury/Advertising Injury
- (3) Premises/Operations Liability
- (4) Products/Completed Operations Liability **Consultant shall procure and submit evidence of insurance for at least five (5) years from the time that all work under this Agreement is completed.**
- (5) Aggregate Limits that Apply per Project
- (6) Explosion, Collapse and Underground (UCX) exclusion deleted
- (7) Contractual Liability with respect to this Agreement
- (8) Property Damage

(9) Independent Consultants Coverage

(iv) The policy shall contain no endorsements or provisions limiting coverage for (1) contractual liability; (2) cross liability exclusion for claims or suits by one insured against another; (3) products/completed operations liability; or (4) contain any other exclusion contrary to the Agreement.

(v) The policy shall give City, its officials, officers, employees, agents and City designated volunteers additional insured status using ISO endorsement forms CG 20 10 10 01 and 20 37 10 01, or endorsements providing the exact same coverage. Consultant may provide blanket endorsements to meet the Additional Insured requirement in this written contract. However, all subcontractors' endorsements shall specifically name the City, its elected officials, officers, employees, volunteers, boards, agents, and representatives as additional insureds and blanket endorsements are not acceptable.

(vi) The general liability program may utilize either deductibles or provide coverage excess of a self-insured retention, subject to written approval by the City, and provided that such deductibles shall not apply to the City as an additional insured.

b. Automobile Liability

(i) At all times during the performance of the work under this Agreement, the Consultant shall maintain Automobile Liability Insurance for bodily injury and property damage including coverage for owned, non-owned and hired vehicles, in a form and with insurance companies acceptable to the City.

(ii) Coverage for automobile liability insurance shall be at least as broad as Insurance Services Office Form Number CA 00 01 covering automobile liability (Coverage Symbol 1, any auto).

(iii) The policy shall give City, its officials, officers, employees, agents and City designated volunteers additional insured status. Consultant may provide blanket endorsements to meet the Additional Insured requirement in this written contract. However, all subcontractors' endorsements shall specifically name the City, its elected officials, officers, employees, volunteers, boards, agents, and representatives as additional insureds and blanket endorsements are not acceptable.

(iv) Subject to written approval by the City, the automobile liability program may utilize deductibles, provided that such deductibles shall not apply to the City as an additional insured, but not a self-insured retention.

c. Workers' Compensation/Employer's Liability

(i) Consultant certifies that he/she is aware of the provisions of Section 3700 of the California Labor Code which requires every employer to be insured

against liability for workers' compensation or to undertake self-insurance in accordance with the provisions of that code, and he/she will comply with such provisions before commencing work under this Agreement.

(ii) To the extent Consultant has employees at any time during the term of this Agreement, at all times during the performance of the work under this Agreement, the Consultant shall maintain full compensation insurance for all persons employed directly by him/her to carry out the work contemplated under this Agreement, all in accordance with the "Workers' Compensation and Insurance Act," Division IV of the Labor Code of the State of California and any acts amendatory thereof, and Employer's Liability Coverage in amounts indicated herein. Consultant shall require all subconsultants to obtain and maintain, for the period required by this Agreement, workers' compensation coverage of the same type and limits as specified in this section.

d. Professional Liability (Errors and Omissions)

At all times during the performance of the work under this Agreement the Consultant shall maintain professional liability or Errors and Omissions insurance appropriate to its profession, in a form and with insurance companies acceptable to the City and in an amount indicated herein. This insurance shall be endorsed to include contractual liability applicable to this Agreement and shall be written on a policy form coverage specifically designed to protect against acts, errors or omissions of the Consultant. "Covered Professional Services" as designated in the policy must specifically include work performed under this Agreement. The policy must "pay on behalf of" the insured and must include a provision establishing the insurer's duty to defend.

**[Delete the following provision and renumber all further provisions, if not applicable.]**

e. Cyber Liability Insurance.

Cyber Liability Insurance covering (1) all acts, errors, omissions, negligence, infringement of intellectual property; (2) network security and privacy risks, including but not limited to unauthorized access, failure of security, breach of privacy perils, wrongful disclosure, collection, or negligence in the handling of confidential information, privacy perils, including coverage for related regulatory defense and penalties; (3) system failure, damage to or destruction of electronic information, data recovery, business interruption, cyber extortion, and information theft; (4) data breach expenses payable whether incurred by City or Consultant, including but not limited to consumer notification, whether or not required by law, computer forensic investigations, public relations and crisis management firm fees, credit file or identity monitoring or remediation services in the performance of services for City or on behalf of City hereunder. If a sub-limit applies to any elements of coverage, the certificate of insurance evidencing the coverage above must specify the coverage section and the amount of the sub-limit.

f. Minimum Policy Limits Required

(i) The following insurance limits are required for the Agreement:

Combined Single Limit

Commercial General Liability	\$1,000,000 per occurrence/ \$2,000,000 aggregate for bodily injury, personal injury, and property damage
Automobile Liability	\$1,000,000 per occurrence for bodily injury and property damage
Employer's Liability	\$1,000,000 per occurrence
Professional Liability	\$1,000,000 per claim and aggregate (errors and omissions)
<b>[Remove Cyber if not applicable. Common insurance for website hosting]</b>	
Cyber Liability	\$5,000,000 per claim and annual aggregate

(ii) Defense costs shall be payable in addition to the limits.

(iii) Requirements of specific coverage or limits contained in this section are not intended as a limitation on coverage, limits, or other requirement, or a waiver of any coverage normally provided by any insurance. Any available coverage shall be provided to the parties required to be named as Additional Insured pursuant to this Agreement.

g. Evidence Required

Prior to execution of the Agreement, the Consultant shall file with the City evidence of insurance from an insurer or insurers certifying to the coverage of all insurance required herein. Such evidence shall include original copies of the ISO CG 00 01 (or insurer's equivalent) signed by the insurer's representative and Certificate of Insurance (Acord Form 25-S or equivalent), together with required endorsements. All evidence of insurance shall be signed by a properly authorized officer, agent, or qualified representative of the insurer and shall certify the names of the insured, any additional insureds, where appropriate, the type and amount of the insurance, the location and operations to which the insurance applies, and the expiration date of such insurance.

h. Policy Provisions Required

(i) Consultant shall provide the City at least thirty (30) days prior written notice of cancellation of any policy required by this Agreement, except that the Consultant shall provide at least ten (10) days prior written notice of cancellation of any such

policy due to non-payment of premium. If any of the required coverage is cancelled or expires during the term of this Agreement, the Consultant shall deliver renewal certificate(s) including the General Liability Additional Insured Endorsement to the City at least ten (10) days prior to the effective date of cancellation or expiration. Consultant may provide blanket endorsements to meet the Additional Insured requirement in this written contract. However, all subcontractors' endorsements shall specifically name the City, its elected officials, officers, employees, volunteers, boards, agents, and representatives as additional insureds and blanket endorsements are not acceptable.

(ii) The Commercial General Liability Policy and Automobile Policy shall each contain a provision stating that Consultant's policy is primary insurance and that any insurance, self-insurance or other coverage maintained by the City or any named insureds shall not be called upon to contribute to any loss.

(iii) The retroactive date (if any) of each policy is to be no later than the effective date of this Agreement. Consultant shall maintain such coverage continuously for a period of at least three years after the completion of the work under this Agreement. Consultant shall purchase a one (1) year extended reporting period A) if the retroactive date is advanced past the effective date of this Agreement; B) if the policy is cancelled or not renewed; or C) if the policy is replaced by another claims-made policy with a retroactive date subsequent to the effective date of this Agreement.

(iv) All required insurance coverages, except for the professional liability coverage, shall contain or be endorsed to waiver of subrogation in favor of the City, its officials, officers, employees, agents, and volunteers or shall specifically allow Consultant or others providing insurance evidence in compliance with these specifications to waive their right of recovery prior to a loss. Consultant hereby waives its own right of recovery against City, and shall require similar written express waivers and insurance clauses from each of its subconsultants.

(v) The limits set forth herein shall apply separately to each insured against whom claims are made or suits are brought, except with respect to the limits of liability. Further the limits set forth herein shall not be construed to relieve the Consultant from liability in excess of such coverage, nor shall it limit the Consultant's indemnification obligations to the City and shall not preclude the City from taking such other actions available to the City under other provisions of the Agreement or law.

i. Qualifying Insurers

(i) All policies required shall be issued by acceptable insurance companies, as determined by the City, which satisfy the following minimum requirements:

(1) Each such policy shall be from a company or companies with a current A.M. Best's rating of no less than A:VII and admitted to transact in the

business of insurance in the State of California, or otherwise allowed to place insurance through surplus line brokers under applicable provisions of the California Insurance Code or any federal law.

j. Additional Insurance Provisions

(i) The foregoing requirements as to the types and limits of insurance coverage to be maintained by Consultant, and any approval of said insurance by the City, is not intended to and shall not in any manner limit or qualify the liabilities and obligations otherwise assumed by the Consultant pursuant to this Agreement, including but not limited to, the provisions concerning indemnification.

(ii) If at any time during the life of the Agreement, any policy of insurance required under this Agreement does not comply with these specifications or is canceled and not replaced, City has the right but not the duty to obtain the insurance it deems necessary and any premium paid by City will be promptly reimbursed by Consultant or City will withhold amounts sufficient to pay premium from Consultant payments. In the alternative, City may cancel this Agreement.

(iii) The City may require the Consultant to provide complete copies of all insurance policies in effect for the duration of the Project.

(iv) Neither the City nor any of its officials, officers, employees, agents or volunteers shall be personally responsible for any liability arising under or by virtue of this Agreement.

k. Subconsultant Insurance Requirements. Consultant shall not allow any subcontractors or subconsultants to commence work on any subcontract until they have provided evidence satisfactory to the City that they have secured all insurance required under this section. Policies of commercial general liability insurance provided by such subcontractors or subconsultants shall be endorsed to name the City as an additional insured using ISO form CG 20 38 04 13 or an endorsement providing the exact same coverage. All subcontractors' endorsements shall specifically name the City, its elected officials, officers, employees, volunteers, boards, agents, and representatives as additional insureds and blanket endorsements are not acceptable. If requested by Consultant, City may approve different scopes or minimum limits of insurance for particular subcontractors or subconsultants.

12. Indemnification.

a. To the fullest extent permitted by law, Consultant shall defend (with counsel of City's choosing), indemnify and hold the City, its officials, officers, employees, volunteers, and agents free and harmless from any and all claims, demands, causes of action, costs, expenses, liability, loss, damage or injury of any kind, in law or equity, to property or persons, including wrongful death, in any manner arising out of, pertaining to, or incident

to any acts, errors or omissions, or willful misconduct of Consultant, its officials, officers, employees, subcontractors, consultants or agents in connection with the performance of the Consultant's services, the Project or this Agreement, including without limitation the payment of all damages, expert witness fees and attorney's fees and other related costs and expenses. Consultant's obligation to indemnify shall not be restricted to insurance proceeds, if any, received by Consultant, the City, its officials, officers, employees, agents, or volunteers.

b. To the extent required by Civil Code section 2782.8, which is fully incorporated herein, Consultant's obligations under the above indemnity shall be limited to claims that arise out of, pertain to, or relate to the negligence, recklessness, or willful misconduct of the Consultant, but shall not otherwise be reduced. If Consultant's obligations to defend, indemnify, and/or hold harmless arise out of Consultant's performance of "design professional services" (as that term is defined under Civil Code section 2782.8), then upon Consultant obtaining a final adjudication that liability under a claim is caused by the comparative active negligence or willful misconduct of the City, Consultant's obligations shall be reduced in proportion to the established comparative liability of the City and shall not exceed the Consultant's proportionate percentage of fault.

13. California Labor Code Requirements.

a. Consultant is aware of the requirements of California Labor Code Sections 1720 et seq. and 1770 et seq., which require the payment of prevailing wage rates and the performance of other requirements on certain "public works" and "maintenance" projects ("Prevailing Wage Laws"). If the services are being performed as part of an applicable "public works" or "maintenance" project, as defined by the Prevailing Wage Laws, and if the total compensation is \$15,000 or more for maintenance or \$25,000 or more for construction, alteration, demolition, installation, or repair, Consultant agrees to fully comply with such Prevailing Wage Laws. Consultant shall defend, indemnify and hold the City, its officials, officers, employees and agents free and harmless from any claims, liabilities, costs, penalties or interest arising out of any failure or alleged failure to comply with the Prevailing Wage Laws. It shall be mandatory upon the Consultant and all subconsultants to comply with all California Labor Code provisions, which include but are not limited to prevailing wages (Labor Code Sections 1771, 1774 and 1775), employment of apprentices (Labor Code Section 1777.5), certified payroll records (Labor Code Sections 1771.4 and 1776), hours of labor (Labor Code Sections 1813 and 1815) and debarment of contractors and subcontractors (Labor Code Section 1777.1).

b. If the services are being performed as part of an applicable "public works" or "maintenance" project and if the total compensation is \$15,000 or more for maintenance or \$25,000 or more for construction, alteration, demolition, installation, or repair, then pursuant to Labor Code Sections 1725.5 and 1771.1, the Consultant and all subconsultants performing such services must be registered with the Department of Industrial Relations. Consultant shall maintain registration for the duration of the Project

and require the same of any subconsultants, as applicable. This Project may also be subject to compliance monitoring and enforcement by the Department of Industrial Relations. It shall be Consultant's sole responsibility to comply with all applicable registration and labor compliance requirements.

c. This Agreement may also be subject to compliance monitoring and enforcement by the Department of Industrial Relations. It shall be Consultant's sole responsibility to comply with all applicable registration and labor compliance requirements. Any stop orders issued by the Department of Industrial Relations against Consultant or any subcontractor that affect Consultant's performance of services, including any delay, shall be Consultant's sole responsibility. Any delay arising out of or resulting from such stop orders shall be considered Consultant caused delay and shall not be compensable by the City. Consultant shall defend, indemnify and hold the City, its officials, officers, employees and agents free and harmless from any claim or liability arising out of stop orders issued by the Department of Industrial Relations against Consultant or any subcontractor.

14. Verification of Employment Eligibility.

By executing this Agreement, Consultant verifies that it fully complies with all requirements and restrictions of state and federal law respecting the employment of undocumented aliens, including, but not limited to, the Immigration Reform and Control Act of 1986, as may be amended from time to time, and shall require all subconsultants and sub-subconsultants to comply with the same.

**[Delete the following provision and renumber all further provisions, if not applicable.]**

15. City Material Requirements.

Consultant is hereby made aware of the City's requirements regarding materials, as set forth in **[Insert the name of the document that contains the City's standard material requirements]**, which are deemed to be a part of this Agreement.

16. Laws and Venue.

This Agreement shall be interpreted in accordance with the laws of the State of California. If any action is brought to interpret or enforce any term of this Agreement, the action shall be brought in a state or federal court situated in the County of Los Angeles, State of California.

17. Termination or Abandonment

a. City has the right to terminate or abandon any portion or all of the work under this Agreement by giving ten (10) calendar days written notice to Consultant. In such event, City shall be immediately given title and possession to all original field notes, drawings and specifications, written reports and other documents produced or developed for that portion of the work completed and/or being abandoned. City shall pay Consultant the

reasonable value of services rendered for any portion of the work completed prior to termination. If said termination occurs prior to completion of any task for the Project for which a payment request has not been received, the charge for services performed during such task shall be the reasonable value of such services, based on an amount mutually agreed to by City and Consultant of the portion of such task completed but not paid prior to said termination. City shall not be liable for any costs other than the charges or portions thereof which are specified herein. Consultant shall not be entitled to payment for unperformed services, and shall not be entitled to damages or compensation for termination of work.

b. Consultant may terminate its obligation to provide further services under this Agreement upon thirty (30) calendar days' written notice to City only in the event of substantial failure by City to perform in accordance with the terms of this Agreement through no fault of Consultant.

18 Documents. Except as otherwise provided in "Termination or Abandonment," above, all original field notes, written reports, Drawings and Specifications and other documents, produced or developed for the Project shall, upon payment in full for the services described in this Agreement, be furnished to and become the property of the City.

19. Organization

Consultant shall assign [REDACTED] as Project Manager. The Project Manager shall not be removed from the Project or reassigned without the prior written consent of the City.

20. Limitation of Agreement.

This Agreement is limited to and includes only the work included in the Project described above.

21. Notice

Any notice or instrument required to be given or delivered by this Agreement may be given or delivered by depositing the same in any United States Post Office, certified mail, return receipt requested, postage prepaid, addressed to:

CITY:

City of Arcadia  
240 West Huntington Drive  
Arcadia, CA 91066

CONSULTANT:

[\*\*\*INSERT NAME, ADDRESS & CONTACT PERSON\*\*\*]

Attn: [\*\*\*INSERT NAME & DEPARTMENT\*\*\*]

and shall be effective upon receipt thereof.

22. Third Party Rights

Nothing in this Agreement shall be construed to give any rights or benefits to anyone other than the City and the Consultant.

23. Equal Opportunity Employment.

Consultant represents that it is an equal opportunity employer and that it shall not discriminate against any employee or applicant for employment because of race, religion, color, national origin, ancestry, sex, age or other interests protected by the State or Federal Constitutions. Such non-discrimination shall include, but not be limited to, all activities related to initial employment, upgrading, demotion, transfer, recruitment or recruitment advertising, layoff or termination.

24. Entire Agreement

This Agreement, with its exhibits, represents the entire understanding of City and Consultant as to those matters contained herein, and supersedes and cancels any prior or contemporaneous oral or written understanding, promises or representations with respect to those matters covered hereunder. Each party acknowledges that no representations, inducements, promises or agreements have been made by any person which are not incorporated herein, and that any other agreements shall be void. This Agreement may not be modified or altered except in writing signed by both Parties hereto. This is an integrated Agreement.

25. Severability

The unenforceability, invalidity or illegality of any provision(s) of this Agreement shall not render the provisions unenforceable, invalid or illegal.

26. Successors and Assigns

This Agreement shall be binding upon and shall inure to the benefit of the successors in interest, executors, administrators and assigns of each party to this Agreement. However, Consultant shall not assign or transfer by operation of law or otherwise any or all of its rights, burdens, duties or obligations without the prior written consent of City. Any attempted assignment without such consent shall be invalid and void.

27. Non-Waiver

None of the provisions of this Agreement shall be considered waived by either party, unless such waiver is specifically specified in writing.

28. Time of Essence

Time is of the essence for each and every provision of this Agreement.

29. City's Right to Employ Other Consultants

City reserves its right to employ other consultants, including engineers, in connection with this Project or other projects.

30. Prohibited Interests

Consultant maintains and warrants that it has not employed nor retained any company or person, other than a bona fide employee working solely for Consultant, to solicit or secure this Agreement. Further, Consultant warrants that it has not paid nor has it agreed to pay any company or person, other than a bona fide employee working solely for Consultant, any fee, commission, percentage, brokerage fee, gift or other consideration contingent upon or resulting from the award or making of this Agreement. For breach or violation of this warranty, City shall have the right to rescind this Agreement without liability. For the term of this Agreement, no director, official, officer or employee of City, during the term of his or her service with City, shall have any direct interest in this Agreement, or obtain any present or anticipated material benefit arising therefrom.

31. Federal Requirements [\*\*\*INCLUDE THIS SECTION ONLY IF APPLICABLE; DELETE OTHERWISE AND DELETE ASSOCIATED EXHIBIT. YOU MAY ALSO NEED TO INCLUDE SOME INFORMATION IN THE RFP DUE TO FEDERAL FUNDING GUIDELINES. CONSULT LEGAL COUNSEL IF NECESSARY\*\*\*]

When funding for the services is provided, in whole or in part, by an agency of the federal government, Consultant shall also fully and adequately comply with the provisions included in Exhibit "D" (Federal Requirements) attached hereto and incorporated herein by reference ("Federal Requirements"). With respect to any conflict between such Federal Requirements and the terms of this Agreement and/or the provisions of state law, the more stringent requirement shall control.

**[SIGNATURES ON FOLLOWING PAGE]**

**SIGNATURE PAGE FOR PROFESSIONAL SERVICES AGREEMENT  
BETWEEN THE CITY OF ARCADIA  
AND [\*\*\*INSERT NAME\*\*\*]**

IN WITNESS WHEREOF, the Parties have executed this Agreement as of the date first written above.

CITY OF ARCADIA

[INSERT NAME OF CONSULTANT]

By: \_\_\_\_\_  
Dominic Lazzaretto  
City Manager

By: \_\_\_\_\_  
Signature

Date: \_\_\_\_\_

Its: \_\_\_\_\_

ATTEST:

\_\_\_\_\_  
Printed Name

By: \_\_\_\_\_  
City Clerk

Date: \_\_\_\_\_

APPROVED AS TO FORM

By: \_\_\_\_\_  
Signature

By: \_\_\_\_\_  
Stephen P. Deitsch  
City Attorney

Its: \_\_\_\_\_

\_\_\_\_\_  
Printed Name

EXHIBIT A

Scope of Services

DRAFT

## EXHIBIT B

### Schedule of Charges/Payments

Consultant will invoice City on a monthly cycle. Consultant will include with each invoice a detailed progress report that indicates the amount of budget spent on each task. Consultant will inform City regarding any out-of-scope work being performed by Consultant. This is a time-and-materials contract.

DRAFT

EXHIBIT C

Activity Schedule

DRAFT

EXHIBIT D

Federal Requirements

DRAFT

**DATE:** June 16, 2026

**TO:** Honorable Mayor and City Council

**FROM:** Roy Nakamura, Chief of Police  
By: Amber Abeyta, Management Analyst

**SUBJECT:** PROFESSIONAL SERVICES AGREEMENT WITH INTER-CON SECURITY FOR OFFICIAL PARKING ENFORCEMENT SERVICES FOR A THREE-YEAR PERIOD BEGINNING JULY 1, 2026, THROUGH JUNE 30, 2029, WITH THE OPTION OF THREE, ONE-YEAR RENEWALS, IN AN AMOUNT NOT TO EXCEED \$937,596 FOR THE INITIAL THREE-YEAR PERIOD

**CEQA: Not a Project**

**Recommendation: Approve**

## **SUMMARY**

The Professional Services Agreement (“Agreement”) with Inter-Con Security (“Inter-Con”) for Official Parking Enforcement Services expires on June 30, 2026. It is recommended that the City Council approve, authorize, and direct the City Manager to execute a Professional Services Agreement with Inter-Con Security for official parking enforcement services for a three-year period, beginning July 1, 2026, through June 30, 2029, with the option of three one-year renewals, in an amount not to exceed \$937,596 for the initial three-year period. It is further recommended that the City Council delegate the authority to approve future renewals under this agreement to the City Manager, without returning to the City Council for approval, provided that any financial increases remain within recognized inflationary levels.

## **BACKGROUND**

Cities utilize parking enforcement to enhance public safety, traffic flow, and assist with distributing limited parking resources to a variety of users. The Arcadia Municipal Code also prohibits parking on public streets between the hours of 2:30

a.m. and 5:30 a.m. These restrictions were enacted to increase safety and security, as well as enhance the City's aesthetics.

Inter-Con has been the City's parking enforcement services provider since 2007. For the past 19 years, Inter-Con has been responsible for providing overnight parking, daytime street sweeping, and general parking enforcement throughout the City. Even though Inter-Con's performance has been positive, a Request for Proposals ("RFP") was issued in April 2026 to comply with the City's purchasing policy, which requires an evaluation of contracts through a formal bid process at least every six years, to ensure the City is receiving the most efficient and effective services.

**DISCUSSION**

A Notice Inviting Proposals was published on the City's website, and Inter-Con was the sole proposer. Another company, LAZ Parking, expressed interest in submitting a proposal; however, they ultimately did not provide one for undisclosed reasons.

Inter-Con is a San Gabriel Valley based company, with its headquarters located 7.6 miles from the City. Inter-Con has over 52 years of experience in providing customized security and parking enforcement solutions for federal, state, and local governments. Inter-Con has maintained a good relationship with the Arcadia Police Department and is the only local firm that provides parking enforcement services to our area. Other cities that have contracted with Inter-Con for parking enforcement services include the Cities of Alhambra, Pasadena, La Verne, Glendora, and Covina.

The new Agreement (Attachment No. 2) for parking enforcement services covers a three-year term, with the option of three additional one-year renewals, beginning July 1, 2026. The cost for the initial three-year term totals \$937,595.52 A breakdown of the annual cost is provided below. The specific costs are outlined in Attachment No. 1.

<b>Year 1 Fiscal Year 2026-27</b>	<b>Year 2 Fiscal Year 2027-28</b>	<b>Year 3 Fiscal Year 2028-29</b>
<b>\$284,631.68</b>	<b>\$311,672.64</b>	<b>\$341,291.20</b>

The total cost of \$284,631.68 for Year 1 represents an increase of 2.44% compared to last year's contract amount of \$277,842. An increase of 9.5% will occur in Years 2

and 3 as well. The increase is necessary to sustain the program over the new contract period. Most notably, Inter-Con replaced one vehicle (as the agreement mandates the provision of vehicles for this service) and must also account for the replacement cost of a second vehicle during the upcoming contract term. Additionally, non-wage operating costs that include fuel and vehicle-related expenses remain volatile and must be reasonably estimated over the contract period.

It's important to highlight that parking enforcement services are a significant revenue source. Over the past three years, the parking enforcement program generated \$1.52 million in parking citation revenue. There was a decrease in revenue collected during Fiscal Year 2025-26, attributed to a parking permit exemption following the Eaton Fire that occurred in January 2025. However, for FY 2026-27, revenue is anticipated to return to the average collection of approximately \$500,000.

Inter-Con has performed well in Arcadia for the past six years, satisfying all contract terms. Furthermore, they have submitted the only responsive proposal. Therefore, it is recommended that the City continue utilizing their services for a new three-year term, with the option of three one-year renewals.

### **ENVIRONMENTAL ANALYSIS**

The proposed action does not constitute a project under the California Environmental Quality Act ("CEQA"), based on Section 15061(b)(3) of the CEQA Guidelines, as it can be seen with certainty that it will have no impact on the environment.

### **FISCAL IMPACT**

Sufficient funds in the amount of \$284,632 for the first year of the Agreement have been allocated in the Fiscal Year 2026-27 General Fund Operating Budget. If approved, future years will be budgeted accordingly in the Department's Operating Budget.

### **RECOMMENDATION**

It is recommended that the City Council determine that this action does not constitute a project under the California Environmental Quality Act ("CEQA"); and

approve, authorize, and direct the City Manager to execute a Professional Services Agreement with Inter-Con Security for official parking enforcement services for a three-year period beginning July 1, 2026, through June 30, 2029, with the option of three, one-year renewals, in an amount not to exceed \$937,596 for the initial three-year period. It is further recommended that the City Council delegate the authority to approve future renewals under this agreement to the City Manager, without returning to the City Council for approval, provided that any financial increases remain within recognized inflationary levels.

Approved:

A handwritten signature in black ink, appearing to read "Paul Cummings". The signature is written in a cursive style with a horizontal line underneath the name.

Dominic Lazzaretto  
City Manager

Attachment No. 1: Official Parking Enforcement Services Proposed Billable Costs  
Attachment No. 2: Proposed Services Agreement

## Attachment No. 1

City of Arcadia  
Request for Proposal - Official Parking Enforcement Services (OPES)

### Official Parking Enforcement Services Proposed Billable Costs

Company Name: Inter-Con Security Systems, Inc.

Year 1															
Positions Classification	Job Duties	Labor Rate	Number of Staff	Daily Service Hours							Weekly	Total Annual Hours (52 weeks)	Hourly Billing Rate (Regular)	Post Coverage	
				Mon.	Tues.	Wed.	Thurs.	Fri.	Sat.	Sun.	Total Hours per Week			Weekly Cost	Annual Cost
Senior Parking Enforcement (Day)	Parking Enforcement & Supervision	\$ 23.00	1	8	8	8	8	8			40	2080	\$ 39.18	\$ 1,567.20	\$ 81,494.40
Senior Parking Enforcement (Grave)	Parking Enforcement & Supervision	\$ 26.50	-								0	0	\$ 45.14	\$ -	\$ -
Parking Enforcement (Grave)	Parking Enforcement	\$ 24.50	2	16	16	16	16	16			80	4160	\$ 42.20	\$ 3,376.00	\$ 175,552.00
Parking Enforcement Weekend (Grave)	Parking Enforcement	\$ 29.50	1						4	4	8	416	\$ 50.08	\$ 400.64	\$ 20,833.28
<b>Total</b>			<b>3</b>	<b>16</b>	<b>16</b>	<b>16</b>	<b>16</b>	<b>16</b>	<b>4</b>	<b>4</b>	<b>128</b>	<b>6656</b>	<b>\$ -</b>	<b>\$ 5,343.84</b>	<b>\$ 277,879.68</b>
Contingencies (percentage to be determined by Contractor)														\$ 6,752.00	
<b>Annual Amount Not to Exceed</b>															<b>\$ 284,631.68</b>

Year 2															
Positions Classification	Job Duties	Labor Rate	Number of Staff	Daily Service Hours							Weekly	Total Annual Hours (52 weeks)	Hourly Billing Rate (Regular)	Post Coverage	
				Mon.	Tues.	Wed.	Thurs.	Fri.	Sat.	Sun.	Total Hours per Week			Weekly Cost	Annual Cost
Senior Parking Enforcement (Day)	Parking Enforcement & Supervision	\$ 23.75	1	8	8	8	8	8			40	2080	\$ 42.90	\$ 1,716.00	\$ 89,232.00
Senior Parking Enforcement (Grave)	Parking Enforcement & Supervision	\$ 27.25	-								0	0	\$ 49.43	\$ -	\$ -
Parking Enforcement (Grave)	Parking Enforcement	\$ 25.25	2	16	16	16	16	16			80	4160	\$ 46.21	\$ 3,696.80	\$ 192,233.60
Parking Enforcement Weekend (Grave)	Parking Enforcement	\$ 30.25	1						4	4	8	416	\$ 54.84	\$ 438.72	\$ 22,813.44
<b>Total</b>			<b>3</b>	<b>16</b>	<b>16</b>	<b>16</b>	<b>16</b>	<b>16</b>	<b>4</b>	<b>4</b>	<b>128</b>	<b>6656</b>	<b>\$ -</b>	<b>\$ 5,851.52</b>	<b>\$ 304,279.04</b>
Contingencies (percentage to be determined by Contractor)														\$ 7,393.60	
<b>Annual Amount Not to Exceed</b>															<b>\$ 311,672.64</b>

Year 3															
Positions Classification	Job Duties	Labor Rate	Number of Staff	Daily Service Hours							Weekly	Total Annual Hours (52 weeks)	Hourly Billing Rate (Regular)	Post Coverage	
				Mon.	Tues.	Wed.	Thurs.	Fri.	Sat.	Sun.	Total Hours per Week			Weekly Cost	Annual Cost
Senior Parking Enforcement (Day)	Parking Enforcement & Supervision	\$ 24.50	1	8	8	8	8	8			40	2080	\$ 48.98	\$ 1,879.20	\$ 97,718.40
Senior Parking Enforcement (Grave)	Parking Enforcement & Supervision	\$ 28.00	-								0	0	\$ 54.13	\$ -	\$ -
Parking Enforcement (Grave)	Parking Enforcement	\$ 26.00	2	16	16	16	16	16			80	4160	\$ 50.60	\$ 4,048.00	\$ 210,496.00
Parking Enforcement Weekend (Grave)	Parking Enforcement	\$ 31.00	1						4	4	8	416	\$ 60.05	\$ 480.40	\$ 24,980.80
<b>Total</b>			<b>3</b>	<b>16</b>	<b>16</b>	<b>16</b>	<b>16</b>	<b>16</b>	<b>4</b>	<b>4</b>	<b>128</b>	<b>6656</b>	<b>\$ -</b>	<b>\$ 6,407.60</b>	<b>\$ 333,195.20</b>
Contingencies (percentage to be determined by Contractor)														\$ 8,096.00	
<b>Annual Amount Not to Exceed</b>															<b>\$ 341,291.20</b>

**Grand Total 3-Year Cost** **\$ 937,595.52**

Prepared by: Danny Chung  
Name: Danny Chung  
Title: Junior Pricing Analyst

**CITY OF ARCADIA  
PROFESSIONAL SERVICES AGREEMENT REGARDING  
OFFICIAL PARKING ENFORCEMENT SERVICES**

This Agreement is made and entered into as of \_\_\_\_\_, 20\_\_ by and between the City of Arcadia, a municipal corporation organized and operating under the laws of the State of California with its principal place of business at 240 West Huntington Drive, Arcadia, California 91066 ("City"), and Inter-Con Security, a corporation with its principal place of business at 210 South De Lacey Avenue, Pasadena, CA 91105 (hereinafter referred to as "Consultant"). City and Consultant are sometimes individually referred to as "Party" and collectively as "Parties" in this Agreement.

**RECITALS**

A. City is a public agency of the State of California and is in need of professional services for the following project:

Official Parking Enforcement Services (hereinafter referred to as "the Project").

B. Consultant is duly licensed and has the necessary qualifications to provide such services.

C. The Parties desire by this Agreement to establish the terms for City to retain Consultant to provide the services described herein.

**AGREEMENT**

**NOW, THEREFORE, IT IS AGREED AS FOLLOWS:**

1. Services.

Consultant shall provide the City with the services described in the Scope of Services attached hereto as Exhibit "A."

2. Compensation.

a. Subject to paragraph 2(b) below, the City shall pay for such services in accordance with the Schedule of Charges set forth in Exhibit "B."

b. In no event except for the terms outlined in Exhibit "B" shall the total amount paid for services rendered by Consultant under this Agreement exceed the sum of nine hundred thirty-seven, five hundred ninety-six dollars and zero cents **[\$937,596]** for the initial three year term. This amount is to cover all printing and related costs, and the City will not pay any additional fees for printing expenses. Periodic payments shall be made within

30 days of receipt of an invoice which includes a detailed description of the work performed. Payments to Consultant for work performed will be made on a monthly billing basis.

3. Additional Work.

If changes in the work seem merited by Consultant or the City, and informal consultations with the other party indicate that a change is warranted, it shall be processed in the following manner: a letter outlining the changes shall be forwarded to the City by Consultant with a statement of estimated changes in fee or time schedule. An amendment to this Agreement shall be prepared by the City and executed by both Parties before performance of such services, or the City will not be required to pay for the changes in the scope of work. Such amendment shall not render ineffective or invalidate unaffected portions of this Agreement.

4. Maintenance of Records.

Books, documents, papers, accounting records, and other evidence pertaining to costs incurred shall be maintained by Consultant and made available at all reasonable times during the contract period and for four (4) years from the date of final payment under the contract for inspection by City.

5. Term.

The term of this Agreement shall be from **July 1, 2026, to June 30, 2029, with the option of three, one-year renewals** unless earlier terminated as provided herein. The Parties may, by mutual, written consent, extend the term of this Agreement if necessary to complete the Project. Consultant shall perform its services in a prompt and timely manner within the term of this Agreement and shall commence performance upon receipt of written notice from the City to proceed ("Notice to Proceed"). The Notice to Proceed shall set forth the date of commencement of work.

6. Delays in Performance.

a. Neither City nor Consultant shall be considered in default of this Agreement for delays in performance caused by circumstances beyond the reasonable control of the non-performing party. For purposes of this Agreement, such circumstances include but are not limited to, abnormal weather conditions; floods; earthquakes; fire; epidemics; war; riots and other civil disturbances; strikes, lockouts, work slowdowns, and other labor disturbances; sabotage or judicial restraint.

b. Should such circumstances occur, the non-performing party shall, within a reasonable time of being prevented from performing, give written notice to the other party describing the circumstances preventing continued performance and the efforts being made to resume performance of this Agreement.

7. Compliance with Law.

a. Consultant shall comply with all applicable laws, ordinances, codes and regulations of the federal, state and local government, including Cal/OSHA requirements.

b. If required, Consultant shall assist the City, as requested, in obtaining and maintaining all permits required of Consultant by federal, state and local regulatory agencies.

c. If applicable, Consultant is responsible for all costs of clean up and/ or removal of hazardous and toxic substances spilled as a result of his or her services or operations performed under this Agreement.

8. Standard of Care

Consultant's services will be performed in accordance with generally accepted professional practices and principles and in a manner consistent with the level of care and skill ordinarily exercised by members of the profession currently practicing under similar conditions.

9. Assignment and Subconsultant

Consultant shall not assign, sublet, or transfer this Agreement or any rights under or interest in this Agreement without the written consent of the City, which may be withheld for any reason. Any attempt to so assign or so transfer without such consent shall be void and without legal effect and shall constitute grounds for termination. Subcontracts, if any, shall contain a provision making them subject to all provisions stipulated in this Agreement. Nothing contained herein shall prevent Consultant from employing independent associates, and subconsultants as Consultant may deem appropriate to assist in the performance of services hereunder.

10. Independent Contractor

Consultant is retained as an independent contractor and is not an employee of City. No employee or agent of Consultant shall become an employee of City. The work to be performed shall be in accordance with the work described in this Agreement, subject to such directions and amendments from City as herein provided.

11. Insurance. Consultant shall not commence work for the City until it has provided evidence satisfactory to the City it has secured all insurance required under this section. In addition, Consultant shall not allow any subcontractor to commence work on any subcontract until it has secured all insurance required under this section.

a. Commercial General Liability

(i) The Consultant shall take out and maintain, during the performance of all work under this Agreement, in amounts not less than specified herein, Commercial General Liability Insurance, in a form and with insurance companies acceptable to the City.

(ii) Coverage for Commercial General Liability insurance shall be at least as broad as the following:

(1) Insurance Services Office Commercial General Liability coverage (Occurrence Form CG 00 01) or exact equivalent.

(iii) Commercial General Liability Insurance must include coverage for the following:

- (1) Bodily Injury and Property Damage
- (2) Personal Injury/Advertising Injury
- (3) Premises/Operations Liability
- (4) Products/Completed Operations Liability **Consultant shall procure and submit evidence of insurance for at least five (5) years from the time that all work under this Agreement is completed.**
- (5) Aggregate Limits that Apply per Project
- (6) Explosion, Collapse and Underground (UCX) exclusion deleted
- (7) Contractual Liability with respect to this Agreement
- (8) Property Damage
- (9) Independent Consultants Coverage

(iv) The policy shall contain no endorsements or provisions limiting coverage for (1) contractual liability; (2) cross liability exclusion for claims or suits by one insured against another; (3) products/completed operations liability; or (4) contain any other exclusion contrary to the Agreement.

(v) The policy shall give City, its officials, officers, employees, agents and City designated volunteers additional insured status using ISO endorsement forms CG 20 10 10 01 and 20 37 10 01, or endorsements providing the exact same coverage. Consultant may provide blanket endorsements to meet the Additional Insured requirement in this written contract. However, all subcontractors' endorsements shall specifically name the City, its elected officials, officers, employees, volunteers, boards, agents, and representatives as additional insureds and blanket endorsements are not acceptable.

(vi) The general liability program may utilize either deductibles or provide coverage excess of a self-insured retention, subject to written approval by the City, and provided that such deductibles shall not apply to the City as an additional insured.

b. Automobile Liability

(i) At all times during the performance of the work under this Agreement, the Consultant shall maintain Automobile Liability Insurance for bodily injury and property damage including coverage for owned, non-owned and hired vehicles, in a form and with insurance companies acceptable to the City.

(ii) Coverage for automobile liability insurance shall be at least as broad as Insurance Services Office Form Number CA 00 01 covering automobile liability (Coverage Symbol 1, any auto).

(iii) The policy shall give City, its officials, officers, employees, agents and City designated volunteers additional insured status. Consultant may provide blanket endorsements to meet the Additional Insured requirement in this written contract. However, all subcontractors' endorsements shall specifically name the City, its elected officials, officers, employees, volunteers, boards, agents, and representatives as additional insureds and blanket endorsements are not acceptable.

(iv) Subject to written approval by the City, the automobile liability program may utilize deductibles, provided that such deductibles shall not apply to the City as an additional insured, but not a self-insured retention.

c. Workers' Compensation/Employer's Liability

(i) Consultant certifies that he/she is aware of the provisions of Section 3700 of the California Labor Code which requires every employer to be insured against liability for workers' compensation or to undertake self-insurance in accordance with the provisions of that code, and he/she will comply with such provisions before commencing work under this Agreement.

(ii) To the extent Consultant has employees at any time during the term of this Agreement, at all times during the performance of the work under this Agreement, the Consultant shall maintain full compensation insurance for all persons employed directly by him/her to carry out the work contemplated under this Agreement, all in accordance with the "Workers' Compensation and Insurance Act," Division IV of the Labor Code of the State of California and any acts amendatory thereof, and Employer's Liability Coverage in amounts indicated herein. Consultant shall require all subconsultants to obtain and maintain, for the period required by this Agreement, workers' compensation coverage of the same type and limits as specified in this section.

d. Professional Liability (Errors and Omissions)

At all times during the performance of the work under this Agreement the Consultant shall maintain professional liability or Errors and Omissions insurance appropriate to its

profession, in a form and with insurance companies acceptable to the City and in an amount indicated herein. This insurance shall be endorsed to include contractual liability applicable to this Agreement and shall be written on a policy form coverage specifically designed to protect against acts, errors or omissions of the Consultant. "Covered Professional Services" as designated in the policy must specifically include work performed under this Agreement. The policy must "pay on behalf of" the insured and must include a provision establishing the insurer's duty to defend.

e. Minimum Policy Limits Required

(i) The following insurance limits are required for the Agreement:

Combined Single Limit

Commercial General Liability	\$1,000,000 per occurrence/ \$2,000,000 aggregate for bodily injury, personal injury, and property damage
Automobile Liability	\$1,000,000 per occurrence for bodily injury and property damage
Employer's Liability	\$1,000,000 per occurrence
Professional Liability	\$1,000,000 per claim and aggregate (errors and omissions)

(ii) Defense costs shall be payable in addition to the limits.

(iii) Requirements of specific coverage or limits contained in this section are not intended as a limitation on coverage, limits, or other requirement, or a waiver of any coverage normally provided by any insurance. Any available coverage shall be provided to the parties required to be named as Additional Insured pursuant to this Agreement.

f. Evidence Required

Prior to execution of the Agreement, the Consultant shall file with the City evidence of insurance from an insurer or insurers certifying to the coverage of all insurance required herein. Such evidence shall include original copies of the ISO CG 00 01 (or insurer's equivalent) signed by the insurer's representative and Certificate of Insurance (Acord Form 25-S or equivalent), together with required endorsements. All evidence of insurance shall be signed by a properly authorized officer, agent, or qualified representative of the insurer and shall certify the names of the insured, any additional insureds, where appropriate, the type and amount of the insurance, the location and operations to which the insurance applies, and the expiration date of such insurance.

g. Policy Provisions Required

(i) Consultant shall provide the City at least thirty (30) days prior written notice of cancellation of any policy required by this Agreement, except that the Consultant shall provide at least ten (10) days prior written notice of cancellation of any such policy due to non-payment of premium. If any of the required coverage is cancelled or expires during the term of this Agreement, the Consultant shall deliver renewal certificate(s) including the General Liability Additional Insured Endorsement to the City at least ten (10) days prior to the effective date of cancellation or expiration. Consultant may provide blanket endorsements to meet the Additional Insured requirement in this written contract. However, all subcontractors' endorsements shall specifically name the City, its elected officials, officers, employees, volunteers, boards, agents, and representatives as additional insureds and blanket endorsements are not acceptable.

(ii) The Commercial General Liability Policy and Automobile Policy shall each contain a provision stating that Consultant's policy is primary insurance and that any insurance, self-insurance or other coverage maintained by the City or any named insureds shall not be called upon to contribute to any loss.

(iii) The retroactive date (if any) of each policy is to be no later than the effective date of this Agreement. Consultant shall maintain such coverage continuously for a period of at least three years after the completion of the work under this Agreement. Consultant shall purchase a one (1) year extended reporting period A) if the retroactive date is advanced past the effective date of this Agreement; B) if the policy is cancelled or not renewed; or C) if the policy is replaced by another claims-made policy with a retroactive date subsequent to the effective date of this Agreement.

(iv) All required insurance coverages, except for the professional liability coverage, shall contain or be endorsed to waiver of subrogation in favor of the City, its officials, officers, employees, agents, and volunteers or shall specifically allow Consultant or others providing insurance evidence in compliance with these specifications to waive their right of recovery prior to a loss. Consultant hereby waives its own right of recovery against City, and shall require similar written express waivers and insurance clauses from each of its subconsultants.

(v) The limits set forth herein shall apply separately to each insured against whom claims are made or suits are brought, except with respect to the limits of liability. Further the limits set forth herein shall not be construed to relieve the Consultant from liability in excess of such coverage, nor shall it limit the Consultant's indemnification obligations to the City and shall not preclude the City from taking such other actions available to the City under other provisions of the Agreement or law.

h. Qualifying Insurers

(i) All policies required shall be issued by acceptable insurance companies, as determined by the City, which satisfy the following minimum requirements:

(1) Each such policy shall be from a company or companies with a current A.M. Best's rating of no less than A:VII and admitted to transact in the business of insurance in the State of California, or otherwise allowed to place insurance through surplus line brokers under applicable provisions of the California Insurance Code or any federal law.

i. Additional Insurance Provisions

(i) The foregoing requirements as to the types and limits of insurance coverage to be maintained by Consultant, and any approval of said insurance by the City, is not intended to and shall not in any manner limit or qualify the liabilities and obligations otherwise assumed by the Consultant pursuant to this Agreement, including but not limited to, the provisions concerning indemnification.

(ii) If at any time during the life of the Agreement, any policy of insurance required under this Agreement does not comply with these specifications or is canceled and not replaced, City has the right but not the duty to obtain the insurance it deems necessary and any premium paid by City will be promptly reimbursed by Consultant or City will withhold amounts sufficient to pay premium from Consultant payments. In the alternative, City may cancel this Agreement.

(iii) The City may require the Consultant to provide complete copies of all insurance policies in effect for the duration of the Project.

(iv) Neither the City nor any of its officials, officers, employees, agents or volunteers shall be personally responsible for any liability arising under or by virtue of this Agreement.

j. Subconsultant Insurance Requirements. Consultant shall not allow any subcontractors or subconsultants to commence work on any subcontract until they have provided evidence satisfactory to the City that they have secured all insurance required under this section. Policies of commercial general liability insurance provided by such subcontractors or subconsultants shall be endorsed to name the City as an additional insured using ISO form CG 20 38 04 13 or an endorsement providing the exact same coverage. All subcontractors' endorsements shall specifically name the City, its elected officials, officers, employees, volunteers, boards, agents, and representatives as additional insureds and blanket endorsements are not acceptable. If requested by Consultant, City may approve different scopes or minimum limits of insurance for particular subcontractors or subconsultants.

12. Indemnification.

a. To the fullest extent permitted by law, Consultant shall defend (with counsel of City's choosing), indemnify and hold the City, its officials, officers, employees, volunteers, and agents free and harmless from any and all claims, demands, causes of action, costs, expenses, liability, loss, damage or injury of any kind, in law or equity, to property or persons, including wrongful death, in any manner arising out of, pertaining to, or incident to any acts, errors or omissions, or willful misconduct of Consultant, its officials, officers, employees, subcontractors, consultants or agents in connection with the performance of the Consultant's services, the Project or this Agreement, including without limitation the payment of all damages, expert witness fees and attorney's fees and other related costs and expenses. Consultant's obligation to indemnify shall not be restricted to insurance proceeds, if any, received by Consultant, the City, its officials, officers, employees, agents, or volunteers.

b. To the extent required by Civil Code section 2782.8, which is fully incorporated herein, Consultant's obligations under the above indemnity shall be limited to claims that arise out of, pertain to, or relate to the negligence, recklessness, or willful misconduct of the Consultant, but shall not otherwise be reduced. If Consultant's obligations to defend, indemnify, and/or hold harmless arise out of Consultant's performance of "design professional services" (as that term is defined under Civil Code section 2782.8), then upon Consultant obtaining a final adjudication that liability under a claim is caused by the comparative active negligence or willful misconduct of the City, Consultant's obligations shall be reduced in proportion to the established comparative liability of the City and shall not exceed the Consultant's proportionate percentage of fault.

### 13. California Labor Code Requirements.

a. Consultant is aware of the requirements of California Labor Code Sections 1720 et seq. and 1770 et seq., which require the payment of prevailing wage rates and the performance of other requirements on certain "public works" and "maintenance" projects ("Prevailing Wage Laws"). If the services are being performed as part of an applicable "public works" or "maintenance" project, as defined by the Prevailing Wage Laws, and if the total compensation is \$15,000 or more for maintenance or \$25,000 or more for construction, alteration, demolition, installation, or repair, Consultant agrees to fully comply with such Prevailing Wage Laws. Consultant shall defend, indemnify and hold the City, its officials, officers, employees and agents free and harmless from any claims, liabilities, costs, penalties or interest arising out of any failure or alleged failure to comply with the Prevailing Wage Laws. It shall be mandatory upon the Consultant and all subconsultants to comply with all California Labor Code provisions, which include but are not limited to prevailing wages (Labor Code Sections 1771, 1774 and 1775), employment of apprentices (Labor Code Section 1777.5), certified payroll records (Labor Code Sections 1771.4 and 1776), hours of labor (Labor Code Sections 1813 and 1815) and debarment of contractors and subcontractors (Labor Code Section 1777.1).

b. If the services are being performed as part of an applicable “public works” or “maintenance” project and if the total compensation is \$15,000 or more for maintenance or \$25,000 or more for construction, alteration, demolition, installation, or repair, then pursuant to Labor Code Sections 1725.5 and 1771.1, the Consultant and all subconsultants performing such services must be registered with the Department of Industrial Relations. Consultant shall maintain registration for the duration of the Project and require the same of any subconsultants, as applicable. This Project may also be subject to compliance monitoring and enforcement by the Department of Industrial Relations. It shall be Consultant’s sole responsibility to comply with all applicable registration and labor compliance requirements.

c. This Agreement may also be subject to compliance monitoring and enforcement by the Department of Industrial Relations. It shall be Consultant’s sole responsibility to comply with all applicable registration and labor compliance requirements. Any stop orders issued by the Department of Industrial Relations against Consultant or any subcontractor that affect Consultant’s performance of services, including any delay, shall be Consultant’s sole responsibility. Any delay arising out of or resulting from such stop orders shall be considered Consultant caused delay and shall not be compensable by the City. Consultant shall defend, indemnify and hold the City, its officials, officers, employees and agents free and harmless from any claim or liability arising out of stop orders issued by the Department of Industrial Relations against Consultant or any subcontractor.

14. Verification of Employment Eligibility.

By executing this Agreement, Consultant verifies that it fully complies with all requirements and restrictions of state and federal law respecting the employment of undocumented aliens, including, but not limited to, the Immigration Reform and Control Act of 1986, as may be amended from time to time, and shall require all subconsultants and sub-subconsultants to comply with the same.

re deemed to be a part of this Agreement.

15. Laws and Venue.

This Agreement shall be interpreted in accordance with the laws of the State of California. If any action is brought to interpret or enforce any term of this Agreement, the action shall be brought in a state or federal court situated in the County of Los Angeles, State of California.

16. Termination or Abandonment

a. City has the right to terminate or abandon any portion or all of the work under this Agreement by giving ten (10) calendar days written notice to Consultant. In such event, City shall be immediately given title and possession to all original field notes, drawings and specifications, written reports and other documents produced or developed for that

portion of the work completed and/or being abandoned. City shall pay Consultant the reasonable value of services rendered for any portion of the work completed prior to termination. If said termination occurs prior to completion of any task for the Project for which a payment request has not been received, the charge for services performed during such task shall be the reasonable value of such services, based on an amount mutually agreed to by City and Consultant of the portion of such task completed but not paid prior to said termination. City shall not be liable for any costs other than the charges or portions thereof which are specified herein. Consultant shall not be entitled to payment for unperformed services, and shall not be entitled to damages or compensation for termination of work.

b. Consultant may terminate its obligation to provide further services under this Agreement upon thirty (30) calendar days' written notice to City only in the event of substantial failure by City to perform in accordance with the terms of this Agreement through no fault of Consultant.

18 Documents. Except as otherwise provided in "Termination or Abandonment," above, all original field notes, written reports, Drawings and Specifications and other documents, produced or developed for the Project shall, upon payment in full for the services described in this Agreement, be furnished to and become the property of the City.

19. Organization

Consultant shall assign John Campbell, SVP, as Project Manager. The Project Manager shall not be removed from the Project or reassigned without the prior written consent of the City.

20. Limitation of Agreement.

This Agreement is limited to and includes only the work included in the Project described above.

21. Notice

Any notice or instrument required to be given or delivered by this Agreement may be given or delivered by depositing the same in any United States Post Office, certified mail, return receipt requested, postage prepaid, addressed to:

CITY:

City of Arcadia

240 West Huntington Drive

Arcadia, CA 91066

CONSULTANT:

Inter-Con Security

210 South De Lacey Avenue

Pasadena, CA 91105

Attn: Captain Kollin Cieadlo, Arcadia Police Attn: John Campbell, SVP  
Department

and shall be effective upon receipt thereof.

22. Third Party Rights

Nothing in this Agreement shall be construed to give any rights or benefits to anyone other than the City and the Consultant.

23. Equal Opportunity Employment.

Consultant represents that it is an equal opportunity employer and that it shall not discriminate against any employee or applicant for employment because of race, religion, color, national origin, ancestry, sex, age or other interests protected by the State or Federal Constitutions. Such non-discrimination shall include, but not be limited to, all activities related to initial employment, upgrading, demotion, transfer, recruitment or recruitment advertising, layoff or termination.

24. Entire Agreement

This Agreement, with its exhibits, represents the entire understanding of City and Consultant as to those matters contained herein, and supersedes and cancels any prior or contemporaneous oral or written understanding, promises or representations with respect to those matters covered hereunder. Each party acknowledges that no representations, inducements, promises or agreements have been made by any person which are not incorporated herein, and that any other agreements shall be void. This Agreement may not be modified or altered except in writing signed by both Parties hereto. This is an integrated Agreement.

25. Severability

The unenforceability, invalidity or illegality of any provision(s) of this Agreement shall not render the provisions unenforceable, invalid or illegal.

26. Successors and Assigns

This Agreement shall be binding upon and shall inure to the benefit of the successors in interest, executors, administrators and assigns of each party to this Agreement. However, Consultant shall not assign or transfer by operation of law or otherwise any or all of its rights, burdens, duties or obligations without the prior written consent of City. Any attempted assignment without such consent shall be invalid and void.

27. Non-Waiver

None of the provisions of this Agreement shall be considered waived by either party, unless such waiver is specifically specified in writing.

28. Time of Essence

Time is of the essence for each and every provision of this Agreement.

29. City's Right to Employ Other Consultants

City reserves its right to employ other consultants, including engineers, in connection with this Project or other projects.

30. Prohibited Interests

Consultant maintains and warrants that it has not employed nor retained any company or person, other than a bona fide employee working solely for Consultant, to solicit or secure this Agreement. Further, Consultant warrants that it has not paid nor has it agreed to pay any company or person, other than a bona fide employee working solely for Consultant, any fee, commission, percentage, brokerage fee, gift or other consideration contingent upon or resulting from the award or making of this Agreement. For breach or violation of this warranty, City shall have the right to rescind this Agreement without liability. For the term of this Agreement, no director, official, officer or employee of City, during the term of his or her service with City, shall have any direct interest in this Agreement, or obtain any present or anticipated material benefit arising therefrom.

**[SIGNATURES ON FOLLOWING PAGE]**

**SIGNATURE PAGE FOR PROFESSIONAL SERVICES AGREEMENT  
BETWEEN THE CITY OF ARCADIA  
AND INTER-CON SECURITY**

IN WITNESS WHEREOF, the Parties have executed this Agreement as of the date first written above.

CITY OF ARCADIA

INTER-CON SECURITY

By: \_\_\_\_\_  
Dominic Lazzaretto  
City Manager

By: \_\_\_\_\_  
Thomas Rath  
Assistant General Counsel

Date: \_\_\_\_\_

Date: \_\_\_\_\_

ATTEST:

By: \_\_\_\_\_  
Robert Ray  
General Counsel

By: \_\_\_\_\_  
City Clerk

Date: \_\_\_\_\_

APPROVED AS TO FORM

CONCUR:

By: \_\_\_\_\_  
Michael J. Maurer  
City Attorney

\_\_\_\_\_  
Roy Nakamura  
Chief of Police

## EXHIBIT A

### Scope of Services

Consultant shall provide parking enforcement services according to the following minimum specifications:

#### **Regular Duty.**

1. Patrol City streets, City facilities, recreational areas, and any private locations via motor vehicles, bicycles, or on foot, designated routes and staggered-time schedules, with primary responsibility of enforcing City, State, and Federal parking laws and regulations, and perform duties as directed by a police supervisor.
2. If bicycle patrol was necessary at some point during the term of the Agreement, it is the responsibility of the Contractor to furnish and maintain bicycles for use by Contract employees. Bicycles shall be considered an add-on cost, and the Agreement cost will be adjusted if the City ever requests this service
3. Issue parking citations for vehicles in violation of City, State, and Federal parking laws and services. Both the California Vehicle Code (CVC) and the Arcadia Municipal Code (AMC) will be used as the basis for issuing citations in the City.
2. Assist with the enforcement of private property parking regulations, enforcement of regulations in parking facilities, and assisting with public service (as needed).
3. Provide customer service as needed to give directions, information, phone numbers, etc.
4. Participate in any hearing processes or subsequent process involving a contested or challenged parking citation or incident involving assigned parking enforcement representatives.
5. **Scofflaw Detail.** Locate and report to designated City staff vehicles that are subject to being impounded or immobilized as a result of the vehicles having a specified number of delinquent parking citations and/or for any other vehicle subject to towing under the vehicle code or local ordinances.
6. Related Activities. Report to designated City staff any unlawful act of any condition or deficiency which may pose a hazard or danger to the general public.

**Personnel Selection.** Contractor is wholly responsible for the supervision of contract employees and administration of the Agreement to the satisfaction of the City. Contractor shall be responsible for providing competent personnel to assist the City to enforce its parking regulations. Contractor shall be solely responsible for selecting, hiring, employing, paying, supervising, training, and discharging its personnel. Additionally, Contractor must ensure staffing to ensure all posts are filled, complete performance evaluation of contract employees, conduct disciplinary action against contract employees, and handle processing for all payroll and benefits allowances for its employees. Contractor shall provide personnel who meet the following minimum criteria:

1. Education. Each contract employee shall have a high school education or equivalent (GED certificate).
2. Skill. Each contract employee shall be able to read, write, and speak the English language and must be able to write intelligible reports.
3. Experience. Each contract employee shall have experience with similar types of parking enforcement methods used by the City and shall have expertise in the management of parking enforcement duties in a market similar to the market in which the subject duties are located.
4. Other Qualifications. Each contract employee:
  - a. Must be at least eighteen (18) years of age.
  - b. Must be physically and mentally capable of performing parking enforcement duties.
  - c. Must be neat and well groomed.
  - d. Must have the ability to give and follow oral and written instructions in the English language.
  - e. Must have the ability to establish and maintain effective working relationships with the public and City personnel.
  - f. Must have a valid California State driver's license.
  - g. Must be in possession of valid permits, licenses, and certifications required for the performance of job-related duties.

- h. Must be able to legally, safely, and properly operate necessary computer databases, equipment, and tools.
- i. Must have the ability to operate motor vehicles and walk for several hours or distances.
- j. Must have taken and passed a developed reference check, a drug screening test, and undergone a medical examination to determine fitness to perform assigned duties.
- k. Must have undergone a criminal history check in order to determine that contract employee possesses no felony criminal convictions. Misdemeanor criminal convictions will be reviewed by the City on a case by case basis for acceptability.
- l. Must have the ability to remain calm and use good judgment and initiative in a confrontational or emergency situation. Shall be capable of acting in the utmost professional manner when interacting with customers and the general public.

**Professional Behavior.**

1. Contractor shall be responsible for the conduct, demeanor and appearance of its employees while in the City or while acting in the course and scope of employment.
2. While in the City or while acting in the course and scope of employment, all employees of the Contractor shall be neat and clean and shall act in a courteous and professional manner. No employee shall use improper language or act in a loud, offensive or otherwise improper manner.
3. Contract employees are trained as to the purpose of their positions and the importance of performing their job duties according to the City's operating instructions.
4. All contract employees shall at all times be polite and courteous in their dealings with customers, treating the public with care and respect.
5. All contract employees are to be attentive, alert and responsive to all customer issues, needs, comments or complaints.
6. All contract employees must speak clearly and in a professional manner while interacting with customers or offering the assistance needed by each customer.

## **Job Classifications and Duties of Employees.**

1. Contractor must provide the classifications of all employee positions as well as job description duties for each position. Classifications might include, but are not limited to:

- a. Senior/Supervisor Parking Enforcement Representative: Assist the parking enforcement staff in day-to-day operations and staffing issues. The Supervisor shall be subject to the approval of the Chief of Police, or his designee.

During the hours that the Supervisor is managing, supervising, and operating the parking enforcement, he/she shall not simultaneously be responsible for managing, supervising or operating any other non-City operations.

- b. Parking Enforcement Representative: Responsible for the day-to-day management, supervision, and operation of all City-wide parking enforcement.

## **Staffing Levels and Work Schedules.**

1. Contractor shall be responsible for providing an adequate number of trained and bonded personnel, as determined by the Chief of Police, or his designee.
2. Contractor shall employ at least one (1) supervisory level employee with decision-making authority for this project.
3. Contractor shall ensure that at least one (1) supervisory level employee having decision-making authority regarding parking enforcement operation and management is available to the City by mobile phone twenty-four (24) hours a day, seven (7) days a week.
4. An average of one hundred twenty (120) hours of parking enforcement per week and eight (8) hours of parking enforcement per weekend shall be performed by contract employees. The total number of average hours is equal to one hundred sixty-eight (128) hours.

Contractor will staff on/off-street parking enforcement and maintain enforcement hours pursuant to the following:

1. On-Street Enforcement

- a. Enforcement hours to be performed during peak parking and collection demand times in concert with City direction.
- b. Minimum of one (1) weekday early shift beginning at 2:00 AM per month.  
  
Shift Example: 2:00 AM – 10:00 AM (8 hours)
- c. Minimum of two (2) weekday late shifts ending at 6:00 PM per month.  
  
Shift Example: 10:00 AM – 6:00 PM (8 hours)
- d. Minimum of two (2) weekend overnight shifts per month (one person on Saturday and one person on Sunday) It shall be up to the discretion of the Contractor to determine if weekend contract employees are full-time or part-time status.
- e. No overtime rates will be honored for weekend shifts worked by full-time Senior Parking Enforcement Representative or full-time Parking Enforcement Representatives
- f. Shift Example: 2:00 AM – 6:00 AM (4 hours)

2. Off-Street Enforcement

- a. Enforcement of each off-street parking location every day.
- b. Enforcement seven (7) days per week per the Chief of Police or his designee.
- c. Contractor shall be responsible for making available for participation in a hearing process any contract employee who issued a parking citation which is being contested or challenged. All work schedules and additional details shall be arranged with and approved by the Chief of Police, or his designee.
- d. The Chief of Police, or his designee, maintains approval rights for the appointing of all parking enforcement positions. The City reserves the right to request that an employee be replaced at any time without cause.

## **Training.**

1. Contractor shall provide training programs for all regular and replacement contract employees who work in the City, in their respective scope of job duties. Additionally, and as needed, Contractor shall provide retraining and continuing education for contract employees.
2. Contractor shall train all of its employees prior to being assigned for service in the City.
3. The initial training shall be in the form of an employee orientation lasting no less than eight (8) hours. The employee(s) shall complete this training within ten (10) days of their hire date. Contractor shall notify the City of completion of said completion.
4. Training shall be comprehensive and include information on topics including but not limited to:
  - a. General parking enforcement programs and duties.
  - b. California Vehicle Code (CVC), Arcadia Municipal Code (AMC) and ordinances related to parking enforcement.
  - c. Specific policies and procedures adopted by the City.
  - d. Customer service and expectations.
  - e. Ethnic sensitivity training.
  - f. Dealing with persons with disabilities and the Americans with Disabilities Act of 1990.
  - g. Dealing with difficult people.
  - h. Conflict Management and dispute resolution.
  - i. Civil rights laws and procedures.
  - j. Giving testimony and courtroom and hearing procedures.
  - k. Job procedures and emergency protocols.
  - l. Job safety as required by OSHA/WISHA.

m. Public Safety.

5. Training shall include instruction on communications procedures, on hearing officer presentations, the proper and acceptable use of all parking enforcement equipment, including but not limited to transportation vehicles, radios, public relations and conflict mitigation techniques, and citation devices if available.
6. Contractor shall submit a copy of its Employee Training Manual to the City within fourteen (14) calendar days after award of Professional Services Agreement for approval, in writing, to the Chief of Police or his designee.
7. A copy of the written training procedures for all employee classifications shall be submitted for review and approval to the Chief of Police, or his designee. The City retains the right to amend any contract employee's training program.
8. Contractor shall make necessary revisions to training on an as-needed basis, but at least on an annual basis, submitted to and approved, in writing, by the Chief of Police or his designee.
9. In addition to said training, Contractor will be responsible for all additional training beyond the 80-hours of job-specific training provided by and paid for by the City.

**Uniforms.**

1. Contractor will be responsible for providing contract employees with a conspicuous I.D. badge and distinct uniform that is proper, complete and acceptable. The Chief of Police, or his designee, shall approve any uniform and I.D. badge proposed by the Contractor.
2. Each contract employee shall receive two sets of uniforms per year. The uniforms must be replaced annually or on an as-needed basis.
3. Uniforms shall include name tag and "Arcadia Parking Enforcement" placed on the front and back of the uniforms.
4. The City retains the right to determine what is a proper, complete, and acceptable uniform. Uniform design must be approved by the City.
5. Contractor shall be responsible for making sure uniforms are complete, clean, pressed, and professional in appearance.

6. All contract employees are to be in complete uniforms at any time they are engaged in enforcement duties or appearing in court in matters relating to their employment with the City.
7. All contract employees must carry photo identification and a copy of their work identification while on duty.

**Equipment.** Contractor will be financially responsible for all lost or damaged City property (ticket holders, radios, and citation devices) that are issued to Contractor employees.

1. Vehicles. Contractor is responsible for supplying its transportation requirements including a minimum of two (2) regulatory vehicles for use in the performance of on-street enforcement duties.
  - a. Contractor shall pay for all associated vehicles costs including but not limited to gasoline and maintenance.
2. All vehicles used by Contractor in its performance of this Agreement shall:
  - a. Be clearly identified as performing parking enforcement.
  - b. Be operated at all times in compliance with all state and local motor vehicle laws.
  - c. Have a prominent sign on the rear of the vehicle warning of frequent stops.
  - d. Contractor is responsible for the cleanliness, repair, and replacement of all vehicles used in the performance of this Contract.
  - e. Contractor will provide the Chief of Police, or his designee with a set of spare keys of the vehicles assigned in the Contract.

**Reports.** Contractor will be responsible for providing a monthly summary of Contractor employee activities, including, but not limited to, total number of citations, total number of reports, total billable work hours, patrol hours, and non-patrol activities (hearing process).

**Other.** Contractor shall be responsible for assuring employee compliance with all laws and regulations, compliance for all employment related laws and regulations, responding to inspections/audits by regulatory agencies and the City, and will pay any fines or assessments levied by regulatory agencies.

EXHIBIT B

Schedule of Charges/Payments

The City will compensate the Consultant for the services rendered as outlined below, in accordance with the attached cost proposals from the Consultant:

The total cost for the initial three-year term shall not exceed nine hundred thirty-seven, five hundred ninety-six dollar and zero cents (\$937,596). The three-year breakdown is as follows and is outlined in the billable cost shown below.

<b>Year 1 (FY 2026-27)</b>	<b>Year 2 (FY 2027-28)</b>	<b>Year 3 (FY 2028-29)</b>
<b>\$284,631.68</b>	<b>\$311,672.64</b>	<b>\$341,291.20</b>

Thereafter, if the City extends the contract for additional years, Consultant will modify their rates to account for increases in inflation based on the local metropolitan area Consumer Price Index for Urban Consumers (CPI-U). The parties will review costs during the City's budget preparation process during the first quarter of 2029.

During the life of the contract, should any unforeseeable costs arise at any time such as, but not limited to, changes to Federal, state, or local taxes; Federal, state, or local minimum wage rates that exert severe compression against the consultants wage rate; or Federal, state, or local changes to regulations that affect overtime, paid time off, medical benefits, or sick leave, then Consultant will modify the rates that such unexpected and unknowable costs can be covered. Any such change in rates are subject to the review and approval of the Arcadia City Council.

City of Arcadia  
Request for Proposal - Official Parking Enforcement Services (OPES)

**Official Parking Enforcement Services  
Proposed Billable Costs**

Company Name: Inter-Con Security Systems, Inc.

Year 1																
Positions Classification	Job Duties	Labor Rate	Number of Staff	Daily Service Hours							Weekly Total Hours per Week	Total Annual Hours (52 weeks)	Hourly Billing Rate (Regular)	Post Coverage		
				Mon.	Tues.	Wed.	Thurs.	Fri.	Sat.	Sun.				Weekly Cost	Annual Cost	
Senior Parking Enforcement (Day)	Parking Enforcement & Supervision	\$ 23.00	1	8	8	8	8	8	8		40	2080	\$ 39.18	\$ 1,567.20	\$ 81,494.40	
Senior Parking Enforcement (Grave)	Parking Enforcement & Supervision	\$ 26.50	-								0	0	\$ 45.14	\$ -	\$ -	
Parking Enforcement (Grave)	Parking Enforcement	\$ 24.50	2	16	16	16	16	16	16		80	4160	\$ 42.20	\$ 3,376.00	\$ 175,552.00	
Parking Enforcement Weekend (Grave)	Parking Enforcement	\$ 29.50	1							4	4	8	\$ 50.08	\$ 400.64	\$ 20,833.28	
<b>Total</b>			<b>3</b>	<b>16</b>	<b>16</b>	<b>16</b>	<b>16</b>	<b>16</b>	<b>16</b>	<b>4</b>	<b>4</b>	<b>128</b>	<b>6656</b>	<b>\$ -</b>	<b>\$ 5,343.84</b>	<b>\$ 277,879.68</b>
Contingencies (percentage to be determined by Contractor)																
<b>Annual Amount Not to Exceed</b>																

Year 2																
Positions Classification	Job Duties	Labor Rate	Number of Staff	Daily Service Hours							Weekly Total Hours per Week	Total Annual Hours (52 weeks)	Hourly Billing Rate (Regular)	Post Coverage		
				Mon.	Tues.	Wed.	Thurs.	Fri.	Sat.	Sun.				Weekly Cost	Annual Cost	
Senior Parking Enforcement (Day)	Parking Enforcement & Supervision	\$ 23.75	1	8	8	8	8	8	8		40	2080	\$ 42.90	\$ 1,716.00	\$ 89,232.00	
Senior Parking Enforcement (Grave)	Parking Enforcement & Supervision	\$ 27.25	-								0	0	\$ 49.43	\$ -	\$ -	
Parking Enforcement (Grave)	Parking Enforcement	\$ 25.25	2	16	16	16	16	16	16		80	4160	\$ 46.21	\$ 3,696.80	\$ 192,233.60	
Parking Enforcement Weekend (Grave)	Parking Enforcement	\$ 30.25	1							4	4	8	\$ 54.84	\$ 438.72	\$ 22,813.44	
<b>Total</b>			<b>3</b>	<b>16</b>	<b>16</b>	<b>16</b>	<b>16</b>	<b>16</b>	<b>16</b>	<b>4</b>	<b>4</b>	<b>128</b>	<b>6656</b>	<b>\$ -</b>	<b>\$ 5,851.52</b>	<b>\$ 304,279.04</b>
Contingencies (percentage to be determined by Contractor)																
<b>Annual Amount Not to Exceed</b>																

Year 3																
Positions Classification	Job Duties	Labor Rate	Number of Staff	Daily Service Hours							Weekly Total Hours per Week	Total Annual Hours (52 weeks)	Hourly Billing Rate (Regular)	Post Coverage		
				Mon.	Tues.	Wed.	Thurs.	Fri.	Sat.	Sun.				Weekly Cost	Annual Cost	
Senior Parking Enforcement (Day)	Parking Enforcement & Supervision	\$ 24.50	1	8	8	8	8	8	8		40	2080	\$ 48.98	\$ 1,879.20	\$ 97,718.40	
Senior Parking Enforcement (Grave)	Parking Enforcement & Supervision	\$ 28.00	-								0	0	\$ 54.13	\$ -	\$ -	
Parking Enforcement (Grave)	Parking Enforcement	\$ 26.00	2	16	16	16	16	16	16		80	4160	\$ 50.60	\$ 4,048.00	\$ 210,496.00	
Parking Enforcement Weekend (Grave)	Parking Enforcement	\$ 31.00	1							4	4	8	\$ 60.05	\$ 480.40	\$ 24,980.80	
<b>Total</b>			<b>3</b>	<b>16</b>	<b>16</b>	<b>16</b>	<b>16</b>	<b>16</b>	<b>16</b>	<b>4</b>	<b>4</b>	<b>128</b>	<b>6656</b>	<b>\$ -</b>	<b>\$ 6,407.60</b>	<b>\$ 333,195.20</b>
Contingencies (percentage to be determined by Contractor)																
<b>Annual Amount Not to Exceed</b>																

**Grand Total 3-Year Cost** \$ 937,595.52

Prepared by: Danny Chung  
Name: Danny Chung  
Title: Junior Pricing Analyst

**EXHIBIT 3**

# Pricing Narrative – City of Arcadia

## Parking Enforcement

Inter-Con is pleased to present the following pricing for The City of Arcadia Parking Enforcement program and appreciates the opportunity of extending our partnership with the City of Arcadia. As the longstanding provider of the City’s parking enforcement program, we have structured our pricing around the current program with new requirements from the RFP.

Inter-Con’s pricing is structured to reflect the operational requirements, labor conditions, and service expectations associated with the RFP submitted by The City of Arcadia Parking Enforcement. The assumptions outlined below form the basis of the proposed rates and are critical to ensuring accurate and sustainable pricing over the contract term. Inter-Con is willing to evaluate and revise cost assumptions as requested by the City; however, such changes may result in adjustments to the proposed bill rates to ensure alignment with the updated scope and requirements. As a client-focused organization, Inter-Con continually strives to deliver best-in-class security services while maintaining transparency and partnership in all aspects of program delivery, including pricing. We remain open and flexible in working collaboratively with the City to review assumptions, address program needs, and ensure the pricing structure supports the long-term success of the security program.

### **PROPOSAL REVISION**

Inter-Con has revised our price proposal to align with the City’s current program requirements and preferred Year 1 budget structure. The revised proposal removes the 40 weekly hours of Day Shift parking enforcement previously included in the staffing model, consistent with the City’s clarification that these hours will not be staffed.

In addition, Inter-Con has reduced our Year 1 price, before contingency, to \$277,842 to align with the City’s expected FY 2026-27 budget. This reduction defers a portion of Year 1 cost recovery into Years 2 and 3, which results in larger out-year increases to return the program to neutral ground. However, the revised structure still maintains the overall three-year program cost at approximately \$937,000.

### **PRICING VALIDITY**

Pursuant to the terms of the RFP issued by the City, this proposal shall remain valid for 90 calendar days from the submission date of 06/05/26, unless otherwise agreed in writing.

### **PAYMENT TERMS**

Inter-Con’s pricing is based on payment terms of Net 30 days from receipt of invoice by the City. Any deviation from these terms may require a corresponding adjustment to the proposed rates.

### **MODIFICATIONS**

Inter-Con’s proposal includes fixed bill rates by position that are firm for the first three years of the program. Thereafter, if the City extends the contract for additional years, Inter-Con will modify our rates to account for increases in inflation based on the local metropolitan area Consumer Price Index for Urban Consumers (CPI-U).

During the life of the contract, should any unforeseeable costs arise at any time such as, but not limited to, changes to Federal, state, or local taxes; Federal, state, or local minimum wage rates that exert severe compression against our wage rates; or Federal, state, or local changes to regulations that affect overtime, paid time off, medical benefits, sick leave, etc., then Inter-Con will modify our rates so that such unexpected and unknowable costs can be covered.

### **REST AND MEAL BREAKS**

All personnel will receive paid rest breaks and unpaid meal periods in accordance with applicable law.

Inter-Con’s pricing assumes that personnel will either be self-relieving or relieved by existing Inter-Con personnel who are already scheduled in billable positions. If an additional dedicated breaker force beyond the existing billable posts is required, Inter-Con can provide this coverage as a separately billed service at our standard bill rate.

### **BILLABLE RATES**

Inter-Con’s proposed three-year bill rates are provided in the table below. We have maintained the same Day / Grave rate structure currently in place, preserving deployment flexibility for the City while clearly distinguishing between standard and overnight coverage requirements.

The pricing submitted in the City’s price form assumes the supervisor position – identified as Senior Parking Enforcement – is staffed on the Day shift. We understand this aligns with the City’s preferred operating structure. Should the City elect to assign this position to the Grave shift, the proposed Grave shift rate for Senior Parking Enforcement would apply.

Inter-Con differentiates between Day and Grave rates because overnight assignments present materially greater staffing and retention challenges for roles of this nature. Grave shift coverage typically requires premium compensation to support reliable staffing, reduce turnover risk, and maintain consistent service delivery during less desirable work hours.

<b>Position</b>	<b>Year 1 Bill Rate</b>	<b>Year 2 Bill Rate</b>	<b>Year 3 Bill Rate</b>
<b>Senior Parking Enforcement (Day)</b>	\$39.18	\$42.90	\$46.98
<b>Senior Parking Enforcement (Grave)</b>	\$45.14	\$49.43	\$54.13
<b>Parking Enforcement (Grave)</b>	\$42.20	\$46.21	\$50.60
<b>Parking Enforcement Weekend Grave</b>	\$50.08	\$54.84	\$60.05

### **CONTINGENCIES**

The City’s Price Proposal form requested that contractors include a cost for “Contingencies.” Inter-Con does not intend to invoice the City for any general contingency amount. Instead, Inter-Con will invoice only for hours of service actually performed at the proposed hourly labor rates, plus any billable City-provided training.

The amount shown in the contingency line reflects the City-paid training requirement of 80 hours for each newly hired representative. For budgeting purposes, Inter-Con estimated two personnel receiving this training during the year based on potential turnover. The actual training cost may be higher or lower depending on actual hiring and turnover activity.

The only other additional costs that would be invoiced are costs associated with City-requested services, equipment, training, vehicles, taxes, or other requirements that are outside the initial scope and not otherwise included in this proposal. These items are not forecastable to a reliable extent at this time because they depend on the specific nature, timing, and extent of any future

City-directed request. Any such costs would be priced, reviewed, and approved by the City before being incurred.

**WAGES**

Inter-Con’s pricing is based on known market-supported wages and benefit assumptions. Because Inter-Con is a longstanding partner with the City we have adjusted compensation to align with current market increases, however rates may be adjusted if such obligations exceed the assumptions reflected in the proposal.

Inter-Con reserves the right to adjust wages during contract performance in accordance with legal, contractual, and operational requirements; any impact to bill rates would be subject to mutual agreement.

**TRAINING**

Inter-Con has included the training hours listed in the table below.

	Unbillable	Billable	Unbillable	
Position	New Hire Training Hours	City-provided Training Hours	Annual Refresher Hours	Total Hours
All Positions	8	80	8	96

Inter-Con will provide new hire personnel with a minimum of eight (8) hours of Basic Training and eight (8) hours of annual Refresher, at no cost to the City. We understand per the RFP that an additional 80 hours of training will be provided by the City and will be billed at our regular bill rate. **Inter-Con proposes that any additional training be billed at our regular bill rate.**

**HOLIDAYS**

Inter-Con has included the cost of providing personnel with paid holidays. This cost has been included in our bill rate, **meaning the City will be billed at our regular rate for services provided on holidays.** Inter-Con’s recognized holidays for this program are shown below:

Recognized Holidays	
New Year’s Day	Labor Day
Memorial Day	Thanksgiving Day
Independence Day	Christmas Day

**COLLECTIVE BARGAINING AGREEMENTS (CBA)**

All sites within this RFP are non-union and have been priced accordingly. In the event any sites are determined to be subject to a Collective Bargaining Agreement (CBA), Inter-Con reserves the right to revise its pricing and bill rates to reflect the applicable labor requirements.

**VACATION / PAID TIME OFF / SICK LEAVE**

For all locations, Inter-Con’s pricing includes 40 hours of sick leave annually within the proposed bill rates. Any required additional hours beyond this included amount shall be billed separately as incurred.

**OVERTIME**

For all locations, scheduled and approved overtime will be billed as incurred at 1.5x the straight time rate. Under no circumstances would the City be billed at an overtime rate for unapproved

or unscheduled overtime because of Inter-Con’s staffing plan. Inter-Con absorbs all such overtime that is a result of our own staffing model.

## **TAXES AND COST OF RISK**

Inter-Con’s proposed rates include all applicable payroll taxes, as well as Workers’ Compensation and General Liability insurance costs.

## **MEDICAL BENEFITS**

Inter-Con has included estimated medical insurance premiums within our bill rates, with non-management personnel offered an ACA-compliant Bronze plan and salaried personnel eligible for our corporate medical program.

While embedded in pricing, Inter-Con recommends structuring medical premiums as a separate passthrough, as enrollment levels are unpredictable, and embedding costs may result in overestimation. Under a passthrough model, rates would be reduced accordingly, and the City would pay only for enrolled employees, improving cost accuracy and transparency.

## **UNIFORMS**

Uniform costs have been included within the bill rates. Any additional or recurring uniform requests will be billed separately as incurred.

## **BACKGROUND SCREENING & DRUG TESTING**

Background screening and drug testing costs have been included within the bill rates. Any additional or recurring screening will be billed separately as incurred.

## **EQUIPMENT**

All equipment identified within the RFP has been incorporated into the bill rates. Any additional or specialized equipment may be billed separately as incurred.

## **COMMUNICATIONS & TIMEKEEPING**

Inter-Con is pleased to utilize a proprietary mobile solution that was developed in partnership with Salesforce and enables unprecedented transparency and accountability for our security programs. This solution includes biometric time and attendance recordkeeping, incident reporting, and Virtual Post Inspections. This functionality will be delivered via the IC Mobile App installed on the officers’ own smartphone at no additional cost to the City.

Alternatively, if more advanced capabilities are required such as a Guard Tour, GPS Tracking, & NFC Tag System or if the City desires that employees not use their own phones, Inter-Con can provide our own smartphone devices at a per unit charge of \$125/month.

## **VEHICLES**

Inter-Con has included the cost of two (2) vehicles within our proposed bill rates. **The City will not be charged separately for vehicle costs under this program unless the City requests additional vehicles or vehicle-related equipment outside the current scope.**

Our included vehicle cost assumes a sedan-style vehicle, such as a Toyota Corolla Hybrid, and covers depreciation, fuel, insurance, maintenance, and general equipment. License Plate Reader equipment is not included in our vehicle pricing, as we understand this is not a requirement of the present scope of work. If LPRs or other additional vehicle equipment are required in the future, those costs would be priced, reviewed, and presented to the City for approval before being incurred.

---

## **ACCOUNT MANAGEMENT & SUPPORT**

Inter-Con has reviewed the account management support outlined by the City within the RFP and has incorporated the requested level of support within our pricing response. Any additional management support not specified within the RFP scope will be considered out-of-scope and billed separately as incurred.

## EXHIBIT C

### Activity Schedule

Consultant shall provide official parking enforcement services beginning July 1, 2026, through June 30, 2029, with the option of three, one-year renewals.

**DATE:** June 16, 2026

**TO:** Honorable Mayor and City Council

**FROM:** Dominic Lazzaretto, City Manager  
By: Linda Rodriguez, City Clerk

**SUBJECT:** PROFESSIONAL SERVICES AGREEMENT WITH VRC COMPANIES, LLC FOR LASERFICHE CLOUD AND SUPPORT SERVICES FROM JULY 1, 2026, THROUGH JUNE 30, 2029, IN THE AMOUNT OF \$76,842.20, WITH THE OPTION OF TWO ONE-YEAR EXTENSIONS  
**CEQA: Not a Project**  
**Recommendation: Approve**

### **SUMMARY**

The City has utilized Laserfiche document management software since 2006 to electronically store, retrieve, and manage official City records. In 2021, the City Council approved a Professional Services Agreement for Laserfiche document management software and support services. Laserfiche software and support services are exclusively provided by third-party resellers, and the City's current agreement is set to expire on June 30, 2026.

Arcadia currently hosts Laserfiche on-premise, which requires City servers to store and maintain nearly 800 gigabytes of documents and images locally. To create server capacity and to utilize the latest version of the software, the City needs to migrate to Laserfiche Cloud. This transition will modernize the City's document management system, improve accessibility and navigability for the public, and enhance long-term operational efficiency Citywide.

Following a competitive Request for Proposals ("RFP") process, it is recommended that the City Council approve a Professional Services Agreement with VRC Companies, LLC ("VRC") for Laserfiche Cloud and Support Services from July 1, 2026, through June 30, 2029, in the amount of \$76,842.20, with the option of two one-year

extensions. It is further recommended that the City Council delegate the authority to approve future extensions under this agreement to the City Manager, without having to return to the City Council for approval, provided that the annual costs remain within standard inflationary limits.

## **BACKGROUND**

The City Clerk's Office has used Laserfiche Document Management software since 2006 to store, share, and retrieve electronic files. Using Laserfiche scanning and indexing technology has allowed the City to be consistent in its image indexing procedures, maintain interdepartmental electronic access and file-sharing capabilities, and ensure adequate storage and access to public documents in accordance with the City's document retention schedules and the California Public Records Act.

The City currently operates an on-premises Laserfiche Avante Version 11 environment. As part of the City's ongoing efforts to modernize its technology infrastructure, improve system accessibility, and reduce reliance on locally hosted infrastructure, the City will transition from its existing on-premises platform to the Laserfiche Cloud environment. The transition to a cloud-based solution will free up vital storage space on two City servers and will require less ongoing support and maintenance from the City's IT Division.

Laserfiche requires that its customers obtain user licenses for both internal and external use of the system and utilizes third-party vendors as authorized resellers of licenses, software maintenance, implementation, and support services. Currently, the City maintains 15 licenses for City staff and 25 "view-only" licenses that provide public access to City documents through the Laserfiche portal on the City's website. The public portal was upgraded in 2025 from 10 unlimited "view only" licenses to 25. Even with this upgrade, there have been several points throughout the year where all 25 licenses are in use, and further access to Laserfiche is not available to the public or employees.

On June 15, 2021, the City Council approved a Professional Services Agreement with File Keepers, LLC for Laserfiche document management software maintenance and support services. File Keepers, LLC was subsequently acquired by VRC Companies,

LLC on January 1, 2023, and VRC assumed responsibility for providing those services to the City.

The City's current agreement with VRC Companies, LLC for Laserfiche licensing, maintenance, and support services is set to expire on June 30, 2026. To facilitate the City's migration to Laserfiche Cloud and ensure continued software licensing, implementation services, technical support, and system maintenance, the City conducted a competitive solicitation process for Laserfiche Cloud and Support Services.

## **DISCUSSION**

On April 15, 2026, a Notice Inviting Proposals was published in accordance with City Council Resolution No. 7483. In addition, requests for proposals were distributed to prospective vendors that provide these types of services.

An evaluation committee consisting of representatives from various City departments was established to review and evaluate the proposals. On May 8, 2026, the City received five (5) responsive proposals from Dynamic Document Services, ICC – Community Development, Ricoh, Global Solutions Group, Inc., and the incumbent, VRC Companies, LLC.

The maximum score a proposer could receive was 100 points. Proposals were evaluated based on the proposer's understanding of the scope of work, qualifications and experience, references, quality of the proposal, and overall cost. Following the evaluation of the proposals, the two highest-ranked firms were invited to participate in interviews and provide additional clarification regarding their proposals, implementation approach, support services, and experience with Laserfiche Cloud migrations.

The results of the evaluation process are summarized below:

<b>Rank</b>	<b>Vendor</b>	<b>Three-Year Cost Proposal</b>	<b>Total Score</b>
1	VRC Companies, LLC	\$76,842.20	88
2	Global Solutions Group, Inc.	\$78,137.45	85
3	Dynamic Document Services	\$74,300.00	80
4	ICC – Community Development	\$127,784.00	78
5	Ricoh	\$131,710.84	74

VRC submitted a highly competitive cost proposal and received the highest overall evaluation score among all proposers. In addition, as the City’s existing provider of these services, VRC has more in-depth knowledge of Arcadia’s current Laserfiche system and records repository, which should help with the transition to the cloud environment.

Based on the proposals, interviews, references, experience with Laserfiche Cloud implementations, and overall cost competitiveness, staff determined that VRC Companies, LLC is the firm best qualified to provide the requested services.

Accordingly, it is recommended that the City Council approve a Professional Services Agreement with VRC Companies, LLC for Laserfiche Cloud and Support Services from July 1, 2026, through June 30, 2029, in the amount of \$76,842.20, with the option of two one-year extensions.

**ENVIRONMENTAL ANALYSIS**

The proposed action does not constitute a project under the California Environmental Quality Act (“CEQA”), as it can be seen with certainty that it will have no impact on the environment.

**FISCAL IMPACT**

To secure the most competitive pricing for Laserfiche software and support services, a multi-year agreement was offered in the proposal. The Professional Services Agreement between VRC Companies, LLC and the City is based on a three-year term

in the amount of \$76,842.20, from July 1, 2026, through June 30, 2029, as shown below:

Fiscal Year 2026-27: \$24,375.00

Fiscal Year 2027-28: \$25,593.75

Fiscal Year 2028-29: \$26,873.45

The Proposed Operating Budget for Fiscal Year 2026-27 includes \$40,000 for Laserfiche Cloud software and support services. The proposed budget was developed several months before the results of the RFP process were known and the budget will be right sized for the contract expenses in future fiscal years. Subject to City Council approval, there will be sufficient funding in the FY 2026-27 Operating Budget for this purchase, as well as future budget years.

### **RECOMMENDATION**

It is recommended the City Council determine that this action does not constitute a project under the California Environmental Quality Act ("CEQA"); and authorize and direct the City Manager to execute a Professional Services Agreement with VRC Companies, LLC for Laserfiche Cloud and Support Services from July 1, 2026, through June 30, 2029, in the amount of \$76,842.20, with the option of two one-year extensions. It is further recommended that the City Council delegate the authority to approve future extensions under this agreement to the City Manager, without having to return to the City Council for approval, provided that any changes to the financial terms remain within standard inflationary limits.

Attachment: Proposed Professional Services Agreement

**CITY OF ARCADIA**  
**PROFESSIONAL SERVICES AGREEMENT REGARDING**  
**[\*\*\*INSERT PROJECT TITLE\*\*\*]**

This Agreement is made and entered into as of \_\_\_\_\_, 20\_\_\_\_ by and between the City of Arcadia, a municipal corporation organized and operating under the laws of the State of California with its principal place of business at 240 West Huntington Drive, Arcadia, California 91066 ("City"), and [\*\*\*INSERT NAME\*\*\*], a [\*\*\*INSERT TYPE OF ENTITY - CORPORATION, PARTNERSHIP, SOLE PROPRIETORSHIP OR OTHER LEGAL ENTITY\*\*\*] with its principal place of business at [\*\*\*INSERT ADDRESS\*\*\*] (hereinafter referred to as "Consultant"). City and Consultant are sometimes individually referred to as "Party" and collectively as "Parties" in this Agreement.

**RECITALS**

A. City is a public agency of the State of California and is in need of professional services for the following project:

\_\_\_\_\_ (hereinafter referred to as "the Project").

B. Consultant is duly licensed and has the necessary qualifications to provide such services.

C. The Parties desire by this Agreement to establish the terms for City to retain Consultant to provide the services described herein.

**AGREEMENT**

**NOW, THEREFORE, IT IS AGREED AS FOLLOWS:**

1. Services.

Consultant shall provide the City with the services described in the Scope of Services attached hereto as Exhibit "A." **[Alternatively, Scope of Services can be included here and all subsequent exhibits renumbered accordingly.]**

2. Compensation.

a. Subject to paragraph 2(b) below, the City shall pay for such services in accordance with the Schedule of Charges set forth in Exhibit "B." **[Alternatively, Schedule of Charges may be included here and all subsequent exhibits renumbered accordingly.]**

b. In no event shall the total amount paid for services rendered by Consultant under this Agreement exceed the sum of \$\_\_\_\_\_ **[Insert amount of compensation]**. This amount is to cover all printing and related costs, and the City will not pay any additional fees for printing expenses. Periodic payments shall be made within 30 days of receipt of an invoice which includes a detailed description of the work performed. Payments to Consultant for work performed will be made on a monthly billing basis.

3. Additional Work.

If changes in the work seem merited by Consultant or the City, and informal consultations with the other party indicate that a change is warranted, it shall be processed in the following manner: a letter outlining the changes shall be forwarded to the City by Consultant with a statement of estimated changes in fee or time schedule. An amendment to this Agreement shall be prepared by the City and executed by both Parties before performance of such services, or the City will not be required to pay for the changes in the scope of work. Such amendment shall not render ineffective or invalidate unaffected portions of this Agreement.

4. Maintenance of Records.

Books, documents, papers, accounting records, and other evidence pertaining to costs incurred shall be maintained by Consultant and made available at all reasonable times during the contract period and for four (4) years from the date of final payment under the contract for inspection by City.

5. **[Insert Term or Time of Performance]**.

**[If engaging the Consultant for a particular term, use the following provision]**

The term of this Agreement shall be from **[Insert start date]** to **[Insert end date]**, unless earlier terminated as provided herein. The Parties may, by mutual, written consent, extend the term of this Agreement if necessary to complete the Project. Consultant shall perform its services in a prompt and timely manner within the term of this Agreement and shall commence performance upon receipt of written notice from the City to proceed ("Notice to Proceed"). **[If the City has specific milestones or timelines for performance, please input those requirements in the "Activity Schedule" attached as Exhibit C, otherwise delete Exhibit C.]** The Notice to Proceed shall set forth the date of commencement of work.

**[If engaging the Consultant to perform a discrete task with a specified deadline, use the following provision]**

Consultant shall perform its services in a prompt and timely manner and shall commence performance upon receipt of written notice from the City to proceed ("Notice to Proceed"). Consultant shall complete the services required hereunder within **[Insert**

**number of calendar days for performance of the services - if more detail is required attach "Activity Schedule" as Exhibit C, otherwise delete Exhibit C.]** The Notice to Proceed shall set forth the date of commencement of work.

6. Delays in Performance.

a. Neither City nor Consultant shall be considered in default of this Agreement for delays in performance caused by circumstances beyond the reasonable control of the non-performing party. For purposes of this Agreement, such circumstances include but are not limited to, abnormal weather conditions; floods; earthquakes; fire; epidemics; war; riots and other civil disturbances; strikes, lockouts, work slowdowns, and other labor disturbances; sabotage or judicial restraint.

b. Should such circumstances occur, the non-performing party shall, within a reasonable time of being prevented from performing, give written notice to the other party describing the circumstances preventing continued performance and the efforts being made to resume performance of this Agreement.

7. Compliance with Law.

a. Consultant shall comply with all applicable laws, ordinances, codes and regulations of the federal, state and local government, including Cal/OSHA requirements.

b. If required, Consultant shall assist the City, as requested, in obtaining and maintaining all permits required of Consultant by federal, state and local regulatory agencies.

c. If applicable, Consultant is responsible for all costs of clean up and/ or removal of hazardous and toxic substances spilled as a result of his or her services or operations performed under this Agreement.

8. Standard of Care

Consultant's services will be performed in accordance with generally accepted professional practices and principles and in a manner consistent with the level of care and skill ordinarily exercised by members of the profession currently practicing under similar conditions.

9. Assignment and Subconsultant

Consultant shall not assign, sublet, or transfer this Agreement or any rights under or interest in this Agreement without the written consent of the City, which may be withheld for any reason. Any attempt to so assign or so transfer without such consent shall be void and without legal effect and shall constitute grounds for termination. Subcontracts, if any, shall

contain a provision making them subject to all provisions stipulated in this Agreement. Nothing contained herein shall prevent Consultant from employing independent associates, and subconsultants as Consultant may deem appropriate to assist in the performance of services hereunder.

10. Independent Contractor

Consultant is retained as an independent contractor and is not an employee of City. No employee or agent of Consultant shall become an employee of City. The work to be performed shall be in accordance with the work described in this Agreement, subject to such directions and amendments from City as herein provided.

11. Insurance. Consultant shall not commence work for the City until it has provided evidence satisfactory to the City it has secured all insurance required under this section. In addition, Consultant shall not allow any subcontractor to commence work on any subcontract until it has secured all insurance required under this section.

a. Commercial General Liability

(i) The Consultant shall take out and maintain, during the performance of all work under this Agreement, in amounts not less than specified herein, Commercial General Liability Insurance, in a form and with insurance companies acceptable to the City.

(ii) Coverage for Commercial General Liability insurance shall be at least as broad as the following:

(1) Insurance Services Office Commercial General Liability coverage (Occurrence Form CG 00 01) or exact equivalent.

(iii) Commercial General Liability Insurance must include coverage for the following:

- (1) Bodily Injury and Property Damage
- (2) Personal Injury/Advertising Injury
- (3) Premises/Operations Liability
- (4) Products/Completed Operations Liability **Consultant shall procure and submit evidence of insurance for at least five (5) years from the time that all work under this Agreement is completed.**
- (5) Aggregate Limits that Apply per Project
- (6) Explosion, Collapse and Underground (UCX) exclusion deleted
- (7) Contractual Liability with respect to this Agreement
- (8) Property Damage

(9) Independent Consultants Coverage

(iv) The policy shall contain no endorsements or provisions limiting coverage for (1) contractual liability; (2) cross liability exclusion for claims or suits by one insured against another; (3) products/completed operations liability; or (4) contain any other exclusion contrary to the Agreement.

(v) The policy shall give City, its officials, officers, employees, agents and City designated volunteers additional insured status using ISO endorsement forms CG 20 10 10 01 and 20 37 10 01, or endorsements providing the exact same coverage. Consultant may provide blanket endorsements to meet the Additional Insured requirement in this written contract. However, all subcontractors' endorsements shall specifically name the City, its elected officials, officers, employees, volunteers, boards, agents, and representatives as additional insureds and blanket endorsements are not acceptable.

(vi) The general liability program may utilize either deductibles or provide coverage excess of a self-insured retention, subject to written approval by the City, and provided that such deductibles shall not apply to the City as an additional insured.

b. Automobile Liability

(i) At all times during the performance of the work under this Agreement, the Consultant shall maintain Automobile Liability Insurance for bodily injury and property damage including coverage for owned, non-owned and hired vehicles, in a form and with insurance companies acceptable to the City.

(ii) Coverage for automobile liability insurance shall be at least as broad as Insurance Services Office Form Number CA 00 01 covering automobile liability (Coverage Symbol 1, any auto).

(iii) The policy shall give City, its officials, officers, employees, agents and City designated volunteers additional insured status. Consultant may provide blanket endorsements to meet the Additional Insured requirement in this written contract. However, all subcontractors' endorsements shall specifically name the City, its elected officials, officers, employees, volunteers, boards, agents, and representatives as additional insureds and blanket endorsements are not acceptable.

(iv) Subject to written approval by the City, the automobile liability program may utilize deductibles, provided that such deductibles shall not apply to the City as an additional insured, but not a self-insured retention.

c. Workers' Compensation/Employer's Liability

(i) Consultant certifies that he/she is aware of the provisions of Section 3700 of the California Labor Code which requires every employer to be insured

against liability for workers' compensation or to undertake self-insurance in accordance with the provisions of that code, and he/she will comply with such provisions before commencing work under this Agreement.

(ii) To the extent Consultant has employees at any time during the term of this Agreement, at all times during the performance of the work under this Agreement, the Consultant shall maintain full compensation insurance for all persons employed directly by him/her to carry out the work contemplated under this Agreement, all in accordance with the "Workers' Compensation and Insurance Act," Division IV of the Labor Code of the State of California and any acts amendatory thereof, and Employer's Liability Coverage in amounts indicated herein. Consultant shall require all subconsultants to obtain and maintain, for the period required by this Agreement, workers' compensation coverage of the same type and limits as specified in this section.

d. Professional Liability (Errors and Omissions)

At all times during the performance of the work under this Agreement the Consultant shall maintain professional liability or Errors and Omissions insurance appropriate to its profession, in a form and with insurance companies acceptable to the City and in an amount indicated herein. This insurance shall be endorsed to include contractual liability applicable to this Agreement and shall be written on a policy form coverage specifically designed to protect against acts, errors or omissions of the Consultant. "Covered Professional Services" as designated in the policy must specifically include work performed under this Agreement. The policy must "pay on behalf of" the insured and must include a provision establishing the insurer's duty to defend.

**[Delete the following provision and renumber all further provisions, if not applicable.]**

e. Cyber Liability Insurance.

Cyber Liability Insurance covering (1) all acts, errors, omissions, negligence, infringement of intellectual property; (2) network security and privacy risks, including but not limited to unauthorized access, failure of security, breach of privacy perils, wrongful disclosure, collection, or negligence in the handling of confidential information, privacy perils, including coverage for related regulatory defense and penalties; (3) system failure, damage to or destruction of electronic information, data recovery, business interruption, cyber extortion, and information theft; (4) data breach expenses payable whether incurred by City or Consultant, including but not limited to consumer notification, whether or not required by law, computer forensic investigations, public relations and crisis management firm fees, credit file or identity monitoring or remediation services in the performance of services for City or on behalf of City hereunder. If a sub-limit applies to any elements of coverage, the certificate of insurance evidencing the coverage above must specify the coverage section and the amount of the sub-limit.

f. Minimum Policy Limits Required

(i) The following insurance limits are required for the Agreement:

Combined Single Limit

Commercial General Liability	\$1,000,000 per occurrence/ \$2,000,000 aggregate for bodily injury, personal injury, and property damage
Automobile Liability	\$1,000,000 per occurrence for bodily injury and property damage
Employer's Liability	\$1,000,000 per occurrence
Professional Liability	\$1,000,000 per claim and aggregate (errors and omissions)
<b>[Remove Cyber if not applicable. Common insurance for website hosting]</b>	
Cyber Liability	\$5,000,000 per claim and annual aggregate

(ii) Defense costs shall be payable in addition to the limits.

(iii) Requirements of specific coverage or limits contained in this section are not intended as a limitation on coverage, limits, or other requirement, or a waiver of any coverage normally provided by any insurance. Any available coverage shall be provided to the parties required to be named as Additional Insured pursuant to this Agreement.

g. Evidence Required

Prior to execution of the Agreement, the Consultant shall file with the City evidence of insurance from an insurer or insurers certifying to the coverage of all insurance required herein. Such evidence shall include original copies of the ISO CG 00 01 (or insurer's equivalent) signed by the insurer's representative and Certificate of Insurance (Acord Form 25-S or equivalent), together with required endorsements. All evidence of insurance shall be signed by a properly authorized officer, agent, or qualified representative of the insurer and shall certify the names of the insured, any additional insureds, where appropriate, the type and amount of the insurance, the location and operations to which the insurance applies, and the expiration date of such insurance.

h. Policy Provisions Required

(i) Consultant shall provide the City at least thirty (30) days prior written notice of cancellation of any policy required by this Agreement, except that the Consultant shall provide at least ten (10) days prior written notice of cancellation of any such

policy due to non-payment of premium. If any of the required coverage is cancelled or expires during the term of this Agreement, the Consultant shall deliver renewal certificate(s) including the General Liability Additional Insured Endorsement to the City at least ten (10) days prior to the effective date of cancellation or expiration. Consultant may provide blanket endorsements to meet the Additional Insured requirement in this written contract. However, all subcontractors' endorsements shall specifically name the City, its elected officials, officers, employees, volunteers, boards, agents, and representatives as additional insureds and blanket endorsements are not acceptable.

(ii) The Commercial General Liability Policy and Automobile Policy shall each contain a provision stating that Consultant's policy is primary insurance and that any insurance, self-insurance or other coverage maintained by the City or any named insureds shall not be called upon to contribute to any loss.

(iii) The retroactive date (if any) of each policy is to be no later than the effective date of this Agreement. Consultant shall maintain such coverage continuously for a period of at least three years after the completion of the work under this Agreement. Consultant shall purchase a one (1) year extended reporting period A) if the retroactive date is advanced past the effective date of this Agreement; B) if the policy is cancelled or not renewed; or C) if the policy is replaced by another claims-made policy with a retroactive date subsequent to the effective date of this Agreement.

(iv) All required insurance coverages, except for the professional liability coverage, shall contain or be endorsed to waiver of subrogation in favor of the City, its officials, officers, employees, agents, and volunteers or shall specifically allow Consultant or others providing insurance evidence in compliance with these specifications to waive their right of recovery prior to a loss. Consultant hereby waives its own right of recovery against City, and shall require similar written express waivers and insurance clauses from each of its subconsultants.

(v) The limits set forth herein shall apply separately to each insured against whom claims are made or suits are brought, except with respect to the limits of liability. Further the limits set forth herein shall not be construed to relieve the Consultant from liability in excess of such coverage, nor shall it limit the Consultant's indemnification obligations to the City and shall not preclude the City from taking such other actions available to the City under other provisions of the Agreement or law.

i. Qualifying Insurers

(i) All policies required shall be issued by acceptable insurance companies, as determined by the City, which satisfy the following minimum requirements:

(1) Each such policy shall be from a company or companies with a current A.M. Best's rating of no less than A:VII and admitted to transact in the

business of insurance in the State of California, or otherwise allowed to place insurance through surplus line brokers under applicable provisions of the California Insurance Code or any federal law.

j. Additional Insurance Provisions

(i) The foregoing requirements as to the types and limits of insurance coverage to be maintained by Consultant, and any approval of said insurance by the City, is not intended to and shall not in any manner limit or qualify the liabilities and obligations otherwise assumed by the Consultant pursuant to this Agreement, including but not limited to, the provisions concerning indemnification.

(ii) If at any time during the life of the Agreement, any policy of insurance required under this Agreement does not comply with these specifications or is canceled and not replaced, City has the right but not the duty to obtain the insurance it deems necessary and any premium paid by City will be promptly reimbursed by Consultant or City will withhold amounts sufficient to pay premium from Consultant payments. In the alternative, City may cancel this Agreement.

(iii) The City may require the Consultant to provide complete copies of all insurance policies in effect for the duration of the Project.

(iv) Neither the City nor any of its officials, officers, employees, agents or volunteers shall be personally responsible for any liability arising under or by virtue of this Agreement.

k. Subconsultant Insurance Requirements. Consultant shall not allow any subcontractors or subconsultants to commence work on any subcontract until they have provided evidence satisfactory to the City that they have secured all insurance required under this section. Policies of commercial general liability insurance provided by such subcontractors or subconsultants shall be endorsed to name the City as an additional insured using ISO form CG 20 38 04 13 or an endorsement providing the exact same coverage. All subcontractors' endorsements shall specifically name the City, its elected officials, officers, employees, volunteers, boards, agents, and representatives as additional insureds and blanket endorsements are not acceptable. If requested by Consultant, City may approve different scopes or minimum limits of insurance for particular subcontractors or subconsultants.

12. Indemnification.

a. To the fullest extent permitted by law, Consultant shall defend (with counsel of City's choosing), indemnify and hold the City, its officials, officers, employees, volunteers, and agents free and harmless from any and all claims, demands, causes of action, costs, expenses, liability, loss, damage or injury of any kind, in law or equity, to property or persons, including wrongful death, in any manner arising out of, pertaining to, or incident

to any acts, errors or omissions, or willful misconduct of Consultant, its officials, officers, employees, subcontractors, consultants or agents in connection with the performance of the Consultant's services, the Project or this Agreement, including without limitation the payment of all damages, expert witness fees and attorney's fees and other related costs and expenses. Consultant's obligation to indemnify shall not be restricted to insurance proceeds, if any, received by Consultant, the City, its officials, officers, employees, agents, or volunteers.

b. To the extent required by Civil Code section 2782.8, which is fully incorporated herein, Consultant's obligations under the above indemnity shall be limited to claims that arise out of, pertain to, or relate to the negligence, recklessness, or willful misconduct of the Consultant, but shall not otherwise be reduced. If Consultant's obligations to defend, indemnify, and/or hold harmless arise out of Consultant's performance of "design professional services" (as that term is defined under Civil Code section 2782.8), then upon Consultant obtaining a final adjudication that liability under a claim is caused by the comparative active negligence or willful misconduct of the City, Consultant's obligations shall be reduced in proportion to the established comparative liability of the City and shall not exceed the Consultant's proportionate percentage of fault.

### 13. California Labor Code Requirements.

a. Consultant is aware of the requirements of California Labor Code Sections 1720 et seq. and 1770 et seq., which require the payment of prevailing wage rates and the performance of other requirements on certain "public works" and "maintenance" projects ("Prevailing Wage Laws"). If the services are being performed as part of an applicable "public works" or "maintenance" project, as defined by the Prevailing Wage Laws, and if the total compensation is \$15,000 or more for maintenance or \$25,000 or more for construction, alteration, demolition, installation, or repair, Consultant agrees to fully comply with such Prevailing Wage Laws. Consultant shall defend, indemnify and hold the City, its officials, officers, employees and agents free and harmless from any claims, liabilities, costs, penalties or interest arising out of any failure or alleged failure to comply with the Prevailing Wage Laws. It shall be mandatory upon the Consultant and all subconsultants to comply with all California Labor Code provisions, which include but are not limited to prevailing wages (Labor Code Sections 1771, 1774 and 1775), employment of apprentices (Labor Code Section 1777.5), certified payroll records (Labor Code Sections 1771.4 and 1776), hours of labor (Labor Code Sections 1813 and 1815) and debarment of contractors and subcontractors (Labor Code Section 1777.1).

b. If the services are being performed as part of an applicable "public works" or "maintenance" project and if the total compensation is \$15,000 or more for maintenance or \$25,000 or more for construction, alteration, demolition, installation, or repair, then pursuant to Labor Code Sections 1725.5 and 1771.1, the Consultant and all subconsultants performing such services must be registered with the Department of Industrial Relations. Consultant shall maintain registration for the duration of the Project

and require the same of any subconsultants, as applicable. This Project may also be subject to compliance monitoring and enforcement by the Department of Industrial Relations. It shall be Consultant's sole responsibility to comply with all applicable registration and labor compliance requirements.

c. This Agreement may also be subject to compliance monitoring and enforcement by the Department of Industrial Relations. It shall be Consultant's sole responsibility to comply with all applicable registration and labor compliance requirements. Any stop orders issued by the Department of Industrial Relations against Consultant or any subcontractor that affect Consultant's performance of services, including any delay, shall be Consultant's sole responsibility. Any delay arising out of or resulting from such stop orders shall be considered Consultant caused delay and shall not be compensable by the City. Consultant shall defend, indemnify and hold the City, its officials, officers, employees and agents free and harmless from any claim or liability arising out of stop orders issued by the Department of Industrial Relations against Consultant or any subcontractor.

14. Verification of Employment Eligibility.

By executing this Agreement, Consultant verifies that it fully complies with all requirements and restrictions of state and federal law respecting the employment of undocumented aliens, including, but not limited to, the Immigration Reform and Control Act of 1986, as may be amended from time to time, and shall require all subconsultants and sub-subconsultants to comply with the same.

**[Delete the following provision and renumber all further provisions, if not applicable.]**

15. City Material Requirements.

Consultant is hereby made aware of the City's requirements regarding materials, as set forth in **[Insert the name of the document that contains the City's standard material requirements]**, which are deemed to be a part of this Agreement.

16. Laws and Venue.

This Agreement shall be interpreted in accordance with the laws of the State of California. If any action is brought to interpret or enforce any term of this Agreement, the action shall be brought in a state or federal court situated in the County of Los Angeles, State of California.

17. Termination or Abandonment

a. City has the right to terminate or abandon any portion or all of the work under this Agreement by giving ten (10) calendar days written notice to Consultant. In such event, City shall be immediately given title and possession to all original field notes, drawings and specifications, written reports and other documents produced or developed for that portion of the work completed and/or being abandoned. City shall pay Consultant the

reasonable value of services rendered for any portion of the work completed prior to termination. If said termination occurs prior to completion of any task for the Project for which a payment request has not been received, the charge for services performed during such task shall be the reasonable value of such services, based on an amount mutually agreed to by City and Consultant of the portion of such task completed but not paid prior to said termination. City shall not be liable for any costs other than the charges or portions thereof which are specified herein. Consultant shall not be entitled to payment for unperformed services, and shall not be entitled to damages or compensation for termination of work.

b. Consultant may terminate its obligation to provide further services under this Agreement upon thirty (30) calendar days' written notice to City only in the event of substantial failure by City to perform in accordance with the terms of this Agreement through no fault of Consultant.

18 Documents. Except as otherwise provided in "Termination or Abandonment," above, all original field notes, written reports, Drawings and Specifications and other documents, produced or developed for the Project shall, upon payment in full for the services described in this Agreement, be furnished to and become the property of the City.

19. Organization

Consultant shall assign [REDACTED] as Project Manager. The Project Manager shall not be removed from the Project or reassigned without the prior written consent of the City.

20. Limitation of Agreement.

This Agreement is limited to and includes only the work included in the Project described above.

21. Notice

Any notice or instrument required to be given or delivered by this Agreement may be given or delivered by depositing the same in any United States Post Office, certified mail, return receipt requested, postage prepaid, addressed to:

CITY:

City of Arcadia  
240 West Huntington Drive  
Arcadia, CA 91066

CONSULTANT:

[\*\*\*INSERT NAME, ADDRESS & CONTACT PERSON\*\*\*]

Attn: [\*\*\*INSERT NAME & DEPARTMENT\*\*\*]

and shall be effective upon receipt thereof.

22. Third Party Rights

Nothing in this Agreement shall be construed to give any rights or benefits to anyone other than the City and the Consultant.

23. Equal Opportunity Employment.

Consultant represents that it is an equal opportunity employer and that it shall not discriminate against any employee or applicant for employment because of race, religion, color, national origin, ancestry, sex, age or other interests protected by the State or Federal Constitutions. Such non-discrimination shall include, but not be limited to, all activities related to initial employment, upgrading, demotion, transfer, recruitment or recruitment advertising, layoff or termination.

24. Entire Agreement

This Agreement, with its exhibits, represents the entire understanding of City and Consultant as to those matters contained herein, and supersedes and cancels any prior or contemporaneous oral or written understanding, promises or representations with respect to those matters covered hereunder. Each party acknowledges that no representations, inducements, promises or agreements have been made by any person which are not incorporated herein, and that any other agreements shall be void. This Agreement may not be modified or altered except in writing signed by both Parties hereto. This is an integrated Agreement.

25. Severability

The unenforceability, invalidity or illegality of any provision(s) of this Agreement shall not render the provisions unenforceable, invalid or illegal.

26. Successors and Assigns

This Agreement shall be binding upon and shall inure to the benefit of the successors in interest, executors, administrators and assigns of each party to this Agreement. However, Consultant shall not assign or transfer by operation of law or otherwise any or all of its rights, burdens, duties or obligations without the prior written consent of City. Any attempted assignment without such consent shall be invalid and void.

27. Non-Waiver

None of the provisions of this Agreement shall be considered waived by either party, unless such waiver is specifically specified in writing.

28. Time of Essence

Time is of the essence for each and every provision of this Agreement.

29. City's Right to Employ Other Consultants

City reserves its right to employ other consultants, including engineers, in connection with this Project or other projects.

30. Prohibited Interests

Consultant maintains and warrants that it has not employed nor retained any company or person, other than a bona fide employee working solely for Consultant, to solicit or secure this Agreement. Further, Consultant warrants that it has not paid nor has it agreed to pay any company or person, other than a bona fide employee working solely for Consultant, any fee, commission, percentage, brokerage fee, gift or other consideration contingent upon or resulting from the award or making of this Agreement. For breach or violation of this warranty, City shall have the right to rescind this Agreement without liability. For the term of this Agreement, no director, official, officer or employee of City, during the term of his or her service with City, shall have any direct interest in this Agreement, or obtain any present or anticipated material benefit arising therefrom.

31. Federal Requirements [\*\*\*INCLUDE THIS SECTION ONLY IF APPLICABLE; DELETE OTHERWISE AND DELETE ASSOCIATED EXHIBIT. YOU MAY ALSO NEED TO INCLUDE SOME INFORMATION IN THE RFP DUE TO FEDERAL FUNDING GUIDELINES. CONSULT LEGAL COUNSEL IF NECESSARY\*\*\*]

When funding for the services is provided, in whole or in part, by an agency of the federal government, Consultant shall also fully and adequately comply with the provisions included in Exhibit "D" (Federal Requirements) attached hereto and incorporated herein by reference ("Federal Requirements"). With respect to any conflict between such Federal Requirements and the terms of this Agreement and/or the provisions of state law, the more stringent requirement shall control.

**[SIGNATURES ON FOLLOWING PAGE]**

**SIGNATURE PAGE FOR PROFESSIONAL SERVICES AGREEMENT  
BETWEEN THE CITY OF ARCADIA  
AND [\*\*\*INSERT NAME\*\*\*]**

IN WITNESS WHEREOF, the Parties have executed this Agreement as of the date first written above.

CITY OF ARCADIA

[INSERT NAME OF CONSULTANT]

By: \_\_\_\_\_  
Dominic Lazzaretto  
City Manager

By: \_\_\_\_\_  
Signature

Date: \_\_\_\_\_

Its: \_\_\_\_\_

ATTEST:

\_\_\_\_\_  
Printed Name

By: \_\_\_\_\_  
City Clerk

Date: \_\_\_\_\_

APPROVED AS TO FORM

By: \_\_\_\_\_  
Signature

By: \_\_\_\_\_  
Stephen P. Deitsch  
City Attorney

Its: \_\_\_\_\_

\_\_\_\_\_  
Printed Name

EXHIBIT A

Scope of Services

DRAFT

## EXHIBIT B

### Schedule of Charges/Payments

Consultant will invoice City on a monthly cycle. Consultant will include with each invoice a detailed progress report that indicates the amount of budget spent on each task. Consultant will inform City regarding any out-of-scope work being performed by Consultant. This is a time-and-materials contract.

DRAFT

EXHIBIT C  
Activity Schedule

DRAFT

EXHIBIT D

Federal Requirements

DRAFT

**DATE:** June 16, 2026

**TO:** Honorable Mayor and City Council

**FROM:** Roy Nakamura, Chief of Police  
By: Amber Abeyta, Management Analyst

**SUBJECT:** PROFESSIONAL SERVICES AGREEMENT WITH THE PASADENA HUMANE SOCIETY FOR ANIMAL CONTROL SERVICES IN AN AMOUNT NOT TO EXCEED \$2,115,648 FOR A FIVE-YEAR PERIOD, BEGINNING JULY 1, 2026, THROUGH JUNE 30, 2031

**CEQA: Not a Project**

**Recommendation: Approve**

## **SUMMARY**

The Professional Services Agreement (“Agreement”) with the Pasadena Humane Society (“Pasadena Humane”) for animal control services expires on June 30, 2026. It is recommended that the City Council approve, authorize, and direct the City Manager to execute a Professional Services Agreement with Pasadena Humane for animal control services in an amount not to exceed \$2,115,648 for a five-year period, beginning July 1, 2026, through June 30, 2031.

## **BACKGROUND**

Since 1993, the City has contracted with Pasadena Humane for animal control services. The services consist of field services, shelter services, medical services, reporting, community programming, low-cost public spay/neuter services, vaccination clinics, public education, animal training classes, wildlife rehabilitation, and animal licenses. In addition, they provide all staffing, equipment, and supplies needed to provide services. The existing contract for animal control services, which began on July 21, 2021, will expire on June 30, 2026. Pasadena Humane is proposing a renewal of the Agreement (Attachment No. 1) for another five-year period, maintaining similar terms and conditions.

In 2019, the City conducted extensive research to explore alternative animal control options after Pasadena Humane proposed a significant cost increase without sufficient details. The options included a long term contract with Pasadena Humane, a change in service provider to Los Angeles County, the formation of a Joint Powers Authority with local cities seeking animal control services or providing in-house services. Ultimately, it was concluded that a long-term contract with Pasadena Humane was the most cost-effective option.

## **DISCUSSION**

Pasadena Humane has proposed an updated pricing structure that affords greater certainty to all contracting cities over the new five-year Agreement. The pricing structure provides a moderate increase in price to offset escalating costs and volumes, and gradually moves all their contract cities to a common formula based on population, animal intakes, and field services calls. The table below lists the proposed monthly pricing for all parties, including Arcadia.

<b>City</b>	<b>Year 1</b>	<b>Year 2</b>	<b>Year 3</b>	<b>Year 4</b>	<b>Year 5</b>
	<b>FY2026-27</b>	<b>FY2027-28</b>	<b>FY2028-29</b>	<b>FY2029-30</b>	<b>FY2030-31</b>
<b>Arcadia</b>	\$32,835	\$34,005	\$35,218	\$36,473	\$37,773
<b>Bradbury</b>	\$1,181	\$1,332	\$1,501	\$1,693	\$1,908
<b>La Canada Flintridge</b>	\$10,055	\$10,083	\$10,111	\$10,139	\$10,167
<b>Monrovia</b>	\$24,571	\$26,527	\$28,638	\$30,918	\$33,379
<b>Pasadena</b>	\$165,664	\$169,994	\$174,437	\$178,996	\$183,674
<b>San Marino</b>	\$8,599	\$8,903	\$9,217	\$9,542	\$9,879
<b>Sierra Madre</b>	\$5,174	\$5,590	\$6,038	\$6,524	\$7,048
<b>South Pasadena</b>	\$17,377	\$18,045	\$18,739	\$19,459	\$20,207

The new pricing methodology reflects the following:

- Year 1 - Initial 10% increase applied to current pricing to compensate for capped increases over the past 5 years and industry specific cost increases.
- Express the Year 5 price as a formula based on current levels of population, live animal intakes, and service call volume to achieve consistency over time.

- Apply equal percent increases in years 2 to 4 to gradually rise from the Year 1 price to the Year 5 price.

The City's annual cost for the animal control services for the new five-year period is listed below.

Year 1	Year 2	Year 3	Year 4	Year 5
<b>2026-27</b>	<b>2027-28</b>	<b>2028-29</b>	<b>2029-30</b>	<b>2030-31</b>
\$394,020	\$408,060	\$422,616	\$437,676	\$453,276

In addition to the annual fee, Pasadena Humane generates revenue annually from licensing and penalty fees paid by Arcadia residents, in accordance with the City's Municipal Code (AMC 4124.2.2). For 2025, \$59,301 was collected in licensing (\$53,331) and penalty fees (\$5,970) from Arcadia residents, and these funds were retained by Pasadena Humane. Under the Agreement, Pasadena Humane retains 100% of all revenues brought in by the City.

Overall, the new Agreement establishes a more equitable framework that aligns the financial responsibilities with the level of service each city requires, making it the most cost effective option for animal control services.

**ENVIRONMENTAL ANALYSIS**

The proposed action does not constitute a project under the California Environmental Quality Act ("CEQA"), based on Section 15061(b)(3) of the CEQA Guidelines, as it can be seen with certainty that it will have no impact on the environment.

**FISCAL IMPACT**

Sufficient funds in the amount of \$394,020 for the first year of the Agreement have been allocated in the Fiscal Year 2026-27 General Fund Operating Budget. If approved, future year costs will be budgeted accordingly in the City's General Fund Operating Budget.

**RECOMMENDATION**

It is recommended that the City Council determine that this action does not constitute a project under the California Environmental Quality Act ("CEQA"); and approve, authorize and direct the City Manager to execute a Professional Services Agreement with the Pasadena Humane Society for animal control services in an amount not to exceed \$2,115,648 for a five-year period, beginning July 1, 2026, through June 30, 2031.

Approved:



Dominic Lazzaretto  
City Manager

Attachment No. 1: Pasadena Humane Animal Control Services Agreement

# **PROFESSIONAL SERVICES AGREEMENT FOR ANIMAL SHELTER AND ANIMAL CONTROL SERVICES**

Pasadena Humane / City of Arcadia

THIS AGREEMENT ("Agreement") is made and entered into as of this 1st day of July, 2026 ("Effective Date"), by and between the CITY OF ARCADIA, a municipal corporation ("City"), and the PASADENA HUMANE SOCIETY, doing business as PASADENA HUMANE, a nonprofit corporation with headquarters at 361 South Raymond Avenue, Pasadena, CA 91105 ("Pasadena Humane").

## **WITNESSETH**

**WHEREAS**, Pasadena Humane is currently providing animal shelter and animal control services for City; and

**WHEREAS**, City desires to maintain the services provided by Pasadena Humane and use the services, supplies, equipment, and facilities of Pasadena Humane in the enforcement and performance of the powers and duties as set forth in the City Municipal Code; and

**WHEREAS**, Pasadena Humane is willing to provide such services, supplies, materials, and use of its equipment and facilities in the enforcement and performance of said powers and duties and to provide animal shelter and animal control services herein stated; and

**WHEREAS**, Pasadena Humane represents that it has that degree of specialized expertise contemplated within California Government Code, Section 37103, and holds all necessary licenses to practice and perform the services herein contemplated; and

**WHEREAS**, no official or employee of City has a financial interest, within the provisions of California Government Code, Sections 1090-1092, in the subject matter of this Agreement.

**NOW, THEREFORE**, in consideration of the mutual covenants and conditions contained herein, City and Pasadena Humane do hereby agree as follows:

## **1.0 SERVICES PROVIDED BY PASADENA HUMANE**

- 1.1 **SCOPE OF SERVICES.** Pasadena Humane shall perform the professional services identified in the Scope of Services attached hereto as Exhibit "A" and incorporated herein by this reference. City shall have the right to request, in writing, additional services beyond what is set forth in the Scope of Services. Any such changes mutually agreed upon by the parties, and any corresponding increase in compensation, shall be incorporated by written amendment to this Agreement.

- 1.2 **PROFESSIONAL PRACTICES.** Pursuant to this Agreement, Pasadena Humane shall provide personnel experienced in their respective fields and in a manner consistent with the standards of care, diligence, and skill ordinarily exercised by service providers in similar fields and circumstances in accordance with sound professional practices.
- 1.3 **WARRANTY.** Pasadena Humane warrants that it shall perform the services required by this Agreement in compliance with all applicable Federal and California employment laws including, but not limited to, those laws related to minimum hours and wages; occupational health and safety; fair employment and employment practices; workers' compensation insurance and safety in employment; animal control and all other Federal, State and local laws and ordinances applicable to the services required under this Agreement. Pasadena Humane warrants that it shall advise City of Arcadia of any changes in laws that may affect Pasadena Humane's performance of this agreement.
- 1.4 **NON-DISCRIMINATION.** In performing this Agreement, Pasadena Humane shall not engage in, nor permit its agents to engage in, discrimination in employment of persons because of their race, religious creed color, national origin, ancestry, age, physical disability, mental disability, disability, medical condition, genetic information, marital status, sex, gender, gender identity, gender expression, age, sexual orientation, or military and veteran status except as permitted pursuant to Section 12940 of the Government Code. Violation of this provision may result in the imposition of penalties referred to in Labor Code, Section 1735.
- 1.5 **DELEGATION AND ASSIGNMENT.** Pasadena Humane cannot assign or delegate or otherwise transfer this Agreement or the rights or duties contained herein to any individual, person or legal entity without the written consent of the City. Pasadena Humane may engage a subcontractor(s) as permitted by law and may employ other personnel to perform services contemplated by this Agreement at Pasadena Humane's expense.
- 1.6 **ANIMAL LICENSURE.** Pasadena Humane shall issue City animal licenses for rabies vaccinated pets in compliance with licensing ordinances and fees as established by each individual City. One hundred percent of the revenue of the licensing service will be retained by Pasadena Humane. Such rates shall be established in accordance with all applicable State and local laws and as adopted by each individual City.

Each party to this Agreement would like to move towards a standardized rate for all of the Cities that Pasadena Humane serves. This standard rate may be determined by a licensing fee analysis and cost comparison, with recommended licensing rates to be agreed upon by all parties and ratified by the individual

Cities. In the absence of this analysis and cost comparison, licensing rates shall be established as is current practice for each individual City.

## **2.0 COMPENSATION AND BILLING**

- 2.1 **COMPENSATION.** In consideration for satisfactory and timely performance of all services provided to City under this Agreement, City shall pay Pasadena Humane the monthly amounts specified in Exhibit B. Pasadena Humane will retain 100% of all pet-licensing revenues and retain 100% of any animal impounds fees that Pasadena Humane may collect.
- 2.2 **ADDITIONAL SERVICES.** Pasadena Humane shall retain the proceeds for any additional fees for service.
- 2.3 **METHOD OF BILLING.** Pasadena Humane may submit invoices to City for approval on a progress basis, but no more often than monthly. City shall pay Pasadena Humane's invoice within forty-five (45) days from the date City receives said invoice. Any additional services outside the Scope of Service Exhibit "A" approved and performed pursuant to this Agreement shall be designated as "Additional Services" and shall identify the number of the authorized change order, where applicable, on all invoices.
- 2.4 **RECORDS AND AUDITS.** Financial records of Pasadena Humane's services relating to this Agreement shall be maintained in accordance with generally recognized accounting principles and shall be provided to and made available to City for inspection and/or audit at mutually convenient times for a period of three (3) years from the Effective Date. Pasadena Humane shall provide to the City copies of its audited financial reports, annually, covering the period of this Agreement.

## **3.0 TIME OF PERFORMANCE**

- 3.1 **COMMENCEMENT AND COMPLETION OF WORK.** The professional services to be performed pursuant to this Agreement shall commence from the Effective Date of this Agreement. Failure to commence work in a timely manner and/or diligently pursue work to completion may be grounds for termination of this Agreement.
- 3.2 **EXCUSABLE DELAYS.** Neither party shall be responsible for delays or lack of performance resulting from acts beyond the reasonable control of the party or parties. Such acts shall include, but not be limited to, acts of God, pandemic, fire, strikes, material shortages, compliance with laws or regulations, riots, acts of war, or any other conditions beyond the reasonable control of a party.

#### **4.0 TERM AND TERMINATION**

- 4.1 **TERM.** The services provided pursuant to this Agreement shall begin on the Effective Date and continue for a period of five years, ending June 30, 2031, ("Termination Date"), unless previously terminated as provided herein or as otherwise agreed to in writing by the parties.
- 4.2 **APPOINTMENT.** In accordance with City's Municipal Code , City appoints Pasadena Humane as the Animal Shelter of City for the period beginning on the Effective Date and ending on the Termination Date, and hereby authorizes, directs, and empowers Pasadena Humane to perform during the term of this Agreement all the powers and duties conferred and imposed upon the Shelter Director by the City's Municipal Code, applicable City policies and regulations, and state laws and regulations, as they may be amended from time to time.
- 4.3 **ACCEPTING OF APPOINTMENT.** Pasadena Humane shall during the term of this Agreement perform all the powers and duties conferred and imposed upon the Animal Shelter and Shelter Director, in compliance with all applicable City policies and regulations, and state laws and regulations, as they may be amended from time to time.
- 4.4 **NOTICE OF TERMINATION.** This Agreement may be terminated by either party by giving not less than 90 days written notice to the other party, except as referenced in Section 5.8 of this Agreement. The notice shall state the termination date.
- 4.5 **COMPENSATION.** City shall continue to pay Pasadena Humane pursuant to section 2.1 of this agreement each month through the termination date.

#### **5.0 INSURANCE**

- 5.1 **MINIMUM SCOPE AND LIMITS OF INSURANCE.** Pasadena Humane shall, at its own cost and expense, promptly secure and maintain during the life of this Agreement the following insurance:
- 5.1.1 Comprehensive general liability insurance on an "occurrence" basis, including premises, operations, products and completed operations, property damage, blanket contractual liability, independent contractors, bodily injury and personal and advertising injury with a policy of not less than Two Million Dollars (\$2,000,000) per occurrence. If a general aggregate limit applies, the general aggregate limit shall be twice the required occurrence limit.

- 5.1.2 Comprehensive automobile liability insurance for any owned, non-owned and hired vehicles used in the connection with the performance of this Agreement with a policy of not less than One Million Dollars (\$1,000,000) per accident for bodily injury and property damage.
  - 5.1.3 Workers' compensation insurance as required by the State of California, with Statutory Limits, and Employer's Liability Insurance with limit of no less than One Million Dollars (\$1,000,000) per accident for bodily injury or disease.
  - 5.1.4 Professional errors and omissions ("E&O") liability insurance with policy limits of not less than Two Million Dollars (\$2,000,000) per occurrence or claim, Two Million Dollars (\$2,000,000) aggregate. Pasadena Humane shall obtain and maintain said E&O liability insurance during the life of this Agreement and for three years after completion of the work hereunder.
- 5.2 If Pasadena Humane maintains broader coverage and/or higher limits than the minimums shown above, the City requires and shall be entitled to the broader coverage and/or the higher limits maintained by Pasadena Humane. Any available insurance proceeds in excess of the specified minimum limits of insurance and coverage shall be available to the City.
- 5.3 ENDORSEMENTS. Each policy of insurance required hereunder shall contain or be endorsed to contain the following:
- 5.3.1 "The City of Arcadia and its elected and appointed boards, officers, officials, agents, employees, and volunteers are additional insureds with respect to this subject project and Agreement with City."
  - 5.3.2 "This policy shall not be cancelled, reduced, or otherwise modified without the insurance carrier giving the City a minimum of thirty (30) days' prior written notice."
  - 5.3.3 "Any other insurance or self-insurance maintained by the City of Arcadia shall be in excess of and not contributing with the insurance provided by this policy."
- 5.4 WAIVER OF SUBROGATION. Pasadena Humane hereby grants City a waiver of any right to subrogation which any insurer of Pasadena Humane may acquire against City by virtue of the payment of any loss under such insurance. Pasadena Humane agrees to obtain any endorsement that may be necessary to affect this waiver of subrogation, but this provision applies regardless of whether or not City has received a waiver of subrogation endorsement from the insurer.

- 5.5 **SELF-INSURED RETENTIONS.** Self-insured retentions must be declared to and approved by City. City may require Pasadena Humane to provide proof of ability to pay losses and related investigations, claim administration, and defense expenses within the retention.
- 5.6 **ACCEPTABILITY OF INSURERS.** Insurance is to be placed with insurers authorized to conduct business in the state with a current A.M. Best's rating of no less than A:VII.
- 5.7 **CERTIFICATES OF INSURANCE.** Pasadena Humane shall submit to City a certificate of insurance and endorsements for each policy not less than one (1) day prior to beginning performance under this Agreement. However, failure to obtain the required documents prior to the work beginning shall not waive Pasadena Humane's obligation to provide them. Each certificate shall be signed by a person authorized by that insurer to bind coverage on its behalf. The certificate(s) must be in a form approved by the City. City may require complete certified copies of any or all policies at any time.
- 5.8 **FAILURE TO MAINTAIN REQUIRED INSURANCE.** Failure to maintain required insurance at all times shall constitute a default and material breach of this Agreement. In such event, Pasadena Humane shall immediately notify City and cease all performance under this Agreement until further directed by City other than caring for animals impounded or quarantined at Pasadena Humane's shelter prior to termination. In the absence of satisfactory insurance coverage, City shall have the option to immediately terminate this Agreement.
- 5.9 **SPECIAL RISKS OR CIRCUMSTANCES.** City reserves the right to modify these requirements, including limits, based on the nature of the risk, prior experience, insurer, coverage, or other special circumstances.
- 5.10 **NON-LIMITING.** Nothing in this Section shall be construed as limiting in any way, the indemnification provision contained in this Agreement.

## **6.0 GENERAL PROVISIONS**

- 6.1 **ENTIRE AGREEMENT.** This Agreement constitutes the entire Agreement between the parties with respect to any matter referenced herein and supersedes any and all other prior writings and oral negotiations. This Agreement may only be modified in writing, and signed by the parties in interest at the time of such modification. The terms of this Agreement shall prevail over any inconsistent provision in any other contract document attached hereto, including exhibits to this Agreement.
- 6.2 **DESIGNATED POINT OF CONTACT.** Pasadena Humane shall designate an individual to be the point of contact for any and all operational issues involving

the City. Pasadena Humane shall provide said individual's contact information, including name and telephone number upon execution of this Agreement. Likewise, the City shall designate an individual to be the point of contact for any and all operational issues involving Pasadena Humane. The City shall provide said individual's contact information, including name and telephone number upon execution of this Agreement.

- 6.3 BUSINESS LICENSE. Pasadena Humane shall maintain a business license as required by the City Municipal Code during the duration of this Agreement and pay any fees related thereto.
- 6.4 This Agreement shall be governed by the laws of the State of California.
- 6.5 NOTICES. Any notices, documents, correspondence or other communications concerning this Agreement or the work hereunder may be provided by personal delivery or mail and shall be addressed as set forth below. Such communication shall be deemed served or delivered: (a) at the time of delivery if such communication is sent by personal delivery; (b) at the time of certified delivery if such communication is sent through regular United States mail.

IF TO CITY:

IF TO PASADENA HUMANE:

Christopher Ramon, President & CEO  
The Pasadena Humane Society  
361 South Raymond Avenue  
Pasadena, CA 91105

- 6.6 ATTORNEY'S FEES. In the event that legal action is necessary to enforce or interpret the provisions of this Agreement, the prevailing party in such action or proceeding shall be entitled to recover its costs of suit, including attorney's fees from the opposing party in any amount determined by the court to be reasonable.
- 6.7 INDEMNIFICATION AND HOLD HARMLESS. Pasadena Humane shall protect, defend, indemnify, and hold harmless City and its elected and appointed officials, officers, and employees from any and all claims, liabilities, expenses, including attorneys' fees, damage to property or injuries to or death of any person or persons or damages of any nature including, but not by way of limitation, all civil claims or workers' compensation claims arising out of or in any way connected with the intentional or negligent acts, error, or omissions of Pasadena Humane, its employees, agents, or subcontractors, including claims arising out of activities on City premises or facilities, in the performance of this Agreement.

- 6.8 **INDEPENDENT CONTRACTOR.** Pasadena Humane is, and shall at all times remain as to City, a wholly independent contractor. Pasadena Humane shall have no power to incur any debt, obligation, or liability on behalf of City or otherwise act on behalf of City as an agent. Neither City nor any of its agents shall have control over the conduct of the Agreement. Pasadena Humane shall not, at any time, or in any manner, represent that it or any of its agents or employees are in any manner agents or employees of City.
- 6.9 **OWNERSHIP OF DOCUMENTS.** All findings, reports, documents, information, and data including, but not limited to, computer hard drives and files furnished or prepared by Pasadena Humane or any of its subcontractors in the course of performance of this Agreement pursuant to the Scope of Services, shall be and remain the sole property of Pasadena Humane. Pasadena Humane agrees that any such documents or information shall be made available to the City for review.
- 6.10 **PUBLIC RECORDS ACT DISCLOSURE.** Pasadena Humane has been advised and is aware that all reports, documents, information and data including, but not limited to, computer tapes, discs, or files furnished or prepared by Pasadena Humane, or any of its subcontractors, and provided to City may be subject to public disclosure as required by the California Public Records Act (California Government Code Section 6250 et. seq.). Exceptions to public disclosure may be those documents or information that qualify as trade secrets, as that term is defined in the California Government Code Section 6254.7, and of which Pasadena Humane informs City of Arcadia of such trade secrets. City will endeavor to maintain as confidential all information obtained by it that is designated as a trade secret. City shall not, in any way, be liable or responsible for the disclosure of any trade secret including, without limitation, those records so marked if disclosure is deemed to be required by law or by order of the Court.
- 6.11 **RESPONSIBILITY FOR ERRORS.** Pasadena Humane shall be responsible for its work and results under this Agreement. Pasadena Humane, when requested, shall furnish clarification and/or explanation as may be required by City, regarding any services rendered under this Agreement at no additional cost to City. In the event that an error or omission attributable to Pasadena Humane occurs, then Pasadena Humane shall, at no cost to City, provide all necessary professional services needed to rectify and correct the matter to the sole satisfaction of City and to participate in any meeting required with regard to the correction.
- 6.12 **PROHIBITED EMPLOYMENT.** Pasadena Humane will not employ any regular employee of City while this Agreement is in effect.
- 6.13 **COSTS.** Each party shall bear its own costs and fees incurred in the preparation and negotiation of this Agreement and in the performance of its obligations hereunder except as expressly provided herein.

- 6.14 **NO THIRD-PARTY BENEFICIARY RIGHTS.** This Agreement is entered into for the sole benefit of City and Pasadena Humane and no other parties are intended to be direct or incidental beneficiaries of this Agreement and no third party shall have any right in, under, or to this Agreement.
- 6.15 **HEADINGS.** Any heading of the several paragraphs of this Agreement is inserted for convenience and reference only and shall not be held or construed in any manner to affect the scope, or to limit or to qualify the meaning or intent of the provisions thereof.
- 6.16 **CONSTRUCTION.** The parties have participated jointly in the negotiation and drafting of this Agreement. In the event an ambiguity or question of intent or interpretation arises with respect to this Agreement, this Agreement shall be construed as if drafted jointly by the parties and in accordance with its fair meaning. There shall be no presumption or burden of proof favoring or disfavoring any party by virtue of the authorship of any of the provisions of this Agreement.
- 6.17 **WAIVER.** The delay or failure of either party at any time to require performance or compliance by the other of any of its obligations or agreements shall in no way be deemed a waiver of those rights to require such performance or compliance. No waiver of any provision of this Agreement shall be effective unless in writing and signed by a duly authorized representative of the party against whom enforcement of a waiver is sought. The waiver of any right or remedy in respect to any occurrence or event shall not be deemed a waiver of any right or remedy in respect to any other occurrence or event, nor shall any waiver constitute a continuing waiver.
- 6.18 **SEVERABILITY.** If any provision of this Agreement is determined by a court of competent jurisdiction to be unenforceable in any circumstance, such determination shall not affect the validity or enforceability of the remaining terms and provisions hereof or of the offending provision in any other circumstance. Notwithstanding the foregoing, if the value of this Agreement, based upon the substantial benefit of the bargain for any party is materially impaired, which determination as made by the presiding court or arbitrator of competent jurisdiction shall be binding, then both parties agree to substitute such provision(s) through good faith negotiations.
- 6.19 **COUNTERPARTS.** This Agreement may be executed in counterparts, each of which so executed shall be deemed an original irrespective of the date of the execution, and said counterparts shall together constitute one and the same agreement.
- 6.20 **CORPORATE AUTHORITY.** The persons executing this Agreement on behalf of the parties hereto warrant that they are duly authorized to execute this Agreement

on behalf of said parties and that by doing so, the parties hereto are formally bound to the provisions of this Agreement.

6.21 ARBITRATION OF DISPUTES. Any dispute for under \$50,000 arising out of or relating to the negotiation, construction, performance, nonperformance, breach or any other aspect of this Agreement, shall be settled by binding arbitration in accordance with the Commercial Rules of the American Arbitration Association at Los Angeles, California and judgment upon the award rendered by the Arbitrators may be entered in any court having jurisdiction thereof. Neither Party waives its right to object to the timeliness or sufficiency of any claim filed or required to be filed against each other. The Parties both reserve the right to conduct full discovery.

**IN WITNESS WHEREOF, the parties hereto have caused the Agreement to be executed by their duly authorized representatives as of the date of the first written above.**

**ATTEST:**

**CITY:**

**BY:** \_\_\_\_\_

**BY:** \_\_\_\_\_

Approved as to Form:

**THE PASADENA HUMANE SOCIETY:**

**BY:** \_\_\_\_\_

**BY:** \_\_\_\_\_

Christopher Ramon, President & CEO

# **PROFESSIONAL SERVICES AGREEMENT FOR ANIMAL SHELTER AND ANIMAL CONTROL SERVICES**

Pasadena Humane / City of Arcadia

## **EXHIBIT A Scope of Services**

Pasadena Humane will provide all staffing, equipment, and supplies needed to provide animal care and control services, which shall include field services, sheltering services, medical services, reporting, community programming and other services described in the sections below.

Pasadena Humane will adhere to all applicable federal, state and local laws, statutes, and ordinances regarding the humane care and treatment of animals.

### **1. Field Services**

Activities involve trained field officers and dispatchers performing a variety of duties utilizing appropriate equipment. Services include:

- a. Receive calls for service 24 hours per day, seven days per week through either Pasadena Humane dispatch or after-hours answering service and dispatch staff for field response as appropriate.
- b. Respond to priority one calls no later than 90 minutes from dispatch, with 80% of all priority one calls responded to within 45 minutes of dispatch, 24 hours per day.

#### **Priority one calls include:**

- i. Seemingly vicious or dangerous animals that pose a public safety threat,
- ii. incidents in which a person has been injured by an animal at large,
- iii. calls regarding sick or injured domestic animals at large or sick or injured wildlife.
- iv. emergency situations that cannot be handled by on-duty police officers requiring animal control assistance,
- v. requests for law enforcement support in cases such as animals of deceased persons or legally detained individuals,
- vi. predatory wildlife which poses a danger to the public until such time as California Fish and Wildlife can respond and clear the call,
- vii. loose livestock,
- viii. pick up of dead animals at the request of a police officer or City official when such service cannot be reasonably delayed until the next normal business day due to exigent circumstances such as public endangerment, attractive nuisance, or a shock to the public, and

- ix. any other clearly exigent circumstance.
- c. Respond to routine calls for service, such as dogs at large, abuse/neglect complaints, within two hours during regular business hours, 8am to 8pm seven days per week. Routine calls received during non-business hours shall be handled by Pasadena Humane during the next business day.
- d. Assist and support the City's law enforcement operations when there may be animal related concerns. This includes but is not limited to providing animal control support during the execution of arrest and search warrants both inside and outside the City limits. A Certified Animal Control Officer shall participate in the pre-warrant briefing in circumstances in which the City anticipates animal related concerns in advance.
- e. Attempt to return lost-owned dogs with discernible form of owner identification to owner, or if owner cannot be located, impound.
- f. Healthy community cats, defined as cats who are free-roaming, or feral, or outdoor barn or working cats who have no discernible form of ownership identification may be accepted for the purpose of spay/neuter, and if deemed appropriate by Pasadena Humane returned to their neighborhood/home territory, commonly referred to as TNRM (trap-neuter-return-monitor);
- g. Remove dead land animals (limited to a maximum of 150 pounds) from public and private property and dispose of these animals within 24 hours during regular business hours of receiving the request, 8am to 8pm seven days per week. Pasadena Humane reserves the right to refrain from entering private property if doing so would be unsafe.
- h. Dispatch an officer to assist with an owned pet surrender when there are exigent circumstances and/or after determining there are no reasonable means for a pet owner to bring their animal to shelter (a reasonable fee may be charged to the pet owner).
- i. Share information with the public to assist community members with resources and tools to improve or maintain the health and welfare of animals in the community.
- j. Enforce all animal related local ordinances, County codes and State laws. Issue administrative or criminal citations as appropriate. City agrees to furnish Pasadena Humane with enough citation forms to perform this service.
- k. Investigate cases for possible criminal prosecution, including misdemeanor and felony crimes. Collect evidence, prepare reports, and testify in court and other hearings if necessary.

- l. Investigate animal nuisance complaints such as excessive barking and other violations. Provide investigative reports to the appropriate City entity for review and appropriate action.
- m. Investigate reports of animal bites and, for City of Arcadia, quarantine animals for rabies observation for ten days from the time of the bite at their owner's residence or pick up and hold the animal in quarantine at the Pasadena Humane shelter in an individual kennel where the animal will not have direct contact with other animals during its quarantine period. For animals outside of Pasadena notify the Los Angeles County Department of Rabies Control program so that their inspectors may quarantine the animal and, if desired, direct Pasadena Humane to house the animal during the quarantine period. If the animal should die during the quarantine period, Pasadena Humane shall immediately contact the presiding Public Health / Department of Health Services, as well as the animal's owner, if known.
- n. To the extent that aid is requested, available and necessary, respond to emergencies such as fires, earthquakes, floods, and other natural or manmade disasters to rescue and temporarily house animals, or to provide care for animals in evacuation zones. Pasadena Humane will not be obligated to provide aid and assistance where such provision would be disproportionately detrimental to the public health, safety or welfare of its employees or the communities it serves.
- o. In the case of an emergency call by the City Police Department to impound a legally detained individual's property, Pasadena Humane may assess a reasonable impoundment fee to the owner of the animal, to be collected at the time of pick-up. If any governmental entity, including the City, requests Pasadena Humane society to impound a particular animal or animals to be held as evidence in a jurisdictional proceeding or for any other purpose, Pasadena Humane may assess a reasonable impound fee to such governmental entity for any impound period for those species of animals not kept, stored, fed, maintained, or housed in the ordinary course or scope of business as an animal shelter (i.e. animals other than dogs, cats, rabbits, or other small pets).
- p. Provide "Directed Patrol Services" as requested by the City, defined as patrol services intended for a specific area or problem for a limited duration for the purpose of addressing enforcement issues relating to animals.
- q. When healthy kittens are found or reported, Pasadena Humane may ask the finding party to monitor the litter and/or ask the finder to foster and/or impound kittens. Any sick, injured or unhealthy kittens will be impounded by Pasadena Humane.

*Please note: Pasadena Humane does not respond to calls regarding healthy non-predatory wildlife.*

## **2. Shelter Services**

Represents services provided by Pasadena Humane to meet the needs of animals collected in the field within the boundaries of the City and animals relinquished or turned in at the Pasadena Humane facility that have originated within the boundaries of the City. Services are dedicated to providing a comfortable and safe environment for all animals admitted regardless of how they came in, when they came in, or their age, health status and behavior, as well as providing accessibility to the public to obtain services and/or reclaim pets. Services include:

- a. Provide food, water, and shelter for impounded animals daily, seven days per week.
- b. Provide species-appropriate sheltering and enrichment to ensure sheltered pets are able to rest comfortably and are free to express normal behavior.
- c. Provide behavior assessment and attempt to remediate problem behaviors.
- d. Attempt to reunite lost pets with their owners.
- e. Make best efforts to place every healthy and safe animal.
- f. Animals found within the City may be turned in by appointment during regular business hours at the Pasadena Humane facility. Members of the public looking to turn in a found animal may, at the discretion of Pasadena Humane, be asked to help locate the owner by, including and not limited to, posting signs, checking with neighbors, utilizing social media, up to when appropriate and safe holding the animal while performing the above actions.
- g. After all other resources or alternatives have been exhausted and when impound is deemed the best agreed upon outcome for community members seeking assistance with their pet, owned animals may be surrendered at the shelter, by appointment based on capacity. Pasadena Humane will make every effort to collect a reasonable fee from owners surrendering their pets.
- h. Where appropriate, healthy cats may be accepted for the purpose of spay/neuter, and if deemed appropriate by Pasadena Humane safely and appropriately returned to their neighborhood/home territory, commonly referred to as TNRM (trap-neuter-return-monitor).
- i. Quarantine and observe animals for rabies and other diseases at the direction of the Department of Public Health.
- j. Provide emergency response to pets displaced by wildfires or other disasters.
- k. Hold animals that are the subject of criminal investigations or other legal or administrative proceedings.

- l. Provide euthanasia services to impounded animals as deemed appropriate.
- m. Properly dispose of deceased animals.
- n. Maintain a website with pictures of impounded and surrendered animals to facilitate reuniting the animals with their owners or finding new adoptive homes.
- o. Return any animal to the animal's owner or return cats to their neighborhood/home territory with or without impoundment if it is deemed by Pasadena Humane to be the best outcome for the animal.
- p. Maintain regular hours of operation for the public seeking an appointment to find a lost pet, impound a found pet, or surrender an owned pet.
- q. Microchip all dogs, cats and rabbits prior to reunification or placement, unless exigent circumstances such as animal illness delay or prevent service.
- r. When healthy kittens are brought to the shelter, Pasadena Humane may ask the finding party to monitor the litter and/or ask the finder to foster and/or impound kittens. Any sick, injured or unhealthy kittens will be impounded by Pasadena Humane.

### **Medical Services**

Represents services dedicated to providing medical services to animals in the shelter.

Services include:

- s. Provide access to licensed veterinary medical care, 24 hours per day, 7 days per week for impounded and sheltered animals.
- t. Provide limited health screening examinations and, if deemed necessary by a shelter veterinarian, treatment to all animals entering the shelter.
- u. Provide core vaccinations to cats and dogs and provide medical care to sheltered animals to ensure freedom from pain, injury or disease, and in accordance with standards of care set by the Association of Shelter Veterinarians Guidelines for Standards of Care in Animal Shelters.
- v. Perform spay and neuter services for all dogs, cats and rabbits, unless a veterinarian certifies that the animal is too sick or injured, or that it would otherwise be detrimental to the health of the animal, to be spayed or neutered.

### **3. Reporting**

To ensure transparency Pasadena Humane will file annual reports to the State as required by law. Pasadena Humane will also provide the City with its audited financial reports covering the terms of this Agreement. The preparer of Pasadena Humane's audited financial reports shall satisfy the City as to the reasonableness, accuracy, and completeness of the audited financial reports.

- a. **Monthly Reporting** - Pasadena Humane will provide the City with a monthly report that includes a summary of operations and activities, including the following:
  - i. Numbers of stray and deceased animals picked up in City
  - ii. Animal control activities by type
  - iii. Number of animal control service calls responded to within the City, including type of service.
  - iv. Impound reports by species, wild and domestic
  - v. Animal intake total broken down by species for stray, seized, surrendered by owner, or otherwise, as well as duration of stay
  - vi. Animal final disposition/outcome broken down by species with an animal description, including returned to owner, adopted, transferred to another agency, returned to field, died or lost in shelter, and euthanized
    - 1. Humane Euthanasia data will include the reason for humane euthanasia.
  - vii. Kennel inventory
  - viii. Summary of licensing outreach activities.
  - ix. Number of low-cost spay and neutering services provided, including species, provided to City residents
  - x. Fee reports itemizing all license, impound, and other fees and penalties collected by Pasadena Humane
- b. **Annual Reporting** - Pasadena Humane will also provide an annual operations report summarizing services performed and operations conducted by Pasadena Humane during the prior year, stratified as to the geographic source of performance factor (i.e., the Cities of Arcadia, Bradbury, La Cañada Flintridge, Monrovia, Pasadena, San Marino, Sierra Madre, and South Pasadena).
- c. **Incident Reporting** - Incident reports, such as allegations of animal bites or “nuisance animal” are provided to the Health Department, City Attorney’s Office, and/or Code Compliance Office (depending on jurisdiction) for consideration of scheduling a hearing.

#### 4. Community Programming & Other Services

Pasadena Humane is a safety net for the community’s animals in need. As such, at no cost to the City, Pasadena Humane shall provide community education and diversion programs to promote: a) companion animals residing in loving families, and b) peaceful co-existence with wildlife. Services will include:

- a. Provide low-cost public spay/neuter, vaccination clinics, and microchipping services.

- b. Based on availability of resources, provide emergency services to pet owners in distress, such as a pet-food pantry and temporary boarding.
  - c. Offer public education in animal behavior and animal training classes.
  - d. Operate humane education programs for youth.
  - e. Offer wildlife education through a variety of platforms.
  - f. As one of only two shelters in Southern California licensed to provide wildlife rehabilitation, offer rehabilitation services to injured and orphaned wildlife when there is a high probability that the animal can successfully be returned for survival in the wild after rehabilitation.
  - g. Issue City animal licenses for rabies vaccinated pets in compliance with terms contained in Professional Services Agreement for Animal Shelter and Animal Control Services.
5. **Fees charged to public** - Pasadena Humane may charge the public fees, or waive fees with the exception of licensing fees, for these services at its sole discretion.
6. **City Promotion of Pasadena Humane programs and services** - City agrees to promote licensing, vaccination, spay/neuter, and microchipping of pets through City channels and forums, including and not limited to social media, website and printed materials at relevant City offices.

# PROFESSIONAL SERVICES AGREEMENT FOR ANIMAL SHELTER AND ANIMAL CONTROL SERVICES

Pasadena Humane / City of Arcadia

## EXHIBIT B Contract Pricing

Monthly amounts in US dollars due and payable on the first of each month for each of the 12 months in each contract year. Year 1 begins on July 1, 2026.

City of:	Year 1	Year 2	Year 3	Year 4	Year 5
	2026-27	2027-28	2028-29	2029-30	2030-31
Arcadia	32,835	34,005	35,218	36,473	37,773
Bradbury	1,181	1,332	1,501	1,693	1,908
La Canada Flintridge	10,055	10,083	10,111	10,139	10,167
Monrovia	24,571	26,527	28,638	30,918	33,379
Pasadena	165,664	169,994	174,437	178,996	183,674
San Marino	8,599	8,903	9,217	9,542	9,879
Sierra Madre	5,174	5,590	6,038	6,524	7,048
South Pasadena	17,377	18,045	18,739	19,459	20,207

**DATE:** June 16, 2026

**TO:** Honorable Mayor and City Council

**FROM:** Henry Chen, Administrative Services Director  
By: Monica Li, Buyer

**SUBJECT:** PROFESSIONAL SERVICES AGREEMENT WITH MARS PRINTING FOR CITYWIDE PRINTING SERVICES FOR A FIVE-YEAR TERM, IN AN AMOUNT NOT TO EXCEED \$180,000 ANNUALLY, WITH THE OPTION OF TWO ONE-YEAR RENEWALS  
**CEQA: Not a Project**  
**Recommendation: Approve**

### **SUMMARY**

On June 4, 2019, the City Council approved a Professional Services Agreement for Citywide printing services with The Workshop, which is due to expire June 30, 2026. The City issued a Request for Proposals (“RFP”) for printing services and received two (2) proposals for consideration. The proposals were reviewed by a five-person committee, composed of representatives from several City departments. Following a careful evaluation of the proposals, Mars Printing was deemed the lowest and most responsive bidder. It is recommended that the City Council authorize the City Manager to execute a Professional Services Agreement with Mars Printing for Citywide printing services for a five-year term, with the option to renew for two additional one-year terms, at an annual cost of \$180,000. It is further recommended that the City Council delegate the authority to approve future extensions under this agreement to the City Manager, without having to return to the City Council for subsequent approval, provided that any changes to the financial terms stay within standard inflationary limits.

## **BACKGROUND**

Citywide printing services have been outsourced by the City of Arcadia for more than 18 years to maximize efficiency and reduce costs. The current agreement with The Workshop is scheduled to expire on June 30, 2026. Under the agreement, various printed materials are produced on an as-needed basis, including the Monthly Hot Sheet, Connection Newsletter, business cards, envelopes, department letterhead, certificates, folders, general forms, brochures, posters, signs, banners, receipt books, carbonless forms, and other promotional materials for City events. Special printing services are also provided as needed.

## **DISCUSSION**

On April 14, 2026, the Request for Proposals (“RFP”) was posted on the City’s website, and a Notice Inviting Proposals was published in accordance with City Council Resolution No. 7483. Requests for proposals were also distributed to 24 prospective vendors. A pre-proposal conference was held on April 23, 2026, during which approximately 95 example documents from various City departments were made available for viewing and inspection by prospective vendors. The pre-proposal conference, held in the City Council Chambers Conference Room, was attended by four (4) vendors: Castle Press, The Workshop, Mars Printing, and Alpha Printing.

A committee composed of representatives from various City departments was established for the evaluation of proposals. On May 14, 2026, two (2) responsive proposals were received by the City from Alpha Printing & Graphics and Mars Printing. A proposal was also submitted by Paydirt Printing Services; however, the proposal was deemed non-responsive due to its incompleteness and because it was not received by the City Clerk’s Office by the established deadline. City staff were subsequently notified that no proposal would be submitted by the incumbent, The Workshop, as business operations are concluding permanently this year.

A table below summarizes the average ranking each proposer received based on the submitted bids. Results of the committee’s evaluation are presented as follows, with each proposal scored out of a maximum of 100 points:

<b>Proposer</b>	<b>TOTAL</b>
Mars Printing	93.2
Alpha Printing & Graphics	86.8

Each proposal was evaluated by the committee based on the proposer's thoroughness and understanding of the scope of work. Additional consideration was given to related experience, references, the quality of the proposals submitted, and the overall costs anticipated over the life of the contract. As specified in the Request for Proposals, all quoted prices were required to include shipping and handling and/or desktop delivery costs, as well as all materials, tools, pickup, labor, equipment, disposal, incidental expenses, necessary supervision, and any other services required for the completion of the deliverables.

Although similar scores were received by both proposers for most evaluation criteria, greater competitiveness was demonstrated by Mars Printing when overall contract costs were considered. Following the calculation of total pricing for the requested sample items, including business cards, letterhead, envelopes, flyers, and other printed materials, pricing submitted by Alpha Printing & Graphics was found to be, on average, 19% higher than pricing submitted by Mars Printing over the five-year contract term. In addition, a higher typesetting and design fee was proposed by Alpha Printing & Graphics, whereas Mars Printing proposed a lower overall fee for services.

Presented below is a schedule of estimated printing costs for a sample of projects that are typically required by the City on an annual basis.

<b>Proposer</b>	<b>Year 1</b>	<b>Year 2</b>	<b>Year 3</b>	<b>Year 4</b>	<b>Year 5</b>	<b>5YR TOTAL</b>
<b>Mars Printing</b>	\$25,264.25	\$26,263.54	\$27,314.07	\$28,406.60	\$29,542.86	<b>\$136,791.32</b>
<b>Alpha Printing &amp; Graphics</b>	\$31,004.40	\$32,285.14	\$33,584.45	\$35,009.48	\$36,535.57	<b>\$168,419.04</b>

Based on the results of the committee's evaluation, it is recommended that the City Council approve an agreement with Mars Printing for the period of July 1, 2026, through June 30, 2031, with the option for two one-year renewal periods thereafter.

## **ENVIRONMENTAL ANALYSIS**

The proposed action does not constitute a project under the California Environmental Quality Act ("CEQA"), as it can be seen with certainty that it will have no impact on the environment.

## **FISCAL IMPACT**

The funding for Citywide printing services is included within each department's operating budget. It is anticipated that the annual costs for general citywide printing services will not exceed \$180,000 annually, including paper and delivery costs.

## **RECOMMENDATION**

It is recommended that the City Council determine this action does not constitute a project under the California Environmental Quality Act ("CEQA"); and approve, authorize, and direct the City Manager to execute a Professional Services Agreement with Mars Printing for Citywide printing services for a five-year term, in an amount not to exceed \$180,000 annually, with the option of two one-year renewals. It is further recommended that the City Council delegate the authority to approve future extensions under this agreement to the City Manager, without having to return to the City Council for subsequent approval, provided that any changes to the financial terms stay within standard inflationary limits.

Approved:



Dominic Lazzaretto  
City Manager

**DATE:** June 16, 2026

**TO:** Honorable Mayor and City Council

**FROM:** Roy Nakamura, Chief of Police  
By: Amber Abeyta, Management Analyst

**SUBJECT:** AMENDMENT TO THE PROFESSIONAL SERVICES AGREEMENT WITH EXECUTIVE INFORMATION SERVICES, INC. FOR PS.NET PUBLIC SAFETY SOFTWARE SYSTEM SUPPORT SERVICES IN THE AMOUNT OF \$53,241  
**CEQA: Not a Project**  
**Recommendation: Approve**

### **SUMMARY**

The City has a Professional Services Agreement (“Agreement”) with Executive Information Services, Inc. (“EIS”) for support of the PS.NET Public Safety System, which will expire on June 30, 2026. PS.NET is the backbone of the dispatch and records systems used for Police Department operations. It is recommended that the City Council approve, authorize, and direct the City Manager to execute an amendment to the Professional Services Agreement with EIS in the amount of \$53,241, to extend services for an additional year.

### **DISCUSSION**

Since 2003, the City has maintained an Agreement with EIS for public safety software system support services. EIS has the proprietary rights/ownership to the law enforcement software programs used by the Arcadia Police Department. The software programs include Law Records Management; Computer Assisted Dispatch (“CAD”); Report Writing; Mobile Digital Communications; Los Angeles County Interface; and a Customer Service Portal for submitting crime reports online. All these software programs are used to conduct the Department’s daily operations.

The proposed Amendment is \$53,241 and represents an increase of 9% from last year's contract amount of \$48,845. According to EIS, the increase in cost is being driven inflationary pressures. Over the years, EIS has maintained a good relationship with the Department and has been accommodating to its needs and requirements.

It is important to highlight that the Equipment Replacement Budget for Fiscal Year 2026-27 includes funding for a new CAD and Records Management System ("RMS"). The new upgraded system is essential to address both current and future technological requirements and will be acquired in accordance with the City's procurement policy. Given that the procurement and implementation of a new system will take several months, a renewal with EIS is necessary to sustain the existing CAD and RMS. Therefore, it is recommended that the City Council extend the Agreement with EIS for one year.

### **ENVIRONMENTAL ANALYSIS**

The proposed action does not constitute a project under the California Environmental Quality Act ("CEQA"), based on Section 15061(b)(3) of the CEQA Guidelines, as it can be seen with certainty that it will have no impact on the environment.

### **FISCAL IMPACT**

Sufficient funds in the amount of \$53,241 for the amendment to the Professional Services Agreement have been included in the General Fund Operating Budget for Fiscal Year 2026-27.

### **RECOMMENDATION**

It is recommended the City Council determine that this action does not constitute a project under the California Environmental Quality Act ("CEQA"); and approve, authorize, and direct the City Manager to execute an amendment to the Professional Services Agreement with Executive Information Services, Inc. for PS.NET Public Safety Software System Support Services in the amount of \$53,241.

Approved:



Dominic Lazzaretto  
City Manager

Attachment: Proposed Amendment to the Professional Services Agreement

**AMENDMENT NO. 23 TO THE PROFESSIONAL SERVICES  
AGREEMENT FOR PSNET PUBLIC SAFETY SYSTEM PROJECT WITH EXECUTIVE  
INFORMATION SERVICES, INC.**

This Amendment No. 23 ("Amendment No. 23") is hereby entered into by and between the City of Arcadia, a charter city organized under the Constitution and laws of the State of California, and Executive Information Services, a Nevada Corporation, with respect to that certain Professional Services Agreement between the Parties dated July 13, 2004 (the "Agreement").

The Parties agree as follows:

1. Section 3.1.2 of the Agreement, the Term is amended by extending the term from July 1, 2026, through June 30, 2027 (the "Extended Term").
2. Section 3.3.1 of the Agreement, the Compensation is amended for the Extended Term as referenced in the attached Exhibit "C".
3. All of the remaining terms and provisions of the Agreement are hereby reaffirmed.

[SIGNATURES ON NEXT PAGE]

In witness whereof the Parties have executed this Amendment No. 23 on the date set forth below.

**CITY OF ARCADIA**

**EXECUTIVE INFORMATION SERVICES, INC.**

\_\_\_\_\_  
Dominic Lazzaretto  
City Manager

\_\_\_\_\_  
David Hieb  
Vice President, Client Services

Date: \_\_\_\_\_

Date: \_\_\_\_\_

ATTEST:

\_\_\_\_\_  
City Clerk

\_\_\_\_\_  
Justin Davis  
Senior Vice President Operations

APPROVED AS TO FORM:

CONCUR

\_\_\_\_\_  
Michael J. Maurer  
City Attorney

\_\_\_\_\_  
Roy Nakamura  
Chief of Police

**Exhibit "C"**

**COMPENSATION**

The Agreement is amended to provide that the total compensation for the Extend Term from July 1, 2026, through June 30, 2027, shall not exceed fifty three thousand, two hundred forty-one dollars and zero cents (\$53,241.00). A breakdown of the cost is outlined below.

Description	Quantity	Unit Price	Amount
Annual EIS Support	1.00	\$0.00	\$0.00
Law Records Management, CAD: July 2026 to July 2027	1.00	\$51,706.00	\$51,706.00
CAD to LensLock: July 2026 to July 2027	1.00	\$1,535.00	\$1,535.00
		Total	\$53,241.00

**DATE:** June 16, 2026

**TO:** Honorable Mayor and City Council

**FROM:** Roy Nakamura, Chief of Police  
By: Amber Abeyta, Management Analyst

**SUBJECT:** AMENDMENT NO. 2 TO THE PROFESSIONAL SERVICES AGREEMENT WITH ALLIED UNIVERSAL SECURITY SERVICES FOR JAIL OPERATION SERVICES FOR FISCAL YEAR 2026-27, IN AN AMOUNT NOT TO EXCEED \$428,196  
**CEQA: Not a Project**  
**Recommendation: Approve**

### **SUMMARY**

The City has a Professional Services Agreement (“Agreement”) with Allied Universal Security Services (“Allied”) for jail operation services, which expires on June 30, 2026. It is recommended that the City Council approve, authorize, and direct the City Manager to execute Amendment No. 2 to the Agreement with Allied for jail operation services for Fiscal Year 2026-27, in an amount not to exceed \$428,196. It is further recommended that the City Council delegate the authority to approve future renewals under this agreement to the City Manager, without returning to the City Council for approval, provided that any financial increases remain within recognized inflationary levels.

### **BACKGROUND**

The Arcadia Police Department jail is a 20-bed “Type I Jail Facility,” as described in the California Code of Regulations, Title 15. A Type I Jail is a local detention facility where persons are held for not more than 96 hours (excluding holidays) after booking. The jail holds inmates prior to court arraignment and/or pending release on Bail, Own Recognizance, Written Promise to Appear, and prisoner DNA collection. Jail staff is responsible for the safety and well-being of all inmates and adheres to all applicable

Federal and State requirements, laws and statutes, applicable court orders, and the California Corrections Standards Authority, as applicable to a Type I Jail Facility.

Since the inception of the Jail, the Department has maintained a positive reputation for the efficient and effective handling of operations, supervision, and management of the facility. Since 2012, the Department has contracted with a private company for jail services, initially with G4S, which was later acquired by Allied Universal. Allied Universal is a company with over 60 years of experience in providing security services. The jail operation services provided include all labor, tools, equipment, materials, and supervision necessary to provide for a safe, efficient operation of the City's Type I Jail Facility. Over the course of the agreement, Allied and the City have worked together to garner quality jailers who meet the City's employment standards and performance expectations.

## **DISCUSSION**

The previous contract with Allied expired on June 30, 2023. To ensure transparency, a Request for Proposals ("RFP") was issued in March 2023, but Allied was the sole proposer. The Department is aware of one other company that provides jail services, GEO Group, a Florida based company. However, GEO Group did not submit a proposal.

Since Allied's proposal met the City's requirements and they were the only respondent, the contract (Attachment No. 1) was awarded to them and approved by the City Council at the June 20, 2023, meeting. The contract term extended from July 1, 2023, to June 30, 2026, with the option of three one-year renewals. Amendment No. 2 (Attachment No. 2) represents the first one-year renewal, effective July 1, 2026, to June 30, 2027.

The proposed Amendment No. 2 totals \$428,196 (rounded) and represents an increase of 1.84% from last year's contract amount of \$420,464. This slight increase in contract costs for jail operations is attributed to inflationary pressures. All other terms of the Agreement remain the same. Given that Allied has demonstrated reliability as a service provider and consistently meets the City, Federal and State requirements, it is recommended to continue their services for another year.

At the conclusion of FY 2026-27, the agreement will have one final optional extension; if that is approved, a new RFP will be issued during that Fiscal Year for a new contract period.

**ENVIRONMENTAL ANALYSIS**

The proposed action does not constitute a project under the California Environmental Quality Act (“CEQA”), based on Section 15061(b)(3) of the CEQA Guidelines, as it can be seen with certainty that it will have no impact on the environment.

**FISCAL IMPACT**

Sufficient funds in the amount of \$428,196 have been included in the General Fund Operating Budget for Fiscal Year 2026-27.

**RECOMMENDATION**

It is recommended that the City Council determine that this action does not constitute a project under the California Environmental Quality Act (“CEQA”); and approve, authorize, and direct the City Manager to execute Amendment No. 2 to the Professional Services Agreement with Allied Universal Security Services for jail operation services for Fiscal Year 2026-27, in an amount not to exceed \$428,196. It is further recommended that the City Council delegate the authority to approve future renewals under this agreement to the City Manager, without returning to the City Council for approval, provided that any financial increases remain within recognized inflationary levels.

Approved:



Dominic Lazzaretto  
City Manager

Attachment No. 1: Professional Services Agreement  
Attachment No. 2: Proposed Amendment No. 2

**CITY OF ARCADIA  
PROFESSIONAL SERVICES AGREEMENT REGARDING  
OPERATION OF THE ARCADIA POLICE DEPARTMENT'S  
TYPE 1 JAIL FACILITY**

This Agreement is made and entered into as of AUGUST 01, 2023 by and between the City of Arcadia, a municipal corporation organized and operating under the laws of the State of California with its principal place of business at 240 West Huntington Drive, Arcadia, California 91066 ("City"), and Allied Universal Security Services, a Limited Partnership, with its principal place of business at 535 North Brand Boulevard #101, Glendale, California, 91203 (hereinafter referred to as "Consultant"). City and Consultant are sometimes individually referred to as "Party" and collectively as "Parties" in this Agreement.

**RECITALS**

A. City is a public agency of the State of California and is in need of professional services for the following project:

**Type 1 Jail Facilities Operations** (hereinafter referred to as "the Project").

B. Consultant is duly licensed and has the necessary qualifications to provide such services.

C. The Parties desire by this Agreement to establish the terms for City to retain Consultant to provide the services described herein.

**AGREEMENT**

**NOW, THEREFORE, IT IS AGREED AS FOLLOWS:**

1. Services.

Consultant shall provide the City with the services described in the Scope of Services attached hereto as Exhibit "A."

2. Compensation.

a. Subject to paragraph 2(b) below, the City shall pay for such services in accordance with the Schedule of Charges set forth in Exhibit "B."

b. In no event shall the total amount paid for services rendered by Consultant under this Agreement exceed the sum of **one million, two hundred fifteen thousand, three hundred dollars and zero cents (\$1,215,300)** over a three year period as listed in Exhibit "B." This amount is to cover all printing and related costs, and the City will not pay any additional fees for printing expenses. Periodic payments shall be made within 30 days of receipt of an invoice which includes a detailed description of the work performed. Payments to the Consultant for work performed will be made on a monthly billing basis.

3. Additional Work.

If changes in the work seem merited by Consultant or the City, and informal consultations with the other party indicate that a change is warranted, it shall be processed in the following

manner: a letter outlining the changes shall be forwarded to the City by Consultant with a statement of estimated changes in fee or time schedule. An amendment to this Agreement shall be prepared by the City and executed by both Parties before performance of such services, or the City will not be required to pay for the changes in the scope of work. Such amendment shall not render ineffective or invalidate unaffected portions of this Agreement.

4. Maintenance of Records.

Books, documents, papers, accounting records, and other evidence pertaining to costs incurred shall be maintained by Consultant and made available at all reasonable times during the contract period and for four (4) years from the date of final payment under the contract for inspection by City.

5. Term

The term of this Agreement shall be from July 1, 2023, to June 30, 2026, with option of three (3) one (1) year renewals, unless earlier terminated as provided herein. The Parties may, by mutual, written consent, extend the term of this Agreement if necessary to complete the Project. Consultant shall perform its services in a prompt and timely manner within the term of this Agreement and shall commence performance upon receipt of written notice from the City to proceed ("Notice to Proceed").

6. Delays in Performance.

a. Neither City nor Consultant shall be considered in default of this Agreement for delays in performance caused by circumstances beyond the reasonable control of the non-performing party. For purposes of this Agreement, such circumstances include but are not limited to, abnormal weather conditions; floods; earthquakes; fire; epidemics; war; riots and other civil disturbances; strikes, lockouts, work slowdowns, and other labor disturbances; sabotage or judicial restraint.

b. Should such circumstances occur, the non-performing party shall, within a reasonable time of being prevented from performing, give written notice to the other party describing the circumstances preventing continued performance and the efforts being made to resume performance of this Agreement.

7. Compliance with Law.

a. Consultant shall comply with all applicable laws, ordinances, codes and regulations of the federal, state and local government, including Cal/OSHA requirements.

b. If required, the Consultant shall assist the City, as requested, in obtaining and maintaining all permits required of Consultant by federal, state and local regulatory agencies.

c. If applicable, the Consultant is responsible for all costs of clean up and/ or removal of hazardous and toxic substances spilled as a result of his or her services or operations performed under this Agreement.

8. Standard of Care

Consultant's services will be performed in accordance with generally accepted professional practices and principles and in a manner consistent with the level of care and skill ordinarily exercised by members of the profession currently practicing under similar conditions.

9. Assignment and Subconsultant

Consultant shall not assign, sublet, or transfer this Agreement or any rights under or interest in this Agreement without the written consent of the City, which may be withheld for any reason. Any attempt to so assign or so transfer without such consent shall be void and without legal effect and shall constitute grounds for termination. Subcontracts, if any, shall contain a provision making them subject to all provisions stipulated in this Agreement. Nothing contained herein shall prevent Consultant from employing independent associates, and subconsultants as Consultant may deem appropriate to assist in the performance of services hereunder.

10. Independent Contractor

Consultant is retained as an independent contractor and is not an employee of City. No employee or agent of Consultant shall become an employee of the City. The work to be performed shall be in accordance with the work described in this Agreement, subject to such directions and amendments from City as herein provided.

11. Insurance. Consultant shall not commence work for the City until it has provided evidence satisfactory to the City it has secured all insurance required under this section. In addition, Consultant shall not allow any subcontractor to commence work on any subcontract until it has secured all insurance required under this section.

a. Commercial General Liability

(i) The Consultant shall take out and maintain, during the performance of all work under this Agreement, in amounts not less than specified herein, Commercial General Liability Insurance, in a form and with insurance companies acceptable to the City.

(ii) Coverage for Commercial General Liability insurance shall be at least as broad as the following:

(1) Insurance Services Office Commercial General Liability coverage (Occurrence Form CG 00 01) or exact equivalent.

(iii) Commercial General Liability Insurance must include coverage for the following:

- (1) Bodily Injury and Property Damage
- (2) Personal Injury/Advertising Injury
- (3) Premises/Operations Liability
- (4) Products/Completed Operations Liability
- (5) Aggregate Limits that Apply per Project
- (6) Explosion, Collapse and Underground (UCX) exclusion deleted
- (7) Contractual Liability with respect to this Agreement
- (8) Property Damage
- (9) Independent Consultants Coverage

(iv) The policy shall contain no endorsements or provisions limiting coverage for (1) contractual liability; (2) cross liability exclusion for claims or suits by one insured against another; (3) products/completed operations liability; or (4) contain any other exclusion contrary to the Agreement.

(v) The policy shall give the City, its officials, officers, employees, agents and City designated volunteers additional insured status using ISO endorsement forms CG 20 10 10 01 and 20 37 10 01, or endorsements providing the exact same coverage.

(vi) The general liability program may utilize either deductibles or provide coverage excess of a self-insured retention, subject to written approval by the City, and provided that such deductibles shall not apply to the City as an additional insured.

**b. Automobile Liability**

(i) At all times during the performance of the work under this Agreement, the Consultant shall maintain Automobile Liability Insurance for bodily injury and property damage including coverage for owned, non-owned and hired vehicles, in a form and with insurance companies acceptable to the City.

(ii) Coverage for automobile liability insurance shall be at least as broad as Insurance Services Office Form Number CA 00 01 covering automobile liability (Coverage Symbol 1, any auto).

(iii) The policy shall give the City, its officials, officers, employees, agents and City designated volunteers additional insured status.

(iv) Subject to written approval by the City, the automobile liability program may utilize deductibles, provided that such deductibles shall not apply to the City as an additional insured, but not a self-insured retention.

**c. Workers' Compensation/Employer's Liability**

(i) Consultant certifies that he/she is aware of the provisions of Section 3700 of the California Labor Code which requires every employer to be insured against liability for workers' compensation or to undertake self-insurance in accordance with the provisions of that code, and he/she will comply with such provisions before commencing work under this Agreement.

(ii) To the extent Consultant has employees at any time during the term of this Agreement, at all times during the performance of the work under this Agreement, the Consultant shall maintain full compensation insurance for all persons employed directly by him/her to carry out the work contemplated under this Agreement, all in accordance with the "Workers' Compensation and Insurance Act," Division IV of the Labor Code of the State of California and any acts amendatory thereof, and Employer's Liability Coverage in amounts indicated herein. Consultant shall require all subconsultants to obtain and maintain, for the period required by this Agreement, workers' compensation coverage of the same type and limits as specified in this section.

**d. Professional Liability (Errors and Omissions)**

At all times during the performance of the work under this Agreement the Consultant shall

maintain professional liability or Errors and Omissions insurance appropriate to its profession, in a form and with insurance companies acceptable to the City and in an amount indicated herein. This insurance shall be endorsed to include contractual liability applicable to this Agreement and shall be written on a policy form coverage specifically designed to protect against acts, errors or omissions of the Consultant. "Covered Professional Services" as designated in the policy must specifically include work performed under this Agreement. The policy must "pay on behalf of" the insured and must include a provision establishing the insurer's duty to defend.

**e. Minimum Policy Limits Required**

(i) The following insurance limits are required for the Agreement:

Combined Single Limit

Commercial General Liability	\$1,000,000 per occurrence/ \$2,000,000 aggregate for bodily injury, personal injury, and property damage
Automobile Liability	\$1,000,000 per occurrence for bodily injury and property damage
Employer's Liability	\$1,000,000 per occurrence
Professional Liability	\$1,000,000 per claim and aggregate (errors and omissions)

(ii) Defense costs shall be payable in addition to the limits.

(iii) Requirements of specific coverage or limits contained in this section are not intended as a limitation on coverage, limits, or other requirement, or a waiver of any coverage normally provided by any insurance. Any available coverage shall be provided to the parties required to be named as Additional Insured pursuant to this Agreement.

**f. Evidence Required**

Prior to execution of the Agreement, the Consultant shall file with the City evidence of insurance from an insurer or insurers certifying to the coverage of all insurance required herein. Such evidence shall include original copies of the ISO CG 00 01 (or insurer's equivalent) signed by the insurer's representative and Certificate of Insurance (Acord Form 25-S or equivalent), together with required endorsements. All evidence of insurance shall be signed by a properly authorized officer, agent, or qualified representative of the insurer and shall certify the names of the insured, any additional insureds, where appropriate, the type and amount of the insurance, the location and operations to which the insurance applies, and the expiration date of such insurance.

**g. Policy Provisions Required**

(i) Consultant shall provide the City at least thirty (30) days prior written notice of cancellation of any policy required by this Agreement, except that the Consultant shall provide at least ten (10) days prior written notice of cancellation of any such policy due to non-payment of premium. If any of the required coverage is cancelled or expires during the term of this Agreement, the Consultant shall deliver renewal certificate(s) including the General

Liability Additional Insured Endorsement to the City at least ten (10) days prior to the effective date of cancellation or expiration.

(ii) The Commercial General Liability Policy and Automobile Policy shall each contain a provision stating that Consultant's policy is primary insurance and that any insurance, self-insurance or other coverage maintained by the City or any named insureds shall not be called upon to contribute to any loss.

(iii) The retroactive date (if any) of each policy is to be no later than the effective date of this Agreement. Consultant shall maintain such coverage continuously for a period of at least three years after the completion of the work under this Agreement. Consultant shall purchase a one (1) year extended reporting period A) if the retroactive date is advanced past the effective date of this Agreement; B) if the policy is cancelled or not renewed; or C) if the policy is replaced by another claims-made policy with a retroactive date subsequent to the effective date of this Agreement.

(iv) All required insurance coverages, except for the professional liability coverage, shall contain or be endorsed to waiver of subrogation in favor of the City, its officials, officers, employees, agents, and volunteers or shall specifically allow Consultant or others providing insurance evidence in compliance with these specifications to waive their right of recovery prior to a loss. Consultant hereby waives its own right of recovery against City and shall require similar written express waivers and insurance clauses from each of its subconsultants.

(v) The limits set forth herein shall apply separately to each insured against whom claims are made or suits are brought, except with respect to the limits of liability. Further the limits set forth herein shall not be construed to relieve the Consultant from liability in excess of such coverage, nor shall it limit the Consultant's indemnification obligations to the City and shall not preclude the City from taking such other actions available to the City under other provisions of the Agreement or law.

**h. Qualifying Insurers**

(i) All policies required shall be issued by acceptable insurance companies, as determined by the City, which satisfy the following minimum requirements:

(1) Each such policy shall be from a company or companies with a current A.M. Best's rating of no less than A: VII and admitted to transact in the business of insurance in the State of California, or otherwise allowed to place insurance through surplus line brokers under applicable provisions of the California Insurance Code or any federal law.

**i. Additional Insurance Provisions**

(i) The foregoing requirements as to the types and limits of insurance coverage to be maintained by Consultant, and any approval of said insurance by the City, is not intended to and shall not in any manner limit or qualify the liabilities and obligations otherwise assumed by the Consultant pursuant to this Agreement, including but not limited to, the provisions concerning indemnification.

(ii) If at any time during the life of the Agreement, any policy of insurance required under this Agreement does not comply with these specifications or is

canceled and not replaced, City has the right but not the duty to obtain the insurance it deems necessary, and any premium paid by City will be promptly reimbursed by Consultant or City will withhold amounts sufficient to pay premium from Consultant payments. In the alternative, City may cancel this Agreement.

(iii) The City may require the Consultant to provide complete copies of all insurance policies in effect for the duration of the Project.

(iv) Neither the City nor any of its officials, officers, employees, agents or volunteers shall be personally responsible for any liability arising under or by virtue of this Agreement.

j. Subconsultant Insurance Requirements. Consultant shall not allow any subcontractors or subconsultants to commence work on any subcontract until they have provided evidence satisfactory to the City that they have secured all insurance required under this section. Policies of commercial general liability insurance provided by such subcontractors or subconsultants shall be endorsed to name the City as an additional insured using ISO form CG 20 38 04 13 or an endorsement providing the exact same coverage. If requested by the Consultant, City may approve different scopes or minimum limits of insurance for particular subcontractors or subconsultants.

## 12. Indemnification.

a. To the fullest extent permitted by law, Consultant shall defend (with counsel of City's choosing), indemnify and hold the City, its officials, officers, employees, volunteers, and agents free and harmless from any and all claims, demands, causes of action, costs, expenses, liability, loss, damage or injury of any kind, in law or equity, to property or persons, including wrongful death, in any manner arising out of, pertaining to, or incident to any acts, errors or omissions, or willful misconduct of Consultant, its officials, officers, employees, subcontractors, consultants or agents in connection with the performance of the Consultant's services, the Project or this Agreement, including without limitation the payment of all damages, expert witness fees and attorney's fees and other related costs and expenses. Consultant's obligation to indemnify shall not be restricted to insurance proceeds, if any, received by Consultant, the City, its officials, officers, employees, agents, or volunteers.

b. To the extent required by Civil Code section 2782.8, which is fully incorporated herein, Consultant's obligations under the above indemnity shall be limited to claims that arise out of, pertain to, or relate to the negligence, recklessness, or willful misconduct of the Consultant, but shall not otherwise be reduced. If Consultant's obligations to defend, indemnify, and/or hold harmless arise out of Consultant's performance of "design professional services" (as that term is defined under Civil Code section 2782.8), then upon Consultant obtaining a final adjudication that liability under a claim is caused by the comparative active negligence or willful misconduct of the City, Consultant's obligations shall be reduced in proportion to the established comparative liability of the City and shall not exceed the Consultant's proportionate percentage of fault.

## 13. California Labor Code Requirements.

a. Consultant is aware of the requirements of California Labor Code Sections 1720 et seq. and 1770 et seq., which require the payment of prevailing wage rates and the performance of other requirements on certain "public works" and "maintenance" projects

("Prevailing Wage Laws"). If the services are being performed as part of an applicable "public works" or "maintenance" project, as defined by the Prevailing Wage Laws, and if the total compensation is \$15,000 or more for maintenance or \$25,000 or more for construction, alteration, demolition, installation, or repair, Consultant agrees to fully comply with such Prevailing Wage Laws. Consultant shall defend, indemnify and hold the City, its officials, officers, employees and agents free and harmless from any claims, liabilities, costs, penalties or interest arising out of any failure or alleged failure to comply with the Prevailing Wage Laws. It shall be mandatory upon the Consultant and all subconsultants to comply with all California Labor Code provisions, which include but are not limited to prevailing wages (Labor Code Sections 1771, 1774 and 1775), employment of apprentices (Labor Code Section 1777.5), certified payroll records (Labor Code Sections 1771.4 and 1776), hours of labor (Labor Code Sections 1813 and 1815) and debarment of contractors and subcontractors (Labor Code Section 1777.1).

b. If the services are being performed as part of an applicable "public works" or "maintenance" project and if the total compensation is \$15,000 or more for maintenance or \$25,000 or more for construction, alteration, demolition, installation, or repair, then pursuant to Labor Code Sections 1725.5 and 1771.1, the Consultant and all subconsultants performing such services must be registered with the Department of Industrial Relations. Consultant shall maintain registration for the duration of the Project and require the same of any subconsultants, as applicable. This Project may also be subject to compliance monitoring and enforcement by the Department of Industrial Relations. It shall be Consultant's sole responsibility to comply with all applicable registration and labor compliance requirements.

c. This Agreement may also be subject to compliance monitoring and enforcement by the Department of Industrial Relations. It shall be Consultant's sole responsibility to comply with all applicable registration and labor compliance requirements. Any stop orders issued by the Department of Industrial Relations against Consultant or any subcontractor that affect Consultant's performance of services, including any delay, shall be Consultant's sole responsibility. Any delay arising out of or resulting from such stop orders shall be considered Consultant caused delay and shall not be compensable by the City. Consultant shall defend, indemnify and hold the City, its officials, officers, employees and agents free and harmless from any claim or liability arising out of stop orders issued by the Department of Industrial Relations against Consultant or any subcontractor.

---

14. Verification of Employment Eligibility.

By executing this Agreement, Consultant verifies that it fully complies with all requirements and restrictions of state and federal law respecting the employment of undocumented aliens, including, but not limited to, the Immigration Reform and Control Act of 1986, as may be amended from time to time, and shall require all subconsultants and sub-subconsultants to comply with the same.

15. Laws and Venue.

This Agreement shall be interpreted in accordance with the laws of the State of California. If any action is brought to interpret or enforce any term of this Agreement, the action shall be brought in a state or federal court situated in the County of Los Angeles, State of California.

16. Termination or Abandonment

a. City has the right to terminate or abandon any portion or all of the work under this Agreement by giving ten (10) calendar days written notice to Consultant. In such an event, City shall be immediately given title and possession to all original field notes, drawings and specifications, written reports and other documents produced or developed for that portion of the work completed and/or being abandoned. The city shall pay Consultant the reasonable value of services rendered for any portion of the work completed prior to termination. If said termination occurs prior to completion of any task for the Project for which a payment request has not been received, the charge for services performed during such task shall be the reasonable value of such services, based on an amount mutually agreed to by City and Consultant of the portion of such task completed but not paid prior to said termination. The city shall not be liable for any costs other than the charges or portions thereof which are specified herein. The consultant shall not be entitled to payment for unperformed services, and shall not be entitled to damages or compensation for termination of work.

b. Consultant may terminate its obligation to provide further services under this Agreement upon thirty (30) calendar days' written notice to City only in the event of substantial failure by City to perform in accordance with the terms of this Agreement through no fault of Consultant.

17 Documents. Except as otherwise provided in "Termination or Abandonment," above, all original field notes, written reports, Drawings and Specifications and other documents, produced or developed for the Project shall, upon payment in full for the services described in this Agreement, be furnished to and become the property of the City.

18. Organization

Consultant shall assign Blanal Cook as Project Manager. The Project Manager shall not be removed from the Project or reassigned without the prior written consent of the City.

20. Limitation of Agreement.

This Agreement is limited to and includes only the work included in the Project described above.

21. Notice

Any notice or instrument required to be given or delivered by this Agreement may be given or delivered by depositing the same in any United States Post Office, certified mail, return receipt requested, postage prepaid, addressed to:

CITY:  
City of Arcadia  
240 West Huntington Drive  
Arcadia, CA 91066  
Attn: Chief of Police

CONSULTANT:  
Allied Universal Security Services  
535 N. Brand Blvd., #101  
Glendale, CA 91203  
Attn: Richard Dirmandzhyan

and shall be effective upon receipt thereof.

22. Third Party Rights

Nothing in this Agreement shall be construed to give any rights or benefits to anyone other than the City and the Consultant.

23. Equal Opportunity Employment

Consultant represents that it is an equal opportunity employer and that it shall not discriminate against any employee or applicant for employment because of race, religion, color, national origin, ancestry, sex, age or other interests protected by the State or Federal Constitutions. Such non-discrimination shall include, but not be limited to, all activities related to initial employment, upgrading, demotion, transfer, recruitment or recruitment advertising, layoff or termination.

24. Entire Agreement

This Agreement, with its exhibits, represents the entire understanding of City and Consultant as to those matters contained herein, and supersedes and cancels any prior or contemporaneous oral or written understanding, promises or representations with respect to those matters covered hereunder. Each party acknowledges that no representations, inducements, promises or agreements have been made by any person which are not incorporated herein, and that any other agreements shall be void. This Agreement may not be modified or altered except in writing signed by both Parties hereto. This is an integrated Agreement.

25. Severability

The unenforceability, invalidity or illegality of any provision(s) of this Agreement shall not render the provisions unenforceable, invalid or illegal.

26. Successors and Assigns

This Agreement shall be binding upon and shall endure to the benefit of the successors in interest, executors, administrators and assigns of each party to this Agreement. However, Consultant shall not assign or transfer by operation of law or otherwise any or all of its rights, burdens, duties or obligations without the prior written consent of City. Any attempted assignment without such consent shall be invalid and void.

27. Non-Waiver

None of the provisions of this Agreement shall be considered waived by either party, unless such waiver is specifically specified in writing.

28. Time of Essence

Time is of the essence for each and every provision of this Agreement.

29. City's Right to Employ Other Consultants

The City reserves its right to employ other consultants, including engineers, in connection with this Project or other projects.

30. Prohibited Interests

Consultant maintains and warrants that it has not employed nor retained any company or person, other than a bona fide employee working solely for Consultant, to solicit or secure this Agreement. Further, Consultant warrants that it has not paid, nor has it agreed to pay any company or person, other than a bona fide employee working solely for Consultant, any fee, commission, percentage, brokerage fee, gift or other consideration contingent upon or resulting from the award or making of this Agreement. For breach or violation of this warranty, City shall have the right to rescind this Agreement without liability. For the term of this Agreement, no director, official, officer or employee of City, during the term of his or her service with City, shall have any direct interest in this Agreement, or obtain any present or anticipated material benefit arising therefrom.

**[SIGNATURES ON FOLLOWING PAGE]**

**SIGNATURE PAGE FOR PROFESSIONAL SERVICES AGREEMENT  
BETWEEN THE CITY OF ARCADIA  
AND ALLIED UNIVERSAL SECURITY SERVICES**

IN WITNESS WHEREOF, the Parties have executed this Agreement as of the date first written above.

CITY OF ARCADIA

ALLIED UNIVERSAL SECURITY SERVICES

By:   
Dominic Lazzaretto  
City Manager

By:   
Richard Dirmanzhyan  
General Manager

Date: August 8, 2023

ATTEST:

By:   
Steve Claton  
President

By:   
Nichelle Allen - Assistant  
City Clerk

Date: 7/27/23

APPROVED AS TO FORM

CONUR:

By:   
Michael J. Maurer  
City Attorney

  
Roy Nakamura  
Chief of Police

## EXHIBIT A

### Scope of Services

#### I. SUMMARY

The Arcadia Police Department's Type I Jail Facility is located at the Arcadia Police Department, 250 W. Huntington Drive, Arcadia, CA. The facility consists of 20 beds, three holding cells, and two sobering cells. The facility is staffed twenty-four hours per day, seven days per week, and 365 per days year.

#### II. GENERAL INFORMATION

The services provided by the Consultant shall comply with all applicable Minimum Standards specified by all applicable Federal and State requirements, laws and statutes, applicable court orders and the California Corrections Standards Authority, whether now in effect, hereafter affected or implemented as applicable to Type I Jail Facilities in the future. Services are to include all required supervision, labor, clothing, associated equipment and material needed to effectively and efficiently perform all duties required of a Type I Jail Facility including, but not limited, to any mandatory staff training.

Consultant must be duly licensed in accordance with all security industry requirements for the State of California. Custody Officer services shall be provided seven-days per week, twenty-four hours per day, and 365 days per year.

#### III. PROJECT INTENT

The service provided under these specifications shall be of the highest possible caliber. The consultant's personnel shall be qualified, professional and supervised by knowledgeable, attentive management, who shall be available on a twenty-four hour, seven-day a week basis. The Consultant shall pay particular attention to its procedures for hiring, training, and providing directions to the individual Custody Officers assigned to the City.

#### ~~IV. ARCADIA POLICE TYPE I JAIL FACILITY OPERATIONS~~

The Custody Officers' responsibilities are to include, but are not limited to, receiving, processing, detaining, monitoring, transporting and/or releasing adults and juveniles arrested or detained by officers of the Arcadia Police Department, and performing other related duties as outlined in the Arcadia Police Department Manual and the Arcadia Police Department Jail Manual.

These specifications are intended for uniformed, unarmed, and commissioned or non-commissioned Custody Officers to be provided at the Arcadia Police Department's Type I Jail Facility on a seven-day per week, twenty-four hour per day schedule.

#### CONSULTANT RESPONSIBILITY

Consultant will be responsible for, but not limited to the following:

#### V. STAFFING REQUIREMENTS

- A. **Supervisor:** The Consultant shall designate one (1) Custody Officer position as the Supervisor. The responsibilities of this position shall include direct supervision of custody personnel and the coordination of custody operations and training on all shifts. In addition, the position is responsible for scheduling, record keeping, safety and equipment inspections, facility inspections by governing entities and enforcement of all applicable Local, Federal and State laws, Department policies and mandates. The City's representative must approve of all persons initially selected to fill this position and all future Supervisor positions prior to their commencing work on-site. The Supervisor must be able to perform the duties of the Custody Officer and possess a working knowledge of the laws governing the operation of a Type I Jail Facility. The Supervisor must have a minimum of three years of prior experience with a similar facility.
- B. **Custody Officer:** The Custody Officer shall either be a graduate of an accredited high school or equivalent, with a diploma or GED or meet at least one of the following qualifications:
- Former Public Law Enforcement
  - Former Federal Law Enforcement
  - Police Academy Graduate
  - Former Military Police
  - Former Corrections Officer
  - Former Elite Military Forces and related Combat Arms

The Custody Officer shall:

1. Be either commissioned or non-commissioned in the State of California.
2. Be at least 21-years of age.
3. Have a High School Diploma/GED.
4. Have a valid California Class C driver's license.
5. Must meet all minimum screening and background checks required for Custody Officers.
6. Must complete required training and orientation mandated in this agreement for Custody Officers.
7. Be First Aid and CPR trained and qualified.
8. Have good written and oral communication skills.
9. Be able to prepare written and/or computer-based daily logs and reports of incidents that have taken place.
10. Be responsible for prisoner tracking and booking information.
11. Have a professional appearance like sworn officers in accordance with the Arcadia Police Department manual.
12. Be physically able to perform all aspects of the assignment.
13. Provide favorable references from previous employers.
14. Have an acceptable prior military check of DD form 214 (if applicable).
15. Have a current social security card.
16. Have a current green card (if applicable).
17. Be willing to take a drug test at any time and pass.
18. Personnel to be considered for Custody Officer service shall receive an initial screening and background check by Consultant at no additional charge to the City. Selection of Custody Officer personnel shall include consideration of character traits, motivation, and ability to perform the mental and physical tasks normally required of Custody Officer personnel.

19. After thorough screening and interviewing by the Consultant, the applicant shall be interviewed by a representative of the City, and the City will have final approval of personnel initially assigned to the City and any/all future Custody Officer positions resulting from a vacancy.
20. Consultant shall institute a procedure for performing background checks. The following are the minimum requirements that must be met, and written documentation provided to the City. All information, documentation, testing, certification, etc. is to be conducted and provided at no cost to the City of Arcadia Police Department. By responding to this Request for Proposal you agree to absorb any/all costs associated with these requirements.
  - a. **Employment/Qualifications Verification:** Conduct a seven (7) year employer background check to verify the applicant was not terminated for other than honorable circumstances and verify any periods of unemployment.
  - b. **Education:** Conduct a review of the schools attended by the applicant to verify completed educational level. Validate all references made to completing an "Equivalency Test" for High School level.
  - c. **Drugs:** Conduct a drug screening test to verify non-usage of drugs. Applicants who are narcotics offenders or use dangerous drugs or use alcohol to an excessive degree will be disqualified.
  - d. **Reference Check:** Conduct a minimum of two personal reference checks.
  - e. **DMV Check:** Verify that the applicant has a driving record that reflects reasonable care and judgment. There should be no convictions for moving violations showing disregard for public safety.
  - f. **Criminal History:** Conduct a local criminal history check to verify the applicant has no felony convictions. Additionally, the applicant must pass the Live Scan finger printing process.
  - g. **Wants and/or Warrants:** Applicant must be clear of any outstanding warrants, any prior felony arrests and any crime involving moral turpitude within seven (7) years preceding the date of the application. The applicant may not be on probation or parole for any offense.
  - h. **Credit Check:** Conduct a standard credit check to determine financial responsibility and interview all raters who have given a negative review.
  - i. **Psychological Review:** All Custody Officers must be found to be free from any emotional or mental condition which might adversely affect the exercise of their duties as determined by a licensed psychologist who has a doctoral degree in psychology and at least five years of postgraduate experience in the diagnosis and treatment of emotional and mental disorders. The Custody Officer must be found to be free from job-relevant psychopathology, including personality disorders, and a minimum of two objectively scored psychological tests must be used to assess psychological suitability, one normed in such a manner as to identify patterns of abnormal behavior and the other geared toward assessing dimensions of normal behavior. A clinical interview is also required if the test results are inconclusive or suggest that the candidate should be disqualified.
21. The results of background checks must be furnished to the City representative at least 24 hours prior to the time the applicant is sent for interview.

22. No Custody Officer working for the Consultant will be allowed to work at the City's Jail Facility unless he/she is approved by the City. Consultant shall submit and maintain a list of all employees that have been cleared and are, or will be, assigned to the Arcadia Police Department's Type I Jail Facility. Consultant must provide the names of all employees who will be on site on a daily basis and the names of at least two (2) employees who will fill any potential vacancies regardless of the reason for the absence or vacancy. Employment applications for each employee will also be submitted to the City. In addition, the Consultant shall maintain the availability of at least two (2) additional trained officers for temporary deployment when needed to fill any vacancy within two hours. The City is not responsible for any potential "on-call" costs.
23. Custody Officer personnel shall be trained, uniformed and supervised. Consultant shall provide the uniform and all other items of clothing and apparel as required. Uniforms are to be at the City's election.
24. Upon termination of a Custody Officer, all keys, fobs, identification badges, gate remotes, and parking passes will be recovered from such Custody Officer by Consultant. All items belonging to the City will be turned in immediately upon termination and not be re-issued to any other employees.
25. If awarded this contract you agree to remove immediately all employees, at any location, who fail to follow established Department or State procedures and/or who are deemed by the City to be unfit to perform assigned tasks.

## VI. TRAINING

The law requires privately operated Jails to train personnel in accordance with the training standards established by regulations adopted by the CSA (Corrections Standards Authority) as set forth in Subchapter 1 (commencing with Section 100) of Chapter 1, Division 1, of Title 15 CCR, Standards and Training for Corrections (STC). Proof of such training must be provided upon request.

**A. Supervisor:** The Supervisor shall complete all training requirements, as outlined in Title 15, Article 3. TRAINING, PERSONNEL, AND MANAGEMENT, Section 1021. Additionally, the Supervisor shall receive 24 hours of STC refresher training on an annual basis. The Supervisor shall also receive the Incident Command System 200 and 800 training.

**B. Custody Officer:** The Custody Officer shall complete all training requirements, as outlined in Title 15, Article 3. TRAINING, PERSONNEL, AND MANAGEMENT, Section 1020. Corrections Officer Core Course. Additionally, the Custody Officer shall receive 24-hours of STC refresher training, on an annual basis. The Custody Officer shall also receive the Incident Command System 200 and 800 training.

Moreover, upon employment, in addition to maintaining First Aid and CPR certification for all Custody Officers, Consultant shall provide, at its own expense, a City approved Initial Training program consisting of approximately 50-hours of instruction material taken from the Arcadia Police Department Jail Manual plus sufficient on-going training to ensure Custody Officers remain up to date with changes in custody operations and safety issues. The general categories of instruction shall include:

1. Orientation to the City of Arcadia Police Department
2. Operation liabilities
3. Minimum standards

4. Classification and segregation of inmates
5. Emergency procedures
6. Suicide prevention
7. Fire safety
8. Transportation of prisoners
9. Booking and release procedures, which include Live scan
10. Security and control
11. Reports and data entry
12. Handling confidential information
13. Court testimony
14. Sexual Harassment
15. Violence in the Workplace
16. All Custody Officers shall complete eight hours of specialized training required by Title 15 and Title 24, California Code of Regulations. Such training shall include, but not be limited to:
  - a. Applicable minimum Jail standards
  - b. Jail operations liability
  - c. Inmate segregation
  - d. Emergency procedures and planning
  - e. Suicide prevention
    1. Such training shall be completed as soon as practical, but in any event not more than six months after the date of assigned responsibility. Eight hours of refresher training shall be completed once every two (2) years. In accordance with the initial training, Consultant will continue to provide on-going training. All necessary training will be provided at Consultant's expense. The Supervisor shall record and retain a copy of each employee's training record on site for inspection by the City's representative.

## VII. SCHEDULING REQUIREMENTS

1. The Consultant must maintain at all times, an adequate number of qualified personnel to perform the Custody Officer requirements. The consultant will fill any absence or vacancy immediately to ensure that minimum staffing is retained at all times.
2. The Consultant is required to provide additional staffing for events such as checkpoints, special holidays, etc. as requested on an as needed basis. The exact hours and shifts shall be determined by the City and reported to the Consultant. Sufficient notice shall be given to the Consultant to allow for the appropriate scheduling.
3. Consultant agrees to staff the Arcadia Police Department Type I Jail Facility with qualified, unarmed, uniformed, and trained personnel sufficient to maintain staffing year-round, 24-hours per day, seven-days per week, and 365-days per year. Specific schedules will be determined by the needs of the City.
4. Consultant will provide adequate staffing to facilitate the booking, housing, transportation, and other associated tasks that go along with processing the aforementioned volume of inmates.

## VIII. UNIFORMS

Consultant must provide, at no cost to the City of Arcadia Police Department, all necessary uniforms, associated uniform articles of clothing agreed upon by both parties and equipment, including, but not limited to, utility belts, handcuff holders, keepers, key ring, etc.

#### **IX. SECURITY AND CONTROL**

Consultant is responsible for providing prisoner security within the Arcadia Police Department's Type I Jail Facility and during transportation by Consultant personnel in accordance with applicable Minimum Standards specified by all applicable Federal and State requirements, laws and statutes, applicable court orders and the California Corrections Standards Authority, whether now in effect or hereafter affected or implemented as applicable to the Type I Jail Facility and the Arcadia Police Department Manual and Arcadia Police Department Jail Manual. Regular security inspections of the facility and prisoners will be conducted and documented as required by the City or by the law. The Consultant's security measures may be reviewed on a regular basis to include facility control, internal and external security, search and seizure practices, and emergency procedures.

#### **X. EMERGENCY PROCEDURES**

The City Jail has in place procedures to follow in the event of an emergency outlined in the attached Jail Manual, and shall be adhered to by the Consultant's staff.

#### **XI. USE OF FORCE**

The City Jail has a use-of-force policy in place. The Consultant shall follow policy and report all incidents according to the policy and mandates and provide all associated written reports in a timely manner to the City.

#### **XII. RECORDS**

Consultant is responsible for the timely completion of all inmate and related records as required by the City and applicable Minimum Standards specified by all applicable Federal and State requirements, laws and statutes, applicable court orders and the California Corrections Standards Authority, whether now in effect or hereafter affected or implemented as applicable to the Type I Jail Facility. Consultant shall be responsible for maintaining all related records in compliance with all County and State regulations and inspections. All such records will become, and will remain, the property of the City of Arcadia.

#### **XIII. RISK MANAGEMENT**

Consultant is responsible for identifying risk and exposures and the implementation of a risk management program to deal effectively with them. Major emphasis should be placed upon personal safety, control and search procedures, and biohazard issues related to the handling of the prisoners. Custody Supervisor shall be present during all facility inspections and audits conducted by governing entities.

#### **XIV. HEALTH AND SAFETY**

Consultant shall operate the Arcadia Police Department Type I Jail Facility in compliance with all applicable Minimum Standards specified by all applicable Federal and State requirements, laws and statutes, applicable court orders and the California Corrections Standards Authority, whether

now in effect or hereafter affected or implemented, relative to safety and general operations. Regular safety inspections will be conducted and documented as required by the City. The Consultant will retain on file all completed inspection forms and other related documents for review.

#### **XV. MAINTENANCE OF TYPE I JAIL FACILITY**

Consultant is responsible for maintaining the cleanliness and sanitation of the Arcadia Police Department Type I Jail Facility as required by the Department and County Health Standards. The Supervisor will make available weekly a list of supplies that need to be provided to carry out the duties and maintenance associated with the Arcadia Police Department's Type I Jail Facility. The Consultant shall maintain a record of all maintenance activity and provide a copy to the City and/or appropriate inspection authorities upon request.

#### **XVI. USE OF TYPE I JAIL FACILITY**

The Jail facility building will not be used as a training site for employees of Consultant destined for assignment to other accounts/locations.

#### **XVII. SANITATION AND HYGIENE**

The Consultant shall provide equipment and supplies to ensure a clean and healthy environment at all times. Hygiene items must be provided to inmates for their personal use as mandated by law.

#### **XVIII. FOOD SERVICES**

The Consultant's staff will be responsible for serving food to all inmates. The meals will be arranged and provided by the City at the City of Arcadia's expense and shall adhere to the applicable Minimum Standards specified by all applicable Federal and State requirements, laws and statutes, applicable court orders and the California Corrections Standards Authority, whether now in effect or hereafter affected or implemented as applicable to the Type I Jail Facility and the Arcadia Police Department Manual and Arcadia Police Department Jail Manual.

#### **XIX. PROPERTY**

The Consultant will provide for the secure storage of Inmate personal property. If the property is lost or damaged while under the care of the facility, inmates can use the facility's grievance process to seek reimbursement for the lost or damaged property. Consultant will be directly responsible for any lost or damaged property if it is determined to be the Consultant's responsibility.

#### **XX. GRIEVANCE PROCEDURE**

The Consultant shall allow inmates access to a reasonable, impartial, and nondiscriminatory procedure, which includes a final level of appeal to the State. The Consultant's Facility Operator is responsible for responding to grievances on matters occurring during the inmate's incarceration in the City Jail.

#### **XXI. INMATE SERVICES**

The Consultant will be responsible for supplying, at their expense, and providing all required bedding materials as mandated through Minimum Standards specified by all applicable Federal and State requirements, laws and statutes, applicable court orders and the California Corrections Standards Authority, whether now in effect or hereafter affected or implemented as applicable to the Type I Jail Facility and the Arcadia Police Department Manual and Arcadia Police Department Jail Manual.

#### **XXII. CORRESPONDENCE**

The Consultant shall allow inmates telecommunication access with Minimum Standards specified by all applicable Federal and State requirements, laws and statutes, applicable court orders and the California Corrections Standards Authority, whether now in effect or hereafter affected or implemented as applicable to the Type I Jail Facility and the Arcadia Police Department Manual and Arcadia Police Department Jail Manual. The inmate telecommunications services, which include City owned telephones required for use as outlined in section 851.5 of the California Penal Code, and the payphones inside each regular housing cell, will be provided, maintained, and serviced, at the expense of the City.

#### **XXIII. MEDICAL ATTENTION AND MEDICAL CLEARANCES**

Consultant's staff shall ensure that a full medical screening questionnaire is filled out, from the onset of the booking process, for each inmate screened in the pre-booking process. If there is medical concern(s) that would preclude the booking of an inmate, as outlined in the Jail Manual, the booking will be refused and the arresting officer or transporting officer will be directed to obtain a medical clearance from a licensed physician prior to acceptance of the inmate.

#### **XXIV. I.C.E. LIAISON**

The Consultant shall comply with state laws regarding how the City of Arcadia partners with I.C.E. (Immigrations and Customs Enforcement).

#### **XXV. TRANSPORTATION**

The Consultant will work with the Los Angeles County Sheriff's Department to ensure transportation of inmates scheduled for arraignment is done at a time(s) suitable for a timely appearance(s).

#### **XXVI. ADDITIONAL SERVICES**

From time to time, the City may request additional Custody Officer services beyond that which is specifically set forth herein for such additional work that is mutually agreed upon by the City and Consultant.

#### **XXVII. OVERALL OPERATIONS**

The Consultant, if private, shall operate as a Type I Jail Facility and in compliance with State Statute 6031.6 CPC, which mandates privately operated Jails, under contract to public entities (i.e. counties or cities), to operate in compliance with all appropriate State and Local building, zoning, health, safety, and fire statutes, ordinances and regulations, and with the minimum Jail standards established by regulations adopted by the CSA as set forth in Subchapter 4

**(commencing with Section 1000) of Chapter 1 of Division I of Title 15 CCR. (CSA report, Privately Operated Local Detention Facilities, revised 2/1999)**

**EXHIBIT B**

**21**

Updated Feb. 2020

### Schedule of Charges/Payments

Consultant will invoice the City on a monthly cycle. Consultant will include with each invoice a detailed progress report that indicates the amount of budget spent on each task. Consultant will inform City regarding any out-of-scope work being performed by Consultant.

The total compensation shall not exceed \$1,215,300 over the first three-year period as listed in the table below and as follows:

The total cost for Year 1 (FY 2023-24) shall not exceed \$389,734.

The total cost for Year 2 (FY 2024-25) shall not exceed \$405,095.

The total cost for Year 3 (FY 2025-26) shall not exceed \$420,464.

These rates are subject to review upon renewal at the end of Year 3. The parties will review costs during the City's budget preparation process during the first quart of 2026.

<b>City of Arcadia Police Department</b> Rate Card and Total Spend - Year 1						
Post	Site	HPW	Wage Rate	Bill Rate	Holiday / OT Rate	Annual Cost
Supervisor Custody Officer	Arcadia, CA	40	\$30.00	\$52.20	\$78.30	\$108,576.00
Custody Officer	Arcadia, CA	128	\$24.00	\$41.76	\$62.64	\$277,954.56
<b>Sub-Total</b>		<b>168</b>				<b>\$386,530.56</b>
<b>Direct Bills (Estimate)</b>						<b>Annual Cost</b>
Holidays						\$3,204.00
<b>Sub-Total</b>						<b>\$3,204.00</b>
<b>Grand Total</b>						<b>\$389,734.56</b>

<b>City of Arcadia Police Department</b> Rate Card and Total Spend - Year 2						
Post	Site	HPW	Wage Rate	Bill Rate	Holiday / OT Rate	Annual Cost
Supervisor Custody Officer	Arcadia, CA	40	\$31.00	\$53.94	\$80.91	\$112,195.20
Custody Officer	Arcadia, CA	128	\$25.00	\$43.50	\$65.25	\$289,336.00
<b>Sub-Total</b>		<b>168</b>				<b>\$401,531.20</b>
<b>Direct Bills (Estimate)</b>						<b>Annual Cost</b>
Holidays						\$3,364.20
<b>Sub-Total</b>						<b>\$3,364.20</b>
<b>Grand Total</b>						<b>\$405,095.40</b>

<b>City of Arcadia Police Department</b> Rate Card and Total Spend - Year 3						
Post	Site	HPW	Wage Rate	Bill Rate	Holiday / OT Rate	Annual Cost
Supervisor Custody Officer	Arcadia, CA	40	\$32.00	\$55.68	\$83.52	\$115,814.40
Custody Officer	Arcadia, CA	128	\$26.00	\$45.24	\$67.86	\$301,117.64
<b>Sub-Total</b>		<b>168</b>				<b>\$416,932.04</b>
<b>Direct Bills (Estimate)</b>						<b>Annual Cost</b>
Holidays						\$3,532.41
<b>Sub-Total</b>						<b>\$3,532.41</b>
<b>Grand Total</b>						<b>\$420,464.45</b>

**EXHIBIT C**  
**Activity Schedule**

**Consultant shall staff the Arcadia Police Department's Type 1 Jail Facility with custody officers twenty-four (24) hours per day, seven (7) days per week, and three hundred sixty-five (365) day per year, according to the staffing requirement specifications listed in the Scope of Services – Exhibit "A."**

**AMENDMENT NO. 2 TO PROFESSIONAL SERVICES AGREEMENT REGARDING  
OPERATION OF THE ARCADIA POLICE DEPARTMENT'S TYPE 1 JAIL FACILITY**

This Amendment No. 2 is hereby entered into by and between the City of Arcadia, a charter city organized under the Constitution and laws of the State of California, and Allied Universal Security Services, a Limited Partnership, with respect to that certain Professional Services Agreement between the parties dated August 1, 2023 ("Agreement").

The parties agree as follows:

1. Section 2. (b) Compensation and Exhibit "B" of the Agreement is amended to increase the cost by \$428,196 for the period of July 1, 2026, to June 30, 2027 ("term").
2. Section 5. Term is hereby extended to July 1, 2026, to June 30, 2027.
3. All the remaining terms and provisions of the Agreement are hereby reaffirmed.

In witness whereof the parties have executed this Amendment No. 2 on the date set forth below.

**[SIGNATURES ON FOLLOWING PAGE]**

**CITY OF ARCADIA**

**ALLIED UNIVERSAL**

\_\_\_\_\_  
Dominic Lazzaretto  
City Manager

\_\_\_\_\_  
Richard Dirmandzhuan  
General Manager

Date: \_\_\_\_\_

Date: \_\_\_\_\_

ATTEST:

\_\_\_\_\_  
City Clerk

\_\_\_\_\_  
Steve Claton  
President

Date: \_\_\_\_\_

APPROVED AS TO FORM:

CONCUR:

\_\_\_\_\_  
Michael J. Maurer  
City Attorney

\_\_\_\_\_  
Roy Nakamura  
Chief of Police

EXHIBIT B

Schedule of Charges/Payments

Consultant will invoice the city on a monthly cycle. Consultant will include with each invoice a detailed progress report that indicates the amount of time worked by each employee. Consultant will inform city regarding any out of scope work being performed by consultant.

The total compensation shall not exceed \$428,196 for the term of July 1, 2026, to June 30, 2027, in accordance with the table listed below.



City of Arcadia Police Dept. Jail  
250 W Huntington Dr, Arcadia, CA 91007  
Job #637925

2026-27 Security Budget							
Post	WEEKLY HOURS	PAY RATES	BILL RATES	Overtime/ HOLIDAY RATE	WEEKLY	MONTHLY	ANNUALLY**
Supervisor Custody Officer	40.00	\$33.00	\$57.59	\$86.38	\$2,303.40	\$9,981.40	\$119,776.80
Custody Officer	128.00	\$26.25	\$45.81	\$68.71	\$5,863.20	\$25,407.20	\$304,886.40
<b>TOTAL Hours</b>	<b>168.00</b>						
<b>Total</b>					<b>\$8,166.60</b>	<b>\$35,388.60</b>	<b>\$424,663.20</b>

\* Monthly average based on yearly cost

Direct Bill Items

	Monthly	Annual
Holidays	\$294.37	\$3,532.41
Vehicle (Other Equipment)	\$0.00	\$0.00
Healthcare	\$0.00	\$0.00
<b>Total</b>	<b>\$294.37</b>	<b>\$3,532.41</b>

<b>GRAND TOTAL</b>	<b>\$35,388.60</b>	<b>\$428,195.61</b>
--------------------	--------------------	---------------------

**DATE:** June 16, 2026

**TO:** Honorable Mayor and City Council

**FROM:** Roy Nakamura, Chief of Police  
By: Amber Abeyta, Management Analyst

**SUBJECT:** AMENDMENT NO. 5 TO THE PROFESSIONAL SERVICES AGREEMENT WITH ALL CITY MANAGEMENT SERVICES INC. FOR CROSSING GUARD SERVICES FOR FISCAL YEAR 2026-27, IN AN AMOUNT NOT TO EXCEED \$394,657

**CEQA: Not a Project**

**Recommendation: Approve**

### **SUMMARY**

The City has a Professional Services Agreement (“Agreement”) with All City Management Services Inc. (“ACMS”) for crossing guard services, which expires on June 30, 2026. It is recommended that the City Council approve, authorize, and direct the City Manager to execute Amendment No. 5 to the Professional Services Agreement for crossing guard services with All City Management Services Inc. for Fiscal Year 2026-27, in an amount not to exceed \$394,657. It is further recommended that the City Council delegate the authority to approve future renewals under this agreement to the City Manager, provided that any financial increases remain within recognized inflationary levels.

### **BACKGROUND**

In 2000, as a long-term cost savings strategy, the City opted to enter a Professional Services Agreement with ACMS to provide crossing guards for the City of Arcadia. Since the approval of the Agreement, ACMS has adhered to all conditions and has proven to be a responsible provider.

Before contracting with an external provider, the City managed crossing guard services directly, often needing to fill vacancies due to sickness or injury. For the last

26 years, contracting has eliminated the need for staff involvement and oversight, excluding any contract management duties. This shift has also led to cost savings in worker's compensation insurance and liability management.

ACMS is a full-service contractor that specializes in providing school crossing guard services. The company provides services to handle recruitment, local hiring, background clearance in compliance with Department of Justice standards, initial and ongoing training, payroll and administrative support, coordination of assigning qualified substitutes during absences, local supervision, and communicating with school and site safety inspectors. ACMS has been in business since 1985, are the largest provider of school crossing guard services in the area, and employ over 3,500 crossing guards for over 150 agencies, including 12 local agencies.

## **DISCUSSION**

The previous contract with ACMS expired on June 30, 2022. To ensure transparency, a Request for Proposals ("RFP") was issued on May 16, 2022, with ACMS as the sole proposer. Research indicated that ACMS is the only company consistently responding to local RFPs for crossing guard services in the San Gabriel Valley and is believed to be the only provider in the area.

Since ACMS's proposal met the City's requirements and they were the only proposer, the contract (Attachment No. 1) was awarded to them and approved by the City Council at the August 16, 2022, meeting. The contract term extended from July 1, 2022, to June 30, 2025, with the option of three one-year renewals. Amendment No. 5 (Attachment No. 2), represents the second one-year renewal of the agreement, effective July 1, 2026, to June 30, 2027.

As proposed, Amendment No. 5 totals \$394,657 (rounded), and represents an increase of 4.28% from last year's contract amount of \$378,471. This increase in contract costs for crossing guard services is attributed to inflationary pressures, increased labor costs, and the need to maintain competitive wages to attract and retain qualified personnel. All other terms of the Agreement remain the same. Since ACMS has proven to be a reliable service provider and based on their consistent ability to meet the City's requirements, it is recommended to retain their services for another year.

## **ENVIRONMENTAL ANALYSIS**

The proposed action does not constitute a project under the California Environmental Quality Act ("CEQA"), based on Section 15061(b)(3) of the CEQA Guidelines, as it can be seen with certainty that it will have no impact on the environment.

## **FISCAL IMPACT**

Sufficient funds in the amount of \$394,657 have been included in the General Fund Operating Budget for Fiscal Year 2026-27.

## **RECOMMENDATION**

It is recommended that the City Council determine that this action does not constitute a project under the California Environmental Quality Act ("CEQA"); and approve, authorize, and direct the City Manager to execute Amendment No. 5 to the Professional Services Agreement with All City Management Services Inc. for crossing guard services for Fiscal Year 2026-27, in an amount not to exceed \$394,657. It is further recommended that the City Council delegate the authority to approve future renewals under this agreement to the City Manager, provided that any financial increases remain within recognized inflationary levels.

Approved:



Dominic Lazzaretto  
City Manager

Attachment No. 1: Professional Services Agreement  
Attachment No. 2: Proposed Amendment No. 5

**CITY OF ARCADIA  
PROFESSIONAL SERVICES AGREEMENT REGARDING  
CROSSING GUARD SERVICES**

This Agreement is made and entered into as of August 31, 2027 by and between the City of Arcadia, a municipal corporation organized and operating under the laws of the State of California with its principal place of business at 240 West Huntington Drive, Arcadia, California 91066 ("City"), and All City Management Services, a California Corporation with its principal place of business at 10440 Pioneer Blvd, Suite 5, Santa Fe Springs, CA, 90670 (hereinafter referred to as "Consultant"). City and Consultant are sometimes individually referred to as "Party" and collectively as "Parties" in this Agreement.

**RECITALS**

A. City is a public agency of the State of California and is in need of professional services for the following project:

Crossing Guard Services  
(hereinafter referred to as "the Project").

B. Consultant is duly licensed and has the necessary qualifications to provide such services.

C. The Parties desire by this Agreement to establish the terms for City to retain Consultant to provide the services described herein.

**AGREEMENT**

**NOW, THEREFORE, IT IS AGREED AS FOLLOWS:**

1. Services.

Consultant shall provide the City with the services described in the Scope of Services attached hereto as Exhibit "A."

2. Compensation.

a. Subject to paragraph 2(b) below, the City shall pay for such services in accordance with the Schedule of Charges set forth in Exhibit "B."

b. The total amount paid for services rendered by the Consultant under this Agreement is the sum of eight hundred ninety-seven thousand, three hundred ninety-two dollars (\$897,392). Periodic payments shall be made within 30 days of receipt of an invoice which includes a detailed description of the work performed. Payments to Consultant for work performed will be made on a monthly billing basis. In addition, during this term the Consultant may request a price increase due to any legally mandated increases in wages and benefits imposed in the state or municipality in which the services are to be performed and to which the Consultants' employees would be subject to.

3. Additional Work.

If changes in the work seem merited by Consultant or the City, and informal consultations with the other party indicate that a change is warranted, it shall be processed in the following manner: a letter outlining the changes shall be forwarded to the City by Consultant with a statement of estimated changes in fee or time schedule. An amendment to this Agreement shall be prepared by the City and executed by both Parties before performance of such services, or the City will not be required to pay for the changes in the scope of work. Such amendment shall not render ineffective or invalidate unaffected portions of this Agreement.

4. Maintenance of Records.

Books, documents, papers, accounting records, and other evidence pertaining to costs incurred shall be maintained by Consultant and made available at all reasonable times during the contract period and for four (4) years from the date of final payment under the contract for inspection by City.

5. Term

The term of this Agreement shall be from September 1, 2022, to June 30, 2025, unless earlier terminated as provided herein. The City shall solely have the option to extend the initial Term for up to three (3) successive one-year periods, which shall be deemed to be part of the Term upon exercise of such option by means of written notice to Consultant. Consultant shall perform its services in a prompt and timely manner within the term of this Agreement.

6. Delays in Performance.

a. Neither City nor Consultant shall be considered in default of this Agreement for delays in performance caused by circumstances beyond the reasonable control of the non-performing party. For purposes of this Agreement, such circumstances include but are not limited to, abnormal weather conditions; floods; earthquakes; fire; epidemics; war; riots and other civil disturbances; strikes, lockouts, work slowdowns, and other labor disturbances; sabotage or judicial restraint.

b. Should such circumstances occur, the non-performing party shall, within a reasonable time of being prevented from performing, give written notice to the other party describing the circumstances preventing continued performance and the efforts being made to resume performance of this Agreement.

7. Compliance with Law.

a. Consultant shall comply with all applicable laws, ordinances, codes and regulations of the federal, state and local government, including Cal/OSHA requirements.

b. If required, Consultant shall assist the City, as requested, in obtaining and maintaining all permits required of Consultant by federal, state and local regulatory agencies.

c. If applicable, Consultant is responsible for all costs of clean up and/ or removal of hazardous and toxic substances spilled as a result of his or her services or operations performed under this Agreement.

8. Standard of Care

Consultant's services will be performed in accordance with generally accepted professional practices and principles and in a manner consistent with the level of care and skill ordinarily exercised by members of the profession currently practicing under similar conditions.

9. Assignment and Subconsultant

Consultant shall not assign, sublet, or transfer this Agreement or any rights under or interest in this Agreement without the written consent of the City, which may be withheld for any reason. Any attempt to so assign or so transfer without such consent shall be void and without legal effect and shall constitute grounds for termination. Subcontracts, if any, shall contain a provision making them subject to all provisions stipulated in this Agreement. Nothing contained herein shall prevent Consultant from employing independent associates, and subconsultants as Consultant may deem appropriate to assist in the performance of services hereunder.

10. Independent Contractor

Consultant is retained as an independent contractor and is not an employee of City. No employee or agent of Consultant shall become an employee of City. The work to be performed shall be in accordance with the work described in this Agreement, subject to such directions and amendments from City as herein provided.

11. Insurance. Consultant shall not commence work for the City until it has provided evidence satisfactory to the City it has secured all insurance required under this section. In addition, Consultant shall not allow any subcontractor to commence work on any subcontract until it has secured all insurance required under this section.

a. Commercial General Liability

(i) The Consultant shall take out and maintain, during the performance of all work under this Agreement, in amounts not less than specified herein, Commercial General Liability Insurance, in a form and with insurance companies acceptable to the City.

(ii) Coverage for Commercial General Liability insurance shall be at least as broad as the following:

(1) Insurance Services Office Commercial General Liability coverage (Occurrence Form CG 00 01) or exact equivalent.

(iii) Commercial General Liability Insurance must include coverage for the following:

- (1) Bodily Injury and Property Damage
- (2) Personal Injury/Advertising Injury
- (3) Premises/Operations Liability
- (4) Products/Completed Operations Liability
- (5) Aggregate Limits that Apply per Project
- (6) Explosion, Collapse and Underground (UCX) exclusion deleted
- (7) Contractual Liability with respect to this Agreement
- (8) Property Damage

(9) Independent Consultants Coverage

(iv) The policy shall contain no endorsements or provisions limiting coverage for (1) contractual liability; (2) cross liability exclusion for claims or suits by one insured against another; (3) products/completed operations liability; or (4) contain any other exclusion contrary to the Agreement.

(v) The policy shall give City, its officials, officers, employees, agents and City designated volunteers additional insured status using ISO endorsement forms CG 20 10 10 01 and 20 37 10 01, or endorsements providing the exact same coverage.

(vi) The general liability program may utilize either deductibles or provide coverage excess of a self-insured retention, subject to written approval by the City, and provided that such deductibles shall not apply to the City as an additional insured.

b. Automobile Liability

(i) At all times during the performance of the work under this Agreement, the Consultant shall maintain Automobile Liability Insurance for bodily injury and property damage including coverage for owned, non-owned and hired vehicles, in a form and with insurance companies acceptable to the City.

(ii) Coverage for automobile liability insurance shall be at least as broad as Insurance Services Office Form Number CA 00 01 covering automobile liability (Coverage Symbol 1, any auto).

(iii) The policy shall give City, its officials, officers, employees, agents and City designated volunteers additional insured status.

(iv) Subject to written approval by the City, the automobile liability program may utilize deductibles, provided that such deductibles shall not apply to the City as an additional insured, but not a self-insured retention.

c. Workers' Compensation/Employer's Liability

(i) Consultant certifies that he/she is aware of the provisions of Section 3700 of the California Labor Code which requires every employer to be insured against liability for workers' compensation or to undertake self-insurance in accordance with the provisions of that code, and he/she will comply with such provisions before commencing work under this Agreement.

(ii) To the extent Consultant has employees at any time during the term of this Agreement, at all times during the performance of the work under this Agreement, the Consultant shall maintain full compensation insurance for all persons employed directly by him/her to carry out the work contemplated under this Agreement, all in accordance with the "Workers' Compensation and Insurance Act," Division IV of the Labor Code of the State of California and any acts amendatory thereof, and Employer's Liability Coverage in amounts indicated herein. Consultant shall require all subconsultants to obtain and maintain, for the period required by this Agreement, workers' compensation coverage of the same type and limits as specified in this section.

d. Minimum Policy Limits Required

(i) The following insurance limits are required for the Agreement:

Combined Single Limit

Commercial General Liability	\$1,000,000 per occurrence/ \$2,000,000 aggregate for bodily injury, personal injury, and property damage
Automobile Liability	\$1,000,000 per occurrence for bodily injury and property damage
Employer's Liability	\$1,000,000 per occurrence

(ii) Defense costs shall be payable in addition to the limits.

(iii) Requirements of specific coverage or limits contained in this section are not intended as a limitation on coverage, limits, or other requirement, or a waiver of any coverage normally provided by any insurance. Any available coverage shall be provided to the parties required to be named as Additional Insured pursuant to this Agreement.

e. Evidence Required

Prior to execution of the Agreement, the Consultant shall file with the City evidence of insurance from an insurer or insurers certifying to the coverage of all insurance required herein. Such evidence shall include original copies of the ISO CG 00 01 (or insurer's equivalent) signed by the insurer's representative and Certificate of Insurance (Acord Form 25-S or equivalent), together with required endorsements. All evidence of insurance shall be signed by a properly authorized officer, agent, or qualified representative of the insurer and shall certify the names of the insured, any additional insureds, where appropriate, the type and amount of the insurance, the location and operations to which the insurance applies, and the expiration date of such insurance.

f. Policy Provisions Required

(i) Consultant shall provide the City at least thirty (30) days prior written notice of cancellation of any policy required by this Agreement, except that the Consultant shall provide at least ten (10) days prior written notice of cancellation of any such policy due to non-payment of premium. If any of the required coverage is cancelled or expires during the term of this Agreement, the Consultant shall deliver renewal certificate(s) including the General Liability Additional Insured Endorsement to the City at least ten (10) days prior to the effective date of cancellation or expiration.

(ii) The Commercial General Liability Policy and Automobile Policy shall each contain a provision stating that Consultant's policy is primary insurance and that any insurance, self-insurance or other coverage maintained by the City or any named insureds shall not be called upon to contribute to any loss.

(iii) The retroactive date (if any) of each policy is to be no later than the effective date of this Agreement. Consultant shall maintain such coverage continuously for a

period of at least three years after the completion of the work under this Agreement. Consultant shall purchase a one (1) year extended reporting period A) if the retroactive date is advanced past the effective date of this Agreement; B) if the policy is cancelled or not renewed; or C) if the policy is replaced by another claims-made policy with a retroactive date subsequent to the effective date of this Agreement.

(iv) All required insurance coverages, except for the professional liability coverage, shall contain or be endorsed to waiver of subrogation in favor of the City, its officials, officers, employees, agents, and volunteers or shall specifically allow Consultant or others providing insurance evidence in compliance with these specifications to waive their right of recovery prior to a loss. Consultant hereby waives its own right of recovery against City, and shall require similar written express waivers and insurance clauses from each of its subconsultants.

(v) The limits set forth herein shall apply separately to each insured against whom claims are made or suits are brought, except with respect to the limits of liability. Further the limits set forth herein shall not be construed to relieve the Consultant from liability in excess of such coverage, nor shall it limit the Consultant's indemnification obligations to the City and shall not preclude the City from taking such other actions available to the City under other provisions of the Agreement or law.

g. Qualifying Insurers

(i) All policies required shall be issued by acceptable insurance companies, as determined by the City, which satisfy the following minimum requirements:

(1) Each such policy shall be from a company or companies with a current A.M. Best's rating of no less than A:VII and admitted to transact in the business of insurance in the State of California, or otherwise allowed to place insurance through surplus line brokers under applicable provisions of the California Insurance Code or any federal law.

h. Additional Insurance Provisions

(i) The foregoing requirements as to the types and limits of insurance coverage to be maintained by Consultant, and any approval of said insurance by the City, is not intended to and shall not in any manner limit or qualify the liabilities and obligations otherwise assumed by the Consultant pursuant to this Agreement, including but not limited to, the provisions concerning indemnification.

(ii) If at any time during the life of the Agreement, any policy of insurance required under this Agreement does not comply with these specifications or is canceled and not replaced, City has the right but not the duty to obtain the insurance it deems necessary and any premium paid by City will be promptly reimbursed by Consultant or City will withhold amounts sufficient to pay premium from Consultant payments. In the alternative, City may cancel this Agreement.

(iii) The City may require the Consultant to provide complete copies of all insurance policies in effect for the duration of the Project.

(iv) Neither the City nor any of its officials, officers, employees, agents or volunteers shall be personally responsible for any liability arising under or by virtue of this Agreement.

i. Subconsultant Insurance Requirements. Consultant shall not allow any subcontractors or subconsultants to commence work on any subcontract until they have provided evidence satisfactory to the City that they have secured all insurance required under this section. Policies of commercial general liability insurance provided by such subcontractors or subconsultants shall be endorsed to name the City as an additional insured using ISO form CG 20 38 04 13 or an endorsement providing the exact same coverage. If requested by Consultant, City may approve different scopes or minimum limits of insurance for particular subcontractors or subconsultants.

12. Indemnification.

a. To the fullest extent permitted by law, Consultant shall defend (with counsel of City's choosing), indemnify and hold the City, its officials, officers, employees, volunteers, and agents free and harmless from any and all claims, demands, causes of action, costs, expenses, liability, loss, damage or injury of any kind, in law or equity, to property or persons, including wrongful death, in any manner arising out of, pertaining to, or incident to any acts, errors or omissions, or willful misconduct of Consultant, its officials, officers, employees, subcontractors, consultants or agents in connection with the performance of the Consultant's services, the Project or this Agreement, including without limitation the payment of all damages, expert witness fees and attorney's fees and other related costs and expenses. Consultant's obligation to indemnify shall not be restricted to insurance proceeds, if any, received by Consultant, the City, its officials, officers, employees, agents, or volunteers.

b. To the extent required by Civil Code section 2782.8, which is fully incorporated herein, Consultant's obligations under the above indemnity shall be limited to claims that arise out of, pertain to, or relate to the negligence, recklessness, or willful misconduct of the Consultant, but shall not otherwise be reduced. If Consultant's obligations to defend, indemnify, and/or hold harmless arise out of Consultant's performance of "design professional services" (as that term is defined under Civil Code section 2782.8), then upon Consultant obtaining a final adjudication that liability under a claim is caused by the comparative active negligence or willful misconduct of the City, Consultant's obligations shall be reduced in proportion to the established comparative liability of the City and shall not exceed the Consultant's proportionate percentage of fault.

13. California Labor Code Requirements.

a. Consultant is aware of the requirements of California Labor Code Sections 1720 et seq. and 1770 et seq., which require the payment of prevailing wage rates and the performance of other requirements on certain "public works" and "maintenance" projects ("Prevailing Wage Laws"). If the services are being performed as part of an applicable "public works" or "maintenance" project, as defined by the Prevailing Wage Laws, and if the total compensation is \$15,000 or more for maintenance or \$25,000 or more for construction, alteration, demolition, installation, or repair, Consultant agrees to fully comply with such Prevailing Wage Laws. Consultant shall defend, indemnify and hold the City, its officials, officers, employees and agents free and harmless from any claims, liabilities, costs, penalties or interest arising out of any failure or alleged failure to comply with the Prevailing Wage Laws. It shall be mandatory upon the Consultant and all subconsultants to comply with all California Labor Code provisions, which

include but are not limited to prevailing wages (Labor Code Sections 1771, 1774 and 1775), employment of apprentices (Labor Code Section 1777.5), certified payroll records (Labor Code Sections 1771.4 and 1776), hours of labor (Labor Code Sections 1813 and 1815) and debarment of contractors and subcontractors (Labor Code Section 1777.1).

b. If the services are being performed as part of an applicable "public works" or "maintenance" project and if the total compensation is \$15,000 or more for maintenance or \$25,000 or more for construction, alteration, demolition, installation, or repair, then pursuant to Labor Code Sections 1725.5 and 1771.1, the Consultant and all subconsultants performing such services must be registered with the Department of Industrial Relations. Consultant shall maintain registration for the duration of the Project and require the same of any subconsultants, as applicable. This Project may also be subject to compliance monitoring and enforcement by the Department of Industrial Relations. It shall be Consultant's sole responsibility to comply with all applicable registration and labor compliance requirements.

c. This Agreement may also be subject to compliance monitoring and enforcement by the Department of Industrial Relations. It shall be Consultant's sole responsibility to comply with all applicable registration and labor compliance requirements. Any stop orders issued by the Department of Industrial Relations against Consultant or any subcontractor that affect Consultant's performance of services, including any delay, shall be Consultant's sole responsibility. Any delay arising out of or resulting from such stop orders shall be considered Consultant caused delay and shall not be compensable by the City. Consultant shall defend, indemnify and hold the City, its officials, officers, employees and agents free and harmless from any claim or liability arising out of stop orders issued by the Department of Industrial Relations against Consultant or any subcontractor.

#### 14. Verification of Employment Eligibility.

By executing this Agreement, Consultant verifies that it fully complies with all requirements and restrictions of state and federal law respecting the employment of undocumented aliens, including, but not limited to, the Immigration Reform and Control Act of 1986, as may be amended from time to time, and shall require all subconsultants and sub-subconsultants to comply with the same.

#### 15. Laws and Venue.

This Agreement shall be interpreted in accordance with the laws of the State of California. If any action is brought to interpret or enforce any term of this Agreement, the action shall be brought in a state or federal court situated in the County of Los Angeles, State of California.

#### 16. Termination or Abandonment

a. City has the right to terminate or abandon any portion or all of the work under this Agreement by giving ten (10) calendar days written notice to Consultant. In such event, City shall be immediately given title and possession to all original field notes, drawings and specifications, written reports and other documents produced or developed for that portion of the work completed and/or being abandoned. City shall pay Consultant the reasonable value of services rendered for any portion of the work completed prior to termination. If said termination occurs prior to completion of any task for the Project for which a payment request has not been received, the charge for services performed during such task shall be the reasonable value of such services, based on an amount mutually agreed to by City and Consultant of the portion of

such task completed but not paid prior to said termination. City shall not be liable for any costs other than the charges or portions thereof which are specified herein. Consultant shall not be entitled to payment for unperformed services, and shall not be entitled to damages or compensation for termination of work.

b. Consultant may terminate its obligation to provide further services under this Agreement upon thirty (30) calendar days' written notice to City only in the event of substantial failure by City to perform in accordance with the terms of this Agreement through no fault of Consultant.

17 Documents. Except as otherwise provided in "Termination or Abandonment," above, all original field notes, written reports, Drawings and Specifications and other documents, produced or developed for the Project shall, upon payment in full for the services described in this Agreement, be furnished to and become the property of the City.

18. Organization

Consultant shall assign David Mecusker as Project Manager. The Project Manager shall not be removed from the Project or reassigned without the prior written consent of the City.

19. Limitation of Agreement.

This Agreement is limited to and includes only the work included in the Project described above.

20. Notice

Any notice or instrument required to be given or delivered by this Agreement may be given or delivered by depositing the same in any United States Post Office, certified mail, return receipt requested, postage prepaid, addressed to:

CITY:

City of Arcadia

240 West Huntington Drive

Arcadia, CA 91066

Attn: John Bonomo, Administrative Sergeant

CONSULTANT:

All City Management Services

10440 Pioneer Blvd., Suite 5

Santa Fe Springs, CA 90670

Attn: David Mecusker, Marketing & Contracts  
Manager

and shall be effective upon receipt thereof.

21. Third Party Rights

Nothing in this Agreement shall be construed to give any rights or benefits to anyone other than the City and the Consultant.

22. Equal Opportunity Employment.

Consultant represents that it is an equal opportunity employer and that it shall not discriminate against any employee or applicant for employment because of race, religion, color,

national origin, ancestry, sex, age or other interests protected by the State or Federal Constitutions. Such non-discrimination shall include, but not be limited to, all activities related to initial employment, upgrading, demotion, transfer, recruitment or recruitment advertising, layoff or termination.

23. Entire Agreement

This Agreement, with its exhibits, represents the entire understanding of City and Consultant as to those matters contained herein, and supersedes and cancels any prior or contemporaneous oral or written understanding, promises or representations with respect to those matters covered hereunder. Each party acknowledges that no representations, inducements, promises or agreements have been made by any person which are not incorporated herein, and that any other agreements shall be void. This Agreement may not be modified or altered except in writing signed by both Parties hereto. This is an integrated Agreement.

24. Severability

The unenforceability, invalidity or illegality of any provision(s) of this Agreement shall not render the provisions unenforceable, invalid or illegal.

25. Successors and Assigns

This Agreement shall be binding upon and shall inure to the benefit of the successors in interest, executors, administrators and assigns of each party to this Agreement. However, Consultant shall not assign or transfer by operation of law or otherwise any or all of its rights, burdens, duties or obligations without the prior written consent of City. Any attempted assignment without such consent shall be invalid and void.

26. Non-Waiver

None of the provisions of this Agreement shall be considered waived by either party, unless such waiver is specifically specified in writing.

27. Time of Essence

Time is of the essence for each and every provision of this Agreement.

28. City's Right to Employ Other Consultants

City reserves its right to employ other consultants, including engineers, in connection with this Project or other projects.

29. Prohibited Interests

Consultant maintains and warrants that it has not employed nor retained any company or person, other than a bona fide employee working solely for Consultant, to solicit or secure this Agreement. Further, Consultant warrants that it has not paid nor has it agreed to pay any company or person, other than a bona fide employee working solely for Consultant, any fee, commission, percentage, brokerage fee, gift or other consideration contingent upon or resulting from the award or making of this Agreement. For breach or violation of this warranty, City shall have the right to rescind this Agreement without liability. For the term of this Agreement, no director, official, officer or employee of City, during the term of his or her service with City, shall

have any direct interest in this Agreement, or obtain any present or anticipated material benefit arising therefrom.

When funding for the services is provided, in whole or in part, by an agency of the federal government, Consultant shall also fully and adequately comply with the provisions included in Exhibit "D" (Federal Requirements) attached hereto and incorporated herein by reference ("Federal Requirements"). With respect to any conflict between such Federal Requirements and the terms of this Agreement and/or the provisions of state law, the more stringent requirement shall control.

**[SIGNATURES ON FOLLOWING PAGE]**

**SIGNATURE PAGE FOR PROFESSIONAL SERVICES AGREEMENT  
BETWEEN THE CITY OF ARCADIA  
AND ALL CITY MANAGEMENT SERVICES**

IN WITNESS WHEREOF, the Parties have executed this Agreement as of the date first written above.

CITY OF ARCADIA

ALL CITY MANAGEMENT SERVICES

By:   
\_\_\_\_\_  
Dominic Lazzaretto  
City Manager

By:   
\_\_\_\_\_  
Baron Farwell  
General Manager

Date: August 31, 2022

Date: 8/23/22

ATTEST:

By:   
\_\_\_\_\_  
City Clerk

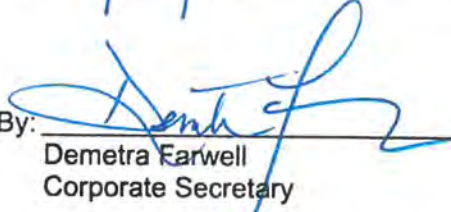
By:   
\_\_\_\_\_  
Demetra Farwell  
Corporate Secretary

APPROVED AS TO FORM

CONCUR

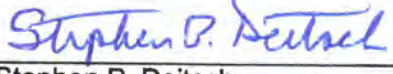
By:   
\_\_\_\_\_  
Stephen P. Deitsch  
City Attorney

By:   
\_\_\_\_\_  
Roy Nakamura  
Chief of Police

EXHIBIT A  
Scope of Services

**SCOPE OF SERVICES**

The Arcadia Police Department will utilize Consultant to provide crossing guard services at intersections near schools during the school year for an average of 10,900 hours.

There are seventeen (17) locations in the City in which crossing guards are necessary in order to provide coverage for nine (9) school sites.

**ARCADIA CROSSING GUARD SERVICE LOCATIONS**

1. Holly Avenue and Lemon Avenue
2. Camino Grove Avenue and Encino Avenue
3. 6<sup>th</sup> Avenue and Camino Grove Avenue
4. Le Roy Avenue and Santa Anita Avenue
5. 1<sup>st</sup> Avenue and Camino Real Avenue
6. 1<sup>st</sup> Avenue and Diamond Street
7. 1<sup>st</sup> Avenue and California Street
8. 2<sup>nd</sup> Avenue and Sycamore Avenue
9. Highland Oaks Drive and Sycamore Avenue
10. Oakwood Avenue and Virginia Road
11. Santa Anita Avenue and Virginia Road
12. Le Roy Avenue and Holly Avenue
13. Duarte Road and Holly Avenue
14. Woodruff Avenue and Longley Way
15. Las Tunas Drive and Warren Way
16. De Anza Place and Altura Road
17. Hugo Reid Drive and Altura Road

\*These locations are subject to change at any time.

**LIST OF SCHOOLS REQUIRING CROSSING GUARD SERVICES  
ARCADIA UNIFIED SCHOOL DISTRICT**

Baldwin Stocker Elementary School  
422 W. Lemons Avenue  
Arcadia, CA 91007

Dana Middle School  
1401 S. 1st Avenue  
Arcadia, CA 91006

Camino Grove Elementary School  
700 Camino Grove Avenue  
Arcadia, CA 91006

First Avenue Middle School  
301 S. First Avenue  
Arcadia, CA 91006

Highland Oaks Elementary School  
10 Virginia Road  
Arcadia, CA 91006

Foothills Middle School  
171 E. Sycamore Avenue  
Arcadia, CA 91006

Holly Avenue Elementary School  
360 W. Duarte Road  
Arcadia, CA 91007

Longely Way Elementary School  
2601 Longley Way  
Arcadia, CA 91007

Hugo Reid Elementary School  
Elementary Campus:  
1000 Hugo Reid Drive  
Arcadia, CA 91007  
Primary Campus:  
1153 De Anza Place  
Arcadia, CA 91007

There may be a need for summer school, which should be able to be billed as needed. In addition, in the event that crossing guard services are needed for special events, the City shall communicate extra crossing guard needs to the Consultant and the Consultant shall bill the City as necessary.

**CROSSING GUARD SCHEDULE**

	Monday	Tuesday	Wednesday	Thursday	Friday
<b>Baldwin Stocker Elementary School</b>					
<b>Holly Avenue and Lemon Avenue</b>					
AM Shift (1 hour)	7:30 AM - 8:30 AM	7:30 AM - 8:30 AM	7:30 AM - 8:30 AM	7:30 AM - 8:30 AM	7:30 AM - 8:30 AM
PM Shift (1 hour)	2:15 PM - 3:15 PM	1:00 PM - 2:00 PM	2:15 PM - 3:15 PM	2:15 PM - 3:15 PM	2:15 PM - 3:15 PM
<b>Camino Grove Elementary School</b>					
<b>Camino Grove Avenue and Encino Avenue</b>					
AM Shift (1 hour)	7:45 AM - 8:45 AM	7:45 AM - 8:45 AM	7:45 AM - 8:45 AM	7:45 AM - 8:45 AM	7:45 AM - 8:45 AM
PM Shift (1 hour)	2:20 PM - 3:15 PM	2:20 PM - 3:15 PM	1:30 PM - 2:30 PM	2:20 PM - 3:15 PM	2:20 PM - 3:15 PM
<b>Camino Grove Elementary School</b>					
<b>6th Avenue and Camino Grove Avenue</b>					
AM Shift (1 hour)	7:50 AM - 8:50 AM	7:50 AM - 8:50 AM	7:50 AM - 8:50 AM	7:50 AM - 8:50 AM	7:50 AM - 8:50 AM
PM Shift (1 hour)	2:20 PM - 3:20 PM	2:20 PM - 3:20 PM	1:30 PM - 2:30 PM	2:20 PM - 3:20 PM	2:20 PM - 3:20 PM
<b>Dana Middle School</b>					
<b>Le Roy Avenue and Santa Anita Avenue</b>					
AM Shift (1 hour)	7:30 AM - 8:30 AM	7:30 AM - 8:30 AM	7:30 AM - 8:30 AM	7:30 AM - 8:30 AM	7:30 AM - 8:30 AM
PM Shift (1 hour)	2:45 PM - 3:45 PM	2:45 PM - 3:45 PM	1:45 PM - 2:45 PM	2:45 PM - 3:45 PM	2:45 PM - 3:45 PM
<b>Dana Middle School</b>					
<b>1st Avenue and Camino Real Avenue</b>					
AM Shift (1 hour)	7:30 AM - 8:30 AM	7:30 AM - 8:30 AM	7:30 AM - 8:30 AM	7:30 AM - 8:30 AM	7:30 AM - 8:30 AM
PM Shift (1 hour)	2:45 PM - 3:45 PM	2:45 PM - 3:45 PM	1:45 PM - 2:45 PM	2:45 PM - 3:45 PM	2:45 PM - 3:45 PM
<b>First Avenue Middle School</b>					
<b>1st Avenue and Diamond Street</b>					
AM Shift (1 hour)	7:30 AM - 8:30 AM	7:30 AM - 8:30 AM	7:30 AM - 8:30 AM	7:30 AM - 8:30 AM	7:30 AM - 8:30 AM
PM Shift (1 hour)	3:00 PM - 3:45 PM	2:00 PM - 2:45 PM	3:00 PM - 3:45 PM	2:00 PM - 2:45 PM	3:00 PM - 3:45 PM

<b>First Avenue Middle School</b>	<b>1<sup>st</sup> Avenue and California Street</b>	AM Shift (1 hour) 7:30 AM - 8:30 AM PM Shift (1 hour) 3:00 PM - 3:45 PM	7:30 AM - 8:30 AM 2:00 PM - 2:45 PM	7:30 AM - 8:30 AM 3:00 PM - 3:45 PM	7:30 AM - 8:30 AM 2:00 PM - 2:45 PM	7:30 AM - 8:30 AM 3:00 PM - 3:45 PM
<b>Foothills Middle School</b>	<b>2<sup>nd</sup> Avenue and Sycamore Avenue</b>	AM Shift (1 hour) 7:40 AM - 8:40 AM PM Shift (1 hour) 2:25 PM - 3:25 PM	7:40 AM - 8:40 AM 2:25 PM - 3:25 PM	7:40 AM - 8:40 AM 2:25 PM - 3:25 PM	7:40 AM - 8:40 AM 2:25 PM - 3:25 PM	7:40 AM - 8:40 AM 2:25 PM - 3:25 PM
<b>Foothills Middle School</b>	<b>Highland Oaks Drive and Sycamore Avenue</b>	AM Shift (1 hour) 7:40 AM - 8:40 AM PM Shift (1 hour) 2:25 PM - 3:25 PM	7:40 AM - 8:40 AM 2:25 PM - 3:25 PM	7:40 AM - 8:40 AM 2:25 PM - 3:25 PM	7:40 AM - 8:40 AM 2:25 PM - 3:25 PM	7:40 AM - 8:40 AM 2:25 PM - 3:25 PM
<b>Highland Oaks Elementary School</b>	<b>Oakwood Avenue and Virginia Road</b>	AM Shift (1 hour) 7:40 AM - 8:40 AM PM Shift (1 hour) 2:25 PM - 3:25 PM	7:40 AM - 8:40 AM 2:25 PM - 3:25 PM	7:40 AM - 8:40 AM 2:25 PM - 3:25 PM	7:40 AM - 8:40 AM 2:25 PM - 3:25 PM	7:40 AM - 8:40 AM 2:25 PM - 3:25 PM
<b>Highland Oaks Elementary School</b>	<b>Santa Anita Avenue and Virginia Road</b>	AM Shift (1 hour) 7:45 AM - 8:45 AM PM Shift (1 hour) 2:15 PM - 3:25 PM	7:45 AM - 8:45 AM 2:15 PM - 3:25 PM	7:45 AM - 8:45 AM 1:10 PM - 2:10 PM	7:45 AM - 8:45 AM 2:15 PM - 3:25 PM	7:45 AM - 8:45 AM 2:15 PM - 3:25 PM
<b>Holly Avenue Elementary School</b>	<b>Le Roy Avenue and Holly Avenue</b>	AM Shift (1 hour) 7:45 AM - 8:45 AM PM Shift (1 hour) 2:15 PM - 3:15 PM	7:45 AM - 8:45 AM 2:15 PM - 3:15 PM	7:45 AM - 8:45 AM 1:10 PM - 2:10 PM	7:45 AM - 8:45 AM 2:15 PM - 3:15 PM	7:45 AM - 8:45 AM 2:15 PM - 3:15 PM
		AM Shift (1 hour) 7:30 AM - 8:30 AM PM Shift (1 hour) 2:15 PM - 3:15 PM	7:30 AM - 8:30 AM 1:00 PM - 2:00 PM	7:30 AM - 8:30 AM 2:15 PM - 3:15 PM	7:30 AM - 8:30 AM 2:15 PM - 3:15 PM	7:30 AM - 8:30 AM 2:15 PM - 3:15 PM

Holly Avenue Elementary School	Duarte Road and Holly Avenue	AM Shift (1 hour)	7:30 AM - 8:30 AM	7:30 AM - 8:30 AM	7:30 AM - 8:30 AM	7:30 AM - 8:30 AM
		PM Shift (1 hour)	2:15 PM - 3:15 PM	2:15 PM - 3:15 PM	2:15 PM - 3:15 PM	2:15 PM - 3:15 PM
Longley Way Elementary School	Woodruff Avenue and Longley Way	AM Shift (1 hour)	7:45 AM - 8:45 AM	7:45 AM - 8:45 AM	7:45 AM - 8:45 AM	7:45 AM - 8:45 AM
		PM Shift (1 hour)	2:30 PM - 3:30 PM	2:30 PM - 3:30 PM	2:30 PM - 3:30 PM	2:30 PM - 3:30 PM
Longley Way Elementary School	Las Tunas Drive and Warren Way	AM Shift (1 hour)	7:45 AM - 8:45 AM	7:45 AM - 8:45 AM	7:45 AM - 8:45 AM	7:45 AM - 8:45 AM
		PM Shift (1 hour)	2:30 PM - 3:30 PM	2:30 PM - 3:30 PM	2:30 PM - 3:30 PM	2:30 PM - 3:30 PM
Hugo Reid Elementary School	De Anza Place and Altura Road	AM Shift (1 hour)	7:45 AM - 8:45 AM	7:45 AM - 8:45 AM	7:45 AM - 8:45 AM	7:45 AM - 8:45 AM
		PM Shift (1 hour)	2:30 PM - 3:30 PM	2:30 PM - 3:30 PM	2:30 PM - 3:30 PM	2:30 PM - 3:30 PM
Hugo Reid Elementary School	Hugo Reid Drive and Altura Road	AM Shift (1 hour)	7:35 AM - 8:35 AM	7:35 AM - 8:35 AM	7:35 AM - 8:35 AM	7:35 AM - 8:35 AM
		PM Shift (1 hour)	2:20 PM - 3:20 PM	2:20 PM - 3:20 PM	2:20 PM - 3:20 PM	2:20 PM - 3:20 PM
Hugo Reid Elementary School	Hugo Reid Drive and Altura Road	AM Shift (1 hour)	7:35 AM - 8:35 AM	7:35 AM - 8:35 AM	7:35 AM - 8:35 AM	7:35 AM - 8:35 AM
		PM Shift (1 hour)	2:20 PM - 3:20 PM	2:20 PM - 3:20 PM	2:20 PM - 3:20 PM	2:20 PM - 3:20 PM

**Normal Early Release Days**

### *Minimum Service Requirements*

Consultant must at a minimum provide the following services and benefits:

- A. Provide a program manager who will coordinate crossing guard services with a Police Department liaison.
- B. Provide a supervisor to ensure guard activities are taking place at the required places and times and that proper safety procedures are complied with.
- C. Provide fully trained and equipped alternate personnel to ensure all contracted locations are covered in the event regular personnel are absent.
- D. Provide all crossing guards with a standardized uniform and proper weather apparel and gear, approved by the Chief of Police, which will be worn at all times while performing their duties.
- E. Provide all crossing guards with handheld stop signs and reflective vests, which comply with applicable Federal, State and City laws and regulations.
- F. Persons provided by the contractor as crossing guards shall be trained by the contractor.

Training shall include the laws and codes of the State of California and the City of Arcadia pertaining to general pedestrian safety and school crossing areas. Training shall also include general traffic safety for pedestrians, motorists, and the crossing guards themselves. Copies of all training certificates must be provided prior to execution of the contract. Provide training for crossing guards in first aid and CPR in accordance with Red Cross certification guideline. Copies of valid Red Cross certificates on each crossing guard must be furnished to the Police Department prior to signing of the agreement and annually thereafter.

- G. Provide evidence of compliance with California Vehicle Code section 21100 as it relates to crossing guards and compliance with California Vehicle Code section 21100(i) prior to execution of the Agreement.

### **Contractor Personnel Requirements**

Consultant shall maintain personnel files. Files shall consist of a package of documents for each assigned Crossing Guard consisting of training records, minimum qualifications and includes medical record, social security number, military services, arrest records, and previous employment. Contractor shall provide the Police Chief or his designee with written certification that each Guard assigned to the City conforms to all Police Department's requirements and standards specified in this Agreement.

## **Criminal Background Check**

The Contractor shall complete a criminal background check of all Crossing Guards, prior to assignment under the contract, and prior to assigning a Crossing Guard to a City location. Thereafter, Contractor shall conduct an annual check, or as deemed necessary for security reasons. The criminal background check shall be for felony for violent crimes and felony related to any acts against children, misdemeanor and traffic violations in all United States or countries that the individual has resided in the last five (5) years.

Any Crossing Guard found failing to divulge a felony (as listed below) or misdemeanor conviction should not be assigned to the Police Department's contract. All costs of these checks shall be at the Contractor's expense.

- 1) Crossing Guards who have been involved in any of the following will not be accepted nor assigned to City Crossing Guard service:
  - a) Felony Conviction related to the following: violent crimes, any acts against children, assault, sexual assault, and domestic violence.
  - b) Violent Misdemeanor Conviction
  - c) Sex Crime Conviction
  - d) Military discharge other than honorable
  - e) Pattern of irresponsible behavior including, but not limited to, unreasonable driving or employment record (absenteeism, equipment abuse, disciplinary problems, insubordination)
  
- 2) Verification for above violations, military conduct, and crime will be done through California Department of Justice, DMV, and/or FBI

## **Crossing Guard Conduct**

Consultant's Crossing Guards will be working at City locations, and as such, they must be polite, courteous, helpful, and interested in serving the public well. Professional standards are expected at all times while on a City post. The Police Chief's designated representative will routinely conduct surprise inspections to ensure the quality of contract Crossing Guards assigned to the City. If it is determined that assigned Crossing Guards do not meet standards of courtesy, ethics, appearance, alertness, and preparedness, they will be removed from post immediately at the expense of the Consultant.

## **Consultant Supervision Requirements**

### *Operations Manager*

The Consultant will assign an Operations Manager to ensure the required field supervision and training to the Crossing Guards under his/her supervision during the performance of their duties as required by the contract. The Operations Manager need not be present at all times but should ensure that Crossing Guards assigned to the City are well trained and effective in carrying out their assigned duties. This person will be the liaison to the Police Department. The Operations Manager shall become the Police Department's primary contact person and be available as needed for the administration and effective functioning of the requested crossing guard services required in the Contract. Police Department staff will have direct access to a manager or shift supervisor. Contract crossing guard company will provide phone numbers to Police Department staff.

### **CITY SUPERVISION**

The City's Chief of Police, or his designee, shall have the right of general supervision of all work performed by vendor and shall be the City's agent with respect to obtaining vendor's compliance hereunder. No payment for any services rendered under the agreement shall be made without prior approval of the Chief of Police, or his designee.

EXHIBIT B

Schedule of Charges/Payments

City shall compensate All City Management Services for crossing guard services provided hereunder as follows:

<b>Position Classification</b>	<b>Hourly Billing Rate</b>	<b>Annual Cost</b>
Crossing Guard Year 1 (September 1, 2022 – June 30, 2023)	\$27.07	\$289,920.00
Crossing Guard Year 2 (July 1, 2023 – June 30, 2024)	\$28.36	\$303,736.00
Crossing Guard Year 2 (July 1, 2024 – June 30, 2025)	\$28.36	\$303,736.00
<b>Total</b>		<b>\$897,392.00</b>

The total cost for Year 1 shall not exceed \$289,920.  
The total cost for Year 2 shall exceed \$303,736.  
The total cost for Year 3 shall not exceed \$303,736.

The total cost for the initial three-year period of the contract, from September 1, 2022, through June 30, 2025, shall not exceed \$897,392.

During the term of the Agreement the Consultant may request a price increase due to any legally mandated increases in wages and benefits imposed in the state or municipality in which services are to be performed and to which the Consultant's employees would be subject to.

The hourly rates listed are fully loaded rates, meaning all of the costs are included in the "hourly billing rate". This includes but not limited to: recruitment, background clearance, training, equipment, insurance, supervision and management of the City of Arcadia's Crossing Guard Program.

The pricing for Year 1 is based on 17 crossing guards compensated per the current Arcadia schedule of 180 school days annually. Local field supervision and substitute guards are also included in the rate, as are all other costs except as noted below.

The hourly rate does not include additional safety equipment, crosswalk delineators, cones or safety devices. If the City should desire any such additional equipment, the additional cost will be billed to the City.

If the City requires extra crossing guard services for special events, the City will be billed for such services requested.

Other provisions:

Consultant will mail invoices for services every two weeks. Included with each invoice will be a Work Summary, which details each site, each day and the hours worked at that site. Arcadia will only be billed for crossing guard services rendered on designated "school days" unless otherwise requested by the City.

## EXHIBIT C

### Activity Schedule

Consultant shall provide crossing guard services for seventeen (17) locations covering nine (9) school sites in the City of Arcadia. The number of hours worked is based on the Arcadia Unified School District school schedule of 180 school days annually, which equates to approximately 10,900 billable hours.

The Consultant and the City shall communicate via electronic mail regarding any crossing guard schedule changes, such as a change in crossing guard hours or posts.



**AMENDMENT NO. 5 TO PROFESSIONAL SERVICES AGREEMENT WITH ALL CITY  
MANAGEMENT SERVICES FOR CROSSING GUARD SERVICES**

This Amendment No. 5 is hereby entered into by and between the City of Arcadia, a charter city organized under the Constitution and laws of the State of California, and All City Management Services, a California Corporation, with respect to that certain Professional Services Agreement between the parties dated August 31, 2022 ("Agreement").

The parties agree as follows:

1. Section 2. (b) Compensation and Exhibit "B" of the Agreement is amended to increase the cost of Fiscal Year 2026-27, beginning July 1, 2026, to June 30, 2027, to three hundred ninety-four thousand, six hundred fifty-seven dollars and no cents (\$394,657 rounded) per the attached Client Worksheet for 2026-2027.
2. Section 5. Term is hereby extended to July 1, 2026, to June 30, 2027.
3. All the remaining terms and provisions of the Agreement are hereby reaffirmed.

In witness whereof the parties have executed this Amendment No. on the date set forth below.

**[SIGNATURES ON FOLLOWING PAGE]**

**CITY OF ARCADIA**

**ALL CITY MANAGEMENT SERVICES**

\_\_\_\_\_  
Dominic Lazzaretto  
City Manager

\_\_\_\_\_  
Baren Farwell  
General Manager

Date: \_\_\_\_\_

Date: \_\_\_\_\_

ATTEST:

\_\_\_\_\_  
City Clerk

\_\_\_\_\_  
Demetra Farwell  
Corporation Secretary

Date: \_\_\_\_\_

APPROVED AS TO FORM:

CONCUR:

\_\_\_\_\_  
Michael J. Maurer  
City Attorney

\_\_\_\_\_  
Roy Nakamura  
Chief of Police

**All City Management Services Inc.**

**Client Worksheet 2026-2027**

**Department:** 1007801

**Billing Rate for 2026-2027:** \$ 32.43

City of Arcadia  
250 W. Huntington Drive  
Arcadia, CA 91007

**KEY:**

**Traditional Calendar:**

For sites with no regularly scheduled early release days, use 180 regular days

**Sites with traditional calendar:**

	<input type="text" value="66.5"/>		<input type="text" value="183"/>		<input type="text" value="\$32.43"/>	=	<input type="text" value="\$394,656.89"/>
19 Sites at 3.50 hrs per day	Total Hrs/day	X	days/yr	X	Hourly Billing Rate		

**TOTAL PROJECTED HOURS**                      **12,169.50**                      **TOTAL ANNUAL PROJECTED COST**                      **\$394,656.89**

**DATE:** June 16, 2026

**TO:** Honorable Mayor and City Council

**FROM:** Lisa Flores, Development Services Director  
By: Simon Vuong, Economic Development Manager

**SUBJECT:** AGREEMENT FOR SERVICES WITH THE ARCADIA CHAMBER OF  
COMMERCE FOR FISCAL YEAR 2026-27 IN THE AMOUNT OF \$104,367  
**CEQA: Not a Project**  
**Recommendation: Approve**

### **SUMMARY**

The Arcadia Chamber of Commerce (the “Chamber”) provides programming and activities that benefit its members and the entire business community. The City of Arcadia and the Chamber execute an annual Agreement for Services (“Agreement”) for small business support and marketing. As proposed in the Agreement for Fiscal Year 2026-27, the City will provide the Chamber with \$104,367 for its efforts on behalf of the business community, and to complement the City’s marketing activities.

It is recommended that the City Council approve, authorize, and direct the City Manager to execute the Agreement for Services with the Arcadia Chamber of Commerce for Fiscal Year 2026-27, in the amount of \$104,367.

### **BACKGROUND**

The Chamber and the City have long cooperated on issues and projects of mutual interest to the Arcadia civic and business community. As part of this cooperation, the City enters into an annual Agreement for Services with the Chamber to provide public relations, business development, and governmental/legislative services in support of the Arcadia business community and general economic development. The Chamber Summary Report, included as Attachment No. 1, highlights some of the events, programs, and activities from the 2025-26 Fiscal Year. The Chamber Annual Financial

Summary, included as Attachment No. 2, provides additional details on Chamber funding sources, expenditures, and finances.

In addition to the annual Agreement for Services, the Chamber also utilizes the City-owned property at 388 West Huntington Drive for its offices, at a discounted rate. The current lease rate of \$400 per month with the Chamber, which was approved in December 2021 and extends through November 2026, is well below the current at-market rate, estimated to be \$3,800 per month for a 1,900 square-foot office in central Arcadia.

## **DISCUSSION**

The Chamber of Commerce offers a variety of important services to the business community in Arcadia, including:

- Providing reference information and referral services about the City to brokers, realtors, merchants, business operators, and interested public.
- Communicating frequently via e-mail with monthly event calendars, weekly event reminders, and regular website updates.
- Utilizing social media, including Facebook, X, and Instagram, to expand outreach for events, including mixers, business breakfasts, and ribbon cuttings.
- Hosting, promoting, and managing the Taste of Arcadia event along with several other annual or biennial events, such as job fairs and other workforce and economic development initiatives.
- Organizing and providing staff support for regularly scheduled meetings, such as the Community Connection meeting, Chamber Ambassador meetings, Business Networking Breakfasts (Rise and Shine Arcadia), business mixers, Arcadia Business Community (“ABC”) Groups, etc.
- Working with and supporting the Downtown Arcadia Improvement Association (“DAIA”), including various planning activities and events held in the Downtown.

- Conducting business visits to learn about the different businesses in Arcadia, providing business owners with contact information and services available through the City and the Chamber.
- Coordinating with the City on retail recruitment, targeted economic development opportunities, and marketing efforts.

The proposed Agreement for Services with the Chamber for Fiscal Year 2026-27 is included as Attachment No. 3. The Agreement provides for annual financial support from the City and includes an exhibit that further details the Chamber's services benefitting the City and the business community. The proposed Agreement includes an increase of 3.2% based on the U.S. Department of Labor Consumer Price Index increase for the Los Angeles-Long Beach-Anaheim region, over the 2025 calendar year. This amounts to an additional \$3,236 in funding compared to the previous Fiscal Year allocation, totaling \$104,367 for Fiscal Year 2026-27. The funding provided by the City is anticipated to account for approximately 20% of the Chamber's overall income for Fiscal Year 2026-27, with the remainder provided by membership dues, sponsorships, and event proceeds.

### **ENVIRONMENTAL ANALYSIS**

The proposed action does not constitute a project under the California Environmental Quality Act ("CEQA") under Section 15061(b)(3) of the CEQA Guidelines, as it can be seen with certainty that it will have no impact on the environment.

### **FISCAL IMPACT**

Since 2015, the annual Agreement for Services with the Chamber has been adjusted based on the Consumer Price Index ("CPI"). CPI growth has moderated in recent years, declining from 7.4% in 2022 to 3.5% in 2023, and 3.2% in 2025. The City will continue to utilize CPI adjustments to help ensure equitable and appropriate funding for the Chamber's services in the future.

For Fiscal Year 2025-26, the City allocated \$101,200 for Chamber services. The proposed Fiscal Year 2026-27 General Fund Budget includes \$106,100 for the

Chamber of Commerce. The annual Agreement for Services totals \$104,367; therefore, sufficient funding is available within the proposed budget to execute the Agreement.

**RECOMMENDATION**

It is recommended that the City Council determine that this Agreement does not constitute a project under the California Environmental Quality Act ("CEQA"); and approve, authorize, and direct the City Manager to execute an Agreement for Services with the Arcadia Chamber of Commerce for Fiscal Year 2026-27 in the amount of \$104,367.

Approved:

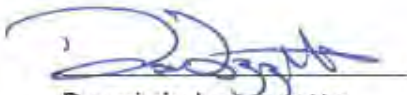

Dominic Lazzaretto  
City Manager

- Attachment No. 1: Chamber Summary Report for Fiscal Year 2025-26
- Attachment No. 2: Chamber Annual Financial Summary for Fiscal Year 2025-26
- Attachment No. 3: Agreement for Services for Fiscal Year 2026-27

# Attachment No. 1

Chamber Summary Report for Fiscal Year  
2025-26



## Mission Statement

To play a critical and integral role in maintaining a healthy business environment, contributing to the economic growth of the members, the city, and enhancing the city's image.

### January 2026

to

### June 2026



# Public Relations

## Community Focus

The first six months of 2026 saw the Arcadia Chamber focusing heavily on building on new membership and retaining current members, all while highlighting our ever-popular networking events. Economic hardship continues to strain many businesses, but with the addition of newer low-cost events like Happy Hour Hop, Morning Brew, and Lunch Link-Up, members have found ways to engage with other members without having to spend as much out of their own pockets. These events only require guests to pay for what they eat or drink, which can help keep their costs low.



Another focus for early 2026 has been expanding on board and ambassador participation, along with creating new ways to promote marketing benefits that come along with general membership. A membership drive in March brought in a record number of new members, with the board bringing in 27 of the 48 total new members.

The Arcadia Chamber also put great focus on our April 30<sup>th</sup> golf tournament, bringing in new sponsors like Surfside Vodka, and moving to create an event unlike any other in the San Gabriel Valley. The popularity of the Arcadia Chamber Golf Classic, the 4<sup>th</sup> on record, led to foursomes and hole heroes selling out weeks prior to the event.

While some businesses and chambers are still feeling the impact of the 2025 Eaton Canyon Fire, the Arcadia Chamber has continued to embrace opportunities to showcase our value to our community at large, providing high-class networking, more marketing opportunities than ever, and customer service from Chamber staff that is top-notch.



# #ArcadiaStrong-er



The Arcadia Stronger program continues to assist businesses throughout the City of Arcadia by providing Chamber membership to those who might be struggling. Some of these businesses are still feeling the effects of the Eaton Canyon Fire, while others facing economic hardship cannot consider Chamber membership in their overall budgets. The program is coming to an end, with only a few additional memberships to give away.

## Arcadia Stronger Member Breakdown



Total Members  
**460**

New Members - January thru June  
**81**

Arcadia Stronger Members  
January thru June  
**7**

Additional Paid New Members  
January thru June  
**74**

Arcadia Stronger members in recent months include businesses like Fika Fika Coffee, recommended to the Chamber from Long Toyota, A&T Pro Agency, and Coast 2 Coast Roasters.

Currently 7 businesses have joined under this program in 2026, with 159 total members having come through the program since 2023.



## Social Media

The Arcadia Chamber utilizes social media in the form of Instagram, Facebook, WeChat, LinkedIn, and X (Twitter) to help promote and pass along information from the Chamber and its members. The Chamber's Facebook page has over 3,300 followers, and Instagram has surpassed Facebook with almost 3,500 followers. LinkedIn has 310 followers to date.



Another platform used by the Arcadia Chamber is Constant Contact, which has almost 6,000 active community email subscribers. Monthly email blasts and paid e-blasts from members go out to all email addresses, to keep the community up to date on happenings with the Arcadia Chamber and its membership base. Each month, the calendar of events is sent to all subscribers, along with a new member corner article written by current Chamber president, Christine Zito.



The Arcadia Chamber Members-Only Facebook group was created to give members a way to post more often to their targeted audience: other Chamber members. Currently, this group has 140 members, many of whom are active and post regularly.

## Committees

Committees currently include the Board and Ambassador teams, along with the Membership, and Events committees, plus a

group focusing on the Golf Tournament. These groups meet approximately once per month to discuss their topics and make changes and suggestions to help build membership and improve the Chamber overall.



The **Ambassador Team** continues to invite new members to their monthly meetings, which have good attendance overall. With the larger numbers of new members, Ambassador meetings continuously have 7 to 10 new members each time, with the largest meeting having 12 new members in attendance.

At the Ambassador meeting, held in the Arcadia Chamber conference room, new members meet their personal ambassador, Arcadia Chamber staff, and other Ambassadors. This gives new members a more personal introduction to the Chamber itself. The



2026 team is led by the Arcadia Chamber's Director of Sales, Jose Luis Correa.

The **Membership Committee** works on new member sales and ideas to market to new members. The committee has been coming up with new and innovative ideas to help build the Arcadia Chamber membership base.

The **Golf and Events Committee** planned the 2026 event on April 30<sup>th</sup> at Brookside Golf Course, which was a great success.

The **Policy and By-Law Committee** completed the by-laws and at the February Strategic Planning Meeting, the board voted to adopt the adjusted by-laws.

## *Membership*

Along with events, the Arcadia Chamber has been focused heavily on membership; not just new members, but also in retaining current members. While bringing in new members is very important to the Arcadia Chamber overall, staff also felt current members needed a touch-base system, in which staff and ambassadors both reach out consistently, invite members, and make them aware of marketing opportunities and special events.



To assist in retention, the Arcadia Chamber continues its three-point (90 day) system of touch-bases for members upon their renewal, starting with an emailed invoice from our bookkeeper. Then a physical invoice is sent via mail, with selected members emailed again, by Carrie. Then Jose Luis makes a personal visit to the place of business to hand deliver the invoice. The system works well, especially in the area of members who are not as tech savvy and might not receive initial emails.

Jose Luis consistently makes rounds of the local community, stopping in at members' locations, and visiting new and established businesses who are not yet members. This personal connection brings in many new members, who report one of the main reasons for joining were those in-person visits. Jose Luis also continues to visit networking events all over the San Gabriel Valley, to engage with businesses and professionals, sharing information on the Arcadia Chamber and inviting folks to try out our events.



The Chamber's 110% Club program is in full swing, with 297 members taking advantage of the program, from January through June. Flyers and information are continuously posted and updated on a wall in the Chamber office to showcase events, promotions, and specials from those members.

Retention for returning members is at 62%, 3 points above our last reporting.



## Member Events

### *ABC (Arcadia Business Community) Groups*

The Arcadia Chamber ABC Groups, small networking groups, of no more than 20 members, meet at different times of the month and time of day, at Chamber member locations all over the San Gabriel Valley. ABC Groups continue to thrive, attracting new and experienced members. Some members even attend multiple groups throughout the month!

These 2026 leaders included Heidi Bloks of Berkshire Hathaway Golden Properties (who took over leadership of Christine Zito's group), Dana Borelli of CA Flat Fee and Jennifer Kerzie from the Derby, who host their group at Don Ricardo's. Mitch Woolley of E-Marketing Associates, James Doyle of Doyle Accident Attorneys, and Jesus Pimentel of Oncore Solar and James Alewine III of Modern Woodmen of America all host their various groups in the Arcadia Chamber Conference Room.

Topics include perfecting AI for your business, generating leads, and using the Arcadia Chamber membership perks, while others have speakers on multiple business-related topics.

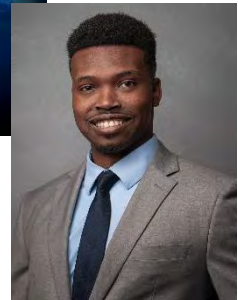

## *Rise & Shine Arcadia – 3<sup>rd</sup> Thursday each Month*



At Rise & Shine, guests can network, give 30 second elevator pitches, play games, and get to know each other during networking, all to help grow their business and drum up new clientele.

Rise & Shine continues to grow and thrive, with attendance now averaging 50 to 60+ guests consistently each month. Rise & Shine venue hosts in the first six months of 2026 have included Embassy Suites, Santa Anita Park, the DoubleTree Hotel, Marko's in Duarte, and the brand-new Hilton Arcadia, who hosted our first Rise & Shine of year in January.



Rise & Shine continues to be sponsored by Pure Media Marketing, with Diane Pierson of Always Best Care as our Coffee & Toast sponsor for 2026. CA Flat Fee returned as the Entertainment sponsor also for 2026. DJ John Villa of Dance Syndicate also continues as entertainment for Rise & Shine.

The Arcadia Chamber's Business Spotlight Booths, wherein a member can host a booth for only \$100 at Rise & Shine to sell products and promote their business during the event, has been a popular addition to this event. Business Spotlight Members have included David Lamb Woodworx, who sells custom made woodworked products, like charcuterie boards and butcher blocks, along with farmhouse furniture.

A new addition to Rise & Shine in late 2025 was Non-Profit Spotlight booths, highlighting some of the chamber's great non-profit organizations. Non-profit organizations very much enjoy this opportunity, and some participants in early 2026 include Habitat for Humanity, Foothill Unity Center, the Boys & Girls Club of the Foothills, and the Arcadia Historical Society.



## Connect & Prosper – 4<sup>th</sup> Wednesday every other Month

Connect & Prosper events occur every other month, hosted by New Fusion and the brand-new XiBei Restaurant (in the Shops at Santa Anita). This event’s focus is to assist the Mandarin-speaking community and provide networking opportunities to that group.



Led by Board Member and Past-President Francine Chiu of Star Seven Financial Services, Connect & Prosper has helped bridge the gap in the business community with Mandarin-speaking members.

Members regularly in attendance include a representative from the EverTrust Bank, DoubleTree Hotel, Always Best Care, Mutual Escrow, USC Arcadia Hospital, and more. Star Seven

Financial Services is our sponsor for 2026. Forest Lawn continues to be a Red Envelope sponsor, as well.



## Mixers

The Arcadia Chamber has put a very big focus on mixers in 2026, with the goal of hosting one MIX event per month at a different location, starting in February. The Kensington Sierra Madre hosted the first event of the year, a Valentine’s Day themed event on one of their outdoor patios. Fogo de Chao was our host for March, and the Habitat for Humanity ReStore in Pasadena hosted April, and new member, the Mattress Store of Pasadena, will be our host in June.



Mixer attendance can range from 30 to 40 guests to upwards of 100+ and beyond, as occurred with the Arcadia Chamber’s very popular Multi-Chamber Mixer event at the Le Meridien Hotel, held on May 20<sup>th</sup>. The Le Meridien has hosted this event for multiple years running, bringing together 16+ local Chambers from the San Gabriel Valley and beyond.

The Multi-Chamber mix at the Le Meridien hosted 275 guests, plus 18 Business Spotlight Booths, including a headshot booth, plus food and drinks from the Le Meridien, and a fun photo booth from Chamber member, Glamify Me. DJ John Villa provided entertainment, as well.



# Arcadia Chamber Networking@Noon

## Networking at Noon

Networking at Noon is one of the Arcadia Chamber's fastest growing events. Held on the 4<sup>th</sup> Thursday of each month at the world famous Derby, guests at Networking at Noon play networking games, give their 30 seconds pitches, and give and receive raffle prizes, all while building their business.



Networking at Noon generally gathers 45 to 55 guests, and this event continues to gain the attention of new and prospective members. The Derby will continue to be our main Networking at Noon host throughout 2026 until the holiday months, when other members will have an opportunity to host.

## Ribbon Cuttings

Members frequently contact the Chamber for ribbon cuttings to celebrate a grand opening, specific event, or milestone for that member.



Lots of new members celebrated their grand openings, like the new Hilton Arcadia, Mission Valley Bank, and Arcadia Preschool Academy. Others celebrated various milestones, such as Rally Point Barber Shop, who celebrated their 1-year anniversary, the same with Willie's Vintage, and The Money Store, who celebrated moving into their new

location. The Arcadia Chamber partnered with the Monrovia Chamber in conducting the Mission Valley Bank and Money Store events.



# Community Connection -1<sup>st</sup> Thursday of Each Month



Community Connection continues to help engage the community and boost participation in a virtual setting, which in turn has helped boost overall attendance at this important event. Information was provided by the Arcadia Community Center on upcoming summer activities, from Simon Vuong from the City of Arcadia’s Economic Development Department, and from Supervisor Kathryn Barger, who reported on recovery from the Eaton Canyon Fire and additional legislation pertaining to local businesses.

Legislative Reps regularly attend this meeting to provide up-to-date information on new legislature, laws and regulations, and happenings throughout our county and state.



Community Connection is recorded and put out on social media, for future viewing, so watchers can keep up with City happenings, updates from local entities, plus news from our legislative reps.

**Smart 401(k) Strategies for Employers**

Build on CDavers or unsure about your current 401(k)? Come to the Arcadia Chamber Learning Lab to review your options and/or benchmark your existing plan for potential savings.

Learn how the Arcadia Chamber Pooled 401(k) turns complex plan management into a simpler, cost-effective solution, reducing administrative burden and liability.

FREE to Members/\$15 to Non-Members

**January 14 - 12pm to 1pm**

Arcadia Chamber Conference Room  
388 W. Huntington Dr., Arcadia

Modern Woodmen  
TRADITIONAL FINANCIAL

Presenter:  
**James Alewine III**  
Topic: Smart 401(k) Strategies for Employers

Thank You to our Sponsor

## Learning Lab

Learning Labs have proven to be very popular events, and the Arcadia Chamber has been increasing the number of events. Speakers in the first six months of 2026 have included James Alewine III of Modern Woodmen of American, discussing 401ks for employers, Vic Kerasimian of Aire Serv, talking about the importance of clean air for home and businesses, and

Cameron Rogers of Paychex, giving information on payroll, HR, and general compliance.



Tools To Take Your Business To The Next Level



## Arcadia Classic Golf Tournament



The Arcadia Chamber held its 4<sup>th</sup> annual Golf Classic on April 30<sup>th</sup> at Brookside Golf Course, which was sold out for both golfer foursomes and hole hero booths earlier than any prior year.

144 golfers, including local business owners, residents, plus staff from Santa Anita Park, Foothill Credit Union, Post Alarm, and the City of Arcadia, played the course and visited 18 hole hero booths to play games, win prizes, and get fun swag. Longo Toyota hosted the hole-in-one (no winner this year), and Surfside Vodka provided drinks on the course. Additional hole heroes included the Le Meridien Hotel, Foothill Credit Union, Rose Hills, Mohajer Law, David Lamb Woodworx, Gameday Men's Health, the Hilton Arcadia, Servpro, New York Life, Garvey Roofing, Anytime Fitness, Farmers Insurance, BMO, Modern Woodmen, and Post Alarm. Rivian and Thorson Motors both showcased a car on the course, as well.

Golfers also were able to purchase raffle tickets for prizes donated by many of our Chamber members, along with 50/50 raffle tickets. The 50/50 winner took home over \$2000 this year! The Arcadia Chamber Golf Classic is one of our most popular fundraisers, and we are working with Brookside Golf Course to book the date for 2027.



## Business Development

The Chamber continued its mission to assist businesses and help the community grow in the City of Arcadia.

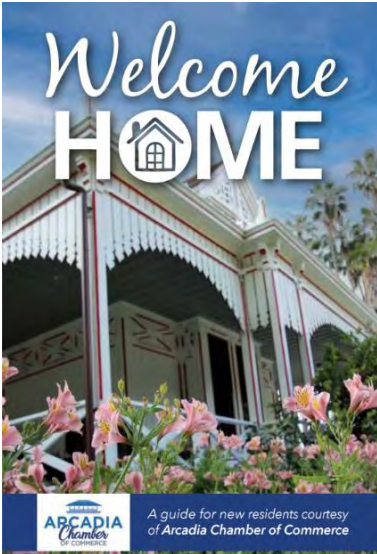

The Arcadia Chamber is hard at work on our upcoming Welcome Home booklet, as of the writing of this report. The printed booklet is slated to be completed and in-hand by July of this year. The Welcome Home publication, printed by Town Square, will be distributed to new home owners in the City of Arcadia. It will include information on the City, things to see and do, shopping and dining, education information, and more. A fundraising effort for the Arcadia Chamber, Town Square worked for months on selling ads to Chamber members who wanted to showcase their businesses to new home owners. As with our printed directory, Welcome Home will be produced every two years.

Another aspect of the Arcadia Chamber's community involvement, is our participation with local groups and organizations. Arcadia Chamber CEO Karen Mac Nair continues to sit on the Homeless Coalition Committee, along with the Downtown Arcadia Improvement Association Board. Director of Membership Sales Jose Luis attends the Arcadia Community Coordinating Council meetings, along with other events, networking organizations, and mixers put on throughout the San Gabriel Valley.

Jose Luis is very active around the community in general, attending ribbon cuttings and openings for businesses who are not members, to try and entice those businesses to join.



Chamber Staff - Karen, Carrie, Monica, and Jose Luis, at the 5K

Arcadia Chamber is also looking forward to joining the City of Arcadia and Santa Anita Park in welcoming the equestrian events for the 2028 Olympics.

*LinkedIn* (<https://www.linkedin.com/company/arcadia-ca-chamber-of-commerce/>)

To increase its presence on social media, the Chamber developed a LinkedIn company page, offering members, prospective members, and the business community new avenues to engage and expand their networking with the Chamber. LinkedIn helps promote Chamber events, showcases videos, and provides helpful information to followers.



## *Certificates of Origin*

Another source of revenue for the Chamber is Certificates of Origin. Import/export businesses have been very busy during the last few months of the year, so many members have been utilizing this service, sometimes on a weekly basis.

There are still members who join simply to use this service for their business.

Interesting companies that utilize the Certificate of Origin offerings are Rodarte, who ships extremely high-end fashion items (and creates many of the fashions you see on the runway at the Oscars and other large Hollywood events), and Flying Horses, who ships not only horses, but also goats and cows, and now zebras, to places all over the world.



The Arcadia Chamber is one of the only places around that currently offers Certificates of Origin, so this is a popular offering to our Chamber members.

## *Room Rentals*

Room Rentals continue to be on the rise, with multiple members and non-members coming back to utilize the conference room for board meetings, classes, and more. The Chabad of Arcadia and Calling Church both are consistent renters of the board room in recent months. The OB/GYN and Incontinence Center also hosted a well-attended women's wellness event. Room rental revenue from January through June totaled \$1,850.



## *ACE Awards & Board Installation 2026*

The Arcadia Chamber installed its 105<sup>th</sup> Board of Directors in February. Our new president is Christine Zito of Pure Media Marketing. Tyler Zikuski of the Derby comes in as secretary, and Brooke Perez of Longo Toyota is treasurer. Sina Mohajer of Mohajer law is our immediate past-president. The awards ceremony was Star Wars themed, with the tagline of *May the*

*Chamber be With You.*

The ACE Awards was held at the new Hilton Hotel Arcadia, which was a great way to showcase the new hotel itself and the great amenities it has, including a giant projection screen. The event was well attended and guests are still commenting on just how much fun they had.

2026 ACE Awards Winners include:

- Large Business of the Year - Longo Toyota
- Small Business of the Year - ServPro
- New Business of the Year - Whales Pressure Washing
- Non-Profit of the Year - Arcadia Community Coordinating Council
- Restaurant of the Year - The Derby
- Chamber Service Award - John Villa of Dance Syndicate
- Board Member of the Year - Christine Zito
- Ambassador of the Year - David Lamb
- Rising Star Member of the Year - Aire Serv



Congrats to all our winners!



## *Taste of Arcadia*

Taste of Arcadia will be held once again at Santa Anita Park on September 19<sup>th</sup>. Save the date for a great event! Interest is already coming in from members, including Ontario Airport, who hopes to create a unique lounge experience, and Lucid Motors, who has committed to bringing their cars.



## Continuing Community Improvement

Aside from fielding questions and providing assistance to Arcadia Chamber members, the Arcadia Chamber also assists in directing community members to various entities throughout the city and beyond. Examples include helping direct residents to public works when experiencing street light outages, water leaks, or potholes. The Arcadia Chamber also passed on two interested parties to the Firefighters Association, who wanted to learn how to become a sponsor of the Annual Pancake Breakfast, and when a resident called with issues getting a power box set up at their place of residence, the Arcadia Chamber was able to forward that to our representative at Southern California Edison, and within a couple days, the issue was completely resolved. Chamber staff even helped deflect an instance of spam with a customer of

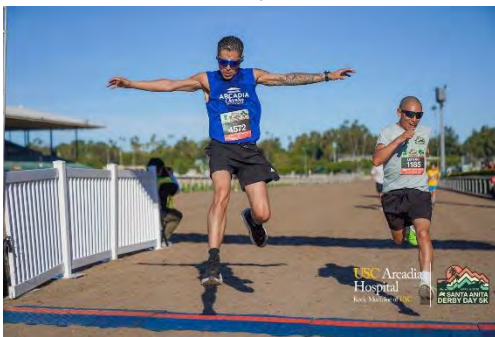

Southern California Edison, making sure the customer kept their info safe and Edison staff was informed of the incident. The Arcadia Chamber also assisted an Arcadia resident with Alzheimer’s who got lost and just happened to choose our office as a location to go to for help. Arcadia PD Dispatch was called and assisted the resident in getting home.

One never knows what types of calls will come in to the Arcadia Chamber of Commerce, and this includes people from all over the country who mistake our Arcadia Chamber for other Arcadias (there are 12+ cities and parishes called Arcadia). A few fun facts about other Arcadias - the Bonnie & Clyde Festival is held near Arcadia, Louisiana, and an antiquing mecca is located in Arcadia, Florida.

Many businesses also come into the Arcadia Chamber office or call to inquire about business licenses, community center classes, or thinking the building houses the Gilb Museum, so Chamber staff has become well-equipped in passing along the appropriate information, as needed. The unique shape of the Arcadia Chamber building must be the reason for this, as it certainly is iconic.



The Arcadia Chamber participates and markets for many different events and activities throughout the year to help not only promote the Chamber but to also keep actively engaged in the community. This April, the Chamber staff and other members joined up as the Chamber Turtles and ran/walked in the Santa Anita 5K.

In preparation for the 2028 LA Olympics, Arcadia Chamber staff has been attending Olympics meetings and sharing information about the upcoming events, ticket sales, and ways businesses

can get involved. The Chamber plans to host workshops on using RAMP. See our website here for info - <http://arcadiacachamber.org/la-olympics-2028/>

Jose Luis can often be found at events all over the community, networking and sharing about the Arcadia Chamber while trying to recruit new members.



In January of 2026, the Arcadia Chamber implemented yet another new networking event, called Lunch Link, held on the 2<sup>nd</sup> Tuesday of each month. This is a casual networking event, where guests can attend and buy as little or as much as they please (in line with Happy Hour Hops), and network at their leisure. Guests number between 10 and 30, depending on the location, and this event is quickly gaining popularity.



The Arcadia Chamber, as in years past, assisted with check-in at the Mayor's State of the City event in January at the Hilton Arcadia Hotel, and will continue to participate in the community event as needed.



## Looking Ahead – 2026 and beyond - Upcoming Chamber Events and Announcements

The Arcadia Chamber had its regularly scheduled events from January through June, including Rise & Shines, Networking at Noons, Happy Hour Hops, and many more.

In the next six months of 2026, the Arcadia Chamber also hopes to boost our Foundation Circle membership program, with new levels and benefits to try and entice different businesses to take part in these great opportunities. We will also be encouraging new Board Members to try different levels that fit their business needs.

During the late summer or early holiday season, the Arcadia Chamber hopes to host a job fair, in partnership with the Foothill Workforce Investment Board, utilizing our Chamber members who are looking to hire.



Jose Luis's Happy Hour Hop is in full swing, attracting upwards of 30+ guests at each event, both members and prospective members alike. Guests can register online, providing their contact info so Jose Luis can keep in touch and invite them to additional events. Members have reflected, post-event, how much fun Happy Hour Hop is and how it drives new clientele to their businesses.

The Morning Brew, one of the Arcadia Chamber's newest events, began in June 2025 on the first Wednesday of each month. This event has grown already to upwards of 30 to 40 guests

attending, and the popularity has attracted new members like Fika Fika Coffee and even our local Starbucks.

The Chamber is already hard at work on the upcoming Taste of Arcadia event, to be held September 19<sup>th</sup> at Santa Anita Park, recruiting food and drink vendors. Tickets went on sale on June 1<sup>st</sup>, and the buzz has begun!



As always, we are looking forward to an exciting year for the City of Arcadia and the Arcadia Chamber family of members!

## Special Events

<ul style="list-style-type: none"> <li>- Mayor's State of the City</li> </ul>	<ul style="list-style-type: none"> <li>- Strategic Planning Meeting</li> <li>- ACE Awards &amp; Board Installation Dinner</li> <li>- Kensington MIX</li> </ul>		<ul style="list-style-type: none"> <li>- Arcadia Chamber 4th Annual Golf Tournament</li> </ul>	<ul style="list-style-type: none"> <li>- Multi-Chamber MIX</li> </ul>	<ul style="list-style-type: none"> <li>- Mayor's State of the City</li> </ul>
<b>January</b>	<b>February</b>	<b>March</b>	<b>April</b>	<b>May</b>	<b>June</b>
<ul style="list-style-type: none"> <li>- Rise &amp; Shine Arcadia</li> <li>- Networking at Noon</li> <li>- Learning Lab</li> <li>- Happy Hour Hop</li> <li>- Morning Brew</li> <li>- Lunch Link</li> </ul>	<ul style="list-style-type: none"> <li>- Community Connection</li> <li>- Rise &amp; Shine Arcadia</li> <li>- Networking at Noon</li> <li>- Learning Lab</li> <li>- Connect &amp; Prosper</li> <li>- Happy Hour Hop</li> <li>- Morning Brew</li> <li>- Lunch Link</li> </ul>	<ul style="list-style-type: none"> <li>- Community Connection</li> <li>- Rise &amp; Shine Arcadia</li> <li>- Networking at Noon</li> <li>- Learning Lab</li> <li>- Connect &amp; Prosper</li> <li>- Happy Hour Hop</li> <li>- Morning Brew</li> <li>- Lunch Link</li> </ul>	<ul style="list-style-type: none"> <li>- Community Connection</li> <li>- Rise &amp; Shine Arcadia</li> <li>- Networking at Noon</li> <li>- Learning Lab</li> <li>- Happy Hour Hop</li> <li>- Morning Brew</li> <li>- Lunch Link</li> </ul>	<ul style="list-style-type: none"> <li>- Community Connection</li> <li>- Rise &amp; Shine Arcadia</li> <li>- Networking at Noon</li> <li>- Learning Lab</li> <li>- Happy Hour Hop</li> <li>- Morning Brew</li> <li>- Lunch Link</li> </ul>	<ul style="list-style-type: none"> <li>- Community Connection</li> <li>- Rise &amp; Shine Arcadia</li> <li>- Networking at Noon</li> <li>- Learning Lab</li> <li>- Connect &amp; Prosper</li> <li>- Happy Hour Hop</li> <li>- The Morning Brew</li> <li>- Lunch Link</li> </ul>

## Regular Chamber Events 2027



## Special Events

		<ul style="list-style-type: none"> <li>- Taste of Arcadia</li> </ul>	<ul style="list-style-type: none"> <li>- Downtown Arcadia Halloween Haunt</li> <li>- Moon Festival</li> <li>- State of the City</li> </ul>	<ul style="list-style-type: none"> <li>- Shop and Dine Arcadia</li> </ul>	<ul style="list-style-type: none"> <li>- Downtown Arcadia Holiday Fair</li> </ul>
<b>July</b>	<b>August</b>	<b>September</b>	<b>October</b>	<b>November</b>	<b>December</b>
<ul style="list-style-type: none"> <li>- Community Connection</li> <li>- Rise &amp; Shine Arcadia</li> <li>- Networking at Noon</li> <li>- Learning Lab</li> <li>- Happy Hour Hop</li> <li>- The Morning Brew</li> <li>- Lunch Link</li> </ul>	<ul style="list-style-type: none"> <li>- Community Connection</li> <li>- Rise &amp; Shine Arcadia</li> <li>- Networking at Noon</li> <li>- Learning Lab</li> <li>- Connect &amp; Prosper</li> <li>- Happy Hour Hop</li> <li>- The Morning Brew</li> <li>- Lunch Link</li> </ul>	<ul style="list-style-type: none"> <li>- Community Connection</li> <li>- Rise &amp; Shine Arcadia</li> <li>- Networking at Noon</li> <li>- Happy Hour Hop</li> <li>- The Morning Brew</li> <li>- Lunch Link</li> </ul>	<ul style="list-style-type: none"> <li>- Community Connection</li> <li>- Rise &amp; Shine Arcadia</li> <li>- Networking at Noon</li> <li>- Learning Lab</li> <li>- Connect &amp; Prosper</li> <li>- Happy Hour Hop</li> <li>- The Morning Brew</li> <li>- Lunch Link</li> </ul>	<ul style="list-style-type: none"> <li>- Community Connection</li> <li>- Rise &amp; Shine Arcadia</li> <li>- Networking at Noon</li> <li>- Learning Lab</li> <li>- Connect &amp; Prosper</li> <li>- Happy Hour Hop</li> <li>- The Morning Brew</li> <li>- Lunch Link</li> </ul>	<ul style="list-style-type: none"> <li>- Community Connection</li> <li>- Rise &amp; Shine Arcadia</li> <li>- Networking at Noon</li> <li>- Learning Lab</li> <li>- Connect &amp; Prosper</li> <li>- Happy Hour Hop</li> <li>- The Morning Brew</li> <li>- Lunch Link</li> </ul>

## Regular Chamber Events 2026

<b>Monthly Meetings:</b> Ambassadors Board Executive Team Events Committee Membership Policy and By-laws Taste of Arcadia Sponsorship Committee Golf Tournament Committee	<b>ABC Groups:</b> Members Only 5 Groups who Meet Once Per Month to Network	<b>Taste Committee:</b> Meets Once Per Month to Plan Taste of Arcadia, from January through September	<b>Ribbon Cuttings:</b> Scheduled at Random at the Request of Chamber Members	<b>Golf Committee:</b> Meets Once Per Month to Plan Taste of Arcadia, from January through September
--	---	---	--	--

# Arcadia Chamber Stats

Social Media & Chamber Chat Followers





**Morning Brew**  
Avg. Attendance - 30  
Total Events - 6





**Happy Hour Hop**  
Avg. Attendance - 35  
Total Events - 6



**Rise & Shine**  
Avg. Attendance 55  
Total Events 6

**Networking at Noon**  
Avg. Attendance 45  
Total Events 6



**ARCADIA Chamber OF COMMERCE**

**MONTHLY EVENTS STATISTICS**  
January through June

**Learning Lab**  
Avg. Attendance 15  
Total Events 4

**Ribbon Cuttings**  
Avg. Attendance 25  
Total Events 7







# Attachment No. 2

Chamber Annual Financial Summary for  
Fiscal Year 2025-26

# ARCADIA CHAMBER OF COMMERCE

Balance Sheet  
As of Apr 30, 2026

	Total
<b>Assets</b>	
Current Assets	
Bank Accounts	
1-1010 Cash on Hand	2,274.96
1-1015 BMO Savings	507.01
1-1020 Reserves - FCU - 90	102,641.07
1-1025 BMO Checking	2,991.00
1-1030 Events Account -CBB-0655	2,725.78
1-1040 Foothill Checking - 03	26,701.57
<b>Total for Bank Accounts</b>	<b>\$137,841.39</b>
Accounts Receivable	
1-1200 Accounts Receivable	-60.00
<b>Total for Accounts Receivable</b>	<b>-\$60.00</b>
Other Current Assets	
1-1350 Atlas Receivables	
Boardroom Rental	-50.00
Classic - Annual	22,691.88
Classic - Monthly	280.28
Classic - New	298.00
Connect & Prosper	115.00
Email Blast	225.00
Fall Event - Dine / Taste	3,500.00
Golf Tournament	24,185.98
Installation Dinner	425.00
Mix	545.00
Networking at Noon	-65.00
Rise & Shine	3,600.00
<b>Total for 1-1350 Atlas Receivables</b>	<b>\$55,751.14</b>
1-1400 Prepaid Expenses	
1-1420 Prepaid TofA Expenses	3,962.18
<b>Total for 1-1400 Prepaid Expenses</b>	<b>\$20,853.39</b>
1-1700 Undeposited Funds	
Portal Inventory Asset	3,000.00
<b>Total for Other Current Assets</b>	<b>\$79,634.53</b>
<b>Total for Current Assets</b>	<b>\$217,415.92</b>
Fixed Assets	
1-1910 Furniture & Fixtures	4,964.00

# ARCADIA CHAMBER OF COMMERCE

Balance Sheet  
As of Apr 30, 2026

	Total
1-1920 Equipment	6,638.00
1-1930 Computer	5,165.00
1-1940 Accumulated Deprec.	-16,767.00
<b>Total for Fixed Assets</b>	<b>\$0.00</b>
<b>Total for Assets</b>	<b>\$217,415.92</b>
<b>Liabilities and Equity</b>	
Liabilities	
Current Liabilities	
Accounts Payable	
2-2000 Accounts Payable	656.00
<b>Total for Accounts Payable</b>	<b>\$656.00</b>
Credit Cards	
2-2050 Foothill Credit Card	2,920.24
<b>Total for Credit Cards</b>	<b>\$2,920.24</b>
Other Current Liabilities	
2-2100 Prepaid Revenue	\$29,548.50
2-2110 Prepaid Fall Event - Dine Arcadia / Taste Revenue	11,863.65
2-2120 Prepaid Installation Revenue	533.32
2-2180 Prepaid Rise & Shine Revenue	6,472.00
2-2190 Prepaid Member Dues Revenue	19,846.44
<b>Total for 2-2100 Prepaid Revenue</b>	<b>\$68,263.91</b>
2-2500 Arcadia Strong Grant Funds	111.64
2-2550 Arcadia StrongER Program Funds	3,940.00
<b>Total for Other Current Liabilities</b>	<b>\$72,315.55</b>
<b>Total for Current Liabilities</b>	<b>\$75,891.79</b>
Long-term Liabilities	
2-2700 SBA Loan	16,435.00
<b>Total for Long-term Liabilities</b>	<b>\$16,435.00</b>
<b>Total for Liabilities</b>	<b>\$92,326.79</b>
Equity	
3-3000 Opening Bal Equity	3,000.00
3-3110 Retained Earnings	120,671.26
Net Income	1,417.87
<b>Total for Equity</b>	<b>\$125,089.13</b>
<b>Total for Liabilities and Equity</b>	<b>\$217,415.92</b>

# ARCADIA CHAMBER OF COMMERCE

Profit and Loss  
July, 2025-April, 2026

	Total
<b>Income</b>	
4-1000 Member Dues	
4-1100 Renewing Members	
4-1110 Classic Membership	80,377.00
4-1115 Classic Monthly	11,612.80
4-1120 Signature Membership	1,009.15
4-1130 Premium Membership	1,422.87
4-1140 Connector Membership	3,645.90
4-1145 Connector Monthly	525.10
4-1150 Supporter Membership	1,120.84
4-1160 Leader Membership	5,102.03
4-1170 Visionary Membership	17,420.00
4-1185 Bundled Membership Dues	1,716.84
4-1190 Arcadia StrongER - Renewals	325.00
<b>Total for 4-1100 Renewing Members</b>	<b>\$124,277.53</b>
4-1300 New Members	
4-1310 Classic Member	21,970.00
4-1313 Arcadia StrongER Grant Recipients	6,175.00
4-1315 Taste Membership	400.00
<b>Total for 4-1300 New Members</b>	<b>\$28,545.00</b>
<b>Total for 4-1000 Member Dues</b>	<b>\$152,822.53</b>
4-2000 Sponsorships	
4-2025 Board Meeting Sponsor	1,500.00
<b>Total for 4-2000 Sponsorships</b>	<b>\$1,500.00</b>
4-3000 Events	
4-3100 Monthly Events	
4-3110 Rise & Shine	
4-3111 Rise & Shine Tickets	14,955.00
4-3112 Upgraded Membership Portion	8,445.00
4-3114 Rise & Shine Sponsor	7,566.68
4-3115 Rise & Shine Business Booth	200.00

# ARCADIA CHAMBER OF COMMERCE

Profit and Loss  
July, 2025-April, 2026

	Total
<b>Total for 4-3110 Rise &amp; Shine</b>	<b>\$31,166.68</b>
4-3120 Networking at Noon	
4-3121 Tickets	11,575.00
4-3122 Upgraded Membership Portion	5,810.00
4-3123 Sponsor	2,750.00
<b>Total for 4-3120 Networking at Noon</b>	<b>\$20,135.00</b>
4-3160 Learning Lab	
4-3161 Learning Lab Ticket	165.00
4-3163 Learning Lab Sponsor	1,250.00
<b>Total for 4-3160 Learning Lab</b>	<b>\$1,415.00</b>
4-3170 Connect & Prosper	
4-3171 Connect & Prosper Tickets	1,600.00
4-3172 Connect & Prosper Sponsorship	3,750.00
4-3173 Upgraded Membership Portion	1,085.00
<b>Total for 4-3170 Connect &amp; Prosper</b>	<b>\$6,435.00</b>
4-3190 The Mix	
4-3191 Tickets	7,170.00
<b>Total for 4-3190 The Mix</b>	<b>\$7,170.00</b>
<b>Total for 4-3100 Monthly Events</b>	<b>\$66,321.68</b>
4-3200 Annual Events	
4-3220 Installation Dinner	
4-3221 Installation Dinner Tickets	6,500.00
4-3224 Installation Dinner Program Ads	400.00
4-3225 Installation Dinner Sponsor	10,250.00
4-3226 Upgraded Membership Portion	2,191.58
4-3227 Raffle Ticket Income	1,470.00
<b>Total for 4-3220 Installation Dinner</b>	<b>\$20,811.58</b>
4-3250 Taste of Arcadia	
4-3252 Taste of Arcadia Online Tickets	16,637.81
4-3254 Taste of Arcadia VIP Tables	12,900.00
4-3255 Taste of Arcadia Business Showcase Spaces	17,625.00
4-3256 Taste of Arcadia Auto Showcase Spaces	2,975.00
4-3258 Taste of Arcadia Sponsors	32,700.00
4-3262 Upgraded Membership Portion	280.00
4-3263 Food Booth Deposit	975.00

# ARCADIA CHAMBER OF COMMERCE

Profit and Loss  
July, 2025-April, 2026

	Total
<b>Total for 4-3250 Taste of Arcadia</b>	<b>\$84,092.81</b>
4-3700 Golf Tournament Event	
4-3710 Golfers Tickets	24,000.00
4-3715 Raffle Ticket	
4-3716 Golf 50/50 Raffle Ticket	6,260.00
4-3717 Golf Prize Raffle Ticket	3,835.00
4-3719 Golf Silent Auction	1,625.00
<b>Total for 4-3715 Raffle Ticket</b>	<b>\$11,720.00</b>
4-3720 Golf Tournament Sponsorships	38,000.00
<b>Total for 4-3700 Golf Tournament Event</b>	<b>\$73,720.00</b>
4-3750 Moon Festival Booths	2,225.00
<b>Total for 4-3200 Annual Events</b>	<b>\$180,849.39</b>
<b>Total for 4-3000 Events</b>	<b>\$247,171.07</b>
4-4000 City Payments	84,275.83
4-5000 Other Income	\$113.59
4-5010 110% Club Income	9,991.25
4-5020 Boardroom Rental	2,850.00
4-5030 Certificate of Origin	350.00
4-5040 Interest Income	503.87
4-5080 Other Income	12,350.00
4-5090 Email Blast Revenue	675.00
<b>Total for 4-5000 Other Income</b>	<b>\$26,833.71</b>
<b>Total for Income</b>	<b>\$512,603.14</b>
<b>Cost of Goods Sold</b>	
5-0000 Other Costs of Services - COS	
5-1000 Costs of Member Dues	
5-1100 Renewing Member	
5-1110 Bank Charge Costs	9,349.29
5-1120 Intuit Costs	36.30
<b>Total for 5-1100 Renewing Member</b>	<b>\$9,385.59</b>
<b>Total for 5-1000 Costs of Member Dues</b>	<b>\$9,385.59</b>

# ARCADIA CHAMBER OF COMMERCE

Profit and Loss  
July, 2025-April, 2026

	Total
5-3000 Costs of Events	
5-3100 Monthly Events	
5-3110 Rise & Shine	
5-3114 Location Costs	15,261.48
5-3115 Entertainment Costs	2,700.00
<b>Total for 5-3110 Rise &amp; Shine</b>	<b>\$17,961.48</b>
5-3120 Networking at Noon	
5-3122 Location Costs	8,366.57
<b>Total for 5-3120 Networking at Noon</b>	<b>\$8,366.57</b>
5-3160 Learning Lab	
5-3161 LL Location Costs	504.75
<b>Total for 5-3160 Learning Lab</b>	<b>\$504.75</b>
5-3170 Connect & Prosper	
5-3171 CP Location Costs	1,758.88
<b>Total for 5-3170 Connect &amp; Prosper</b>	<b>\$1,758.88</b>
5-3190 The MIX	
5-3196 Location Costs	1,777.78
<b>Total for 5-3190 The MIX</b>	<b>\$1,777.78</b>
<b>Total for 5-3100 Monthly Events</b>	<b>\$30,369.46</b>
5-3200 Annual Events	
5-3220 Installation Dinner	
5-3221 Location Costs	10,358.71
5-3225 Invitation Costs	75.00
5-3226 Banner Costs	469.63
5-3228 Gifts Costs	276.25
5-3230 Centerpieces Costs	312.88
5-3231 Programs Costs	513.00
5-3234 Website	600.00
5-3237 Advertising	126.40
5-3241 50/50 Raffle Split	500.00
5-3242 Part-Time Staff (Monica)	8,644.31

# ARCADIA CHAMBER OF COMMERCE

Profit and Loss  
July, 2025-April, 2026

	Total
<b>Total for 5-3220 Installation Dinner</b>	<b>\$21,876.18</b>
5-3250 Taste of Arcadia	
5-3251 Location Costs	6,999.34
5-3255 Entertainment Costs	828.75
5-3257 Equipment Rental Costs	26,194.48
5-3258 Permit & License Costs	75.00
5-3259 Food Booth Supplies Costs - Cups/Ice	9,838.52
5-3260 Wine Glasses Costs	1,632.78
5-3261 Plates Costs	2,471.57
5-3263 Meeting & Meal Costs	496.15
5-3266 Centerpiece Costs	494.72
5-3268 Advertising Costs	1,992.54
5-3270 Banners Costs	5,343.41
5-3277 Seasonal Labor Costs	5,560.39
5-3278 Independent Labor Costs - Accounting	368.00
5-3280 TofA Bags	3,620.77
5-3281 TofA Posters	138.13
5-3282 TofA Website Costs	171.19
5-3285 TofA Health Dept Costs	3,367.49
<b>Total for 5-3250 Taste of Arcadia</b>	<b>\$69,593.23</b>
5-3700 Golf Tournament Expenses	
5-3710 Golf Tournament Advertising	44.20
5-3715 Golf Tournament Location Expenses	11,520.00
5-3720 Golf Tournament Food Expenses	15,725.84
5-3735 Golf Tournament Giveaways Expenses	1,849.73
5-3740 Golf Tournament Printing Expenses	2,491.78
5-3745 Golf Tournament Supplies	401.06
5-3750 50/50 Raffle Ticket Split	2,925.00
5-3755 Golf Tournament Labor	8,091.31
5-3760 Special Event Insurance	362.25
5-3765 ABC License	75.00
5-3770 Golf Meeting	117.13
<b>Total for 5-3700 Golf Tournament Expenses</b>	<b>\$43,603.30</b>

# ARCADIA CHAMBER OF COMMERCE

Profit and Loss  
July, 2025-April, 2026

	Total
<b>Total for 5-3200 Annual Events</b>	<b>\$135,072.71</b>
<b>Total for 5-3000 Costs of Events</b>	<b>\$165,442.17</b>
<b>Total for 5-0000 Other Costs of Services - COS</b>	<b>\$174,827.76</b>
<b>Total for Cost of Goods Sold</b>	<b>\$174,827.76</b>
<b>Gross Profit</b>	<b>\$337,775.38</b>
<b>Expenses</b>	
6-0000 Expenses	
6-1000 Labor Expenses.	
6-1100 Gross Wages - Operations	\$45,767.21
6-1105 Bonus	1,000.00
<b>Total for 6-1100 Gross Wages - Operations</b>	<b>\$46,767.21</b>
6-1110 Gross Wages - Assist Director	\$57,312.00
6-1112 Bonus	1,000.00
<b>Total for 6-1110 Gross Wages - Assist Director</b>	<b>\$58,312.00</b>
6-1120 Gross Wages - Officers	\$73,548.00
6-1125 Bonus	1,500.00
<b>Total for 6-1120 Gross Wages - Officers</b>	<b>\$75,048.00</b>
6-1300 ER Payroll Tax Expense - Operations	4,281.65
6-1305 ER Payroll Tax Expense - Assist Director	5,093.92
6-1315 ER Payroll Tax Expense - Officers	6,531.80
6-1500 Payroll Processing Fee	5,485.32
6-1600 Health Insurance	17,875.00
6-1610 Cell Phone Reimbursement	1,565.88
6-1620 Internet Reimbursement	1,352.70
6-1630 Mileage Reimbursement	3,637.26
6-1700 Workers Comp Insurance	969.04
<b>Total for 6-1000 Labor Expenses.</b>	<b>\$226,919.78</b>
6-2000 Independent Contractors	
6-2100 Accounting Expense	31,668.00
6-2175 Retirement Consulting Fees	750.00
6-2500 Website Maintenance Expense	870.00
6-2600 IT Maintenance Expense	2,700.00
<b>Total for 6-2000 Independent Contractors</b>	<b>\$35,988.00</b>

# ARCADIA CHAMBER OF COMMERCE

Profit and Loss  
July, 2025-April, 2026

	Total
6-3000 Overhead Expenses	
6-3100 Rent Expense	4,400.00
6-3200 Utilities Expense	6,043.44
6-3300 Repairs and Maintenance Expense	203.00
6-3400 Property Taxes Expense	819.24
6-3500 Janitorial Expense	4,555.14
6-3600 Insurance Expense	\$42.00
6-3610 Umbrella Policy	5,301.68
6-3620 Director & Officers	1,125.46
<b>Total for 6-3600 Insurance Expense</b>	<b>\$6,469.14</b>
<b>Total for 6-3000 Overhead Expenses</b>	<b>\$22,489.96</b>
6-4000 Operational Expenses	
6-4100 Bad Debts Expense	
6-4101 Business	17,608.00
6-4105 Visionary Fund	979.50
<b>Total for 6-4100 Bad Debts Expense</b>	<b>\$18,587.50</b>
6-4120 Telephone / Internet / Email Expense	4,180.34
6-4130 Postage Expense	183.65
6-4140 Printing Expense	1,347.83
6-4150 Equipment Rental Expense	3,438.23
6-4160 Equipment Purchase Expense	
6-4161 Insurance Charge	6.00
<b>Total for 6-4160 Equipment Purchase Expense</b>	<b>\$6.00</b>
6-4180 Dues and Subscriptions Expense	274.04
6-4190 Office Supplies Expense	2,038.37
6-4200 Computer Software Expense	9,468.18
6-4210 Meals and Entertainment Expense	1,294.43
6-4220 Community Event Expense	104.99
6-4240 Advertising / Website Expenses	1,520.91
6-4245 Facebook / Instagram Boosts	8,500.00
6-4260 Business License Expense	15.30
<b>Total for 6-4000 Operational Expenses</b>	<b>\$50,959.77</b>
<b>Total for 6-0000 Expenses</b>	<b>\$336,357.51</b>
<b>Total for Expenses</b>	<b>\$336,357.51</b>
<b>Net Operating Income</b>	<b>\$1,417.87</b>
<b>Net Income</b>	<b>\$1,417.87</b>

# Attachment No. 3

Agreement for Services for Fiscal Year  
2026-27

**AGREEMENT FOR SERVICES BY AND BETWEEN THE  
CITY OF ARCADIA AND ARCADIA CHAMBER OF COMMERCE  
FOR FISCAL YEAR 2026-27**

This Agreement for Services ("Agreement") is entered into this \_\_\_\_\_ day of \_\_\_\_\_ 2026 by and between the Arcadia Chamber of Commerce ("Chamber"), a not-for-profit organization, and the City of Arcadia ("City"), a municipal corporation and charter city.

RECITALS

- A. The City and the Chamber have long cooperated concerning issues and projects of mutual interest to the Arcadia civic and business community.
- B. The Chamber has in the past provided, and desires and intends to provide in the City's fiscal year ("fiscal year") 2026-2027, various services to the City, as described hereinafter.
- C. For many years, the City has, pursuant to a certain lease entered into by the City and the Chamber (the "Lease"), provided to the Chamber at a below market lease rate the full use of a certain City-owned building at 388 West Huntington Drive, Arcadia ("Leased Premises"), in support and recognition of the Chamber's ongoing services to the City, and the Lease extends through November 31, 2026.
- D. The City desires and intends to make payment to the Chamber in the amount of \$104,367 for certain business and economic development, marketing, civic promotion, and similar services to be provided by the Chamber to the City during Fiscal Year 2026-2027, as set forth in Exhibit "A" attached hereto (the "Services").
- E. The Chamber desires and intends to provide the Services to the City in consideration for the City's payments and appropriation of funds as described herein.

## AGREEMENT

Now, therefore, the City and the Chamber do hereby agree that the foregoing Recitals are true and correct and are incorporated into this Agreement, and made a part thereof as if fully set forth herein, and further agree as follows:

### A. Responsibilities of the Chamber

1. The Chamber is and shall serve as an independent organization entirely separate from the City, and shall operate under its own bylaws as a membership organization serving the interests of business in the greater Arcadia area. For purposes of this Agreement, the Chamber is and in all respects shall be deemed to be an independent contractor.
2. The Chamber shall provide to the City during Fiscal Year 2026-2027 the Services set forth in Exhibit "A" attached hereto and incorporated herein by reference.
3. The Chamber shall submit to the City a written progress report in December of 2026, and again in May of 2027 describing in reasonable detail the Chamber's performance and provision of the Services under this Agreement for the period July 1, 2026 through the date of said reports.

### B. Responsibilities of the City

1. In consideration of the provision of the Services by the Chamber to the City during Fiscal Year 2026-2027, the City shall make (1) payment to the Chamber of the sum of one-hundred and one thousand one hundred and thirty one dollars (\$104,367), payable in equal quarterly installments, the first of which is due on or before July 1, 2026 (the "Payment for Services") and each subsequent payment due on or before the first date of the quarterly month.

### C. Review and Inspection of Chamber Records

1. On or before September 30, 2026, the Chamber shall provide to the City a complete and accurate financial statement of the Chamber for Fiscal Year 2025-2026 (i.e., ending June 30, 2026).
2. The City and its representatives shall have the right to review and/or audit the records of the Chamber to verify that the Chamber is providing the Services and making reasonable and appropriate expenditures from the Payment for Services in furtherance of providing the Services. For this purpose, the Chamber shall make available to the City and its representatives all records of the Chamber to allow the accomplishment of review and audit during normal business hours of the City, upon reasonable demand by the City.

D. Amendment

1. This Agreement may be amended by mutual written consent of the parties.

E. Termination

1. This Agreement shall be deemed to commence on July 1, 2026 and shall extend through June 30, 2027 (the "Term"). This Agreement may be terminated earlier by either party giving the other party written notice of termination; provided that such notice of termination shall be given at least 180 days prior to the effective date of termination and shall be transmitted by email, facsimile, U.S. mail, or personal delivery to the person or persons occupying the indicated position(s) of the other party signing this Agreement. The rights, duties, and responsibilities of the City and the Chamber shall continue for the period between the Notice of Termination and the effective date of termination. Any portion of the Payment for Services due and owing to the Chamber following such notice of termination shall be prorated to cover only the period up to the effective date of termination, and any portion of the Payment for Services already made to the Chamber for the remainder of the period following the effective date of termination shall be prorated and promptly refunded to the City by the Chamber to cover the period following the effective date of termination. Notwithstanding any provision of this Agreement to the contrary, Section C of this Agreement entitled, "Review and Inspection of Chamber Records" shall survive the Term and any termination of this Agreement.

F. California Law

1. This Agreement shall be governed by the laws of the State of California.

[SIGNATURES ON NEXT PAGE]

In witness whereof, the Parties have executed this Agreement as of the date first set forth herein above.

CHAMBER:

CITY OF ARCADIA:

\_\_\_\_\_  
President  
Arcadia Chamber of Commerce

\_\_\_\_\_  
Dominic Lazzaretto  
City Manager

\_\_\_\_\_  
Chief Executive Officer  
Arcadia Chamber of Commerce

APPROVED AS TO FORM:

\_\_\_\_\_  
City Attorney

ATTEST:

\_\_\_\_\_  
City Clerk

## EXHIBIT "A"

### SERVICES PROVIDED BY ARCADIA THE CHAMBER OF COMMERCE TO THE CITY OF ARCADIA

Fiscal Year 2026-2027

The Chamber shall provide the following services to the City:

#### I. Public Relations

- A. Maintain regular office hours with qualified personnel.
- B. Provide accurate and timely information and market the City and business areas to hundreds of residents and business people who walk-in, phone, write, or e-mail the Chamber each month.
- C. Prepare and maintain the monthly community calendar of civic group events.
- D. Provide information on Arcadia to realtors and commercial brokers to assist with business recruitment, business retention, and new commercial development.
- E. Prepare and make available a civic directory which lists all civic, cultural, social, educational, and business groups, addresses, meeting dates, etc.
- F. Through the Board and Committee structure (e.g., Ambassador Meetings, Chamber Board Meetings), and Chamber functions (e.g., Business Mixers, Networking Breakfasts, Community Connection Meetings, Arcadia Chamber Excellence Awards, State of the City), and other various legislative gatherings and forums, bring civic leaders and City/Agency staff together with business people and citizens every month.
- G. Maintain social media network to promote Chamber, City, and business activities and news, including Chamber web site with calendar, Facebook, Instagram, X, and any new effective technologies.

#### II. Business Development

- A. Organize and host business expos and in-person job fairs to market Chamber business member products and services to each other and to the community, including at the city's annual Moon Festival. The City will be provided free and prominent space at these events.
- B. Prepare and print (approximately every other year) a Business Directory and City Map that includes economic and civic information on Arcadia.

Provide and distribute copies of the Directory and Map to the City, Chamber Members, businesses and residents, local community and civic organizations, and hotels.

- C. Conduct special community and business forums, e.g., Trash/Recycling pick-up events, or assist City to inform the community of meetings, e.g., community workshops on large development projects, proposed city measures, initiatives and propositions, transportation concerns, etc.
- D. Organize Taste of Arcadia, a tasting event with local restaurants and a business showcase, during the month of September 2026 to be held at Santa Anita Park.
- E. Assist the City during emergencies, by providing a liaison at Emergency Operations Center; coordinating with the City EOC & Red Cross and Emergency Centers throughout the City in the event of earthquake or disaster; working with Chamber Emergency Business Preparedness plan for emergencies; and supporting the City during emergencies by providing relevant information to the business community.
- F. Provide ambassadors to existing and new businesses throughout the year to monitor concerns, assist in resolving problems with the Chamber or the City, meet other Arcadia businesses (e.g., monthly networking / orientation / breakfasts).
- G. Work actively on business recruitment, expansion and retention efforts throughout the City.
- H. Organize and publicize seminars and training sessions for merchants and business members under SBA, SCORE, SGVEP, Foothill Workforce Investment Board, Women at Work, and other governmental and educational programs.
- I. Continue to work with Downtown Arcadia Improvement Association on the downtown community benefits district, district marketing efforts, and events.
- J. As needed or requested by the City, conduct membership survey on general business topics, e.g., parking, ride-share, recycling, signage, etc. to inform the City of business concerns
- K. Work with other business areas on Live Oak Avenue, Duarte Road, Baldwin Avenue, Foothill Boulevard, Peck Road/Lower Azusa, and other sectors to initiate regular events and marketing.
- L. Continue to develop new media marketing opportunities for business members through the Chamber.

III. Government/Legislative

- A. Through the monthly Community Connection meetings, provide business information to Chamber members and serve as a forum for City, County, State and Federal interrelationships and dialogue.
- B. Review and recommend proposed business legislation and concerns to City.
- C. Coordinate with city staff to organize the annual “State of the City” event each year.

**DATE:** June 16, 2026

**TO:** Honorable Mayor and City Council

**FROM:** Paul Cranmer, Public Works Services Director  
By: Kyle Go, Engineering Assistant

**SUBJECT:** CONTRACT WITH MISSION PAVING AND SEALING, INC. FOR THE FISCAL YEAR 2025-26 ANNUAL SLURRY SEAL PROJECT IN THE AMOUNT OF \$754,125

**CEQA: Exempt**

**Recommendation: Approve**

### **SUMMARY**

As part of the City's annual Asphalt and Concrete Program, the Public Works Services Department ("PWSD") is preparing to slurry seal various residential streets within Arcadia. The proposed area can generally be described as the residential neighborhoods in the northwest corner of the City (within City Council District 2). To ensure that the City is receiving the most competitive price and quality service for this work, the PWSD conducted a formal bid process, and Mission Paving and Sealing, Inc. submitted the lowest responsive bid.

It is recommended that the City Council approve, authorize, and direct the City Manager to execute a contract with Mission Paving and Sealing, Inc. for the Fiscal Year 2025-26 Annual Slurry Seal Project, in the amount of \$754,125, with a 10% contingency.

### **BACKGROUND**

The PWSD is responsible for the maintenance and repair of approximately 147 miles of roadway within the City. The 2021 Pavement Management Program update assessed the condition of all City streets and assigned a numerical index between 0 and 100, which is used to indicate the general condition of pavement. The annual Slurry Seal Maintenance Program assists in extending the useful life of the pavement

and improves the overall appearance and safety of City streets. This program provides surface maintenance for all City streets and divides Arcadia into eight zones, with one zone being addressed each year as part of an eight-year cycle. Updates to the plan are conducted regularly to ensure that the program is effective and to identify street segments with unusual wear and tear.

**DISCUSSION**

The Fiscal Year 2025-26 Annual Slurry Seal Project will address approximately 16.5 miles of residential and arterial streets, as shown on the attached Project Location Map (Exhibit “A”). The project area includes streets north of the 210 Foothill Freeway from the west City Limits to Santa Anita Avenue. The work includes crack sealing, the application of an emulsified asphalt and sand coating, commonly referred to as slurry, and the re-striping of street centerlines, stop bars, and other safety striping. This process protects the asphalt pavement surface from weather, restores skid resistance, and provides an aesthetic improvement to the roadway. Unlike pavement rehabilitation projects, recycled rubber mix is not used for slurry sealing of streets due to the significantly higher cost of the material. It has also been determined that the emulsified asphalt sand coating material provides a strong barrier for several years and is best used on street sections with a higher Pavement Condition Index (“PCI”). Streets with low PCIs require more extensive rehabilitation, such as full pavement reconstruction.

A Notice Inviting Bids was published in accordance with City Council Resolution No. 7483, and bid packages were provided to contractors that perform this type of work. On April 28, 2026, the City received seven sealed bids with the following results:

<b>Rank</b>	<b>Firm</b>	<b>Location</b>	<b>Base Bid</b>
1.	Mission Paving and Sealing, Inc.	Irwindale	\$754,125.00
2.	American Asphalt South, Inc	Riverside	\$784,195.85
3.	Roy Allan Slurry Seal Inc.	Sante Fe Springs	\$784,434.75
4.	Pavement Coatings Co.	Jurupa Valley	\$821,540.00
5.	All American Asphalt	Corona	\$827,730.00
6.	Union Pavement Services, Inc.	Jurupa Valley	\$894,470.00
7.	Doug Martin Contracting Co., Inc.	La Habra	\$915,509.00

Bid documents were reviewed for content and the contractors' background and recent projects were investigated. Based on this review, it has been determined that Mission Paving and Sealing, Inc. is the lowest responsive bidder for this work. Mission Paving and Sealing, Inc. has successfully completed similar work within budget for Arcadia as well as the Cities of Los Angeles, Seal Beach, Costa Mesa, Santa Ana, Murrieta, and Woodland Hills.

### **ENVIRONMENTAL ANALYSIS**

This project is considered a Class 1 exemption as defined in Section 15301(c) of the California Environmental Quality Act, since the project consists of the maintenance of existing public streets and does not involve expansion of the existing use.

### **FISCAL IMPACT**

Funds in the amount of \$1,350,000 have been budgeted in the Fiscal Year 2025-26 Capital Improvement Program for the Annual Slurry Seal Program. The total cost for this Project is \$754,125, and a 10% construction contingency would bring the total cost to \$829,537.50, which is within the adopted budget.

### **RECOMMENDATION**

It is recommended that the City Council determine that this project is a Class 1 exemption under the California Environmental Quality Act ("CEQA"); and approve, authorize, and direct the City Manager to execute a contract with Mission Paving and Sealing, Inc. for the Fiscal Year 2025-26 Annual Slurry Seal Project in the amount of \$754,125, with a 10% contingency.

Approved:



Dominic Lazzaretto  
City Manager

Attachments: Exhibit "A" - Project Location Map  
Proposed Contract



**2025/2026 ANNUAL SLURRY SEAL PROJECT**  
**PROJECT NO.: 55331026**  
**EXHIBIT "A" - PROJECT LOCATION MAP**

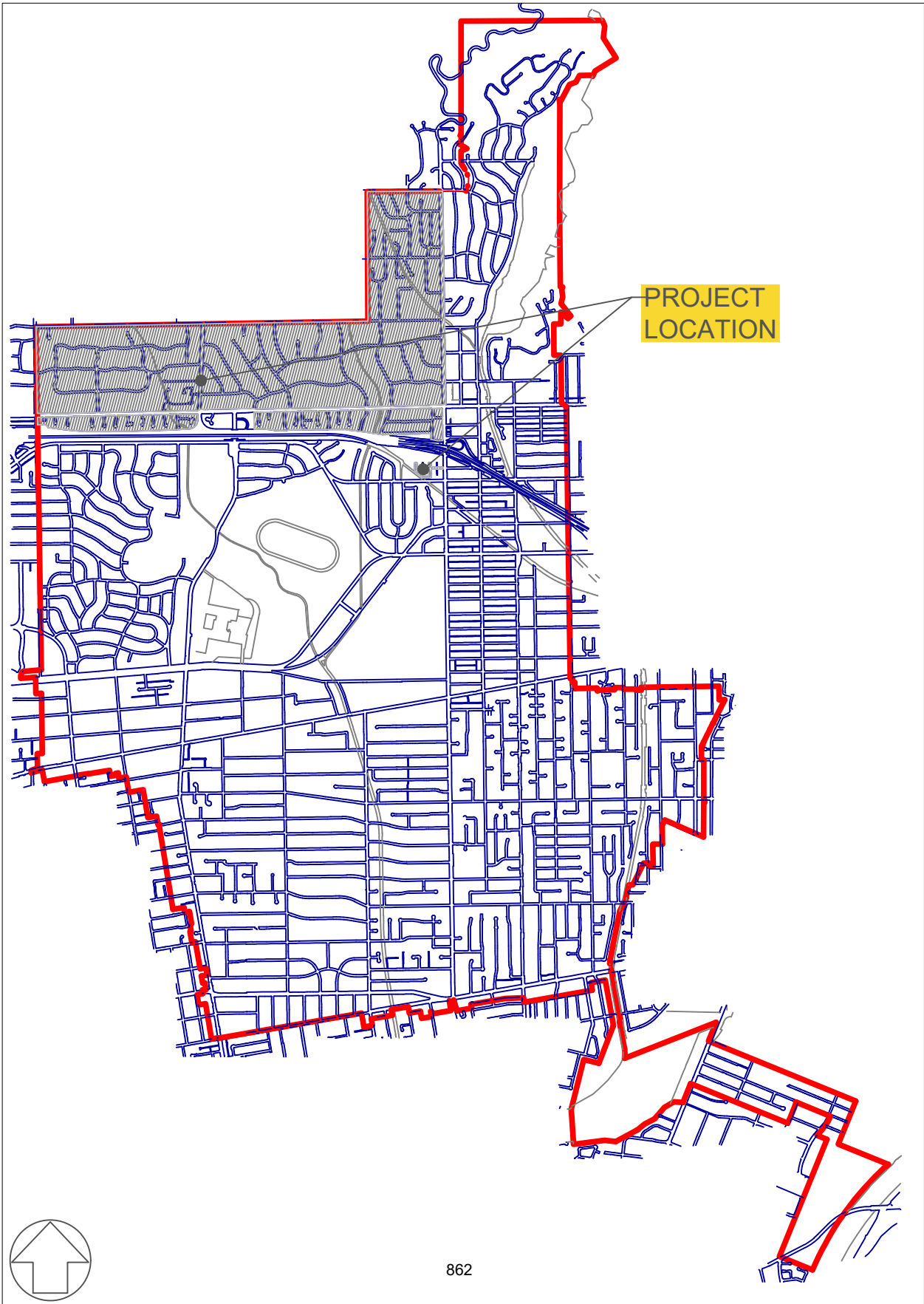

**CITY OF ARCADIA**

**2025/2026 ANNUAL SLURRY SEAL PROJECT  
PROJECT No.: 55331026**

**CONTRACT**

**BETWEEN  
CITY OF ARCADIA  
AND  
MISSION PAVING AND SEALING, INC.**

**CONTRACT FOR THE  
CITY OF ARCADIA**

This CONTRACT, No. \_\_\_\_\_ is made and entered into this \_\_\_\_ day of \_\_\_\_\_, \_\_\_\_\_, by and between City of Arcadia, sometimes hereinafter called "City," and **Mission Paving and Sealing, Inc.**, sometimes hereinafter called "Contractor."

WITNESSETH: That the parties hereto have mutually covenanted and agreed, and by these presents do covenant and agree with each other as follows:

**A. SCOPE OF WORK.** The Contractor shall perform all Work within the time stipulated in the Contract, and shall provide all labor, materials, equipment, tools, utility services, and transportation to complete all of the Work required in strict compliance with the Contract Documents as specified in Article 5, below, for the following Project:

**2025/2026 Annual Slurry Seal Project / Project No.: 55331026**

The Contractor and its surety shall be liable to the City for any damages arising as a result of the Contractor's failure to comply with this obligation.

**B. TIME FOR COMPLETION.** Time is of the essence in the performance of the Work. The Work shall be commenced on the date stated in the City's Notice to Proceed. The Contractor shall complete all Work required by the Contract Documents within **Sixty (60)** calendar days from the commencement date stated in the Notice to Proceed. By its signature hereunder, Contractor agrees the time for completion set forth above is adequate and reasonable to complete the Work.

**C. CONTRACT PRICE.** The City shall pay to the Contractor as full compensation for the performance of the Contract, subject to any additions or deductions as provided in the Contract Documents, and including all applicable taxes and costs, the sum of **SEVEN HUNDRED FIFTY-FOUR THOUSAND, ONE HUNDRED TWENTY-FIVE DOLLARS AND NO CENTS (\$754,125.00)**. Payment shall be made as set forth in the General Conditions.

**D. LIQUIDATED DAMAGES.** In accordance with Government Code section 53069.85, it is agreed that the Contractor will pay the City the sum set forth in Special Conditions, Article 1.11 for each and every calendar day of delay beyond the time prescribed in the Contract Documents for finishing the Work, as Liquidated Damages and not as a penalty or forfeiture. In the event this is not paid, the Contractor agrees the City may deduct that amount from any money due or that may become due the Contractor under the Contract. This Article does not exclude recovery of other damages specified in the Contract Documents.

**E. COMPONENT PARTS OF THE CONTRACT.** The "Contract Documents" include the following:

- Notice Inviting Bids
- Instructions to Bidders
- Bid Form
- Bid Bond
- Designation of Subcontractors
- Information Required of Bidders
- Non-Collusion Declaration Form
- Iran Contracting Act Certification
- Public Works Contractor Registration Certification
- Performance Bond

Payment (Labor and Materials) Bond  
General Conditions  
Special Conditions  
Technical Specifications  
Addenda  
Plans and Drawings  
Standard Specifications for Public Works Construction "Greenbook", latest edition, Except  
Sections 1-9  
Applicable Local Agency Standards and Specifications, as last revised  
Approved and fully executed change orders  
Any other documents contained in or incorporated into the Contract

The Contractor shall complete the Work in strict accordance with all of the Contract Documents.

All of the Contract Documents are intended to be complementary. Work required by one of the Contract Documents and not by others shall be done as if required by all. This Contract shall supersede any prior agreement of the parties.

**F. PROVISIONS REQUIRED BY LAW AND CONTRACTOR COMPLIANCE.** Each and every provision of law required to be included in these Contract Documents shall be deemed to be included in these Contract Documents. The Contractor shall comply with all requirements of applicable federal, state and local laws, rules and regulations, including, but not limited to, the provisions of the California Labor Code and California Public Contract Code which are applicable to this Work.

**G. INDEMNIFICATION.** Contractor shall provide indemnification and defense as set forth in the General Conditions.

**H. PREVAILING WAGES.** Contractor shall be required to pay the prevailing rate of wages in accordance with the Labor Code which such rates shall be made available at the City's Administrative Office or may be obtained online at [dir.ca.gov](http://dir.ca.gov) and which must be posted at the job site.

**[REMAINDER OF PAGE LEFT INTENTIONALLY BLANK]**

IN WITNESS WHEREOF, this Contract has been duly executed by the above-named parties, on the day and year above written.

**CITY OF ARCADIA**

**MISSION PAVING AND SEALING, INC.**

By: \_\_\_\_\_  
Dominic Lazzaretto  
City Manager

By: \_\_\_\_\_  
Signature  
\_\_\_\_\_  
Print Name and Title

*Attest:*

By: \_\_\_\_\_  
City Clerk

By: \_\_\_\_\_  
Signature  
\_\_\_\_\_  
Print Name and Title

*Approved as to Form:*

\_\_\_\_\_  
Michael J. Maurer  
City Attorney

**(CONTRACTOR'S SIGNATURE MUST BE NOTARIZED AND CORPORATE SEAL AFFIXED)**

## Notary Acknowledgment

A notary public or other officer completing this certificate verifies only the identity of the individual who signed the document to which this certificate is attached, and not the truthfulness, accuracy, or validity of that document.

STATE OF CALIFORNIA  
 COUNTY OF \_\_\_\_\_

On \_\_\_\_\_, 20\_\_\_, before me, \_\_\_\_\_, Notary Public, personally appeared \_\_\_\_\_, who proved to me on the basis of satisfactory

evidence to be the person(s) whose name(s) is/are subscribed to the within instrument and acknowledged to me that he/she/they executed the same in his/her/their authorized capacity(ies), and that by his/her/their signature(s) on the instrument the person(s), or the entity upon behalf of which the person(s) acted, executed the instrument.

I certify under PENALTY OF PERJURY under the laws of the State of California that the foregoing paragraph is true and correct.

WITNESS my hand and official seal.

Signature of Notary Public \_\_\_\_\_

### OPTIONAL

*Though the information below is not required by law, it may prove valuable to persons relying on the document and could prevent fraudulent removal and reattachment of this form to another document.*

#### CAPACITY CLAIMED BY SIGNER

#### DESCRIPTION OF ATTACHED DOCUMENT

- Individual
- Corporate Officer

\_\_\_\_\_ Title(s)

\_\_\_\_\_ Title or Type of Document

- Partner(s)  Limited
- Attorney-In-Fact  General

\_\_\_\_\_ Number of Pages

- Trustee(s)
- Guardian/Conservator
- Other:

\_\_\_\_\_ Date of Document

Signer is representing:  
 Name Of Person(s) Or Entity(ies)

\_\_\_\_\_  
 \_\_\_\_\_

\_\_\_\_\_ Signer(s) Other Than Named Above

## Notary Acknowledgment

A notary public or other officer completing this certificate verifies only the identity of the individual who signed the document to which this certificate is attached, and not the truthfulness, accuracy, or validity of that document.

STATE OF CALIFORNIA  
 COUNTY OF \_\_\_\_\_

On \_\_\_\_\_, 20\_\_\_, before me, \_\_\_\_\_, Notary Public, personally appeared \_\_\_\_\_, who proved to me on the basis of satisfactory

evidence to be the person(s) whose name(s) is/are subscribed to the within instrument and acknowledged to me that he/she/they executed the same in his/her/their authorized capacity(ies), and that by his/her/their signature(s) on the instrument the person(s), or the entity upon behalf of which the person(s) acted, executed the instrument.

I certify under PENALTY OF PERJURY under the laws of the State of California that the foregoing paragraph is true and correct.

WITNESS my hand and official seal.

Signature of Notary Public \_\_\_\_\_

### OPTIONAL

*Though the information below is not required by law, it may prove valuable to persons relying on the document and could prevent fraudulent removal and reattachment of this form to another document.*

#### CAPACITY CLAIMED BY SIGNER

#### DESCRIPTION OF ATTACHED DOCUMENT

- Individual
- Corporate Officer

\_\_\_\_\_ Title(s)

\_\_\_\_\_ Title or Type of Document

- Partner(s)  Limited
- Attorney-In-Fact  General

\_\_\_\_\_ Number of Pages

- Trustee(s)
- Guardian/Conservator
- Other:

\_\_\_\_\_ Date of Document

Signer is representing:  
 Name Of Person(s) Or Entity(ies)

\_\_\_\_\_  
 \_\_\_\_\_

\_\_\_\_\_ Signer(s) Other Than Named Above

**DATE:** June 16, 2026

**TO:** Honorable Mayor and City Council

**FROM:** Paul Cranmer, Public Works Services Director  
By: Tiffany Lee, Interim Principal Civil Engineer

**SUBJECT:** DESIGN-BUILD CONTRACT WITH PACIFIC HYDROTECH CORPORATION FOR THE PECK WELL PFAS TREATMENT SYSTEM PROJECT IN THE AMOUNT OF \$3,204,400  
**CEQA: Exempt**  
**Recommendation: Approve**

### **SUMMARY**

The Fiscal Year 2024-25 Capital Improvement Program (“CIP”) Budget provides for the design and construction of a treatment system to address Per-and Polyfluoroalkyl Substances (“PFAS”) at Peck Well. To ensure the City is receiving the highest quality of service and most competitive pricing for the design-build services, the Public Works Services Department (“PWSD”) conducted a Request for Proposals (“RFP”). Based on the evaluated proposal, interview, and financial evaluation, it was determined that Pacific Hydrotech Corporation is a qualified and responsible firm to provide professional design-build services for the design and construction of the Peck Well PFAS Treatment System.

It is recommended that the City Council approve, authorize, and direct the City Manager to execute a design-build contract with Pacific Hydrotech Corporation for the Peck Well PFAS Treatment System Project in the amount of \$3,204,400, with a 10% contingency.

### **BACKGROUND**

The US Environmental Protection Agency (“EPA”) describes PFAS as a group of man-made chemicals manufactured and used in a variety of industries. PFAS can be found

in products such as food packaging as well as commercial and household products, which often end up in groundwater. These chemicals are toxic at relatively low concentrations, presenting a danger to both human health and the environment. On April 10, 2024, the EPA established legally enforceable Maximum Contaminant Levels (“MCLs”) for PFAS contaminants in drinking water. Public water systems are required to monitor the PFAS MCLs and conduct ongoing compliance monitoring. If monitoring shows that drinking water levels exceed these MCLs, public water systems must implement solutions that reduce PFAS by 2029.

The PWSD regularly tests the drinking water from the supply wells to ensure its safety. Recent water quality sampling indicated that Peck Well had a PFAS level of 9.1 parts per trillion (“ppt”), which exceeded the Notification Level of 6.5 ppt. Peck Well was drilled in 1962 and has a pump capacity of approximately 3,600 gallons per minute. Peck Well is crucial to the City's water system because it supplies over 40% of the groundwater to Zone 4. Construction of a treatment system for Peck Well is urgent to prevent Peck Well from being shut down. To address the issue, funding for the design and construction of a water treatment system to treat PFAS at Peck Well was included in the FY 2024-25 Capital Improvement Program.

To minimize costs and address the long lead-time for procuring the Ion Exchange (“IX”) Adsorption Systems, PWSD staff elected to purchase the IX adsorption treatment system separately and supply it to a contractor for installation under a separate contract. On December 2, 2025, the City Council approved a Professional Services Agreement with AqueoUSVETS LLC. for the purchase of IX adsorption treatment vessels. The next phase of this project will include the design and installation of the piping, valves, fittings, backwash tank, and concrete foundation pads. The contractor will also install the treatment vessels. As part of this contract, pavement improvements will be included and a 35-foot-wide automatic slide gate will be installed at the well site.

## **DISCUSSION**

On April 13, 2026, a Notice Inviting Proposals for the Design-Build of the Peck Well PFAS Treatment System Project was published in accordance with City Council Resolution No. 7483, and proposal packages were distributed to firms that provide design-build services. One proposal was received on May 12, 2026.

<b>Rank</b>	<b>Company Name</b>	<b>Score</b>	<b>Cost</b>
1	Pacific Hydrotech Corporation	93.34%	\$ 3,204,400 *

\*The vendor's original proposal fee was \$3,304,400, City staff negotiated with them to reduce the cost.

Staff contacted the companies that received proposal packages to inquire why they did not submit a proposal. The firms indicated that they chose not to pursue the project due to the requested timeframe and the contractual risk inherent to a design build project. Design-Build is a construction delivery method that provides a single point of contact for both the design and construction phases of a project. One entity holds single-source responsibility and contractual risk for every aspect of the project. Due to the nature of the process and the expertise in the type of work needed, there are not many firms that can complete this work.

The one proposal received was evaluated based on the proposer's qualifications, performance history, technical approach, understanding of the City's needs, proposal cost, and design-build timeline. After careful review and consideration, it was determined that Pacific Hydrotech is suited for the Peck Well PFAS Treatment System Project based on their detailed proposal and demonstrated history with similar projects. Pacific Hydrotech Corporation has successfully completed comparable projects for the City of Arcadia (Live Oak Well TCE Treatment System), Monte Vista Water District, City of Needles, California American Water Company, Santa Clarita Valley Water Agency, Orange County Water District, and Golden State Water Company.

Pacific Hydrotech Corporation's original proposal fee was \$3,304,400. Having determined that Pacific Hydrotech Corporation is the most qualified firm to complete the project, City staff negotiated with them to reduce the cost while ensuring the full scope of services would still be met.

## **ENVIRONMENTAL ANALYSIS**

This project is categorically exempt as a Class 3, defined in Section 15303(d) of the California Environmental Quality Act ("CEQA"), which exempts projects consisting of the construction of new, small structures related to utility extensions. The addition of an IX treatment system to an existing potable water supply well qualifies for this exemption. A Notice of Exemption has been filed with the County of Los Angeles and the State Clearinghouse.

## **FISCAL IMPACT**

Funds in the amount of \$8,700,000 have been budgeted in the FY 2024-25 Capital Improvement Program for the PFAS Treatment System at Peck Well. Funding for this project is sourced from several PFAS litigation settlements the City has received. On December 2, 2025, the City Council approved a Professional Services Agreement with AqueoUSVETS LLC. for the purchase of IX adsorption treatment vessels in the amount of \$1,825,103.30, leaving \$6,874,896.70 available for the design and construction phase of the project. The total cost for the design and construction of the Peck Well PFAS Treatment System Project is \$3,204,400. With the requested 10% contingency, the project cost is \$3,524,840, which is within the adopted budget.

## **RECOMMENDATION**

It is recommended that the City Council determine that this project is categorically exempt under the California Environmental Quality Act ("CEQA"); and approve, authorize, and direct the City Manager to execute a design-build contract with Pacific Hydrotech Corporation for the Peck Well PFAS Treatment System Project in the amount of \$3,204,400, with a 10% contingency.

Approved:



Dominic Lazzaretto  
City Manager

Attachment: Proposed Design-Build Contract

**DESIGN BUILD CONTRACT  
BETWEEN  
CITY OF ARCADIA  
AND  
PACIFIC HYDROTECH CORPORATION**

This Design-Build Contract (“Contract”) is made and entered into this \_\_\_\_ day of \_\_\_\_\_, 2026, by and between the by and between the **CITY OF ARCADIA (“City”)** and **PACIFIC HYDROTECH CORPORATION** (the “Design-Build Entity”), for the purpose of designing and constructing the **Peck Well Ion Exchange Adsorption Treatment System Project** (the “Project”). The City and the Design-Build Entity are herein collectively referred to as the “Parties.”

**RECITALS**

A. The City desires to contract with a single entity for design and construction of the Project, as set forth in this Contract.

B. The Design-Build Entity was invited to respond to the City’s Request for Proposal (“RFP”) for the Project.

C. The Design-Build Entity submitted a Proposal for the Project, which was selected as providing the best-value for the Project, and is prepared to enter into this Contract.

**AGREEMENT**

In consideration of the above recitals and the mutual covenants and conditions set forth herein, and for good and valuable consideration, the receipt and sufficiency of which are hereby acknowledged, the Parties hereby set forth their mutual covenants and understandings as follows:

**1. Incorporation of Recitals.** The above referenced recitals are true and correct and are incorporated into this Contract by this reference.

**2. Design-Build Entity.** The Design-Build Entity consists of **N2W Engineering** functioning as the designer/design team for the Project and providing **civil structural engineering services**, **Superior Tank** functioning as the subcontractor team for the Project and providing furnishing and installation of **backwash tank services**, **Reliance Paving** functioning as the subcontractor team for the Project and providing **asphalt paving services**, and **Hemet Fence** functioning as the subcontractor team for the Project and providing the furnishing and installation of the perimeter entry gate to the project facility site, and **Pacific Hydrotech Corporation** as the general contractor for the project and providing all construction services for the Project. For purposes of this Contract, a properly authorized representative of Design-Build Entity shall execute the Contract on its behalf, and shall have the full authority to make all decisions necessary on behalf of the Design-Build Entity Notwithstanding the foregoing, the City may accept bonds provided from the member of the

Design-Build Entity designated for construction services, and/or professional liability insurance from the member of the Design-Build Entity designated for design/architectural services.

**3. Incorporation of Documents.**

3.1 This Contract includes and hereby incorporates in full by reference the following Contract Documents, including all exhibits, drawings, specifications and documents therein, and attachments and addenda thereto:

- Request for Proposal (“RFP”) and all exhibits, addenda, attachments and appendices
- Design-Build Entity Proposal in response to RFP dated **April 2026**
- Contract
- General Conditions
- Attachment 1 to this Contract - Cost of Extra Work
- Attachment 2 to this Contract - Performance Bond
- Attachment 3 to this Contract - Payment Bond
- Attachment 4 to this Contract - Workers Compensation Certification
- Attachment 5 to this Contract - Public Works Contractor Registration Certification

3.2 **Acknowledgement of Contract Documents.** The above documents constitute and may hereinafter be referred to as the “Contract Documents.” In addition to signing this Contract, the Design-Build Entity shall review and execute where appropriate all the Attachments to this Contract described above. Also, the Design-Build Entity shall initial this paragraph immediately below acknowledging that he or she has read, understood and agrees with all of the terms of the Contract Documents, including, but not limited to, provisions of the General Conditions relating to indemnification, insurance, standards of performance, termination, compensation and time of the essence performance. The Design-Build Entity shall not disclaim knowledge of the meaning and effect of any term or provision of the Contract Documents, and agrees to strictly abide by their meaning and intent. In the event that the Design-Build Entity fails to initial below, the City shall have the right to declare the Contract unexecuted and to award the Contract to another the Design-Build Entity in accordance with California law.

---

Design-Build Entity’s Initials

#### **4. The Design-Build Entity's Obligations.**

4.1 Guaranteed Maximum Price. The Design-Build Entity promises and agrees, at its own cost and expense, to furnish to the City all labor, materials, tools, equipment, services, and incidental and customary work necessary to fully and adequately complete the Project as described in the Contract Documents (hereinafter the "Scope of Work"), **for a Guaranteed Maximum Price ("GMP") of THREE MILLION, TWO HUNDRED FOUR THOUSAND, FOUR HUNDRED DOLLARS AND NO CENTS (\$3,204,400.00)** as stated in the Design-Build Entity's Proposal submitted in response to the RFP. Unless otherwise stated in the Contract Documents, the GMP shall pay for all costs and expenses required to design and construct the Project.

4.2 Extra Work. Extra Work shall have the meaning given to it in the General Conditions. Extra Work shall be compensated at the rates set forth in Attachment 1 to this Contract, and shall be initiated only upon written approval by the City as described in the General Conditions.

4.3 Standard of Performance. The Design-Build Entity's performance of the work set forth in the Contract Documents shall at all times be performed in a skillful and competent manner, consistent with the standards generally recognized as being employed by professionals in the same discipline(s) in the State of California, and Design-Build Entity shall be fully responsible to City for any damages or delays to the Project caused by the Design-Build Entity as specified in the indemnification provision of this Contract. The Design-Build Entity's performance shall at all times be in conformance with the standards set forth in the Contract and the General Conditions.

#### **5. Period of Performance, Liquidated Damages, and Performance Incentive.**

5.1 The Design-Build Entity guarantees that it shall perform and complete all work necessary for Completion of the Project, as defined in the General Conditions, by the **Guaranteed Completion Date of April 30, 2027 ("GCD")**.

5.2 The Design-Build Entity agrees that liquidated damages will apply in the amount of **\$2,500 for each and every calendar day** beyond the GCD that Final Completion of the Project has not been achieved.

**6. The City's Basic Obligation.** The City agrees to engage and do hereby engage the Design-Build Entity as an independent contractor to furnish all materials and to perform all work described in the Scope of Work for the Project according to the terms and conditions herein contained for the GMP set forth above. Except as otherwise provided in the Contract, the City shall pay to the Design-Build Entity, as full consideration for the satisfactory performance by the Design-Build Entity of the services and obligations required by this Contract, the above referenced compensation in accordance with compensation provisions set forth in the Contract.

## 7. Representatives.

7.1 City's Representative. The City hereby designates **Tiffany Lee, Interim Principal Civil Engineer**, as the person to act as its representative for the performance of this Contract ("City's Representative"). The City's Representative shall be authorized to act as liaison between City and the Design-Build Entity in the administration of this Contract and all work on the Project. The City's Representative shall have the power to act on behalf of the City for all purposes under this Contract. City may designate new and/or different individuals to act as City's Representative from time to time upon written notice to the Design-Build Entity.

7.2 Design-Build Entity's Representative. The Design-Build Entity hereby designates **Joselito Guintu, Vice-President**, or his or her designee, to act as its representative for the performance of this Contract ("Design-Build Entity's Representative"). Design-Build Entity's Representative shall have full authority to represent and act on behalf of the Design-Build Entity for all purposes under this Contract. The Design-Build Entity's Representative shall supervise and direct all work on the Project, using his best skill and attention, and shall be responsible for all means, methods, techniques, sequences and procedures and for the satisfactory coordination of all portions of the work pursuant to this Contract.

8. Design-Build Entity's Licensing. The Design-Build Entity shall have only appropriately licensed contractors performing work on the Project as required by the Business and Professions Code. The Design-Build Entity hereby designates **Pacific Hydrotech Corporation, License No. Class A, B, and Hazard Substance Removal**, (License No. 518355) to act as the licensed general contractor for the Project. Design-Build Entity's general contractor shall perform all services required under the Contract Documents in a skillful and competent manner, consistent with the standards generally recognized as being employed by professionals qualified to perform such services in the same discipline in the State of California, and the Design Build entity shall be fully responsible to the City for any damages and/or delays to the Project as specified in the indemnification provisions of the Contract. Any change in the general contractor shall be subject to the City's prior written approval, which approval shall not be unreasonably withheld. The new general contractor shall be of at least equal competence as the prior general contractor. In the event that City and Design-Build Entity cannot agree as to the substitution of a new general contractor, the City shall be entitled to terminate this Contract as described in the General Conditions.

9. Design-Build Entity's Design Professional of Record. The Design-Build Entity shall name a specific person to act as the Design Professional of Record as described in the General Conditions, subject to the approval of the City. The Design-Build Entity hereby designates **Jang Wang, P.E. (License No. 81123)** to act as the Design Professional of Record for the Project. Design-Build Entity's Design Professional of Record shall perform all services required under the Contract Documents in a skillful and competent manner,

consistent with the standards generally recognized as being employed by professionals qualified to perform such services in the same discipline in the State of California, and the Design Build entity shall be fully responsible to the City for any damages and/or delays to the Project as specified in the indemnification provisions of the Contract. Any change in the Design Professional of Record shall be subject to the City's prior written approval, which approval shall not be unreasonably withheld. The new Design Professional of Record shall be of at least equal competence as the prior Design Professional of Record. In the event that City and Design-Build Entity cannot agree as to the substitution of a new Design Professional of Record, the City shall be entitled to terminate this Contract as described in the General Conditions.

**10. Indemnification.** To the fullest extent allowed by law, Design-Build Entity agrees to protect, save, defend and hold harmless, to the greatest extent provided by law, the City, its governing council and each member thereof, their officers, agents and employees from any and all claims, liabilities, reasonable expenses or damages of any nature, including reasonable attorney's fees, for injury or death of any person, or damage to property, or interference with the use of property arising out of the negligent acts, errors or omission, or willful misconduct by the Design-Build Entity, the Design-Build Entity's agents, officers, employees, sub-consultants, or independent consultants hired by the Design-Build Entity to provide services pursuant to this Contract. The only exception to the Design-Build Entity's responsibility to protect, save, defend and hold harmless the City, is where a claim, liability, expense or damage occurs due to the sole negligence, willful misconduct or active negligence of the City. This hold harmless provision shall apply to all liability, as provided for above, regardless of whether any insurance policies are applicable. Insurance policy limits do not act as a limitation upon the amount of the indemnification to be provided by the Design-Build Entity. Notwithstanding the foregoing, to the extent Design-Build Entity's Scope of Work is subject to Civil Code Section 2782.8, the above indemnity shall be limited, to the extent required by Civil Code Section 2782.8, to claims that arise out of, pertain to, or relate to the negligence, recklessness, or willful misconduct of the Design-Build Entity. Notwithstanding the foregoing, to the extent required by Civil Code section 2782, Design-Build Entity's indemnity obligation shall not apply to liability for damages for death or bodily injury to persons, injury to property, or any other loss, damage or expense arising from the sole or active negligence or willful misconduct of the City.

In claims against any person or entity indemnified under this provision, that are made by an employee of the Design-Build Entity or any Subcontractor, a person indirectly employed by the Design-Build Entity or any Subcontractor, or anyone for whose acts the Design-Build Entity or any Subcontractor may be liable, the indemnification obligation under this provision shall not be limited by any limitation on amount or type of damages, compensation, or benefits payable by or for Design-Build Entity or any Subcontractor under workers' compensation acts, disability benefit acts, or other employee benefit acts or any other insurance limitations. The indemnification obligations under this provision shall not be limited by any assertion or finding that the person or entity indemnified is liable by reason of a non-delegable duty.

Joint and Several Liability shall apply to the Design-Build Entity. In the event the Design-Build Entity and one or more than one other party is connected with an accident or occurrence covered by this indemnification, then all such parties shall be jointly and severally responsible to each of the Indemnitees for indemnification, and the ultimate responsibility among such indemnifying parties for the loss and expense of any such indemnification shall be resolved without jeopardy to any indemnitee listed herein.

**11. The Design-Build Entity's Labor Certification.** The Design-Build Entity maintains that it is aware of the provisions of Section 3700 of the California Labor Code which require every employer to be insured against liability for Worker's Compensation or to undertake self-insurance in accordance with the provisions of that Code, and agrees to comply with such provisions before commencing the performance of all work described in the Scope of Work for the Project. A certification form for this purpose is Attachment 4 to this Contract and incorporated herein by reference, and shall be executed simultaneously with this Contract.

**12. Contractor and Subcontractor Registration.** Pursuant to Labor Code sections 1725.5 and 1771.1, all contractors and subcontractors that wish to bid on, be listed in a bid proposal, or enter into a contract to perform public work must be registered with the Department of Industrial Relations. No bid will be accepted nor any contract entered into without proof of the contractor's and subcontractors' current registration with the Department of Industrial Relations to perform public work. Design-Build Entity is directed to review, fill out and execute the Public Works Contractor Registration Certification attached hereto as Attachment "5" prior to contract execution.

**13. Successors.** The parties do for themselves, their heirs, executors, administrators, successors, and assigns agree to the full performance of all of the provisions contained in this Contract. The Design-Build Entity may not either voluntarily or by action of law, assign any obligation assumed by the Design-Build Entity hereunder without the prior written consent of the City.

**14. Notices.** All notices hereunder and communications regarding interpretation of the terms of the Contract or changes thereto shall be provided by the mailing thereof by registered or certified mail, return receipt requested, postage prepaid and addressed as follows:

*To City:*  
City of Arcadia  
11800 Goldring Road  
P.O. Box 60021  
Arcadia, CA 91066-6021  
Attn: Tiffany Lee, Interim Principal  
Civil Engineer

*To Design-Build Entity:*  
Pacific Hydrotech Corporation  
30590 Cochise Circle  
Murrieta, CA 92563  
Attn: Joselito Guintu, Vice-President

Any notice so given shall be considered received by the other party three (3) days after

deposit in the U.S. Mail, first class postage prepaid, addressed to the party at the above address. Actual notice shall be deemed adequate notice on the date actual notice occurred, regardless of the method of service.

**15. Attachments.** All Attachments referenced in this Contract are incorporated into the Contract by this reference.

**16. Amendments, Changes and Modifications.** This Contract may not be amended, changed, modified, altered or terminated without the written agreement of both Parties hereto.

**17. Execution in Counterparts.** This Contract may be executed in several counterparts, each of which shall be an original and all of which shall constitute but one and the same instrument.

**18. Applicable Law.** This Contract shall be governed by and construed in accordance with the laws of the State of California, and venue in the County of Los Angeles.

**19. Captions.** The captions or headings in this Contract are for convenience only and in no way define, limit or describe the scope or intent of any provisions or Sections of this Contract.

**20. Prior Agreements.** This Contract contains all of the agreements of the Parties hereto with respect to any matter covered or mentioned in this Contract and no prior agreements or understanding pertaining to any such matter shall be effective for any purpose.

**21. Further Assurances.** Parties shall promptly execute and deliver all documents and instruments reasonably requested to give effect to the provisions of this Contract.

**22. Recitals Incorporated.** The Recitals set forth at the beginning of this Contract are hereby incorporated into its terms and provisions by this reference.

**23. Time of the Essence.** Time is of the essence with respect to each of the terms, covenants, and conditions of this Contract.

**24. Authority of Signatories.** The persons executing this Contract on behalf of their respective Parties represent and warrant that they have the authority to do so under law and from their respective Parties.

**IN WITNESS WHEREOF**, the Parties have caused this Contract to be executed by their respective officers who are duly authorized, as of the Effective Date set forth above.

***SIGNATURES ON NEXT PAGE***

**IN WITNESS WHEREOF**, the Parties have caused this Contract to be executed by their respective officers who are duly authorized, as of the Effective Date set forth above.

**CITY OF ARCADIA**

**PACIFIC HYDROTECH CORPORATION**

\_\_\_\_\_  
Dominic Lazzaretto  
City Manager

Attest:

\_\_\_\_\_  
City Clerk

APPROVED AS TO FORM:

\_\_\_\_\_  
Michael J. Mauer  
City Attorney

\_\_\_\_\_  
Signature

\_\_\_\_\_  
Print Name

\_\_\_\_\_  
Title

\_\_\_\_\_  
Signature

\_\_\_\_\_  
Print Name

\_\_\_\_\_  
Title

DRAFT

**ATTACHMENT 1**

**HOURLY RATE SCHEDULE FOR EXTRA WORK**

NOT APPLICABLE.

**ATTACHMENT 2**

**PERFORMANCE BOND**

KNOW ALL PERSONS BY THESE PRESENTS:

THAT WHEREAS, the City of Arcadia, (hereinafter referred to as “City”) has awarded to **Pacific Hydrotech Corporation**, (hereinafter referred to as the “Contractor”) an agreement for **Peck Well Ion Exchange (IX) Adsorption Treatment System Project, Contract No. \_\_\_\_\_** (hereinafter referred to as the “Project”).

WHEREAS, the work to be performed by the Contractor is more particularly set forth in the Contract Documents for the Project dated \_\_\_\_\_, (hereinafter referred to as “Contract Documents”), the terms and conditions of which are expressly incorporated herein by reference; and

WHEREAS, the Contractor is required by said Contract Documents to perform the terms thereof and to furnish a bond for the faithful performance of said Contract Documents.

NOW, THEREFORE, we, \_\_\_\_\_, the undersigned Contractor and \_\_\_\_\_ as Surety, a corporation organized and duly authorized to transact business under the laws of the State of California, are held and firmly bound unto the City in the sum of **THREE MILLION, TWO HUNDRED FOUR THOUSAND, FOUR HUNDRED DOLLARS AND NO CENTS (\$3,204,400.00)**, said sum being not less than one hundred percent (100%) of the total amount of the Contract, for which amount well and truly to be made, we bind ourselves, our heirs, executors and administrators, successors and assigns, jointly and severally, firmly by these presents.

THE CONDITION OF THIS OBLIGATION IS SUCH, that, if the Contractor, his or its heirs, executors, administrators, successors or assigns, shall in all things stand to and abide by, and well and truly keep and perform the covenants, conditions and agreements in the Contract Documents and any alteration thereof made as therein provided, on its part, to be kept and performed at the time and in the manner therein specified, and in all respects according to their intent and meaning; and shall faithfully fulfill all obligations including the one (1) year guarantee of all materials and workmanship; and shall indemnify and save harmless the City, its officials, officers, employees, and authorized volunteers, as stipulated in said Contract Documents, then this obligation shall become null and void; otherwise it shall be and remain in full force and effect.

As a part of the obligation secured hereby and in addition to the face amount specified therefore, there shall be included costs and reasonable expenses and fees including reasonable attorney’s fees, incurred by City in enforcing such obligation.

As a condition precedent to the satisfactory completion of the Contract Documents, unless otherwise provided for in the Contract Documents, the above obligation shall hold good for a period of one (1) year after the acceptance of the work by City, during which time if Contractor shall fail to make full, complete, and satisfactory repair and replacements and totally protect the City from loss or damage resulting from or caused by defective materials or faulty workmanship. The obligations of Surety hereunder shall continue so long as any obligation of Contractor remains. Nothing herein shall limit the City's rights or the Contractor or Surety's obligations under the Contract, law or equity, including, but not limited to, California Code of Civil Procedure Section 337.15.

Whenever Contractor shall be, and is declared by the City to be, in default under the Contract Documents, the Surety shall remedy the default pursuant to the Contract Documents, or shall promptly, at the City's option:

- (1) Take over and complete the Project in accordance with all terms and conditions in the Contract Documents; or
- (2) Obtain a bid or bids for completing the Project in accordance with all terms and conditions in the Contract Documents and upon determination by Surety of the lowest responsive and responsible bidder, arrange for a Contract between such bidder, the Surety and the City, and make available as work progresses sufficient funds to pay the cost of completion of the Project, less the balance of the contract price, including other costs and damages for which Surety may be liable. The term "balance of the contract price" as used in this paragraph shall mean the total amount payable to Contractor by the City under the Contract and any modification thereto, less any amount previously paid by the City to the Contractor and any other set offs pursuant to the Contract Documents.
- (3) Permit the City to complete the Project in any manner consistent with California law and make available as work progresses sufficient funds to pay the cost of completion of the Project, less the balance of the contract price, including other costs and damages for which Surety may be liable. The term "balance of the contract price" as used in this paragraph shall mean the total amount payable to Contractor by the City under the Contract and any modification thereto, less any amount previously paid by the City to the Contractor and any other set offs pursuant to the Contract Documents.

Surety expressly agrees that the City may reject any contractor or subcontractor which may be proposed by Surety in fulfillment of its obligations in the event of default by the Contractor.

Surety shall not utilize Contractor in completing the Project nor shall Surety accept a bid from Contractor for completion of the Project if the City, when declaring the Contractor in

default, notifies Surety of the City's objection to Contractor's further participation in the completion of the Project.

The Surety, for value received, hereby stipulates and agrees that no change, extension of time, alteration or addition to the terms of the Contract Documents or to the Project to be performed thereunder shall in any way affect its obligations on this bond, and it does hereby waive notice of any such change, extension of time, alteration or addition to the terms of the Contract Documents or to the Project.

By their signatures hereunder, Surety and Contractor hereby confirm under penalty of perjury that surety is an admitted surety insurer authorized to do business in the State of California.

**[REMAINDER OF PAGE LEFT INTENTIONALLY BLANK]**

IN WITNESS WHEREOF, we have hereunto set our hands and seals this \_\_\_\_\_ day of \_\_\_\_\_, 20\_\_.

(Corporate Seal)

\_\_\_\_\_  
Contractor/ Principal

By \_\_\_\_\_

Title \_\_\_\_\_

(Corporate Seal)

\_\_\_\_\_  
Surety

By \_\_\_\_\_

Attorney-in-Fact

(Attach Attorney-in-Fact Certificate)

Title \_\_\_\_\_

The rate of premium on this bond is \_\_\_\_\_ per thousand. The total amount of premium charges is \$\_\_\_\_\_.

(The above must be filled in by corporate attorney.)

THIS IS A REQUIRED FORM

Any claims under this bond may be addressed to:

(Name and Address of Surety)

\_\_\_\_\_  
\_\_\_\_\_  
\_\_\_\_\_

(Name and Address of Agent or Representative for service of process in California, if different from above)

\_\_\_\_\_  
\_\_\_\_\_  
\_\_\_\_\_

(Telephone number of Surety and Agent or Representative for service of process in California)

\_\_\_\_\_

**ATTACHMENT 3**

**PAYMENT BOND**

KNOW ALL MEN BY THESE PRESENTS That

WHEREAS, the City of Arcadia (hereinafter designated as the “City”), by action taken or a resolution passed **June 16, 2026**, has awarded to **Pacific Hydrotech Corporation** hereinafter designated as the “Principal,” a contract for the work described as follows: **Peck Well Ion Exchange (IX) Adsorption Treatment System Project, Contract No. \_\_\_\_\_** (the “Project”); and

WHEREAS, said Principal is required to furnish a bond in connection with said contract; providing that if said Principal or any of its Subcontractors shall fail to pay for any materials, provisions, provender, equipment, or other supplies used in, upon, for or about the performance of the work contracted to be done, or for any work or labor done thereon of any kind, or for amounts due under the Unemployment Insurance Code or for any amounts required to be deducted, withheld, and paid over to the Employment Development Department from the wages of employees of said Principal and its Subcontractors with respect to such work or labor the Surety on this bond will pay for the same to the extent hereinafter set forth.

NOW THEREFORE, we, the Principal and \_\_\_\_\_ as Surety, are held and firmly bound unto the City in the penal sum of **THREE MILLION, TWO HUNDRED FOUR THOUSAND, FOUR HUNDRED DOLLARS AND NO CENTS (\$3,204,400.00)** lawful money of the United States of America, for the payment of which sum well and truly to be made, we bind ourselves, our heirs, executors, administrators, successors and assigns, jointly and severally, firmly by these presents.

THE CONDITION OF THIS OBLIGATION IS SUCH that if said Principal, his or its subcontractors, heirs, executors, administrators, successors or assigns, shall fail to pay any of the persons named in Civil Code Section 9100, fail to pay for any materials, provisions or other supplies, used in, upon, for or about the performance of the work contracted to be done, or for any work or labor thereon of any kind, or amounts due under the Unemployment Insurance Code with respect to work or labor performed under the contract, or for any amounts required to be deducted, withheld, and paid over to the Employment Development Department or Franchise Tax Board from the wages of employees of the contractor and his subcontractors pursuant to Revenue and Taxation Code Section 18663, with respect to such work and labor the Surety or Sureties will pay for the same, in an amount not exceeding the sum herein above specified, and also, in case suit is brought upon this bond, all litigation expenses incurred by the City in such suit, including reasonable attorneys’ fees, court costs, expert witness fees and investigation expenses.

This bond shall inure to the benefit of any of the persons named in Civil Code Section 9100 so as to give a right of action to such persons or their assigns in any suit brought upon this bond.

It is further stipulated and agreed that the Surety on this bond shall not be exonerated or released from the obligation of this bond by any change, extension of time for performance, addition, alteration or modification in, to, or of any contract, plans, specifications, or agreement pertaining or relating to any scheme or work of improvement herein above described, or pertaining or relating to the furnishing of labor, materials, or equipment therefore, nor by any change or modification of any terms of payment or extension of the time for any payment pertaining or relating to any scheme or work of improvement herein above described, nor by any rescission or attempted rescission or attempted rescission of the contract, agreement or bond, nor by any conditions precedent or subsequent in the bond attempting to limit the right of recovery of claimants otherwise entitled to recover under any such contract or agreement or under the bond, nor by any fraud practiced by any person other than the claimant seeking to recover on the bond and that this bond be construed most strongly against the Surety and in favor of all persons for whose benefit such bond is given, and under no circumstances shall Surety be released from liability to those for whose benefit such bond has been given, by reason of any breach of contract between the owner or City and original contractor or on the part of any obligee named in such bond, but the sole conditions of recovery shall be that claimant is a person described in Civil Code Section 9100, and has not been paid the full amount of his claim and that Surety does hereby waive notice of any such change, extension of time, addition, alteration or modification herein mentioned, including but not limited to the provisions of sections 2819 and 2845 of the California Civil Code.

By their signatures hereunder, Surety and Principal hereby confirm under penalty of perjury that surety is an admitted surety insurer authorized to do business in the State of California.

IN WITNESS WHEREOF, we have hereunto set our hands and seals this \_\_\_\_\_ day of \_\_\_\_\_, 20\_\_.

(Corporate Seal)

\_\_\_\_\_  
Contractor/ Principal

By \_\_\_\_\_

Title \_\_\_\_\_

(Corporate Seal)

\_\_\_\_\_  
Surety

By \_\_\_\_\_  
Attorney-in-Fact

(Attach Attorney-in-Fact Certificate)

Title \_\_\_\_\_

**ATTACHMENT 4**

**WORKERS COMPENSATION CERTIFICATION**

Labor Code section 3700 in relevant part provides:

Every employer except the State shall secure the payment of compensation in one or more of the following ways:

(a) By being insured against liability to pay compensation in one or more insurers duly authorized to write compensation insurance in this State.

(b) By securing from the Director of Industrial Relations a certificate of consent to self-insure, which may be given upon furnishing proof satisfactory to the Director of Industrial Relations of ability to self-insure and to pay any compensation that may become due to his employees.

I am aware of the provisions of section 3700 of the Labor Code which require every employer to be insured against liability for workers' compensation or to undertake self-insurance in accordance with the provisions of that code, and I will comply with such provisions before commencing the performance of the work of this contract.

**PACIFIC HYDROTECH CORPORATION:**

\_\_\_\_\_

BY: \_\_\_\_\_

TITLE: \_\_\_\_\_

DATE: \_\_\_\_\_

In accordance with Article 5 (commencing at section 1860), chapter 1, part 7, division 2 of the Labor Code, the above certificate must be signed and filed with the awarding body prior to performing any work under this contract.

## ATTACHMENT 5

### PUBLIC WORKS CONTRACTOR REGISTRATION CERTIFICATION

Pursuant to Labor Code sections 1725.5 and 1771.1, all contractors and subcontractors that wish to bid on, be listed in a bid proposal, or enter into a contract to perform public work must be registered with the Department of Industrial Relations. See <http://www.dir.ca.gov/Public-Works/PublicWorks.html> for additional information.

No bid will be accepted nor any contract entered into without proof of the contractor's and subcontractors' current registration with the Department of Industrial Relations to perform public work.

Design-Build Entity hereby certifies that it is aware of the registration requirements set forth in Labor Code sections 1725.5 and 1771.1 and is currently registered as a contractor with the Department of Industrial Relations.<sup>1</sup>

Name of Design-Build Entity : \_\_\_\_\_

DIR Registration Number: \_\_\_\_\_

DIR Registration Expiration: \_\_\_\_\_

Small Project Exemption: \_\_\_\_\_ Yes or \_\_\_\_\_ No

Unless Design-Build Entity is exempt pursuant to the small project exemption, Design-Build Entity further acknowledges:

- Design-Build Entity shall maintain a current DIR registration for the duration of the project.
- Design-Build Entity shall include the requirements of Labor Code sections 1725.5 and 1771.1 in its contract with subcontractors and ensure that all subcontractors are registered at the time of bid opening and maintain registration status for the duration of the project.
- Failure to submit this form or comply with any of the above requirements may result in a finding that the bid is non-responsive.

<sup>1</sup> If the Project is exempt from the contractor registration requirements pursuant to the small project exemption under Labor Code Sections 1725.5 and 1771.1, please mark "Yes" in response to "Small Project Exemption."

Name of Design-Build Entity\_\_\_\_\_

Signature\_\_\_\_\_

Name and Title\_\_\_\_\_

Dated\_\_\_\_\_

**DATE:** June 16, 2026

**TO:** Honorable Mayor and City Council

**FROM:** Lisa L. Flores, Development Services Director  
By: Fiona Graham, Planning Services Manager

**SUBJECT:** FINAL TRACT MAP NO. 84785 TO CONSOLIDATE TWO LEGAL LOTS AS ONE LOT TO ACCOMMODATE A 10-UNIT RESIDENTIAL CONDOMINIUM SUBDIVISION AT 36 AND 42 EAST COLORADO BOULEVARD

**CEQA: Exempt**

**Recommendation: Approve**

### **SUMMARY**

Tentative tract maps and final maps are required for all subdivisions and condominium projects. In accordance with Section 9105.05.050 of the Arcadia Development Code, the City Council shall approve a final map if it conforms to all requirements of the subdivision regulations of the Development Code and the Subdivision Map Act. Tentative Tract Map No. TTM 25-02 (84785) was conditionally approved by the Planning Commission on September 9, 2025, to consolidate two (2) legal lots and subdivide the airspace for an approved 10-unit multifamily project, located at 36 and 42 E. Colorado Boulevard.

Final Tract Map No. 84785 has met all applicable criteria for subdivision – refer to Attachment No. 1. Therefore, it is recommended that the City Council approve Final Tract Map No. 84785, along with a Categorical Exemption under the California Environmental Quality Act (“CEQA”).

### **DISCUSSION**

On April 15, 2025, the Development Services Department approved a three-story 10-unit multifamily project at 36 and 42 E. Colorado Boulevard, subject to Senate Bill (“SB”) 330 streamlined processing. The Applicant also applied for Tentative Tract Map

No. TTM 25-02 (84785) to consolidate the two properties and subdivide the airspace. As SB 330 does not apply to maps, the Planning Commission reviewed TTM 25-02 (84785) at its September 9, 2025, regular meeting, and approved it unanimously.

The Final Tract Map submitted by the Applicant/Property Owner satisfies all conditions of approval set forth in the Tentative Map and has been reviewed by the Los Angeles County Department of Public Works – refer to Attachment No. 2. The Map has been found to be in substantial compliance with both the Tentative Map, as conditionally approved by the Planning Commission, and the subdivision regulations of Arcadia’s Development Code and the State Subdivision Map Act.

A Certificate of Occupancy will not be issued until the Map has been approved and recorded by the Los Angeles County Recorder’s Office.

### **ENVIRONMENTAL ANALYSIS**

Final Tract Map No. 84785 is Categorically Exempt from environmental review under the California Environmental Quality Act (“CEQA”) pursuant to Section 15332 of the CEQA Guidelines as an infill development project. The Planning Commission affirmed this finding and conditionally approved Tentative Tract Map No. TTM 25-02 (84785) at its regular meeting on September 9, 2025.

### **FISCAL IMPACT**

There will be no fiscal impact to the City as a result of approving the Final Tract Map.

### **RECOMMENDATION**

It is recommended that the City Council approve Final Tract Map No. 84785 with a Categorical Exemption under the California Environmental Quality Act (“CEQA”) to consolidate two legal lots as one lot to accommodate an approved 10-unit residential condominium subdivision at 36 and 42 East Colorado Boulevard.

Approved:



Dominic Lazzaretto  
City Manager

Attachment No. 1: Final Tract Map No. 84785

Attachment No. 2: Letter of Compliance from Los Angeles County Department of  
Public Works

1 LOT  
14,750 SQ. FT.

# TRACT NO. 84785

SHEET 1 OF 2 SHEETS

IN THE CITY OF ARCADIA  
COUNTY OF LOS ANGELES, STATE OF CALIFORNIA  
BEING A SUBDIVISION OF A PORTION OF LOTS 24 AND 25, IN  
BLOCK 82, OF A PART OF ARCADIA SANTA ANITA TRACT, AS  
PER MAP RECORDED IN BOOK 15, PAGES 89 AND 90 OF  
MISCELLANEOUS RECORDS, IN THE OFFICE OF THE COUNTY  
RECORDER OF SAID COUNTY.

### FOR CONDOMINIUM PURPOSES

#### OWNER'S STATEMENT:

WE HEREBY STATE THAT WE ARE THE OWNERS OF OR ARE INTERESTED IN THE LANDS INCLUDED WITHIN THE SUBDIVISION SHOWN ON THIS MAP WITHIN THE DISTINCTIVE BORDER LINES, AND WE CONSENT TO THE PREPARATION AND FILING OF SAID MAP AND SUBDIVISION.

WE HEREBY DEDICATE TO THE PUBLIC THE EASEMENT FOR STREET, HIGHWAY, AND OTHER PUBLIC WAYS SHOWN ON SAID MAP.

MESA COL, LLC, A CALIFORNIA LIMITED LIABILITY COMPANY (OWNER)

\_\_\_\_\_  
JANET CHAN (MANAGER)

#### BENEFICIARY:

EAST WEST BANK, BENEFICIARY UNDER A DEED OF TRUST RECORDED NOVEMBER 15, 2024, AS DOCUMENT NO. 20240793182 OF OFFICIAL RECORDS, RECORDS OF THE COUNTY OF LOS ANGELES.

\_\_\_\_\_  
PRINT NAME TITLE

A NOTARY PUBLIC OR OTHER OFFICER COMPLETING THIS CERTIFICATE VERIFIES ONLY THE IDENTITY OF THE INDIVIDUAL WHO SIGNED THE DOCUMENT TO WHICH THIS CERTIFICATE IS ATTACHED, AND NOT THE TRUTHFULNESS, ACCURACY, OR VALIDITY OF THAT DOCUMENT.

STATE OF CALIFORNIA )  
COUNTY OF LOS ANGELES )  
ON \_\_\_\_\_ BEFORE ME, \_\_\_\_\_, A NOTARY PUBLIC

PERSONALLY APPEARED \_\_\_\_\_ WHO PROVED TO ME ON THE BASIS OF SATISFACTORY EVIDENCE TO BE THE PERSON(S) WHOSE NAME(S) IS/ARE SUBSCRIBED TO THE WITHIN INSTRUMENT AND ACKNOWLEDGED TO ME THAT HE/SHE/THEY EXECUTED THE SAME IN HIS/HER/THEIR AUTHORIZED CAPACITY(IES), AND THAT BY HIS/HER/THEIR SIGNATURE(S) ON THE INSTRUMENT THE PERSONS, OR THE ENTITY UPON BEHALF OF WHICH THE PERSONS ACTED, EXECUTED THE INSTRUMENT.

I CERTIFY UNDER PENALTY OF PERJURY UNDER THE LAWS OF THE STATE OF CALIFORNIA THAT THE FOREGOING PARAGRAPH IS TRUE AND CORRECT.

WITNESS MY HAND AND OFFICIAL SEAL

SIGNATURE \_\_\_\_\_

PRINT NAME: \_\_\_\_\_

MY PRINCIPAL PLACE OF BUSINESS IS IN LOS ANGELES COUNTY.

MY COMMISSION NO. \_\_\_\_\_ MY COMMISSION EXPIRES \_\_\_\_\_

A NOTARY PUBLIC OR OTHER OFFICER COMPLETING THIS CERTIFICATE VERIFIES ONLY THE IDENTITY OF THE INDIVIDUAL WHO SIGNED THE DOCUMENT TO WHICH THIS CERTIFICATE IS ATTACHED, AND NOT THE TRUTHFULNESS, ACCURACY, OR VALIDITY OF THAT DOCUMENT.

STATE OF CALIFORNIA )  
COUNTY OF LOS ANGELES )  
ON \_\_\_\_\_ BEFORE ME, \_\_\_\_\_, A NOTARY PUBLIC

PERSONALLY APPEARED \_\_\_\_\_ WHO PROVED TO ME ON THE BASIS OF SATISFACTORY EVIDENCE TO BE THE PERSON(S) WHOSE NAME(S) IS/ARE SUBSCRIBED TO THE WITHIN INSTRUMENT AND ACKNOWLEDGED TO ME THAT HE/SHE/THEY EXECUTED THE SAME IN HIS/HER/THEIR AUTHORIZED CAPACITY(IES), AND THAT BY HIS/HER/THEIR SIGNATURE(S) ON THE INSTRUMENT THE PERSONS, OR THE ENTITY UPON BEHALF OF WHICH THE PERSONS ACTED, EXECUTED THE INSTRUMENT.

I CERTIFY UNDER PENALTY OF PERJURY UNDER THE LAWS OF THE STATE OF CALIFORNIA THAT THE FOREGOING PARAGRAPH IS TRUE AND CORRECT.

WITNESS MY HAND AND OFFICIAL SEAL

SIGNATURE \_\_\_\_\_

PRINT NAME: \_\_\_\_\_

MY PRINCIPAL PLACE OF BUSINESS IS IN LOS ANGELES COUNTY.

MY COMMISSION NO. \_\_\_\_\_ MY COMMISSION EXPIRES \_\_\_\_\_

#### CONDOMINIUM NOTE:

THIS TRACT IS APPROVED AS A CONDOMINIUM PROJECT FOR 10 UNITS, WHEREBY THE OWNERS OF THE UNITS OF AIR SPACE WILL HOLD AN UNDIVIDED INTEREST IN THE COMMON AREAS THAT WILL, IN TURN, PROVIDE THE NECESSARY ACCESS AND UTILITY EASEMENTS FOR THE UNITS.

#### LOS ANGELES COUNTY TAX CERTIFICATE:

I HEREBY CERTIFY THAT ALL CERTIFICATES HAVE BEEN FILED AND DEPOSITS HAVE BEEN MADE THAT ARE REQUIRED UNDER THE PROVISIONS OF SECTIONS 66492 AND 66493 OF THE SUBDIVISION MAP ACT.

EXECUTIVE OFFICER, BOARD OF SUPERVISORS OF THE COUNTY OF LOS ANGELES, STATE OF CALIFORNIA

BY \_\_\_\_\_ DATE \_\_\_\_\_  
DEPUTY

I HEREBY CERTIFY THAT SECURITY IN THE AMOUNT OF \$ \_\_\_\_\_ HAS BEEN FILED WITH THE EXECUTIVE OFFICER, BOARD OF SUPERVISORS OF THE COUNTY OF LOS ANGELES AS SECURITY FOR THE PAYMENT OF TAXES AND SPECIAL ASSESSMENTS COLLECTED AS TAXES ON THE LAND SHOWN ON MAP OF TRACT NO. 84785 AS REQUIRED BY LAW.

EXECUTIVE OFFICER, BOARD OF SUPERVISORS OF THE COUNTY OF LOS ANGELES, STATE OF CALIFORNIA

BY \_\_\_\_\_ DATE \_\_\_\_\_  
DEPUTY

#### SURVEYOR'S STATEMENT:

THIS MAP WAS PREPARED BY ME OR UNDER MY DIRECTION AND IS BASED UPON A TRUE AND COMPLETE FIELD SURVEY PERFORMED BY ME OR UNDER MY DIRECTION IN SEPTEMBER, 2019, IN CONFORMANCE WITH THE REQUIREMENTS OF THE SUBDIVISION MAP ACT AND LOCAL ORDINANCE AT THE REQUEST OF JANET CHAN OF MESA COL, LLC, ON JANUARY 8, 2025. I HEREBY STATE THAT THIS FINAL MAP SUBSTANTIALLY CONFORMS TO THE CONDITIONALLY APPROVED TENTATIVE MAP; THAT ALL THE MONUMENTS ARE OF THE CHARACTER AND OCCUPY THE POSITIONS INDICATED; THAT SAID MONUMENTS ARE SUFFICIENT TO ENABLE THE SURVEY TO BE RETRACED.

\_\_\_\_\_  
JACK C. LEE, LS 8407 DATE \_\_\_\_\_  
EXPIRES: 6-30-2026



#### BASIS OF BEARING:

THE BEARINGS SHOWN HEREON ARE BASED ON THE BEARING N89°59'10"E OF THE CENTERLINE OF COLORADO BOULEVARD AS SHOWN ON MAP OF PARCEL MAP NO. 35229 RECORDED IN BOOK 900 PAGES 96 AND 97 OF MAPS, RECORDS OF LOS ANGELES COUNTY.

#### CITY ENGINEER'S CERTIFICATE:

I HEREBY CERTIFY THAT I HAVE EXAMINED THIS MAP; THAT IT CONFORMS SUBSTANTIALLY TO THE TENTATIVE MAP AND ALL APPROVED ALTERATIONS THEREOF; THAT ALL PROVISIONS OF SUBDIVISION ORDINANCES OF THE CITY OF ARCADIA APPLICABLE AT THE TIME OF APPROVAL OF THE TENTATIVE MAP HAVE BEEN COMPLIED WITH; AND THAT I AM SATISFIED THAT THIS MAP IS TECHNICALLY CORRECT WITH RESPECT TO CITY RECORDS.

\_\_\_\_\_  
DATE CITY ENGINEER, CITY OF ARCADIA  
KEVIN MERRILL  
R.C.E. 73799 EXPIRES: 6-30-2027

#### CITY TREASURER'S CERTIFICATE:

I HEREBY CERTIFY THAT ALL SPECIAL ASSESSMENTS LEVIED UNDER THE JURISDICTION OF THE CITY OF ARCADIA, TO WHICH THE LAND INCLUDED IN THE WITHIN SUBDIVISION OR ANY PART THEREOF IS SUBJECT, AND WHICH MAY BE PAID IN FULL, HAVE BEEN PAID IN FULL.

\_\_\_\_\_  
DATE CITY TREASURER  
CITY OF ARCADIA

#### PLANNING COMMISSION'S CERTIFICATE:

THIS IS TO CERTIFY THAT THE TENTATIVE MAP OF TRACT NO. 84785 WAS APPROVED AT A MEETING HELD ON THE \_\_\_\_\_ DAY OF \_\_\_\_\_, 20\_\_\_\_. I HEREBY CERTIFY THAT THIS MAP SUBSTANTIALLY COMPLIES WITH THE PREVIOUSLY APPROVED TENTATIVE MAP.

\_\_\_\_\_  
DATE SECRETARY OF THE PLANNING COMMISSION  
CITY OF ARCADIA

#### FINANCE DIRECTOR'S CERTIFICATE:

I HEREBY CERTIFY THAT THE FEE REQUIRED BY SECTION 9118.4 OF THE MUNICIPAL CODE HAS BEEN PAID TO THE CITY OF ARCADIA.

\_\_\_\_\_  
DATE FINANCE DIRECTOR - CITY OF ARCADIA

#### CITY CLERK'S CERTIFICATE:

I HEREBY CERTIFY THAT THE CITY COUNCIL OF THE CITY OF ARCADIA BY MOTION PASSED ON \_\_\_\_\_ APPROVED THE ATTACHED MAP AND DO ACCEPT ON BEHALF OF THE PUBLIC, THE EASEMENT FOR STREET, HIGHWAY, AND OTHER PUBLIC WAYS PURPOSES SHOWN HEREON.

\_\_\_\_\_  
DATE CITY CLERK - CITY OF ARCADIA

#### COUNTY SURVEYOR'S CERTIFICATE:

I HEREBY CERTIFY THAT I HAVE EXAMINED THIS MAP; THAT IT COMPLIES WITH ALL PROVISIONS OF STATE LAW APPLICABLE AT THE TIME OF APPROVAL OF THE TENTATIVE MAP; AND THAT I AM SATISFIED THAT THIS MAP IS TECHNICALLY CORRECT IN ALL RESPECTS NOT CERTIFIED BY THE CITY ENGINEER.

COUNTY SURVEYOR

\_\_\_\_\_  
BY DIEGO G. RIVERA, DEPUTY DATE \_\_\_\_\_  
L.S. NO. 9742





# COUNTY OF LOS ANGELES

## DEPARTMENT OF PUBLIC WORKS

*"To Enrich Lives Through Effective and Caring Service"*

MARK PESTRELLA, Director

900 SOUTH FREMONT AVENUE  
ALHAMBRA, CALIFORNIA 91803-1331  
Telephone: (626) 458-5100  
<http://dpw.lacounty.gov>

ADDRESS ALL CORRESPONDENCE TO:  
P.O. BOX 1460  
ALHAMBRA, CALIFORNIA 91802-1460

January 8, 2026

IN REPLY PLEASE

REFER TO FILE: **LD-2**

Mr. Kevin Merrill  
City Engineer  
City of Arcadia  
P.O. Box 60021  
Arcadia, CA 91006-6021

Dear Mr. Merrill:

### **TRACT 84785**

Tract 84785 (enclosed) has been reviewed and approved by Public Works for mathematical accuracy, survey analysis, title information, and for compliance with the California Subdivision Map Act. It is ready for your examination and certification as to compliance with the conditions of approval and applicable City ordinances.

The City Council or Advisory Agency should make the findings required by the California Environmental Quality Act and the California Subdivision Map Act.

After your approval and the approval of the City Council or Advisory Agency, the final map should be returned to Los Angeles County Public Works, Land Development Division, for filing with the Registrar-Recorder/County Clerk's office.

If you have any questions, please contact Mr. Max Rodriguez of Public Works, Land Development Division, at (626) 458-4915 or [mrodrigue@pw.lacounty.gov](mailto:mrodrigue@pw.lacounty.gov).

Very truly yours,

MARK PESTRELLA, PE  
Director of Public Works

YONAH HALPERN, PE  
Assistant Deputy Director  
Land Development Division

MR:tb

P:\LD\PUB\SUBMAP\LETTERS\CITY LETTERS - TRACT 84177\CITY LETTER (ARCADIA)2.DOC

Enc.

**DATE:** June 16, 2026

**TO:** Honorable Mayor and City Council

**FROM:** Chen Suen, Fire Chief  
By: Tom Devlin, Battalion Chief

**SUBJECT:** PURCHASE ORDER WITH ZERO INFRASTRUCTURE MOBILITY SOLUTIONS DBA CONNECTED SIGNALS FOR THE PURCHASE OF NEXT-GENERATION EMERGENCY VEHICLE TRAFFIC SIGNAL PREEMPTION SYSTEM SERVICES IN THE AMOUNT OF \$52,000  
**CEQA: Not a Project**  
**Recommendation: Approve**

### **SUMMARY**

As part of the Fiscal Year 2025-26 Equipment Acquisition Budget, funding has been allocated for the Fire Department's Emergency Vehicle Traffic Signal Preemption ("EVP") System project to improve emergency response safety and efficiency through traffic signal prioritization in the City. This project was initiated in FY 2024-25 in partnership with Zero Infrastructure Mobility Services dba Connected Signals ("Connected Signals") and included software customization, testing, and system integration for an initial testing period. Approval of the proposed Purchase Order will allow for full implementation, deployment, and ongoing operation of the system. It is recommended that the City Council approve a sole source Purchase Order with Zero Infrastructure Mobility Solutions dba Connected Signals for cloud-based Next-Generation Emergency Vehicle Traffic Signal Preemption ("EVP") System services, in the amount of \$52,000.

### **BACKGROUND**

An EVP system is designed to allow the normal operation of traffic lights to be "preempted." Essentially, the purpose of the system is to improve the safety and

efficiency of emergency response by allowing responding vehicles to request temporary traffic signal priority during Code 3 emergencies. The proposed EVP system is designed to provide traffic signal prioritization at 64 of the City's 65 signalized intersections by utilizing the City's existing traffic management network. In Fiscal Year 2022-23, a trial period was provided to several traffic management systems to evaluate their ability to provide an EVP system that would work with the City's traffic management network. Connected Signals was the only vendor that successfully demonstrated a fully functional solution capable of integrating with the City's existing wireless traffic management system, without requiring significant additional hardware or infrastructure modifications.

As a two-phase project involving system build-out, including testing, monitoring, traffic signal analysis, and deployment, in FY 2024-25, the EVP System project was initiated. Connected Signals has now completed its software customization and upgrades, system integration, and deployment plan. The second phase of the project in FY 2025-26 will enable the full implementation of the EVP System with the City's traffic management system.

Procuring services from another vendor at this stage would require substantial redevelopment of existing integrations, additional testing and validation, potential infrastructure modifications, and duplication of costs already incurred by the City.

## **DISCUSSION**

Based on data collected during the pilot and implementation period, there has been a noticeable improvement on the average emergency response times when the EVP system was utilized. The system also resulted in route efficiency by reducing braking events and minimizing stop-and-go driving occurrences during emergency responses, which contributed to smoother and safer vehicle operation. While emergency response times can vary based on call type, location, traffic conditions, and other operational factors, the pilot period demonstrated measurable improvements in emergency vehicle travel throughout the City when the EVP system was utilized.

Connected Signals has developed a cloud-based, machine learning platform designed to provide traffic management and signal prioritization capabilities. The system requires no physical hardware installation at intersections and can be

deployed immediately after the implementation. It supports multi-intersection coordination, with customized signal timing and prioritization based on vehicle type, including elevated service priority for ambulances. Additional features include backup connectivity, caravanning functionality for coordinated vehicle movement, and a digital twin interface for real-time visualization of signal and route behavior.

The proposed services include:

- Deployment and maintenance of the cloud-based EVP platform;
- Software customization and support for Arcadia Fire Department operations;
- Integration with existing traffic management infrastructure;
- Ongoing technical support and system monitoring;
- Performance reporting and traffic signal analysis; and
- Continued system maintenance and operational support.

The total cost of the proposed services is \$52,000. Following implementation, ongoing maintenance and support costs are anticipated to be approximately \$19,500 annually and will be included in future operating budgets, subject to annual appropriations.

### **ENVIRONMENTAL ANALYSIS**

The proposed action does not constitute a project under the California Environmental Quality Act ("CEQA"), and it can be seen with certainty that it will have no impact on the environment.

### **FISCAL IMPACT**

The total cost for cloud-based Next-Generation Emergency Vehicle Traffic Signal Preemption ("EVP") System services is \$52,000. Sufficient funds have been allocated in the Fiscal Year 2025-26 Equipment Acquisition Budget for this project. The ongoing maintenance costs of \$19,500 per year have been budgeted in the FY 2026-27 Fire Operating Budget and will be included in subsequent budget years, subject to annual appropriations by the City Council.

**RECOMMENDATION**

It is recommended that the City Council find that the proposed action does not constitute a project under the California Environmental Quality Act ("CEQA"); and approve a sole source Purchase Order with Zero Infrastructure Mobility Solutions dba Connected Signals for the purchase of Next-Generation Emergency Vehicle Traffic Signal Preemption System services in the amount of \$52,000.

Approved:

  
Dominic Lazzaretto  
City Manager

**DATE:** June 16, 2026

**TO:** Honorable Mayor and City Council

**FROM:** Darlene Bradley, Library and Museum Services Director

**SUBJECT:** PURCHASE ORDER WITH TSAI FONG FOR INTERNATIONAL LANGUAGE MATERIALS IN AN AMOUNT NOT TO EXCEED \$35,000  
**CEQA: Not a Project**  
**Recommendation: Approve**

**SUMMARY**

It is recommended that the City Council approve a Purchase Order with Tsai Fong for international language materials, including simplified and traditional Chinese materials, in an amount not to exceed \$35,000. Sufficient funds are available in the City's Fiscal Year 2026-27 Operating Budget to support this purchase.

**DISCUSSION**

Tsai Fong provides certain international language titles at a discounted price. This vendor provides English translation titles and invoices necessary to purchase titles in Chinese, Vietnamese, and Korean. Although the Arcadia Public Library uses other vendors for international languages, Tsai Fong includes many popular international titles and authors, and provides cataloging records not found with other vendors. Tsai Fong provides this important cataloging feature and is therefore the City's sole-source supplier for these materials.

The estimated cost for Fiscal Year 2026-27 is \$35,000. Sufficient funds are available in the City's Fiscal Year 2026-27 Operating Budget for this purchase. Therefore, it is recommended that the City Council approve this Purchase Order with Tsai Fong.

## **ENVIRONMENTAL ANALYSIS**

The proposed action does not constitute a project under Section 15061(b)(3) of the California Environmental Quality Act ("CEQA"), as it can be seen with certainty that it will have no impact on the environment.

## **FISCAL IMPACT**

Sufficient funds have been approved in the City's Fiscal Year 2026-27 General Fund Operating Budget for this purchase.

## **RECOMMENDATION**

It is recommended that the City Council determine that this action is not a project under the California Environmental Quality Act ("CEQA"); and approve a Purchase Order with Tsai Fong for international language materials in an amount not to exceed \$35,000.

Approved:



Dominic Lazzaretto  
City Manager

**DATE:** June 16, 2026

**TO:** Honorable Mayor and City Council

**FROM:** Henry Chen, Administrative Services Director

**SUBJECT:** PURCHASE ORDERS FOR ANNUAL SOFTWARE HOSTING AND MAINTENANCE SERVICES WITH ORACLE AMERICA FOR NETSUITE FOR GOVERNMENT AND CAN/AM TECHNOLOGIES FOR TELLER CASHIERING, IN AN AMOUNT NOT TO EXCEED \$177,900

**CEQA: Not a Project**  
**Recommendation: Approve**

### **SUMMARY**

The City currently uses NetSuite for Government (“NetSuite”) from Oracle America and Teller cashiering system (“Teller”) from Can/Am Technologies to support financial management and cashiering operations. Both systems require annual licensing, cloud hosting, and maintenance fees. It is recommended that the City Council approve two Purchase Orders in Fiscal Year 2026-27: one with Oracle America for \$118,000 and one with Can/Am Technologies for \$59,900, for a total of \$177,900 for annual software hosting and maintenance.

### **DISCUSSION**

NetSuite and Teller were implemented last fiscal year to replace the City’s legacy FinancePlus system, which had been in use since 1999. These platforms support essential Finance, Purchasing, and Human Resources functions, including payroll, accounts payable, accounts receivable, budget preparation, general ledger, cashiering, and financial reporting. Annual hosting and maintenance fees fund cloud hosting services, ongoing product enhancements, security updates, and program improvements, along with phone and web-based technical support.

The annual cost for Fiscal Year 2026-27 is approximately \$118,000 for Oracle NetSuite and \$59,900 for Teller, for a total annual cost of \$177,900, an increase of about 3.1% from the prior year. It is recommended that the City issue Purchase Orders to Oracle America and Can/Am Technologies for annual hosting and maintenance services.

### **ENVIRONMENTAL ANALYSIS**

The proposed action does not constitute a project under the California Environmental Quality Act ("CEQA"), under Section 15061(b)(3) of the CEQA Guidelines, as it can be seen with certainty that it will have no impact on the environment.

### **FISCAL IMPACT**

Sufficient funds for the proposed annual hosting and maintenance costs are budgeted in the FY 2026-27 Operating Budget.

### **RECOMMENDATION**

It is recommended that the City Council find that the proposed action does not constitute a project under the California Environmental Quality Act ("CEQA"); and approve Purchase Orders with Oracle America and Can/Am Technologies for annual hosting and maintenance of the City's financial system software for Fiscal Year 2026-27, in an amount not to exceed \$177,900.

Approved:

  
Dominic Lazzaretto  
City Manager

**DATE:** June 16, 2026

**TO:** Honorable Mayor and City Council

**FROM:** Henry Chen, Administrative Services Director  
By: Wilson Luo, Information Technology Manager

**SUBJECT:** PURCHASE ORDER WITH NETSYNC, INC. FOR PURE STORAGE ANNUAL MAINTENANCE AND SUPPORT IN THE AMOUNT OF \$43,489  
**CEQA: Not a Project**  
**Recommendation: Approve**

### **SUMMARY**

The City utilizes Pure Storage Flash Array storage area networks (“SAN”) to host its core software infrastructure across two primary operating environments: City Hall and the Police Department. These arrays hold the City's virtual server environments, databases, operational logs, and public safety data. The current manufacturer's warranty and support agreements are approaching expiration. Securing these renewals guarantees continued 24/7 engineering support, automated hardware monitoring, and seamless software updates, vital for system uptime and institutional cybersecurity resilience.

Utilizing NASPO ValuePoint, a national cooperative purchasing program, allows the City to streamline the purchasing process and receive the best price possible. It is recommended that the City Council approve a purchase order with Netsync, Inc. for Pure Storage annual maintenance and support, in the amount \$43,489.

### **BACKGROUND**

The City relies on an enterprise storage area network (“SAN”) manufactured by Pure Storage to host its entire centralized data infrastructure. There is a single system overseeing all City departments except for the Police Department, which must be separated to meet federal and state security requirements. Enterprise data services

were migrated to Pure Storage flash hardware architecture to eliminate storage latency, improve server recovery speeds, and reduce the physical server room footprint. Rather than running a single centralized site, the City maintains a split-architecture layout across two distinct facilities to guarantee operational independence and security:

- City Hall Array: Powers the municipal administration network, including Enterprise Resource Planning (“ERP”) financial software, local Land Management Systems (“LMS”), municipal GIS mapping infrastructure, internal communication channels, and administrative documentation databases.
- Police Department Array: Formulates the foundation for the Public Safety network infrastructure, handling high-availability systems such as the Computer-Aided Dispatch (“CAD”) logging systems, Records Management Systems (“RMS”), digital forensic storage networks, and connection pipelines to regional law enforcement databases.

The hardware uses a high-performance all-flash architecture to ensure rapid data access and stability across all departments. To maintain data integrity, operational continuity, and security compliance, the system requires an active, manufacturer-certified annual maintenance and support agreement.

## **DISCUSSION**

The requested purchase order offers comprehensive enterprise coverage provided directly by the original equipment manufacturer, Pure Storage, Inc. This procurement maintains the integrity of the hardware infrastructure through three primary pillars of coverage:

1. Predictive Engineering and Component Replacement: Both storage arrays constantly relay telemetry data back to the manufacturer via secure channels. Pure Storage's automated monitoring platform flags hardware errors, such as flash cell degradation or controller vulnerabilities, before they affect operations. Replacement components are automatically packaged and dispatched for priority overnight delivery, protecting both municipal and public safety data networks from unexpected hardware failures.

2. Security Patching and Continuous Firmware Optimization: Ransomware and cyber-extortion vectors frequently target enterprise backup and infrastructure systems. Active maintenance agreements guarantee immediate access to critical operating system upgrades, cryptographic security hotfixes, and system enhancements that harden storage arrays against emerging exploits.
3. 24/7/365 Tier-1 Engineering Support: For public safety operations, a data outage is a critical emergency. This support contract provides the City's IT engineers with instantaneous, unmitigated access to Tier-1 senior storage architects to rapidly remediate any localized storage area network anomalies.

The California Government Code authorizes public agencies to utilize existing cooperative purchasing agreements that have been competitively bid, without conducting a separate formal bid process, resulting in administrative efficiencies and cost savings. NASPO awarded a cooperative purchasing contract to Netsync, Inc. for Pure Storage maintenance services for personal computing devices, servers, and storage. The Information Technology Division has reviewed the contract, and it was determined to meet the City's procurement and specification requirements.

### **ENVIRONMENTAL ANALYSIS**

The proposed action does not constitute a project under the California Environmental Quality Act ("CEQA"), under Section 15061(b)(3) of the CEQA Guidelines, as it can be seen with certainty that it will have no impact on the environment.

### **FISCAL IMPACT**

The total cost for this annual maintenance contract is \$43,489. Sufficient funds have been budgeted in the Fiscal Year 2026-27 Operating Budget for this purchase.

### **RECOMMENDATION**

It is recommended that the City Council determine this action is not a project under the California Environmental Quality Act ("CEQA"); and approve a Purchase Order with Netsync, Inc. for Pure Storage annual maintenance and support in the amount of \$43,489.

Approved:

A handwritten signature in blue ink, appearing to read 'Dominic Lazzaretto', written over a horizontal line.

Dominic Lazzaretto  
City Manager

**DATE:** June 16, 2026

**TO:** Honorable Mayor and City Council

**FROM:** Darlene Bradley, Library and Museum Services Director

**SUBJECT:** PURCHASE ORDER WITH OCLC, INC. FOR BIBLIOGRAPHIC SERVICES AND METADATA IN AN AMOUNT NOT TO EXCEED \$32,000  
**CEQA: Not a Project**  
**Recommendation: Approve**

### **SUMMARY**

The Arcadia Public Library uses OCLC, Inc. to provide catalog metadata and maintain records for its interlibrary loan services that include more than 16,000 member libraries. It is recommended that the City Council approve a Purchase Order for bibliographic services and metadata from OCLC, Inc., in an amount not to exceed \$32,000. Sufficient funds are available in the City's Fiscal Year 2026-27 Operating Budget for this purchase.

### **BACKGROUND**

The Arcadia Public Library uses the services of OCLC, Inc. as the supplier of metadata for its public catalog, as well as maintaining a record of its 200,000 items used in providing Inter-Library Loan service to the public. OCLC is a nonprofit cooperative organization that maintains a database of the collections of more than 16,000 member libraries, which are continually updated to enhance accuracy and completeness.

### **DISCUSSION**

The estimated cost of \$32,000 for OCLC's services is based on historical usage. In addition to the cost for cataloging and metadata, there is a fee of \$892.70 per year, for an online product that helps staff select the appropriate Dewey Decimal number for new items. In addition to regular search fees (which vary depending on

complexity) and postage costs for returning items to lending libraries, there is an annual fee for searching and requesting Inter-Library Loan items. Patrons pay a \$5.00 fee for requesting an Inter-library loan item, which helps defray the cost of this service, and recovered costs are deposited into the General Fund.

Use of high-quality metadata is vital to connecting patrons with the library's collections. OCLC membership also greatly expands the range of holdings available from other libraries, so Arcadia Library patrons can request loans through the Inter-Library Loan service. It is recommended that the City Council approve a Purchase Order for bibliographic services and metadata from OCLC, Inc., in an amount not to exceed \$32,000. Sufficient funds are available in the City's Fiscal Year 2026-27 Operating Budget for this purchase.

### **ENVIRONMENTAL ANALYSIS**

The proposed action does not constitute a project under the California Environmental Quality Act ("CEQA"), and it can be seen with certainty that it will have no impact on the environment.

### **FISCAL IMPACT**

Sufficient funds have been approved in the City's FY 2026-27 Operating Budget for this Purchase Order.

### **RECOMMENDATION**

It is recommended that the City Council determine that this action does not constitute a project under the California Environmental Quality Act ("CEQA"); and approve a Purchase Order with OCLC, Inc. for bibliographic services and metadata in an amount not to exceed \$32,000.

Approved:

  
Dominic Lazzaretto  
City Manager

**DATE:** June 16, 2026

**TO:** Honorable Mayor and City Council

**FROM:** Darlene Bradley, Library and Museum Services Director

**SUBJECT:** PURCHASE ORDER WITH OVERDRIVE, INC. FOR EBOOKS, EMAGAZINES, DIGITAL AUDIOBOOKS, AND STREAMING VIDEOS IN AN AMOUNT NOT TO EXCEED \$80,000  
**CEQA: Not a Project**  
**Recommendation: Approve**

### **SUMMARY**

It is recommended that the City Council approve a Purchase Order for electronic books, electronic magazines, digital audiobooks, and streaming videos from OverDrive, Inc., in an amount not to exceed \$80,000. Sufficient funds are available in the City's Fiscal Year 2026-27 Operating Budget for this purchase.

### **DISCUSSION**

Since 2011, the Arcadia Public Library has utilized the services of OverDrive, Inc. ("OverDrive") to provide patrons with access to electronic books, digital audiobooks, and streaming videos. OverDrive, Inc. is the leading distributor of these materials to libraries, where titles are curated and selected by staff. Titles purchased through Overdrive are available to the Library's patrons on computers, tablets, eReaders, or smartphones.

The Arcadia Public Library has access to OverDrive through membership in the company's group of local customer libraries, the Southern California Digital Library Consortium, which combines the digital collections of 25-member libraries to provide added selection for patrons.

The Library also adds to its collection in the Consortium by purchasing individual electronic books, digital audiobooks, and digital videos from OverDrive. These titles include current bestsellers, older classic titles, and titles for adults, teens, and children. Spending for these items has been growing with the increasing popularity of the digital format and usage by Library patrons continues to increase yearly. Total spending for OverDrive during the next fiscal year is projected between \$75,000 and \$80,000. Sufficient funding has been allocated in the Fiscal Year 2026-27 Operating Budget for this purchase.

### **ENVIRONMENTAL ANALYSIS**

The proposed action does not constitute a project under Section 15061(b)(3) of the California Environmental Quality Act ("CEQA"), as it can be seen with certainty that it will have no impact on the environment.

### **FISCAL IMPACT**

Sufficient funds have been approved in the City's FY 2026-27 Operating Budget for this expense.

### **RECOMMENDATION**

It is recommended that the City Council determine that this action does not constitute under the California Environmental Quality Act ("CEQA"); and approve a Purchase Order with OverDrive, Inc. for eBooks, eMagazines, digital audiobooks, and streaming videos, in an amount not to exceed \$80,000.

Approved:

  
Dominic Lazzaretto  
City Manager

**DATE:** June 16, 2026

**TO:** Honorable Mayor and City Council

**FROM:** Paul Cranmer, Public Works Services Director  
By: Leonel Martin, Public Works Project Manager

**SUBJECT:** AMENDMENT TO THE PROFESSIONAL SERVICES AGREEMENT WITH JONES-WALBAUM CORPORATION DBA AMERICAN BUSINESS MACHINES FOR FIRE ALARM AND FIRE SUPPRESSION REPAIRS, AND ADDITIONAL ACCESS CONTROL PANELS, CAMERAS, AND EQUIPMENT IN THE AMOUNT OF \$384,398.38

**CEQA: Not a Project**

**Recommendation: Approve**

## **SUMMARY**

On July 15, 2025, the City Council authorized and directed the City Manager to execute a Professional Services Agreement (“PSA”) with Jones-Walbaum Corporation dba American Business Machines for security alarm and fire suppression system installation, monitoring, and repair services, and security camera and access control upgrade and installation, in the amount of \$883,916.77, with a 10% contingency. On January 20, 2026, the City Council approved an Amendment to the PSA, in the amount of \$101,276.29, for additional cameras needed for the Arcadia Police Department Jail. After completing inspections of the fire alarm and fire suppression systems, as well as installing security system equipment throughout all City facilities, it has been determined that a second amendment to the PSA is necessary.

Inspections of the fire alarm and fire suppression systems at all City facilities identified repairs necessary to meet National Fire Protection Association (“NFPA”) standards and local fire codes. It was also determined that an additional facility (Orange Grove Well Facility) requires access control and cameras, and that supplemental cameras, keypads, and panic buttons are needed at the Library,

Museum Education Center, Public Works Service Center, City Hall, and Fire Station 106.

Furthermore, after replacing all the cameras at the Police Department, it was discovered that the existing 53 cameras need to be rewired. The current CAT5 wiring was previously extended using legacy coaxial cable, which is not compatible with the new video recording system. The Police Department also needs a monitoring station and two intercoms.

It is recommended that the City Council approve, authorize, and direct the City Manager to execute a second amendment to the PSA with Jones-Walbaum Corporation dba American Business Machines for fire alarm and fire suppression repairs, and additional access control panels and cameras in the amount of \$384,398.38. This additional work is within the original budget for this project.

## **BACKGROUND**

Over the past few years, many City of Arcadia facilities have experienced persistent challenges with their security and access control systems. These challenges included inconsistent performance, outdated technology, and difficulty maintaining legacy systems that are no longer supported or efficient. As the reliability of these critical systems continued to decline, it became apparent that a Citywide upgrade to the security and fire alarm system was necessary.

On July 15, 2025, the City Council approved a PSA with Jones-Walbaum Corporation dba American Business Machines ("ABM"), in the amount of \$883,916.77, with a 10% contingency for security alarm and fire suppression system installation, monitoring, and repair services, and security camera and access control upgrade and installation. As part of this PSA, a new system that includes advanced access control solutions, upgraded fire protection systems, and state-of-the-art security monitoring tools, have been installed. Notable features of the new security system include cloud-based management software, mobile app integration, and high-resolution 4K security cameras. On January 20, 2026, the City Council approved an Amendment to the PSA, in the amount of \$101,276.29, for additional cameras needed for the Arcadia Police Department Jail.

The Public Works Services Department (“PWSD”) has been working with ABM to complete camera, access control, and security system installation at the Council Chambers, Community Center, Recreation Building, Museum Education Center, Gilb Museum, Library, and City Hall. Fire alarm/fire suppression inspections and reports have been completed for all facilities. The report results have determined that swapping individual parts to keep the existing systems operational is not feasible. The fire alarm/fire suppression systems at most facilities are outdated, and much of the existing hardware is obsolete and no longer manufactured, requiring replacement. Additionally, the City was unable to locate existing plans or schematics for most of the fire alarm systems, so a new set of plans will be produced for the City’s records. These plans will help identify and locate components that may fail in the future, allowing staff to address issues promptly.

Furthermore, it has been determined that additional equipment is still needed. The Orange Grove Well Facility requires an access control system and cameras, and supplemental cameras, keypads, and panic buttons are needed at certain locations at City Hall, the Library, Museum Education Center, Public Works Service Center, and Fire Station 106. After replacing all the cameras at the Police Department, it was discovered that the existing 53 cameras need to be rewired. The current CAT5 wiring was previously extended using legacy coaxial cable, which is not compatible with the new video recording system. The Police Department also needs a monitoring station and two intercoms. A second amendment to the PSA with ABM is necessary to include the necessary work, equipment, and plans.

## **DISCUSSION**

The PSA with ABM included the inspection of each facility's fire alarm and fire suppression systems, as well as reports identifying repairs needed to make each system fully operational and turnkey-ready. A monetary amount for these repairs could not be included in the original agreement because the condition of each system was unknown. The reports produced by ABM determined that swapping individual parts to keep the existing fire alarms/fire suppression systems operational is not feasible. The systems at most facilities are outdated, and much of the existing hardware is obsolete and no longer manufactured. To bring the systems online to operate efficiently, the existing hardware must be replaced with new strobes, fire alarms, dialers, and fire alarm panels. Portions of the system must also be rewired. Additionally, the City was unable to locate existing plans or schematics for most of

the fire alarm systems. As part of the amendment with ABM, a new set of plans will be produced.

The need for fire alarm/fire suppression system repairs is essential. At the Community Center, the fire alarm has activated for extended periods of time, disturbing patrons, and the fire door has triggered and closed randomly, presenting a safety risk. The City's previous security company repeatedly performed temporary fixes that would fail shortly after each visit, requiring the City to call them back to perform the same work over a period of years, at a cost of several hundred dollars per visit. These issues have also occurred at the Library and City Hall.

Furthermore, after determining that an additional water treatment system will be installed at the Orange Grove Well facility, it was decided that the access control should be updated and that cameras should be installed for additional security. The Orange Grove Well facility currently has access control; however, it operates on an older, standalone access control platform. Replacing it and consolidating the system onto the City's unified alarm system will allow staff to use the same credentials across all facilities.

Included as part of this amendment are additional cameras, keypads, and panic buttons at several existing facilities. City Hall will receive an additional control access keypad for the basement. The Arcadia Library will receive two additional cameras to address coverage gaps; recent incidents involving stolen bicycles and scooters have occurred in areas with no camera coverage. The Museum Education Center ("MEC") recently had an intruder gain entry through the rear of the building in an area not covered by a camera. The Gilb Museum and the MEC will each receive one panic button for emergency use. Public Works will receive two additional cameras to improve coverage of the yard in the event of intruders. Fire Station 106 will receive four additional cameras in locations where coverage has been identified as necessary, including the area in front of the flagpole, where recent vandalism has occurred, the secondary front entrance, and the rear gate.

Furthermore, this second amendment to the PSA will include the re-wiring of the cameras at the Police Department. It was recently discovered that the wiring of the existing 53 cameras at the Police Department consists of CAT5 wiring, which is not compatible with the new video recording system. In addition, three covert cameras will be installed in three interview rooms. The Police Department will also have an

additional monitoring station and two intercoms installed in the jail, Watch Commander's office, and the Chief's office.

### **ENVIRONMENTAL ANALYSIS**

The proposed action does not constitute a project under the California Environmental Quality Act ("CEQA"), as it can be seen with certainty that it will have no impact on the environment.

### **FISCAL IMPACT**

Funds in the amount of \$3.0 million were budgeted in the Fiscal Year 2024-25 Capital Improvement Program for this project. On July 15, 2025, the City Council executed a PSA in the amount of \$883,916.77, with a 10% contingency for the security alarm and fire suppression system installation, monitoring, and repair services and security camera and access control upgrade and installation. On January 20, 2026, the City Council approved an Amendment to the PSA in the amount of \$101,276.29, for additional cameras at the Arcadia Police Department Jail.

The total cost for the second Amendment to this PSA is \$384,398.38. With all proposed changes, the total cost of the agreement will increase to \$1,369,591.44. Adding a 10% contingency to that figure would raise the maximum cost to \$1,506,550.58, which is slightly over half of the budgeted amount. Therefore, sufficient funds are available in the Fiscal Year 2024-25 Capital Improvement Program to fund this amendment.

### **RECOMMENDATION**

It is recommended that the City Council determine that this action does not constitute a project under the California Environmental Quality Act ("CEQA"); and approve, authorize, and direct the City Manager to execute an amendment to the Professional Services Agreement with Jones-Walbaum Corporation dba American Business Machines for fire alarm and fire suppression repairs, and additional access control panels, cameras, and equipment in the amount of \$384,398.38, with a 10% contingency for all approved work.

Approved:



Dominic Lazzaretto  
City Manager

Attachment: Proposed Amendment No. 2 to the Professional Services Agreement



**AMENDMENT NO. 2 TO THE PROFESSIONAL SERVICES AGREEMENT FOR  
THE SECURITY ALARM AND FIRE SUPPRESSION SYSTEM INSTALLATION,  
MONITORING, AND REPAIR SERVICES AND SECURITY CAMERA AND ACCESS  
CONTROL UPGRADE AND INSTALLATION BY AND BETWEEN THE CITY OF  
ARCADIA AND AMERICAN BUSINESS MACHINES**

This Amendment No. 2 (“Amendment No. 2”) is hereby entered into this \_\_\_\_ day of \_\_\_\_\_, **2026** by and between the City of Arcadia, a municipal corporation of the State of California, and **American Business Machines**, a California Corporation, with respect to that certain Professional Services Agreement between the parties **dated October 14, 2025 (“Agreement”)**, further amended by **Amendment No. 1 dated March 10, 2026**, and further amended by **Amendment No. 2 dated \_\_\_\_\_**.

The Parties agree as follows:

1. Pursuant to Section 2(b) of the Agreement “Compensation”, the Compensation is hereby amended to provide an additional compensation (increase) to the original Agreement due, and as further amended by Amendment No. 1, and payable to the Contractor in an amount not to exceed **Three Hundred Eighty-Four Thousand, Three Hundred Eighty-Four Dollars and Thirty-Eight Cents (\$384,398.38)**, the compensation is amended as referenced in the attached Exhibit “B” – Schedule of Charges/Payments.
2. Pursuant to Section 1 of the Agreement “Services”, the Services are amended as referenced in the attached Exhibit “A” – Scope of Services.
3. All terms and provisions of the Agreement not amended by this Amendment No. 2 are hereby reaffirmed.

**[SIGNATURES ON FOLLOWING PAGE]**

In witness whereof the Parties have executed this Amendment No. 1 on the date set forth below.

**CITY OF ARCADIA**

**AMERICAN BUSINESS MACHINES**

By: \_\_\_\_\_  
Dominic Lazzaretto  
City Manager

By: \_\_\_\_\_  
Title: \_\_\_\_\_

Dated: \_\_\_\_\_

Dated: \_\_\_\_\_

ATTEST:

By: \_\_\_\_\_  
Title: \_\_\_\_\_

\_\_\_\_\_  
City Clerk

Dated: \_\_\_\_\_

APPROVED AS TO FORM:

CONCUR:

\_\_\_\_\_  
Michael J. Maurer  
City Attorney

\_\_\_\_\_  
Paul Cranmer  
Public Works Services Director

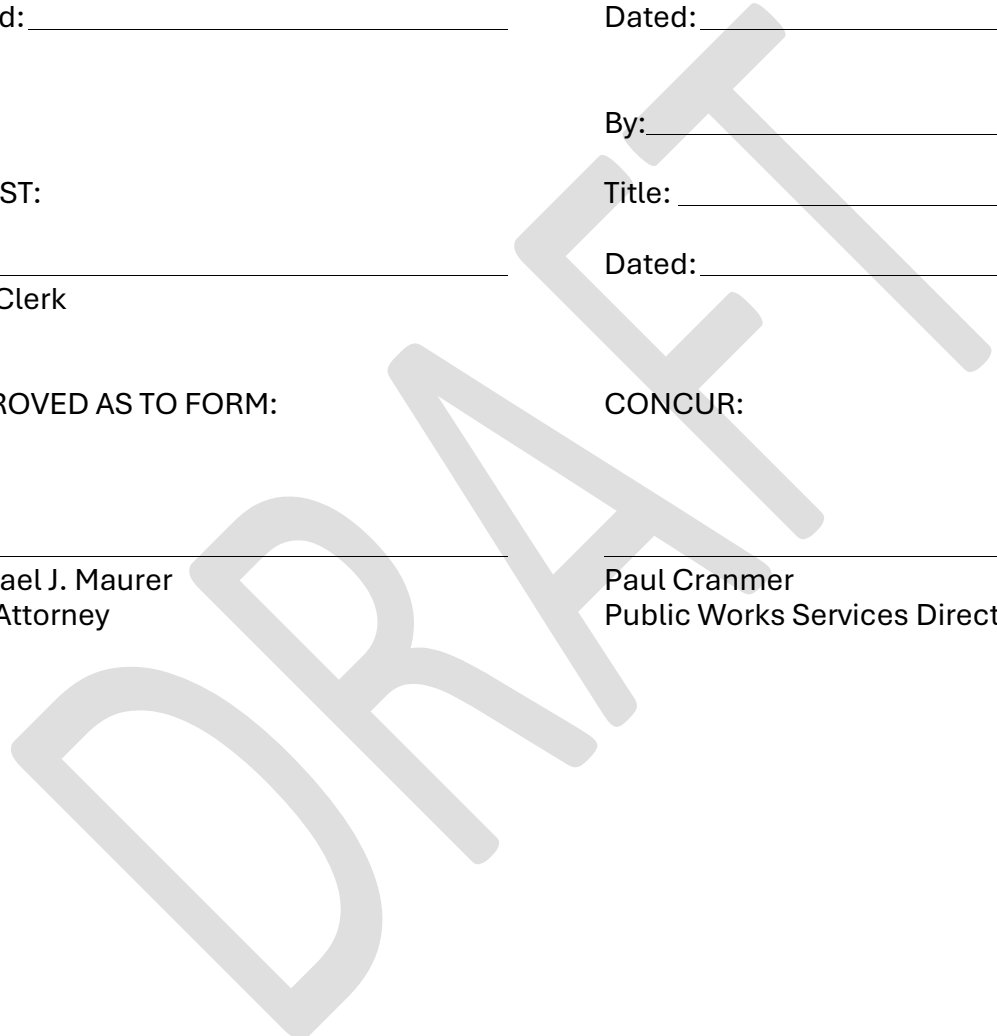

## **Exhibit "A"** **Scope of Services**

The Additional Scope of Services for the Security Alarm and Fire Suppression System Installation, Monitoring, and Repair Services and Security Camera and Access Control Upgrade and Installation, are hereby amended to include the following:

### **Amendment 2 — Scope of Services**

#### **Upper City Hall**

- 1 Keypad access control for exterior basement door + run
- Fire alarm troubleshooting and re-wiring for communication issues (basement mechanical room duct detector)
- Fire suppression repairs: faded Backflow Control and Main Drain signs; install coverage for 4' wide ducts in basement

#### **Lower City Hall**

- Fire suppression repairs: faded Backflow Control and Main Drain signs

#### **Community Center & Recreation Building**

- New Fire Alarm System — remove existing Bosch Radionics FACP and all devices; install new N16E FACP with new wireless devices, smoke detectors, AVs, and modules; install new annunciator hardwired to panel; lifts included
- Fire suppression repairs: install missing ITV signs and valve signs; replace 12 painted cover plates and missing 401 skirt; install missing escutcheons; address oversized sprinkler head spacing in office hallway; install FDC address sign; paint backflow, FDC, and connection points red per Fire Inspector; raise Inspector's Test valve

#### **Council Chambers**

- New Fire Alarm System — remove existing Bosch Radionics Panel and replace with new NFW-50X; replace annunciator and all initiating devices (smokes, heats, pull stations, duct detectors); re-use existing wiring and notification devices; lifts included

#### **Arcadia Public Library**

- 2 Exterior Cameras + runs (bike rack and adjacent coverage area)
- Fire alarm troubleshooting — replace 12AH batteries in FACP; verify M30 point and label correction; correct M10 device description
- Fire suppression repair: replace painted standard response chrome pendent

### **Gilb Museum of Arcadia Heritage**

- 1 Wireless Panic Button + wireless hub
- New Fire Alarm System — remove existing Gamewell system and all devices; install new Notifier Fire Alarm System; re-use existing wiring; add new devices to bring building up to code; lifts included (duct detectors excluded)
- Fire suppression repairs: install missing Main Drain and Auxiliary Valve signs; install missing Backflow Control Valve Keep Open signs; replace loaded sprinkler head in office behind reception

### **Museum Education Center (MEC)**

- 1 Wireless Panic Button + wireless hub
- 1 Switch installation to lock and unlock electrified front door (hardware and labor included)
- 1 New Exterior Camera (rear of building) + run
- New Fire Alarm Control Panel — remove failing Potter FACP and annunciator; install new Potter FACP and annunciator (1-for-1 swap); re-use existing wiring; lifts included
- Fire suppression repairs: replace faded Backflow Control signs; install missing Tyco escutcheons in storage rooms (103 and 102 sides)

### **Fire Station 105**

- Fire alarm troubleshooting — repair SLC circuit short; locate and replace missing smoke detectors; repair or replace main lobby and hallway devices; perform partial system testing and verify communication
- Fire suppression repair: retest supervisory devices and water flow reporting to panel

### **Fire Station 106**

- 4 Exterior Cameras + runs (flagpole area, secondary front entrance, and rear gate)

### **Fire Station 107**

- Fire alarm troubleshooting — replace OSY West Side Switch (Potter OSYSU-2) and verify communication to FACP; inspect and test duct detector (D4120); verify proper operation during testing

### **Public Works**

- 2 Exterior Cameras + runs (yard coverage)
- 1 New Access Control (Front Office Door) — Verkada multi-format card reader with keypad + door license + cabling
- New Fire Alarm System — remove existing panel and devices; install new panel, annunciator, smokes, heats, pull stations, and duct detectors; re-use existing wiring and notification devices; lifts included

- Fire suppression repairs: install two missing bell signs on West building (north and west sides); replace faded ITV sign at East building car wash; install lock on street-access PIV

### **Police Department**

- Re-wire 53 existing cameras due to incompatible legacy coaxial extensions on CAT5 wiring (27 cameras in the jail and 23 cameras around the exterior of the Police Department facility, plus 3 covert cameras to be installed in interview rooms)
- 3 Outdoor Two-Camera Multisensor Cameras (Verkada CY63) + licenses, mounts, and runs
- 7 Outdoor Four-Camera Multisensor Cameras (Verkada CH53) + licenses, mounts, and runs
- Outdoor electrical boxes for two camera locations; conduit work for two of the four-lens camera locations; black-pipe pole installation for two additional camera locations (cinderblock wall mounting)
- 1 Additional Viewing/Monitoring Station + license, cabling, and installation (location: Police Department)
- 2 Video Intercom Keypads (Verkada TD63) + licenses
- Fire alarm — install (1) UDACR2 at the FACP to enable monitoring; verify proper installation, wiring, and communication with the monitoring system

### **Orange Grove Water — 67 W. Orange Grove Avenue, Arcadia, CA 91006**

- 2 Access control keypad installations (1 building door, 1 gate) — Verkada multi-format card readers with keypads + door licenses + cabling
- 1 4-Door Controller (Verkada AC42) + 4AH backup battery (utilizing existing PD inventory)
- Access control Verkada conversion installation (replacement of existing standalone access control system)
- 3 Exterior Two-Camera Multisensor Cameras + licenses (main entrance, rear of buildings, and far side behind water tanks)
- 1 Single-Lens Dome Camera + pole mount (utilizing existing PD inventory)
- Mounting hardware: 1 arm mount, 1 pendant cap, 2 pole mounts
- 5 Point-to-multipoint wireless solutions (airMAX NanoStation 5AC) to connect remote location and gate to network
- 4 8-Port Switches
- 1 24-Port Layer 3 Managed Network Switch (Ubiquiti USW-Pro-24-POE) + Unify Cloud Gateway + installation and switch configuration
- Cellular Gateway Solution for Dome Camera (Verkada GC31) + cellular gateway data plan and license
- Bucket truck for solar installation (2 weeks)

**END OF SECTION**

**Exhibit "B"**  
**Schedule of Charges/Payments**

For the term of the **Agreement dated October 14, 2025**, the **additional Compensation under Amendment No. 2** shall not to exceed the total amount listed below:

Security Alarm and Fire Suppression System Installation, Monitoring, and Repair Services and Security Camera and Access Control Upgrade and Installation	-	\$384,398.38
---	---	--------------

<b>Total Additional Compensation</b>	-	<b>\$384,398.38</b>
--------------------------------------	---	---------------------

The total compensation shall not exceed the total listed without written authorization in accordance with Section 2 (b) of the Agreement.

DRAFT

**DATE:** June 16, 2026

**TO:** Honorable Mayor and City Council

**FROM:** Dominic Lazzaretto, City Manager  
By: Anely Williams, Human Resources Director  
Paul Cranmer, Public Works Services Director

**SUBJECT:** RESOLUTIONS TO REORGANIZE THE PUBLIC WORKS SERVICES DEPARTMENT

RESOLUTION NO. 7703 AMENDING RESOLUTION NO. 7598, ESTABLISHING COMPENSATION AND RELATED BENEFITS FOR CITY COUNCIL, EXECUTIVE MANAGEMENT, MANAGEMENT, AND UNREPRESENTED CONFIDENTIAL EMPLOYEES FOR JULY 1, 2024, THROUGH JUNE 30, 2027 (ASSISTANT CITY MANAGER/PUBLIC WORKS SERVICES DIRECTOR; CITY ENGINEER/DEPUTY PUBLIC WORKS SERVICES DIRECTOR; DEPUTY PUBLIC WORKS SERVICES DIRECTOR - ADMINISTRATION; UTILITIES MANAGER; DEPUTY DEVELOPMENT SERVICES DIRECTOR)

**CEQA: Not a Project**

**Recommendation: Adopt**

RESOLUTION NO. 7704 AMENDING RESOLUTION NO. 7594, APPROVING A MEMORANDUM OF UNDERSTANDING ESTABLISHING COMPENSATION AND RELATED BENEFITS FOR EMPLOYEES REPRESENTED BY THE ARCADIA CITY EMPLOYEES' ASSOCIATION ("ACEA") FOR JULY 1, 2024, THROUGH JUNE 30, 2027 (ARBORIST)

**CEQA: Not a Project**

**Recommendation: Adopt**

## **SUMMARY**

After 19 years of dedicated service to the City, Arcadia's Assistant City Manager/Development Services Director retired in December 2025. As with any significant change in staffing, current industry trends, customer service needs, and staffing models were evaluated to identify potential operating efficiencies and economies of scale.

As a result of this review, the City Manager is proposing to reorganize the Public Works Services Department's ("PWSD") staffing model, modernize job descriptions, and better distribute workloads. The proposed modifications include combining and integrating the engineering section of the Development Services Department ("DSD") with the PWSD engineering section, realigning the roles and responsibilities of the Public Works Services Director, Deputy Public Works Services Director, Deputy Development Services Director, and City Engineer, as well as the creation of a new Arborist position. The Public Works Services Director would then be appointed as the Assistant City Manager/Public Works Services Director to reflect the increased responsibilities and would serve as the top administrator in the City in the absence of the City Manager.

The intent of this reorganization, updated classification specifications, and creation of a new position is meant to better distribute workloads, ensure continuity of service, improve service to the community, and expand functions. The total fiscal impact of the proposed reorganization in Fiscal Year 2026-27 will be \$193,457. Changes to the salary schedule, such as adding a newly created position, revising position titles, or revising salary ranges, must be adopted publicly in accordance with the California Public Employees' Retirement System ("CalPERS").

Accordingly, to ensure successful implementation of the proposed PWSD reorganization and maintain compliance with CalPERS requirements, it is recommended that the City Council adopt Resolution No. 7703 amending Resolution No. 7598, establishing compensation and related benefits for City Council, Executive Management, Management, and Unrepresented Confidential employees for July 1, 2024, through June 30, 2027 (Assistant City Manager/Public Works Services Director; City Engineer/Deputy Public Works Services Director; Deputy Public Works Services Director - Administration; Utilities Manager; Deputy Development Services Director); and Resolution No. 7704 amending Resolution No. 7594, approving a Memorandum

of Understanding establishing compensation and related benefits for employees represented by the Arcadia City Employees' Association ("ACEA") for July 1, 2024, through June 30, 2027 (Arborist).

## **BACKGROUND**

After 19 years of dedicated service to the City, Arcadia's Assistant City Manager/Development Services Director retired in December 2025. At the time of retirement, the City conducted a recruitment process to fill the vacancy. To secure a broad candidate pool, interested individuals were invited to apply for either the Development Services Director level or the Assistant City Manager/Development Services Director level, depending on qualifications. At the conclusion of the recruitment process, an internal candidate was promoted to the Development Services Director position.

Although the Development Services Director vacancy was filled through the recruitment process, one of the existing Department Directors must now be appointed to fulfill the Charter's City Manager Pro Tempore requirement. Specifically, the Arcadia City Charter Section 603 requires the City Manager to appoint, subject to the approval of the City Council, a City Manager Pro Tempore.

## **DISCUSSION**

### **Assistant City Manager/Public Works Services Director**

In accordance with the City Charter, a Department Director must be appointed by the City Manager, subject to the approval of the City Council, to fulfill the City Manager Pro Tempore requirement.

After several discussions and evaluation of the Assistant City Manager role, the City Manager has determined that the Public Works Services Director is the most qualified to perform the duties of the Assistant City Manager. The Public Works Services Director oversees critical services and provides highly responsive service to the community. Specifically, the Public Works Services Department ("PWSD") consists of 67 full-time employees that are responsible for the care and maintenance of all City owned facilities, equipment, and infrastructure. The PWSD is also responsible for

the planning and implementation of numerous projects included in the City's Capital Improvement Program. The PWSD is comprised of four operating divisions:

1. The Administrative Division includes customer services, engineering, and environmental services;
2. The General Services Division encompasses facility maintenance and repair services, traffic signal/street light repair, and fleet services for servicing City vehicles;
3. The Streets Division handles City owned trees and streets services; and
4. The Utilities Division is responsible for Arcadia's water and sewer system.

With responsibility over such expansive and critical services, the Public Works Services Director is well equipped to rise to the level of Assistant City Manager. With this appointment, the Public Works Services Director will become Assistant City Manager/Public Works Services Director and will provide highly responsible and complex strategic and administrative support to the City Manager and may serve as Acting City Manager in the absence of the City Manager. The position is meant to provide leadership for the development and implementation of City policies and overall operation of the City through direct support and guidance of City departments. With the appointment of the Public Works Services Director to Assistant City Manager/Public Works services Director, the previous title of Assistant City Manager/Development Services Director will be removed from the salary schedule.

Effective in Fiscal Year 2026-27, the Assistant City Manager/Public Works Services Director salary will increase from \$16,920/month - \$20,125/month to \$19,942/month - \$24,905/month in order to compensate the position at a level that is commensurate with the role and responsibilities.

### **Proposed Combined Engineering Section**

For many decades, there have been two Engineering Sections within the City; one in the DSD and the other in the PWSD:

- The Engineering Section of the DSD currently handles onsite plan check review for all new developments, arterial street improvements, the traffic signal network, and transportation and traffic control.

- The Engineering Section in the PWSD performs offsite plan check review for all new developments, residential street improvements (which include pavement rehabilitation and slurry seal), water permitting for all residential/commercial developments, and water, sewer, and stormdrain infrastructure improvements.

It has been determined that combining the two Engineering Sections under the PWSD will allow for increased efficiency in service delivery through a more streamlined approach, coordinated efforts, and reduced ambiguity over responsibilities.

Currently, there are four division managers in the PWSD that report to the Deputy Public Works Services Director, with oversight from the Public Works Services Director (See Attachment No. 1 PWSD Organizational Chart).

With the proposed appointment of the Public Works Services Director to Assistant City Manager/Public Works Services Director, the City Manager is proposing to reorganize the PWSD staffing model, modernize job descriptions, and better distribute workloads.

The proposed modifications include combining and integrating the engineering section of the DSD with the PWSD engineering section, realigning roles and responsibilities of the PWS Director, Deputy PWS Director, City Engineer, and Deputy Development Services Director, and the creation of a new Arborist position. The intent of this reorganization, updated employee classification specifications, and creation of a new position are meant to better distribute workloads, improve customer service, and expand functions.

Currently, the Deputy Development Services Director in the DSD has functional responsibilities in guidance and oversight of the DSD Engineering Section. The DSD Engineering Section is led by the City Engineer. The City Engineer in the DSD currently oversees a Transportation Services Manager, Senior Administrative Assistant, Principal Civil Engineer, Associate Civil Engineer, and Assistant Engineer (See Attachment No. 2 DSD Organizational Chart). Under the proposed reorganization, the Engineering Section in the DSD would be combined with, and integrated into, the PWSD Engineering Section. Therefore, the listed positions will be integrated into the

PWSD Engineering Section, except for the Deputy Development Services Director, the Transportation Services Manager, and Senior Administrative Assistant, which will remain with DSD.

As a result of this reorganization, several related changes will be necessary to effectively integrate sections and distribute workload across all functional areas:

**Deputy Development Services Director.** Once the DSD Engineering Section is combined and integrated into the PWSD Engineering Section, the Deputy Development Services Director will no longer have any functional responsibilities over Engineering staff. With such a significant change, and since the position is currently vacant, it is proposed for the salary range to be reduced from \$14,606/month - \$18,241/month to \$13,951/ month - \$17,423/month, effective in Fiscal Year 2026-27. The proposed reduced salary aligns with the current Deputy Public Works Services Director and the newly proposed City Engineer/Deputy Public Works Services Director's salary, which are discussed in further detail below.

**City Engineer/Deputy Public Works Services Director.** Upon combining the two Engineering Sections, the City Engineer will become the City Engineer/Deputy Public Works Services Director. The position will oversee the entire, combined Engineering Section and the Streets Section of the PWSD. Since the Streets Section is responsible for dealing with street improvements, it is a natural transition for the City Engineer/Deputy Public Works Services Director to oversee this entire section. In the Engineering Section, there will be two Principal Civil Engineers. One will be responsible for street related projects and the other for water and sewer related projects. With the two Engineering Sections combined, work will be completed more efficiently and timely. Combining both Engineering Sections will streamline workflows and provide staff with more time to complete projects that continue to be deferred.

In recognition of the increased responsibility and scope of work for the City Engineer/Deputy Public Works Services Director, a 5% increase in salary from a range of \$13,279 - \$16,583/month to \$13,951 - \$17,423/month is recommended, effective in Fiscal Year 2026-27. Additionally, this salary aligns with the current Deputy Public Works Services Director's salary, which ensures parity for equivalent positions.

**Deputy Public Works Services Director - Administration.** Currently, the Deputy Public Works Service Director is responsible for all divisions of the Public Works Services Department, with engineering support from the Public Works Services Director. The proposed reorganization will change the Deputy Public Works Services Director title to Deputy Public Works Services Director - Administration. The Deputy Public Works Services Director - Administration will oversee the Customer Service Section, Environmental Services Section, and General Services Section, which includes facility maintenance, traffic signal/streetlight, and fleet services. The streamlined distribution of work will help balance workload and will result in greater operational efficiency for the community.

Although the proposed organizational change will remove Engineering oversight from the Deputy Public Works Services Director - Administration, there is no proposed change to the salary range for this incumbent and the position. Therefore, there is no fiscal impact with this title change. Maintaining the existing salary ensures parity with equivalent positions in both DSD and PWSD. Although there is no change in salary, any change to the salary schedule, such as a title change to Deputy Public Works Services Director - Administration, must be adopted publicly in accordance with CalPERS.

**Utilities Manager.** The Utilities Section will continue to be managed by the Utilities Manager. However, as part of the proposed changes, the Utilities Manager will report directly to the Assistant City Manager/Public Works Services Director. Additionally, the Utilities Manager will begin to oversee larger scale utility engineering projects and will have an additional engineering employee within the section. Given the critical nature of the Utilities Manager job requirements, and with the additional responsibilities, it is recommended to provide a 5% salary increase from a range of \$12,682 - \$15,839/month to \$13,279 - \$16,583/month, effective in Fiscal Year 2026-27.

**New Arborist Position.** Although the City utilizes a contractor to assist with the maintenance of the City's Urban Forest, the new staffing model is proposing to add a new Arborist position to the PWSD. An Arborist would benefit the City as this position would manage, maintain, and protect tree assets by creating and managing an Urban Forest Master Plan. An Urban Forest Master Plan is a long-term strategic roadmap designed to guide the growth, preservation, and maintenance of a City's trees and green spaces. The dedicated Arborist position would assist in risk

mitigation by performing hazard assessments, disease control, and assessing trees for hazards, as well as providing inventories of tree species, maintaining a Master Plan for long-term maintenance, urban forestry, and infrastructure protection. Most importantly, following major storm events, the City would have an in-house Arborist that is able to inspect trees and take the lead in determining the removal of dangerous or damaged trees.

While the PWSD has utilized the Streets Superintendent to assist with inspecting trees and managing the City's Tree Trimming Contract, the Streets Superintendent job classification specification does not include the need for the Streets Superintendent to have an Arborist Certification. The Streets Superintendent is meant to focus on street improvements, curb/sidewalk repairs, street signs, street cleaning, and illicit dumping/cleanup efforts. However, since the Streets Superintendent held and maintained an Arborist Certification, the incumbent has assisted with the City's Arborist needs for many years. The Streets Superintendent should be able to focus solely on street improvements and repairs. Thus, creating an Arborist position will allow the Streets Superintendent to develop and maintain a Street Improvement Master Plan among other needed improvements. The new Arborist position will require an Arborist Certification and the position will focus exclusively on diagnosing trees for diseases, pests, ensuring that tree removal or pruning of trees complies with environmental regulations, and managing the City's current tree and landscape contract.

A salary survey of surrounding cities was conducted to determine the market rate for this position. Therefore, the proposed Arborist position will be placed in Salary Range 56 which ranges from \$6,027/month - \$7,525/month. The proposed Arborist position and salary range have already been discussed with the Arcadia City Employees' Association, where this new position would be placed.

As part of this reorganization, the PWSD office building will need to be remodeled. Already included as part of the FY23-24 Capital Improvement Plan is the design for the PWSD Office reconfiguration. The PWSD is working on preparing a Request for Proposals for an architectural firm to design a more secure PWSD facility and design/reconfigure the PWSD facility to adequately provide sufficient office space. The PWSD will present the architectural plans when completed and request a budget for construction at that time.

Overall, the proposed Public Works Services Department reorganization will lead to streamlined processes, reduced ambiguity for both staff and the community, and a better distribution of workloads.

The updated job descriptions and salary schedules to reflect the proposed changes are attached to this staff report.

**ENVIRONMENTAL ANALYSIS**

The proposed action does not constitute a project under the California Environmental Quality Act (“CEQA”), based on Section 15061(b)(3) of the CEQA Guidelines, as it can be seen with certainty that it will have no impact on the environment.

**FISCAL IMPACT**

The total additional cost associated with the appointment of the Public Works Services Director to Assistant City Manager/Public Works Services Director as well as the proposed reorganization is \$193,457 in Fiscal Year 2026-27, as shown below:

<b>Position</b>	<b>Additional Cost / (Savings)</b>
Assistant City Manager/Public Works Services Director	\$ (20,056)
Deputy Development Services Director	\$ (13,239)
City Engineer/Deputy Public Works Services Director	\$ 13,073
Deputy Public Works Services Director - Administration	\$ 0
Utilities Manager	\$ 11,579
Arborist (new)	\$ 202,100
<b>TOTAL</b>	<b>\$ 193,457</b>

These additional costs were already included as part of the Fiscal Year 2026-27 operating budget. Therefore, no additional appropriation is needed. It is important to note that although the appointment of the Public Works Services Director to Assistant City Manager/Public Works Services Director is proposed with an increase to the salary range, the overall cost of the position is less than the cost of the previous Assistant City Manager/Development Services Director. Therefore, the delta between both positions would have resulted in overall savings of \$20,056. Without including

the Arborist position, the net cost of proposed reorganization would be a savings of \$8,643 annually.

The Arborist position would be requested even without the reorganization and is only shown here to effectuate the request in the budget. The cost shown above for the new Arborist position was added to the Fiscal Year 2026-27 Operating Budget as a New Program, which included a total salary and benefits cost of \$135,800 and a one-time cost of \$66,300 for a new vehicle. Therefore, future year costs will be reduced for this position.

### **RECOMMENDATION**

It is recommended that the City Council determine that this action is not a project under the California Environmental Quality Act ("CEQA"); and adopt Resolution No. 7703 amending Resolution No. 7598, establishing compensation and related benefits for City Council, Executive Management, Management, and Unrepresented Confidential employees for July 1, 2024, through June 30, 2027 (Assistant City Manager/Public Works Services Director; City Engineer/Deputy Public Works Services Director; Deputy Public Works Services Director - Administration; Utilities Manager; Deputy Development Services Director); and Resolution No. 7704 amending Resolution No. 7594, approving a Memorandum of Understanding establishing compensation and related benefits for employees represented by the Arcadia City Employees' Association ("ACEA") for July 1, 2024, through June 30, 2027 (Arborist).

Attachment No. 1: PWSD Current and Proposed Organizational Chart

Attachment No. 2: DSD Current and Proposed Organizational Chart

Attachment No. 3: Resolution No. 7703 (includes salary schedules as Exhibit "A")

Attachment No. 4: Resolution No. 7704 (includes salary schedules as Exhibit "A")

Attachment No. 5: Revised Job Descriptions

CURRENT

# PUBLIC WORKS SERVICES DEPARTMENT

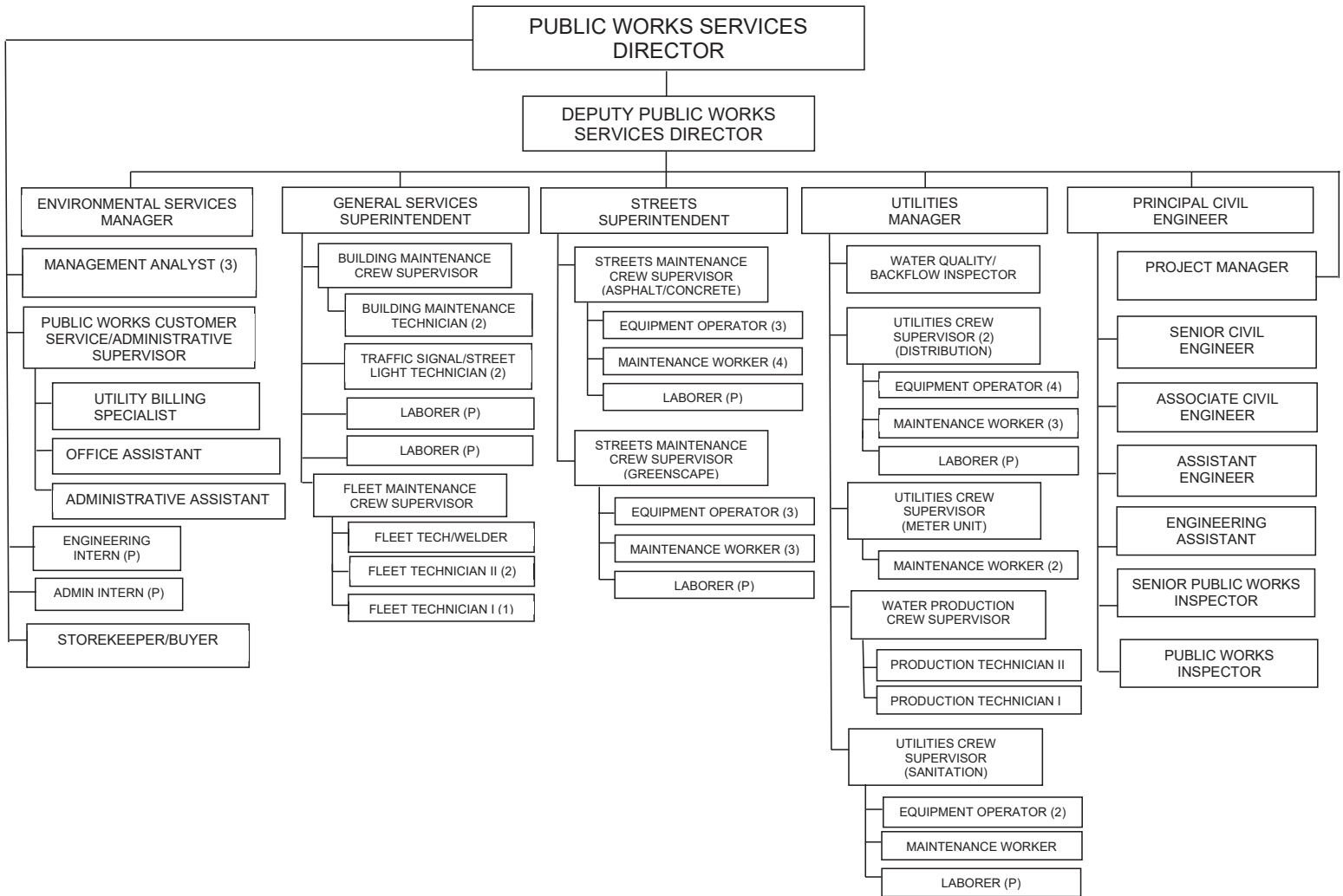

**PROPOSED**

# **PUBLIC WORKS SERVICES DEPARTMENT**

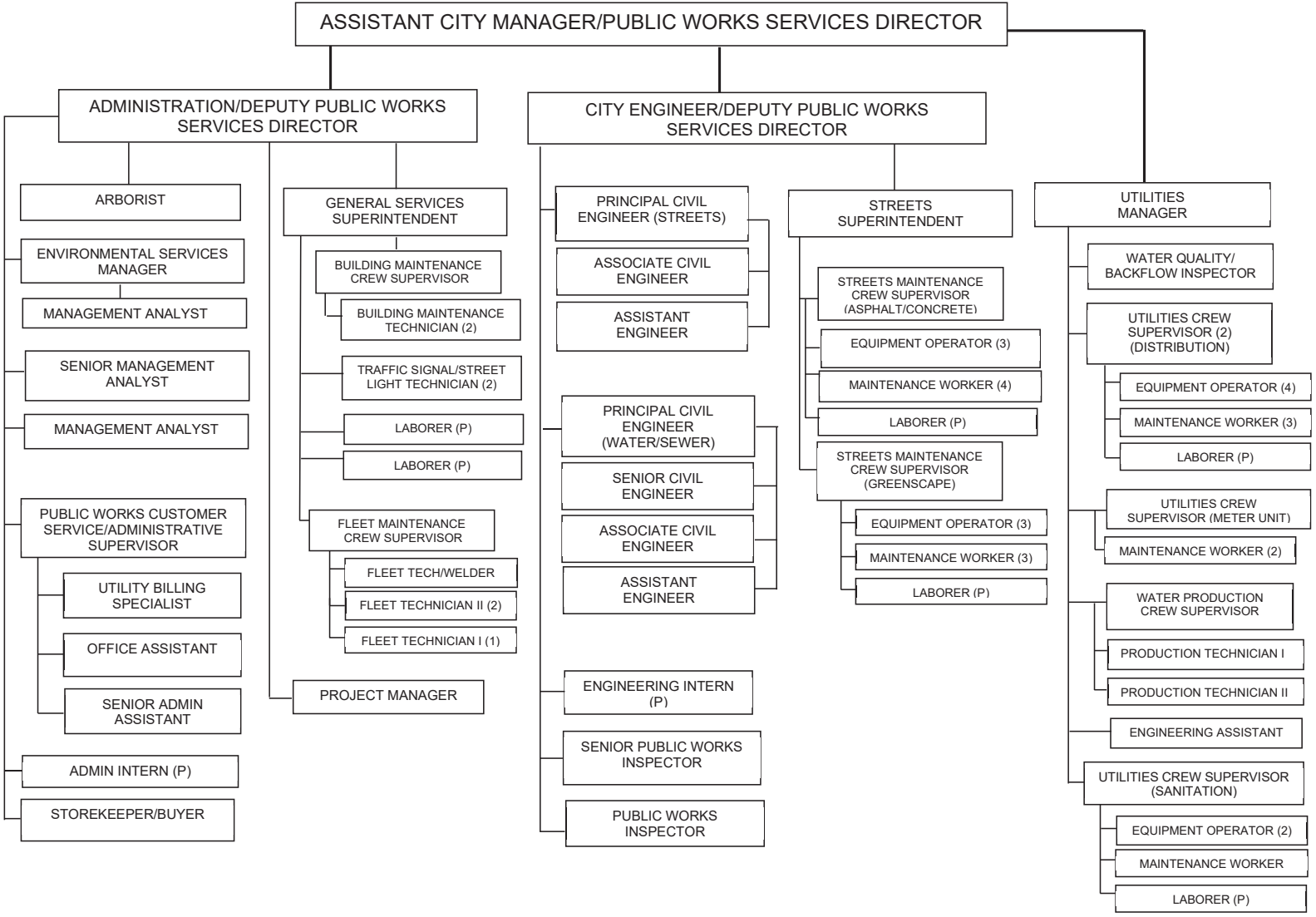

CURRENT

# DEVELOPMENT SERVICES DEPARTMENT

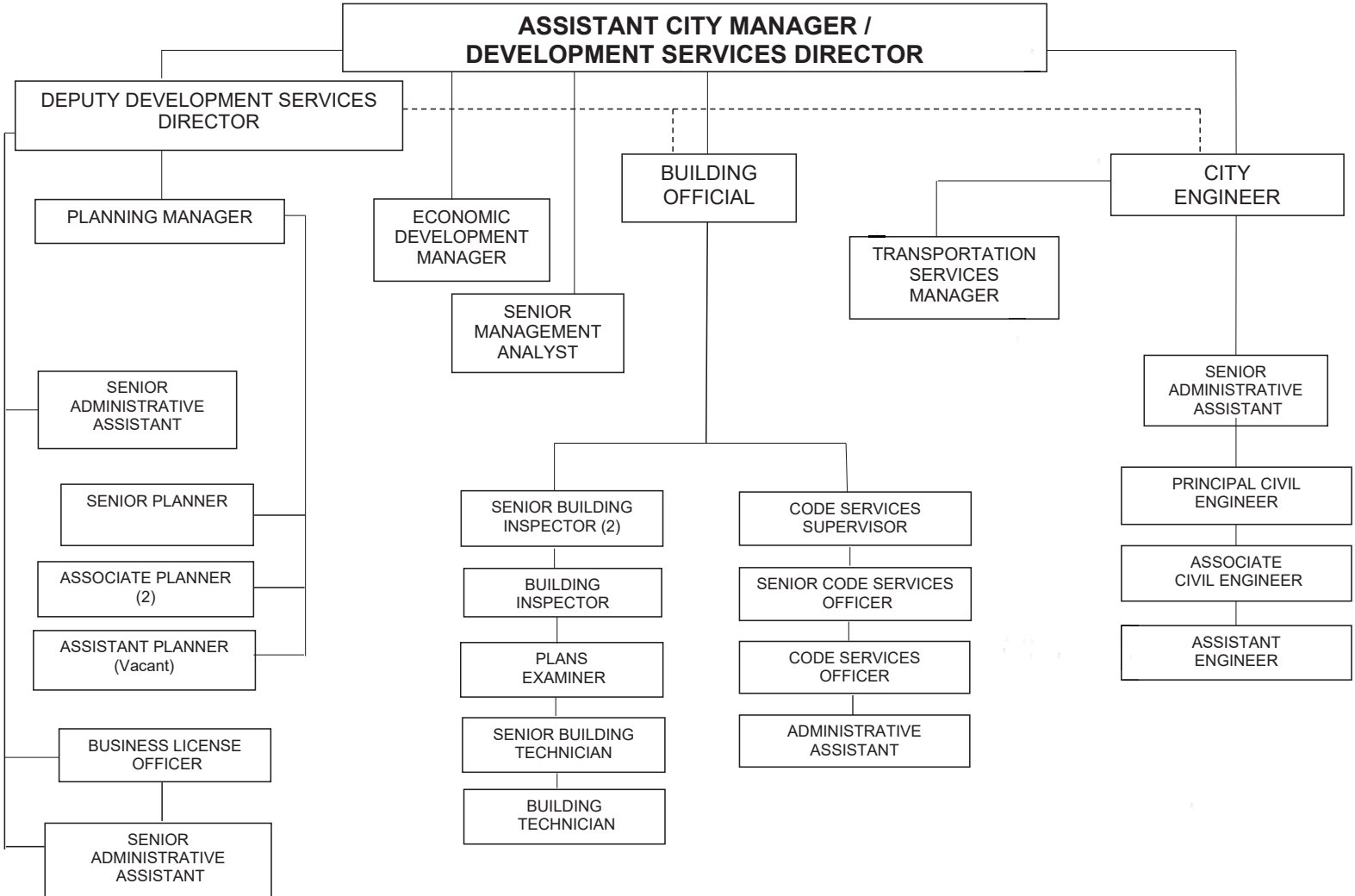

**PROPOSED**

# DEVELOPMENT SERVICES DEPARTMENT

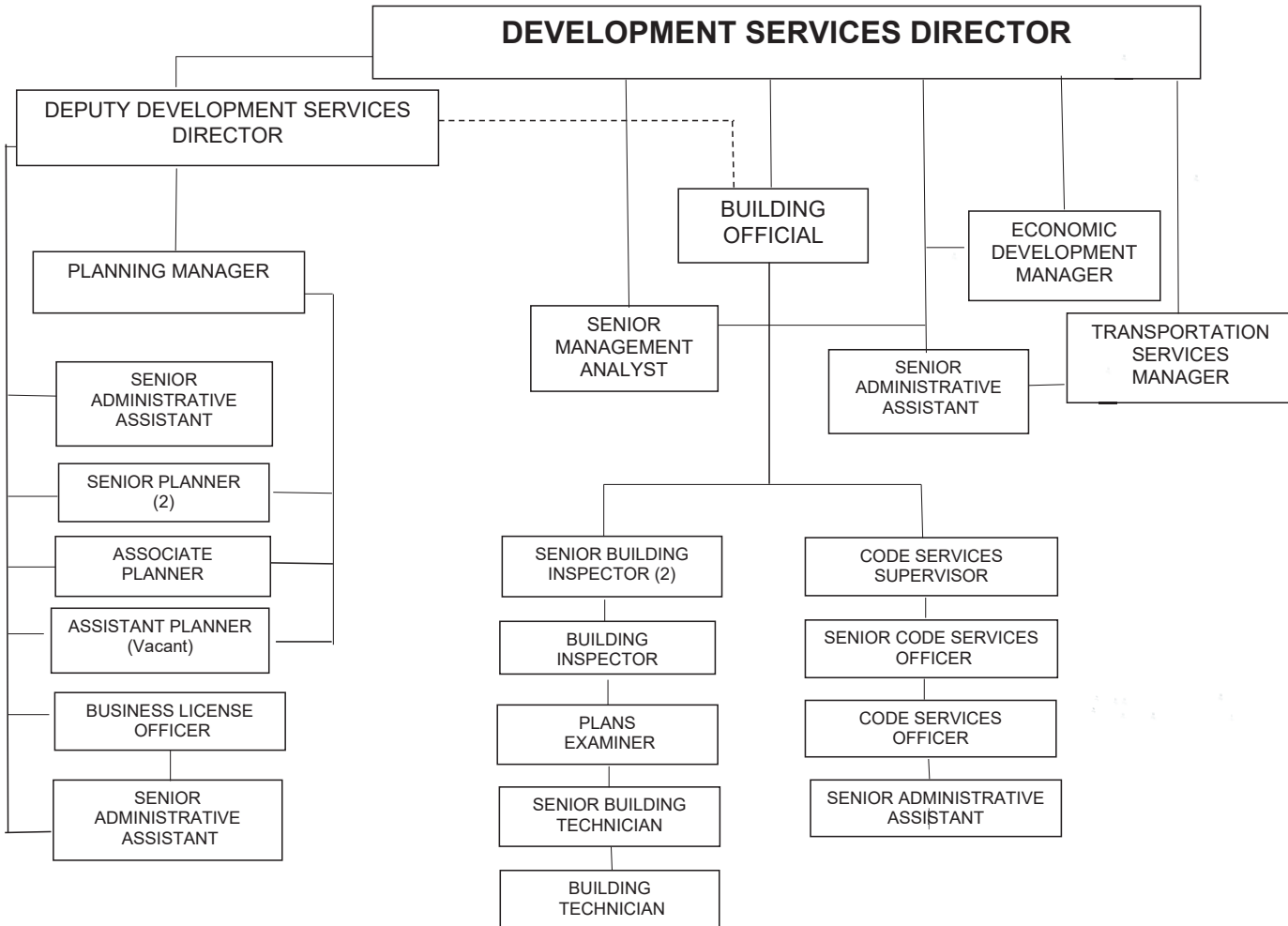

**Attachment No. 3**

RESOLUTION NO. 7703

A RESOLUTION OF THE CITY COUNCIL OF THE CITY OF ARCADIA, CALIFORNIA, AMENDING RESOLUTION NO. 7598, ESTABLISHING COMPENSATION AND RELATED BENEFITS FOR CITY COUNCIL, EXECUTIVE MANAGEMENT, MANAGEMENT, AND UNREPRESENTED CONFIDENTIAL EMPLOYEES FOR JULY 1, 2024, THROUGH JUNE 30, 2027 (ASSISTANT CITY MANAGER/PUBLIC WORKS SERVICES DIRECTOR; CITY ENGINEER/DEPUTY PUBLIC WORKS SERVICES DIRECTOR; DEPUTY PUBLIC WORKS SERVICES DIRECTOR - ADMINISTRATION; UTILITIES MANAGER; DEPUTY DEVELOPMENT SERVICES DIRECTOR)

WHEREAS, City Council Resolution 7598 approved various fringe benefits and related compensation for officials, officers, and management of the City; and

WHEREAS, Section 38 of Resolution No. 7598 provides for amendment and modification by City Council approved resolutions that direct inclusion of any changes as part of said Resolution; and

WHEREAS, salaries and benefits for City Council, Executive Management, Management, and Unrepresented Confidential Employees that are adjusted by resolution are then reflected on the City's salary schedule; and

WHEREAS, salary schedules are adopted publicly in accordance with Government Code Section 20636 and Title 2 of the California Code of Regulations Section 570.5 and as required by the California Public Employees' Retirement System ("CalPERS").

NOW THEREFORE THE CITY COUNCIL OF THE CITY OF ARCADIA, CALIFORNIA DOES HEREBY FIND, DETERMINE AND RESOLVE AS FOLLOWS:

SECTION 1. Effective upon the beginning of the pay period containing July 1, 2026 (June 28, 2026), the City Council hereby publicly approves the salary schedules as set forth in Exhibit "A", attached hereto, which incorporate the modifications of the Assistant City Manager/Public Works Services Director; City Engineer/Deputy Public Works Services Director; Deputy Public Works Services Director-Administration; Utilities Manager; and Deputy Development Services Director.

SECTION 2. The City Council hereby approves the updated salary schedules to Resolution No. 7598 as set forth in the City of Arcadia Fringe Benefits Resolution as attached hereto, effective as of July 1, 2024, through June 30, 2027.

SECTION 3. This Resolution shall become effective upon its adoption.

SECTION 4. The City Clerk shall certify to the adoption of this Resolution.

[SIGNATURES ON THE NEXT]

Passed, approved, and adopted this 16th day of June, 2026.

\_\_\_\_\_  
Mayor of the City of Arcadia

ATTEST:

\_\_\_\_\_  
City Clerk

APPROVED AS TO FORM:

  
\_\_\_\_\_  
Michael J. Maurer  
City Attorney

**EXHIBIT A  
CITY OF ARCADIA MONTHLY SALARY RANGE  
JULY 1, 2026 - JUNE 30, 2027**

**EXECUTIVE MANAGEMENT**

Title	Step A	Step B	Step C	Step D	Step E	Step F	Step G	Step H	Step I	Step J
Administrative Services Director	\$ 16,636	\$ 17,050	\$ 17,479	\$ 17,916	\$ 18,365	\$ 18,822	\$ 19,292	\$ 19,774	\$ 20,273	\$ 20,776
<del>Assistant City Manager/ Development Services Director</del>	<del>\$ 20,974</del>	<del>\$ 21,499</del>	<del>\$ 22,036</del>	<del>\$ 22,587</del>	<del>\$ 23,152</del>	<del>\$ 23,730</del>	<del>\$ 24,324</del>	<del>\$ 24,932</del>	<del>\$ 25,555</del>	<del>\$ 26,194</del>
Development Services Director	\$ 16,920	\$ 17,343	\$ 17,777	\$ 18,221	\$ 18,676	\$ 19,144	\$ 19,622	\$ 20,113	\$ 20,616	\$ 21,131
Director of Library & Museum Services	\$ 16,636	\$ 17,050	\$ 17,479	\$ 17,916	\$ 18,365	\$ 18,822	\$ 19,292	\$ 19,774	\$ 20,273	\$ 20,776
Director of Recreation & Community Services	\$ 16,636	\$ 17,050	\$ 17,479	\$ 17,916	\$ 18,365	\$ 18,822	\$ 19,292	\$ 19,774	\$ 20,273	\$ 20,776
Human Resources Director	\$ 16,636	\$ 17,050	\$ 17,479	\$ 17,916	\$ 18,365	\$ 18,822	\$ 19,292	\$ 19,774	\$ 20,273	\$ 20,776
<del>Public Works Services Director</del>	<del>\$ 16,920</del>	<del>\$ 17,343</del>	<del>\$ 17,777</del>	<del>\$ 18,221</del>	<del>\$ 18,676</del>	<del>\$ 19,144</del>	<del>\$ 19,622</del>	<del>\$ 20,113</del>	<del>\$ 20,616</del>	<del>\$ 21,131</del>
Assistant City Manager/Public Works Services Director	\$ 19,942	\$ 20,441	\$ 20,952	\$ 21,476	\$ 22,012	\$ 22,563	\$ 23,127	\$ 23,705	\$ 24,298	\$ 24,905

**SAFETY EXECUTIVE MANAGEMENT**

Fire Chief	\$ 20,930	\$ 21,453	\$ 21,989	\$ 22,538	\$ 23,102	\$ 23,680	\$ 24,272	\$ 24,879	\$ 25,500	\$ 26,138
Police Chief	\$ 20,930	\$ 21,453	\$ 21,989	\$ 22,538	\$ 23,102	\$ 23,680	\$ 24,272	\$ 24,879	\$ 25,500	\$ 26,138

*Salaries are effective the beginning of the pay period containing July 1, 2026*

*Development Services Director added and approved October 7, 2025*

*Assistant City Manager/Public Works Services Director added and approved June 16, 2026, effective pay period containing July 1, 2026*

**EXHIBIT A  
CITY OF ARCADIA MONTHLY SALARY RANGE  
JULY 1, 2026 - JUNE 30, 2027  
MANAGEMENT**

Title	Step A	Step B	Step C	Step D	Step E	Step F	Step G	Step H	Step I	Step J
Accountant	\$ 7,364	\$ 7,554	\$ 7,736	\$ 7,928	\$ 8,129	\$ 8,333	\$ 8,540	\$ 8,757	\$ 8,973	\$ 9,198
Accounting Supervisor	\$ 9,905	\$ 10,154	\$ 10,409	\$ 10,666	\$ 10,934	\$ 11,210	\$ 11,487	\$ 11,774	\$ 12,069	\$ 12,371
Assistant to the City Manager	\$ 10,666	\$ 10,934	\$ 11,210	\$ 11,487	\$ 11,774	\$ 12,069	\$ 12,371	\$ 12,682	\$ 12,998	\$ 13,322
Building Official	\$ 13,279	\$ 13,611	\$ 13,951	\$ 14,300	\$ 14,657	\$ 15,024	\$ 15,399	\$ 15,784	\$ 16,179	\$ 16,583
Buyer	\$ 6,674	\$ 6,839	\$ 7,010	\$ 7,187	\$ 7,364	\$ 7,554	\$ 7,736	\$ 7,928	\$ 8,129	\$ 8,333
City Clerk	\$ 9,426	\$ 9,663	\$ 9,905	\$ 10,154	\$ 10,409	\$ 10,666	\$ 10,934	\$ 11,210	\$ 11,487	\$ 11,774
City Engineer	<del>\$ 13,279</del>	<del>\$ 13,611</del>	<del>\$ 13,951</del>	<del>\$ 14,300</del>	<del>\$ 14,657</del>	<del>\$ 15,024</del>	<del>\$ 15,399</del>	<del>\$ 15,784</del>	<del>\$ 16,179</del>	<del>\$ 16,583</del>
City Engineer/Deputy Public Works Services Director	\$ 13,951	\$ 14,300	\$ 14,657	\$ 15,024	\$ 15,399	\$ 15,784	\$ 16,179	\$ 16,583	\$ 16,998	\$ 17,423
Communication and Engagement Officer	\$ 9,198	\$ 9,426	\$ 9,663	\$ 9,905	\$ 10,154	\$ 10,409	\$ 10,666	\$ 10,934	\$ 11,210	\$ 11,487
Crime Analyst/Investigative Support Specialist	\$ 8,333	\$ 8,540	\$ 8,757	\$ 8,973	\$ 9,198	\$ 9,426	\$ 9,663	\$ 9,905	\$ 10,154	\$ 10,409
Deputy City Manager	\$ 13,322	\$ 13,657	\$ 13,997	\$ 14,348	\$ 14,705	\$ 15,076	\$ 15,451	\$ 15,839	\$ 16,232	\$ 16,636
Deputy Development Services Director	<del>\$ 14,606</del>	<del>\$ 14,972</del>	<del>\$ 15,346</del>	<del>\$ 15,730</del>	<del>\$ 16,123</del>	<del>\$ 16,526</del>	<del>\$ 16,939</del>	<del>\$ 17,362</del>	<del>\$ 17,797</del>	<del>\$ 18,244</del>
	\$ 13,951	\$ 14,300	\$ 14,657	\$ 15,024	\$ 15,399	\$ 15,784	\$ 16,179	\$ 16,583	\$ 16,998	\$ 17,423
Deputy Director of Recreation and Community Services	\$ 13,279	\$ 13,611	\$ 13,951	\$ 14,300	\$ 14,657	\$ 15,024	\$ 15,399	\$ 15,784	\$ 16,179	\$ 16,583
Deputy Public Works Services Director - Administration	\$ 13,951	\$ 14,300	\$ 14,657	\$ 15,024	\$ 15,399	\$ 15,784	\$ 16,179	\$ 16,583	\$ 16,998	\$ 17,423
Economic Development Manager	\$ 11,774	\$ 12,069	\$ 12,371	\$ 12,682	\$ 12,998	\$ 13,322	\$ 13,657	\$ 13,997	\$ 14,348	\$ 14,705
Environmental Services Manager	\$ 9,198	\$ 9,426	\$ 9,663	\$ 9,905	\$ 10,154	\$ 10,409	\$ 10,666	\$ 10,934	\$ 11,210	\$ 11,487
Financial Services Manager/Treasurer	\$ 12,998	\$ 13,322	\$ 13,657	\$ 13,997	\$ 14,348	\$ 14,705	\$ 15,076	\$ 15,451	\$ 15,839	\$ 16,232
Fire Marshal	\$ 11,210	\$ 11,487	\$ 11,774	\$ 12,069	\$ 12,371	\$ 12,682	\$ 12,998	\$ 13,322	\$ 13,657	\$ 13,997
General Services Superintendent	\$ 10,666	\$ 10,934	\$ 11,210	\$ 11,487	\$ 11,774	\$ 12,069	\$ 12,371	\$ 12,682	\$ 12,998	\$ 13,322
Human Resources Administrator	\$ 12,998	\$ 13,322	\$ 13,657	\$ 13,997	\$ 14,348	\$ 14,705	\$ 15,076	\$ 15,451	\$ 15,839	\$ 16,232
Human Resources Analyst	\$ 8,129	\$ 8,333	\$ 8,540	\$ 8,757	\$ 8,973	\$ 9,198	\$ 9,426	\$ 9,663	\$ 9,905	\$ 10,154
Human Resources Associate	\$ 6,509	\$ 6,674	\$ 6,839	\$ 7,010	\$ 7,187	\$ 7,364	\$ 7,554	\$ 7,736	\$ 7,928	\$ 8,129
Human Resources Manager	\$ 10,666	\$ 10,934	\$ 11,210	\$ 11,487	\$ 11,774	\$ 12,069	\$ 12,371	\$ 12,682	\$ 12,998	\$ 13,322
Information Technology Manager	\$ 10,934	\$ 11,210	\$ 11,487	\$ 11,774	\$ 12,069	\$ 12,371	\$ 12,682	\$ 12,998	\$ 13,322	\$ 13,657
Library Services Manager	\$ 10,666	\$ 10,934	\$ 11,210	\$ 11,487	\$ 11,774	\$ 12,069	\$ 12,371	\$ 12,682	\$ 12,998	\$ 13,322
Management Aide	\$ 6,509	\$ 6,674	\$ 6,839	\$ 7,010	\$ 7,187	\$ 7,364	\$ 7,554	\$ 7,736	\$ 7,928	\$ 8,129
Management Analyst	\$ 8,333	\$ 8,540	\$ 8,757	\$ 8,973	\$ 9,198	\$ 9,426	\$ 9,663	\$ 9,905	\$ 10,154	\$ 10,409
Planning Services Manager	\$ 10,666	\$ 10,934	\$ 11,210	\$ 11,487	\$ 11,774	\$ 12,069	\$ 12,371	\$ 12,682	\$ 12,998	\$ 13,322
Police Records Manager	\$ 9,198	\$ 9,426	\$ 9,663	\$ 9,905	\$ 10,154	\$ 10,409	\$ 10,666	\$ 10,934	\$ 11,210	\$ 11,487
Principal Civil Engineer	\$ 12,069	\$ 12,371	\$ 12,682	\$ 12,998	\$ 13,322	\$ 13,657	\$ 13,997	\$ 14,348	\$ 14,705	\$ 15,076
Project Manager	\$ 10,409	\$ 10,666	\$ 10,934	\$ 11,210	\$ 11,487	\$ 11,774	\$ 12,069	\$ 12,371	\$ 12,682	\$ 12,998
Purchasing Officer	\$ 7,554	\$ 7,736	\$ 7,928	\$ 8,129	\$ 8,333	\$ 8,540	\$ 8,757	\$ 8,973	\$ 9,198	\$ 9,426
Recreation Supervisor	\$ 7,364	\$ 7,554	\$ 7,736	\$ 7,928	\$ 8,129	\$ 8,333	\$ 8,540	\$ 8,757	\$ 8,973	\$ 9,198
Senior Accountant	\$ 8,540	\$ 8,757	\$ 8,973	\$ 9,198	\$ 9,426	\$ 9,663	\$ 9,905	\$ 10,154	\$ 10,409	\$ 10,666
Senior Human Resources Analyst	\$ 9,198	\$ 9,426	\$ 9,663	\$ 9,905	\$ 10,154	\$ 10,409	\$ 10,666	\$ 10,934	\$ 11,210	\$ 11,487
Senior Management Analyst	\$ 9,198	\$ 9,426	\$ 9,663	\$ 9,905	\$ 10,154	\$ 10,409	\$ 10,666	\$ 10,934	\$ 11,210	\$ 11,487
Streets Superintendent	\$ 10,666	\$ 10,934	\$ 11,210	\$ 11,487	\$ 11,774	\$ 12,069	\$ 12,371	\$ 12,682	\$ 12,998	\$ 13,322
Transportation Services Manager	\$ 9,198	\$ 9,426	\$ 9,663	\$ 9,905	\$ 10,154	\$ 10,409	\$ 10,666	\$ 10,934	\$ 11,210	\$ 11,487
Utilities Manager	<del>\$ 12,682</del>	<del>\$ 12,998</del>	<del>\$ 13,322</del>	<del>\$ 13,657</del>	<del>\$ 13,997</del>	<del>\$ 14,348</del>	<del>\$ 14,705</del>	<del>\$ 15,076</del>	<del>\$ 15,451</del>	<del>\$ 15,839</del>
	\$ 13,279	\$ 13,611	\$ 13,951	\$ 14,300	\$ 14,657	\$ 15,024	\$ 15,399	\$ 15,784	\$ 16,179	\$ 16,583

Salaries are effective the beginning of the pay period containing July 1, 2026

Human Resources Associate added 04/15/2025

City Engineer/Deputy Public Works Services Director title and salary revised 06/16/2026 and effective the beginning of the pay period containing 07/01/2026

Deputy Development Services Director salary revised 06/16/2026 and effective the beginning of the pay period containing 07/01/2026

Deputy Public Works Services Director - Administration title revised 06/16/2026 and effective the beginning of the pay period containing 07/01/2026 (no change in salary)

Utilities Manager salary revised 06/16/2026 and effective the beginning of the pay period containing 07/01/2026

RESOLUTION NO. 7598

A RESOLUTION OF THE CITY COUNCIL OF THE CITY OF ARCADIA, CALIFORNIA, ESTABLISHING COMPENSATION AND RELATED BENEFITS FOR CITY COUNCIL, EXECUTIVE MANAGEMENT, MANAGEMENT, AND UNREPRESENTED CONFIDENTIAL EMPLOYEES FOR JULY 1, 2024, THROUGH JUNE 30, 2027

WHEREAS, City Council Resolution 7383 sets forth various fringe benefits and related compensation for officials, officers, and management of the City; and

WHEREAS, Section 38 of Resolution No. 7383 provides for amendment and modification by City Council approved resolutions that direct inclusion of any changes as part of said Resolution; and

WHEREAS, salaries and benefits for City Council, Executive Management, Management, and Unrepresented Confidential Employees that are adjusted by resolution are then reflected on the City's salary schedule.

NOW THEREFORE THE CITY COUNCIL OF THE CITY OF ARCADIA, CALIFORNIA DOES HEREBY FIND, DETERMINE AND RESOLVE AS FOLLOWS:

SECTION 1. The City Council hereby approves the changes to Resolution No. 7383 as set forth in the City of Arcadia Fringe Benefits Resolution as attached hereto, effective as of July 1, 2024, through June 30, 2027.

SECTION 2. The City Clerk shall certify to the adoption of this Resolution.

[SIGNATURES ON THE NEXT PAGE]

Passed, approved, and adopted this 1st day of October, 2024.

  
\_\_\_\_\_  
Mayor of the City of Arcadia

ATTEST:

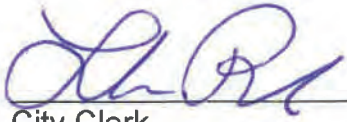
  
\_\_\_\_\_  
City Clerk

APPROVED AS TO FORM:

  
\_\_\_\_\_  
Michael J. Maurer  
City Attorney

STATE OF CALIFORNIA        )  
COUNTY OF LOS ANGELES ) SS:  
CITY OF ARCADIA            )

I, LINDA RODRIGUEZ, City Clerk of the City of Arcadia, hereby certifies that the foregoing Resolution No. 7598 was passed and adopted by the City Council of the City of Arcadia, signed by the Mayor and attested to by the City Clerk at a regular meeting of said Council held on the 1st day of October, 2024 and that said Resolution was adopted by the following vote, to wit:

AYES:        Cheng, Wang, and Cao

NOES:        Verlato, and Kwan

ABSENT:     None

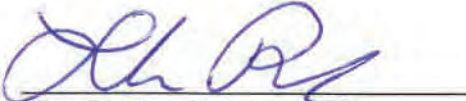
  
\_\_\_\_\_  
City Clerk of the City of Arcadia

# **CITY OF ARCADIA**

## **FRINGE BENEFITS RESOLUTION**

**CITY COUNCIL, EXECUTIVE MANAGEMENT,  
MANAGEMENT, AND UNREPRESENTED EMPLOYEES  
OF THE CITY OF ARCADIA**

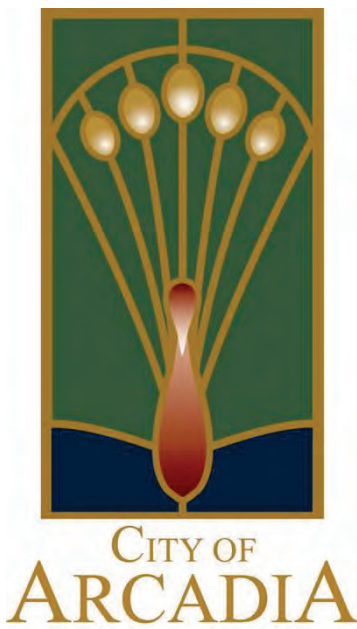

**JULY 1, 2024 – JUNE 30, 2027**

**CONTENTS**

SECTION 1. PURPOSE..... 4

SECTION 2. DEFINITIONS ..... 4

SECTION 3. COMPENSATION ..... 6

    A. BASE SALARIES AND ONE-TIME BONUS..... 6

    B. BILINGUAL PAY ..... 6

SECTION 4. SALARY STEP ADVANCEMENT ..... 6

SECTION 5. PROMOTIONAL STEP ADVANCEMENT ..... 7

SECTION 6. OVERTIME ..... 8

SECTION 7. RETIREMENT ..... 8

    A. EMPLOYEES HIRED BEFORE JULY 1, 2011 ..... 8

    B. EMPLOYEES HIRED ON OR AFTER OCTOBER 9, 2011, OTHER THAN NEW CALPERS MEMBERS HIRED AFTER JANUARY 1, 2013... 10

    C. NEW CALPERS MEMBERS HIRED ON OR AFTER JANUARY 1, 2013 12

    D. DEFERRED COMPENSATION..... 13

SECTION 8. SPECIAL ASSIGNMENT PAY ..... 13

SECTION 9. LONGEVITY PAY..... 13

SECTION 10. ACTING PAY..... 14

SECTION 11. TUITION ADVANCEMENT/REIMBURSEMENT ..... 14

SECTION 12. UNIFORMS ..... 15

SECTION 13. AUTO ALLOWANCE ..... 16

SECTION 14. MILEAGE REIMBURSEMENT ..... 16

SECTION 15. BENEFIT ALLOWANCE FOR HEALTH, DENTAL, AND VISION ..... 16

    A. CONTRIBUTION FOR EMPLOYEES HIRED BEFORE OCTOBER 1, 2024 ..... 16

    B. CONTRIBUTION FOR EMPLOYEES HIRED ON OR AFTER OCTOBER 1, 2024 ..... 18

    C. CASH IN LIEU OF COVERAGE OR CASH FOR EXCESS CONTRIBUTIONS ..... 19

SECTION 16. LIFE INSURANCE ..... 20

SECTION 17. LONG TERM DISABILITY INSURANCE ..... 20

SECTION 18. RETIREE HEALTH INSURANCE ..... 21

    A. EMPLOYEES HIRED BEFORE JULY 1, 2011 ..... 21

B. EMPLOYEES HIRED ON OR AFTER JULY 1, 2011 .....	23
SECTION 19.    PHYSICAL EXAMINATIONS – MANAGEMENT .....	23
SECTION 20.    LEAVES OF ABSENCE.....	23
A. MISCELLANEOUS LEAVES OF ABSENCE .....	23
B. FAMILY CARE AND MEDICAL LEAVES .....	24
SECTION 21.    VACATION ACCRUAL RATE.....	25
SECTION 22.    VACATION LEAVE.....	26
SECTION 23.    SICK LEAVE FOR EXECUTIVE, MANAGEMENT, AND CONFIDENTIAL EMPLOYEES .....	27
SECTION 24.    BEREAVEMENT LEAVE .....	29
SECTION 25.    MANAGEMENT LEAVE .....	30
SECTION 26.    WORKERS’ COMPENSATION .....	30
SECTION 27.    JURY LEAVE.....	31
SECTION 28.    COURT WITNESS LEAVE .....	31
SECTION 29.    MILITARY LEAVE.....	31
SECTION 30.    LEAVE DONATIONS – INJURY/ILLNESS/DISABILITY .....	31
SECTION 31.    LEAVE DEDUCTIONS .....	32
SECTION 32.    HOLIDAYS .....	32
SECTION 33.    SEVERANCE PAY .....	34
SECTION 34.    WORKDAY SCHEDULES .....	35
SECTION 35.    Y-RATING – MANAGEMENT EMPLOYEES.....	35
SECTION 36.    SICK LEAVE FOR PART TIME UNREPRESENTED EMPLOYEES, INCLUDING LAW ENFORCEMENT RECRUITS AND FIREFIGHTER RECRUITS .....	35
SECTION 37.    FRINGE BENEFITS – ELIGIBILITY.....	37
SECTION 38.    AMENDMENTS .....	38

## **SECTION 1.           PURPOSE**

The Fringe Benefits Resolution is a consolidation of previously adopted resolutions concerning City Council, Executive Management, Management, and Unrepresented Employees. Resolution No. 7598 sets forth the wages, hours, and other terms and conditions of employment for employees within these classifications.

## **SECTION 2.           DEFINITIONS**

As used herein and in the general salary resolution, the following terms shall have the following meanings:

“Classification” shall mean a group of positions having sufficiently similar duties, responsibilities, and qualifications to be designated by the same descriptive title, and as to which the same salary range may be made to apply with equity.

“Employee” shall mean a full-time budgeted employee of the City of Arcadia.

“Employment Date” shall mean the period of continuous full-time employment from and after such employment date shall be used in computing longevity pay, sick leave, and vacation and shall be the starting point for determining salary step increases.

“Executive Management Employee” shall mean an unrepresented management Employee who is the head of a City Department. Employees who are in the Classification of Development Services Director, Public Works Services Director, Administrative Services Director, Recreation and Community Services Director, Library and Museum Services Director, Assistant City Manager, Human Resources Director, and similar Classifications as they may be added or amended over time shall be considered Executive Management Employees in the Miscellaneous category. Employees who are in the Classification of Police Chief, Fire Chief, and similar Classifications as they may be added or amended over time shall be considered Executive Management Employees in the Safety category. Also known as “Department Director”.

“Management Employees” shall mean those full-time Employees having responsibility for formulating, administering, or managing the implementation of City policies who are unrepresented and who are not Executive Management Employees. Typical Employees in the Classification of Management Aide, Buyer, Purchasing Officer, Recreation Supervisor, Human Resources Analyst, Crime Analyst, Management Analyst, Police Records Manager, Senior Human Resources Analyst, Senior Management Analyst, Transportation Services Manager, City Clerk, Project Manager, Deputy Director of Recreation and Community Services, Planning Services Manager, Accounting Supervisor, Accountant, Senior Accountant, Environmental Services Manager, Information Technology Manager, Communication and Engagement Officer, General Services

Superintendent, Streets Superintendent, Library Services Manager, Utilities Manager, Principal Civil Engineer, Building Official, Fire Marshal, Economic Development Manager, Human Resources Manager, Deputy City Manager, Deputy Development Services Director, City Engineer, Deputy Public Works Services Director and similar Classifications as they may be added or amended over time shall be considered Management Employees in the Miscellaneous category. Typical Employees in the Classification of Police Lieutenant, Fire Battalion Chief, Deputy Fire Chief, Police Captain, and similar Classifications as they may be added or amended over time shall be considered Management Employees in the Safety category.

“Miscellaneous Employees” shall mean those employees who are not involved in law enforcement, fire suppression, the protection of public safety, or employed in a position designated by law as local safety.

“Part-Time Unrepresented Employees” shall mean a part-time employee who is at-will and not deemed an Executive Management, Management, Unrepresented Confidential, or Unrepresented Employee. Typical Employees in the Classification of Library Aide I/II, Activity Leader I/II, Laborer, Police Cadet, Administrative Intern, Camp Manager, Fire Prevention Aide, Recreation Specialist, Volunteer Services Coordinator, Reserve Police Officer I/II and similar classifications as they may be added or amended over time shall be considered part-time unrepresented. This excludes the positions of Law Enforcement Recruit and Firefighter Recruit.

“Recognized Employee Organization” means an Employee organization which has been formally acknowledged by the City as the Employee organization that represents Employees in designated classifications in an appropriate representation unit.

“Safety Employees” shall mean those employees who are involved in law enforcement, fire suppression, the protection of public safety, or who are employed in a position designated by law as local safety.

“Salary Advancement” shall mean an increase in salary from current step to a higher step within the same salary range based upon performance and continuous service in the same class.

“Unrepresented Confidential Employee” shall mean any benefitted Employee (receiving CalPERS and a benefit allowance) that is not an Executive or Management Employee, is not represented by a recognized Employee organization, and typically handles confidential matters as a course of their job duties. Classifications in this group include Executive Assistant assigned to the City Manager’s Office, Human Resources Technician, and similar Classifications as they may be added or amended over time (referred to as Confidential herein).

“Unrepresented Employee” shall mean any Employee that is not an Executive or Management Employee and is not represented by a recognized Employee organization. This includes the positions of Law Enforcement Recruit and Firefighter Recruit.

**SECTION 3.           COMPENSATION**

**A.    BASE SALARIES AND ONE-TIME BONUS**

The base salaries of Safety and Miscellaneous Executive Management, Safety and Miscellaneous Management, and Unrepresented Confidential Employees covered by this resolution will be increased as follows: Retroactive increases will be given only to those employees on City payroll as of the date of adoption of this resolution.

- Effective the beginning of the pay period containing July 1, 2024: 7%
- Effective the beginning of the pay period containing July 1, 2025: 6%
- Effective the beginning of the pay period containing July 1, 2026: 5%

In addition, it is the intent to adjust salary ranges to allow at least a 10% increase when promoting into higher Classifications. The base salary increases for all Classifications covered by this resolution, including any applicable adjustments, have been incorporated into the salary schedules as set forth in Exhibit A and incorporated herein.

Employees covered by this resolution will receive a one-time Non-PERSable bonus paid through City payroll upon the adoption of this resolution. The collective amount of \$114,300 will be distributed evenly to Employees covered by this resolution as of date of adoption.

**B.    BILINGUAL PAY**

The City will offer bilingual pay to Management and Confidential Employees. The total number of positions authorized for bilingual pay at any time is at the discretion of the Employee’s Department Director. To qualify, an Employee must pass the test developed or utilized by the City for languages specified by the City. An employee designated to receive bilingual pay shall receive \$75 per pay period for Mandarin and \$40 per pay period for all other languages.

**SECTION 4.           SALARY STEP ADVANCEMENT**

A.    The advancement through the salary steps shall be based upon performance and continuous service in the same classification. The percentage between steps is approximately 2.5%. Employees will advance in their rates of compensation two

steps (approximately 5.0%) on their anniversary dates. The following schedule is an example of merit increases when an Employee begins employment at step A in a new classification not previously held by the Employee:

A Step to C Step: 6 months

All other Steps: 12 months

Employees starting service at Step A in a new classification, whether newly hired or promoted, will be eligible for a step increase consideration at 6 months of service in their new classification. If a step increase is granted at 6 months, the next step increase consideration will be 12 months from this date and annually thereafter. Employees starting service at any other salary step in a new classification, whether newly hired or promoted, will be eligible for a step increase consideration at 12 months of service in their new classification and annually thereafter.

For Department Directors reporting directly to the City Manager, the advancement through the salary steps shall be based on performance without regard to the continuous service time requirements cited above. The rate of advancement shall be from 0% to 7.5%, or no movement to a maximum of three steps. Pursuant to the City Charter Section 809, evaluation of the Library and Museum Services Director shall be by the Library Board; however, the City Manager shall provide input into the process.

- B. Salary step advancements may be withheld or delayed by the appointing authority if an Employee's performance does not merit such advancement.
- C. With the approval of the City Manager, an Employee may be hired at any step within the salary range applicable to the position.
- D. The City Manager shall have the authority to advance an Employee's salary step within that Employee's salary range when the purpose is to correct an existing inequity or give recognition to exceptional performance.
- E. Upon adoption of this Resolution and until June 30, 2027, unless extended by the City Council, the City Manager shall have discretionary authority to allow an annual performance bonus up to 3% of an Employee's annual salary to full-time Employees covered by this resolution who receive a Meritorious or Superior evaluation. Receiving a Meritorious or Superior evaluation is not a guarantee of receiving a bonus, only a minimum standard for qualification. It shall be the City Manager's sole authority to determine whether to allow a bonus and at what amount. The performance bonus shall be subject to the availability of funds as determined by the City.

**SECTION 5. PROMOTIONAL STEP ADVANCEMENT**

- A. When an Employee is promoted, their pay shall advance to the lowest salary step in the new classification range such that it will provide a 5% increase in compensation, or two steps. If the lowest salary in the new classification is the top step, the Employee's pay will be advanced to the top step, even if it provides less than a 5%, or two step, increase.
- B. When an Employee is promoted to a higher classification, the date of the promotion shall be used in determining the date of the future step increases. Future step increases for promotions will follow Section 4. "Salary Step Advancement".

**SECTION 6. OVERTIME**

- A. When necessary to perform essential work, a Department Director may require Management and Unrepresented Employees to work at any time other than during regular working hours until such work is accomplished. Management and Executive Management Employees are generally considered positions that are exempt from standard overtime rules. Job specifications for each Classification shall clearly state whether the position is considered exempt. Employees that are not exempt from standard overtime rules and are required to work hours which cause the Employee to be in a work status in excess of 40 hours in a designated workweek shall be paid at the rate of time and one-half the Employee's regular rate of pay. The Department Director may permit an Employee to accumulate compensatory time in lieu of paid overtime; however, the Employee shall not be permitted to accumulate more than 100 hours of compensatory time at any time.
- B. Fire Battalion Chiefs working in excess of a 56-hour workweek shall receive overtime at straight time for operational assignments as defined by the Fire Chief and are eligible for Management Leave. A Fire Battalion Chief assigned to a strike team and working in excess of a 56-hour workweek will receive overtime at 1.5 times the hourly rate. No other Management Employees are eligible to receive any form of overtime compensation for additional hours worked, except as stated in Section 8.
- C. A Deputy Fire Chief who works in excess of a 40-hour workweek for purposes of strike team backfill or while deployed on a strike team assignment will receive overtime at 1.5 times the hourly rate when authorized by the Fire Chief.

**SECTION 7. RETIREMENT**

**A. EMPLOYEES HIRED BEFORE JULY 1, 2011**

The City contracts with the State of California Public Employees Retirement System (CalPERS) for the classifications contained in this Resolution. The plan shall include the following options:

1. Miscellaneous Employees - 2.5% @ 55 retirement formula (Government Code §21354.4); Public Safety Employees - 3% @ 50 retirement formula (Government Code §21362.2).
2. Single highest year final compensation (Government Code §20042).
3. Post Retirement Survivor Continuance.
4. Credit for Unused Sick Leave (Government Code §20965).
5. 1959 Survivors Benefit for which each Employee contributes \$0.93 per pay period.
6. Third level 1959 Survivors Benefit allowance (Government Code §21573).
7. Military service credit as public service option (Government Code §21024). The Employee is responsible for paying for this benefit.
8. As permitted by CalPERS, Employees may elect to purchase service credit by remitting payment to CalPERS via payroll deductions. If the Employee elects this option, the City will allow Employees to elect those payments as pre-tax payroll deductions for service purchases.
9. Special compensation items shall be reported to CalPERS in accordance with applicable law.
10. Employees shall make contributions to offset a portion of the City's costs related to CalPERS retirement benefits. The Employee cost-sharing will be accomplished through pre-tax deductions in the manner contemplated by Government Code §20516(f). It is recognized that the IRS has yet to take a position on the pre-tax status of deductions made under §20516(f) and in the event that, subsequent to the effective date of this provision, the IRS determines that such deductions do not qualify for pre-tax status, Employees will be notified and the provisions set forth herein will be reviewed by the City Manager and City Council. The cost sharing arrangement will be implemented as follows:
  - a. Miscellaneous Employees: Employees will pay 7% of PERSable compensation to CalPERS retirement via payroll deduction toward the City's Employer Contribution to CalPERS and said amount will be allocated to the employer's account.
  - b. Public Safety Employees: Employees will continue to pay 9% of PERSable compensation for CalPERS retirement via payroll deduction toward the City's Employer Contribution to CalPERS and said amount will be allocated to the employer's account. Employees will also continue

to contribute an additional 3% cost for CalPERS retirement, for a total of 12%.

11. In addition to the foregoing cost sharing payments, Miscellaneous Employees shall continue to pay 1% of the member contribution to CalPERS.
12. The City shall continue to pay the cost of the Employees' member contribution (EPMC) to CalPERS in the amount of 7% for Miscellaneous Employees and 9% for Public Safety Employees and shall continue to report that as additional compensation pursuant to §20636(c)(4) of the Government Code. Further, said amount will be allocated to the Employee's retirement account.
13. Pre-Retirement Option 2W Death Benefit (Government Code §21548): Pursuant to §20516(f) (Employee Sharing Cost of Additional Benefits), Employees will split the cost of this benefit with the City through pre-tax deductions in the manner contemplated by §20516(f) of the Government Code. It is recognized that the IRS has yet to take a position on the pre-tax status of deductions made under §20516(f) and in the event that, subsequent to the effective date of this provision, the IRS determines that such deductions do not qualify for pre-tax status, Employees will be notified and this provision shall be reviewed by the City Manager and City Council. Employees shall pay for one-half of the cost of this optional benefit, which was determined to be a total of 0.276% for Miscellaneous and 0.220% for Public Safety Employees. The cost-sharing arrangement will be implemented as follows:
  - a. Miscellaneous Employees: Employees will pay 0.138% of PERSable compensation to CalPERS retirement via payroll deduction; and the City will pay 0.138% of PERSable compensation to CalPERS retirement.
  - b. Public Safety Employees: Employees will pay 0.110% of PERSable compensation to CalPERS retirement via payroll deduction; and the City will pay 0.110% of PERSable compensation to CalPERS retirement.

B. EMPLOYEES HIRED ON OR AFTER OCTOBER 9, 2011, OTHER THAN NEW CALPERS MEMBERS HIRED AFTER JANUARY 1, 2013

The City contracts with the State of California Public Employees Retirement System (CalPERS) for the classifications contained in this Resolution. The plan shall include the following options:

1. Miscellaneous Employees - 2.0% @ 60 retirement formula (Government Code §21363.1); Public Safety Employees - 3% @ 55 retirement formula (Government Code §21363.1).
2. 3-year average final compensation period (Government Code §20037).

3. Post Retirement Survivor Continuance.
4. Credit for Unused Sick Leave (Government Code §20965).
5. 1959 Survivors Benefit for which each Employee contributes \$0.93 per pay period.
6. Third level 1959 Survivors Benefit allowance (Government Code §21573).
7. Military service credit as public service option (Government Code §21024). The Employee is responsible for paying for this benefit.
8. As permitted by CalPERS, Employees may elect to purchase service credit by remitting payment to CalPERS via payroll deductions. If the Employee elects this option, the City will allow Employees to elect those payments as pre-tax payroll deductions for service purchases.
9. Special compensation items shall be reported to CalPERS in accordance with applicable law.
10. Miscellaneous Employees will pay the full 7% member contribution to CalPERS via payroll deduction.
11. Public Safety Employees will continue to pay 9% of PERSable compensation for CalPERS retirement via payroll deduction toward the City's Employer Contribution to CalPERS and said amount will be allocated to the employer's account. Employees will also continue to contribute an additional 3% cost for CalPERS retirement, for a total of 12%.
12. The Pre-Retirement Option 2W Death Benefit (Government Code §21548). Pursuant to §20516(f) (Employee Sharing Cost of Additional Benefits), Employees shall split the cost of this benefit with the City through pre-tax deductions in the manner contemplated by §20516(f) of the Government Code. It is recognized that the IRS has yet to take a position on the pre-tax status of deductions made under §20516(f) and in the event that, subsequent to the effective date of this provision, the IRS determines that such deductions do not qualify for pre-tax status, the Employees will be notified and this provision shall be reviewed by the City Manager and City Council. Employees shall pay for one-half of the cost of this optional benefit which was determined to be a total of 0.276% for Miscellaneous and 0.220% for Public Safety. The cost-sharing arrangement will be implemented as follows:
  - a. Miscellaneous Employees: Employees will pay 0.138% of PERSable compensation to CalPERS retirement via payroll deduction; and the City will pay 0.138% of PERSable compensation to CalPERS retirement.

- b. Public Safety Employees: Employees will pay 0.110% of PERSable compensation to CalPERS retirement via payroll deduction; and the City will pay 0.110% of PERSable compensation to CalPERS retirement.

C. NEW CALPERS MEMBERS HIRED ON OR AFTER JANUARY 1, 2013

The City contracts with the State of California Public Employees Retirement System (CalPERS) for the classifications contained in this Resolution. The plan shall include the following options:

1. Miscellaneous Employees - 2.0% @ 62 retirement formula (Government Code §7522.20); Public Safety Employees – 2.7% at age 57 retirement formula (Government Code §7522.25(d)).
2. 3-year average final compensation period (Government Code §20037).
3. Post Retirement Survivor Continuance.
4. Credit for Unused Sick Leave (Government Code §20965).
5. 1959 Survivors Benefit for which each Employee contributes \$0.93 per pay period.
6. Third level 1959 Survivors Benefit allowance (Government Code §21573).
7. Military service credit as public service option (Government Code §21024). The Employee is responsible for paying for this benefit.
8. As permitted by CalPERS, Employees may elect to purchase service credit by remitting payment to CalPERS via payroll deductions. If the Employee elects this option, the City will allow Employees to elect those payments as pre-tax payroll deductions for service purchases.
9. Special compensation items shall be reported to CalPERS in accordance with applicable law.
10. Miscellaneous Employees will pay 50% of the normal cost, as determined by CalPERS, for member contributions to CalPERS on a pre-tax basis via payroll deduction (Government Code §7522.30).
11. Public Safety Employees will pay 50% of the normal cost, as determined by CalPERS, for member contributions to CalPERS on a pre-tax basis via payroll deduction (Government Code §7522.30).
12. The Pre-Retirement Option 2W Death Benefit (Government Code §21548). Pursuant to §20516(f) (Employee Sharing Cost of Additional Benefits),

Employees shall split the cost of this benefit with the City through pre-tax deductions in the manner contemplated by §20516(f) of the Government Code. It is recognized that the IRS has yet to take a position on the pre-tax status of deductions made under §20516(f) and in the event that, subsequent to the effective date of this provision, the IRS determines that such deductions do not qualify for pre-tax status, Employees will be notified and this provision shall be reviewed by the City Manager and City Council. Employees shall pay for one-half of the cost of this optional benefit which was determined to be a total of 0.276% for Miscellaneous and 0.220% for Public Safety. The cost-sharing arrangement will be implemented as follows:

- a. Miscellaneous Employees: Employees will pay 0.138% of PERSable compensation to CalPERS retirement via payroll deduction; and the City will pay 0.138% of PERSable compensation to CalPERS retirement.
- b. Public Safety Employees: Employees will pay 0.110% of PERSable compensation to CalPERS retirement via payroll deduction; and the City will pay 0.110% of PERSable compensation to CalPERS retirement.

**D. DEFERRED COMPENSATION**

City Council, Executive, and Management Employees shall have access to the City's established 457 Deferred Compensation Program and the IRC 401(a) defined contribution plan. All administration costs associated with the 401(a) plan shall be paid by the City.

Effective the first pay period following Council adoption of this Resolution, the City will match each Executive and Management employee's contribution to the employee's 457 Deferred Compensation Account up to \$300 per month. It is understood that contributions are made on a per pay period basis, 24 times per year.

**SECTION 8. SPECIAL ASSIGNMENT PAY**

Employees in the classifications of Police Captain and Police Lieutenant assigned to outside reimbursable special details (as approved by the City Manager), including but not limited to race-track traffic control duties, shall be compensated at 6 hours of straight time at the rate of a top step Police Sergeant with an Advanced Post Certificate and Special Assignment Pay (currently 5%).

**SECTION 9. LONGEVITY PAY**

Effective the beginning of the pay period containing July 1, 2024, a Longevity Pay benefit will be provided to Executive, Management, and Confidential Employees based on the following formula:

<b>Completed Years of Continuous Service</b>	<b>Amount Per Pay Period (Executive and Management)</b>	<b>Amount Per Pay Period (Confidential Employees)</b>
5-9 Years:	\$50.00	\$50.00
10-14 Years:	\$138.46	\$76.00
15-19 Years:	\$276.92	\$100.00
20+ Years:	\$369.23	\$230.77

The Longevity Pay benefit is effective the pay period an Employee reaches 5, 10, 15 or 20 years of continuous employment with the City.

**SECTION 10. ACTING PAY**

A Management or Confidential Employee who is required, in writing, to work more than 5 working days in a higher classification, which is vacant due to sick leave, family medical leave, injury leave, vacation leave, termination, retirement, or for any other reason as approved by the City Manager, shall receive the following acting pay retroactive to the first day of the assignment:

1. 5% above their current rate of pay or A step of the higher classification, whichever is higher; or any step within the classification as approved by the City Manager; or
2. Should such percentage exceed the top step of the range for the higher classification, the Employee shall receive compensation at the top step of the higher classification.
3. Nothing contained herein shall apply to an Employee who is being trained by the City to qualify for a higher classification or who temporarily assumes some of the duties of a higher position.

If an acting assignment exceeds or is expected to exceed 30 calendar days, the acting Employee will receive the fringe benefits of said position for the duration of the assignment as applicable and as determined by the City Manager.

**SECTION 11. TUITION ADVANCEMENT/REIMBURSEMENT**

Employees shall be eligible for tuition advancement or reimbursement who have completed at least one probationary period in the Classified Service, or one year of continuous service if employment is “at-will,” subject to the conditions below.

To qualify for tuition advancement/reimbursement, a Tuition Advancement/Reimbursement Form must be submitted and pre-approved by the Employee’s Department Director and Human Resources Director, before the course(s) begin.

Tuition advancement or reimbursement shall only be for the first degree in each education level that an employee seeks to obtain, and shall only be for "job-related" courses, specialized training, or degree programs that are directly related to the Employee's position as determined by the City Manager or designee. The City Manager or their designee may grant approval for tuition advancement or reimbursement if they determine that a second degree in any education level is both beneficial and job-related.

The Tuition Advancement/Reimbursement Program will operate on a fiscal year basis (July 1 through June 30) and shall be subject to the availability of funds as determined by the City. The maximum advancement or reimbursement amount shall be \$4,126 for undergraduate courses and \$5,062 for graduate courses per fiscal year. Eligible fees include tuition, on campus parking fees, and textbooks. All other fees are subject to approval by the City Manager. School supplies are not reimbursable.

All course work must be completed while employed by the City of Arcadia with a passing grade of "C" or equivalent when numerical score or pass/fail grade is given. If the Employee either does not receive a "C" or better or for any reason does not finish the class, the advance is due and payable.

Any Employee who voluntarily retires or terminates employment or is terminated for disciplinary cause within one year from the completion of a class or classes shall refund all tuition paid under this provision for those specific classes unless they were required to attend by the appointing power. An Employee who separates employment and who received tuition advancement and did not complete a class or classes within 1 year from the advancement, shall refund all tuition advanced and be subject to the provisions outlined in the Advanced Tuition Participation and Advancement Agreement. Employees who retire on a Disability or Industrial Disability Retirement or are laid off shall not be required to refund tuition fees under this provision.

The City reserves the right to investigate any school and approve or disapprove it for advancement or reimbursement if such action appears warranted. Courses must be taken at an accredited education institution, which is defined as any college or university which has been accredited by a recognized government or professional accrediting body (as determined by the City). Additionally, the City reserves the right to deny any course(s), specialized training, or degree programs determined by the City Manager to be non-job related.

## **SECTION 12. UNIFORMS**

- A. Effective July 1, 2024, and at the beginning of each fiscal year, Employees in the classification of Police Chief, Police Captain, and Police Lieutenant shall receive \$1,000 for the purchase of safety equipment. \$647 shall be reported to CalPERS as special compensation for Uniform Allowance. This amount shall be prorated if hired or promoted after the start of the fiscal year.

- B. At the beginning of the fiscal year, employees in the classification of Fire Chief, Deputy Fire Chief, and Battalion Chief shall have a uniform allowance of \$655 reported annually to CalPERS as special compensation. This amount shall be prorated if hired or promoted after the start of the fiscal year.
- C. For the duration of the Resolution, uniforms shall be provided to those employee Management Employees currently receiving uniforms under the same conditions specified in their respective Department Policies. The City shall continue to report an amount up to \$170.56 per year to CalPERS as special compensation for Uniform Allowance to the extent permitted by law.

“New Members” as defined under the Public Employees’ Pension Reform Act of 2013 will not have the value of the uniforms reported as special compensation.

**SECTION 13. AUTO ALLOWANCE**

Subject to the City Manager’s sole discretion, Executive Management Employees may receive either a City provided vehicle or an auto allowance of up to \$350 per month, depending on duties and requirements of the position. Any benefits provided under this section are considered taxable per IRS Code. See IRS Publication 463, Travel, Entertainment, Gift, and Car Expenses for more information concerning taxation of this benefit.

**SECTION 14. MILEAGE REIMBURSEMENT**

Mileage is reimbursed for travel in connection with City business and shall be paid in accordance with the prevailing IRS rate. Prior approval must be obtained from the immediate supervisor or Department Director. If travel is required frequently during a month, reimbursement shall be made once per month. Completed mileage forms shall be submitted to the Department Director consistent with the applicable administrative policy. Except as expressly authorized by the City Manager, Employees receiving an Auto Allowance described in Section 13 will not qualify for mileage reimbursements described herein.

**SECTION 15. BENEFIT ALLOWANCE FOR HEALTH, DENTAL, AND VISION**

**A. CONTRIBUTION FOR EMPLOYEES HIRED BEFORE OCTOBER 1, 2024**

The City provides City Council, Executive, Management and Confidential Employees, as well as Law Enforcement Recruits and Firefighter Recruits the Section 125 Cafeteria Plan contributions as follows:

1. CalPERS Health Program: The City will contribute the minimum employer contribution required pursuant to Government Code §22892(b) of the Public Employees’ Medical and Hospital Care Act (“**PEMHCA Minimum**”) per month

per Employee for health insurance. The PEMHCA minimum is included within the City's contribution.

2. Dental Insurance: Mandatory enrollment: The City will contribute the Employee only cost for Delta Care USA insurance per month ("Dental Contribution") toward one of two dental plans. Additional coverage may be purchased through the Optional Benefits allocation. The Dental Contribution is included in the monthly benefit allowance.
3. Vision Insurance: The City shall provide each Employee with a vision plan, with the City paying the premium. The vision plan will be Vision Service Plan, Option B. The City will pay the premium up to the cost of the family plan.
4. Optional Benefits: For employees hired before October 1, 2024, subject to the PEMHCA minimum and mandatory dental insurance enrollment premium as specified in above paragraphs 1 and 2, the City shall contribute the remaining amount of Employee's benefit allowance through a contribution to an Internal Revenue Code §125 Cafeteria Plan as follows, effective July 1, 2024:

Health/Dental/Vision Benefit Allowance (per month)

	Employee Only	Employee +1	Family
City Council & Miscellaneous Executive Management	\$1,504.00	\$1,550.00	\$2,150.00
Public Safety Executive Management	\$1,548.50	\$1,550.00	\$2,150.00
Public Safety Management	\$1,445.50	\$1,550.00	\$2,150.00
Miscellaneous Management	\$1,402.00	\$1,550.00	\$2,150.00
Unrepresented Confidential Employees	\$1,072.00	\$1,400.00	\$1,800.00
Law Enforcement Recruits & Firefighter Recruits	\$ 620.00	\$700.00	\$900.00

- a. If the premium cost of the health plan exceeds the City contribution, the Employee shall pay through payroll deduction the difference between the monthly premium and the amount contributed by the City.
- b. The Employee's exercise of the option to use the difference toward dependent health coverage or the deferred compensation plan is subject to the conditions controlling enrollment periods and eligibility established by the respective plans or carriers.

- c. Dependent enrollment will require proof of eligibility for dependent status including social security number, marriage, birth, and/or adoption certificates.

**B. CONTRIBUTION FOR EMPLOYEES HIRED ON OR AFTER OCTOBER 1, 2024**

The City provides City Council, Executive, Management and Confidential Employees, as well as Law Enforcement Recruits and Firefighter Recruits the Section 125 Cafeteria Plan contributions as follows:

1. CalPERS Health Program: The City will contribute the minimum employer contribution required pursuant to Government Code §22892(b) of the Public Employees’ Medical and Hospital Care Act (“**PEMHCA Minimum**”) per month per Employee for health insurance. The PEMHCA minimum is included within the City’s contribution.
2. Dental Insurance: Mandatory enrollment: The City will contribute the Employee only cost for Delta Care USA insurance per month (“Dental Contribution”) toward one of two dental plans. Additional coverage may be purchased through the Optional Benefits allocation. The Dental Contribution is included in the monthly benefit allowance.
3. The City shall provide each Employee with a vision plan, with the City paying the premium. The vision plan will be Vision Service Plan, Option B. The City will pay the premium up to the cost of the family plan.
4. Optional Benefits: For employees hired on or after October 1, 2024, subject to the PEMHCA minimum and mandatory dental insurance enrollment premium as specified in above paragraphs 1 and 2, the City shall contribute the remaining amount of Employee’s benefit allowance through a contribution to an Internal Revenue Code §125 Cafeteria Plan as follows, effective October 1, 2024:

Health/Dental/Vision Benefit Allowance (per month)

	Employee Only	Employee +1	Family
City Council, Miscellaneous & Safety Executives, Miscellaneous and Safety Management	\$ 866	\$ 1,550	\$2,150
Unrepresented Confidential Employees	\$866	\$1,400	\$1,800
Law Enforcement Recruits & Firefighter Recruits	\$ 620	\$ 700	\$ 900

- a. If the premium cost of the health plan exceeds the City contribution, the Employee shall pay through payroll deduction the difference between the monthly premium and the amount contributed by the City.
- b. Dependent enrollment will require proof of eligibility for dependent status including social security number, marriage, birth, and adoption certificates.

**C. CASH IN LIEU OF COVERAGE OR CASH FOR EXCESS CONTRIBUTIONS**

- 1. **Excess Contributions for Employees Hired Before July 1, 2021.** If the City's contribution, up the maximum amount shown below, exceeds the cost of the employee's elected coverage (e.g. Employee Only, Employee +1, Family), the difference shall be contributed as taxable income.

City Council & Miscellaneous Executive Management	\$1,504.00
Public Safety Executive Management	\$1,548.50
Public Safety Management	\$1,445.50
Miscellaneous Management	\$1,402.00
Unrepresented Confidential Employees	\$1,072.00
Law Enforcement Recruits	\$ 620.00

- a. Those employees hired before July 1, 2021, who receive cash as taxable income will have the amount capped to the amount they were receiving as of July 1, 2021, and then reduced to an amount that will allow the City-wide Total Medical Plan Payment to be less than 20%. The amount of the reduction will not be greater than 19.51% of the amount received as of July 1, 2021. This amount will result in the employee's new capped cash-in-lieu.
- b. Those employees hired before July 1, 2021, who qualify to receive cash as taxable income and who subsequently reduce their cash-in-lieu amount through a qualifying change, shall be subject to the new cash-in-lieu cap based on their elected reduced amount, and will forfeit their previous cash-in-lieu cap.
- c. Employees hired before July 1, 2021, who did not take cash-in-lieu as of July 1, 2021, for any unused portion of the City's contribution toward benefits shall no longer be eligible for cash-in-lieu.

2. **Cash In Lieu of City Coverage for Employees Hired Before July 1, 2021.** Employees are required to carry one of the City's designated medical plans unless they opt out. Employees hired before July 1, 2021 may receive cash-in-lieu for opting out of the City's designated medical plans, up to the maximum amounts listed in Section 15.C.1. above, during the annual open enrollment period by signing a written waiver each year, that attests that the employee and each member of the employee's Tax Family (i.e. all individuals for whom the employee expects to claim a personal exemption deduction for the upcoming tax year) each has alternative minimum essential coverage (other than coverage in the individual market and other than individual coverage through Covered California) for the upcoming tax year. If Employees provide the executed written waiver and documentation confirming that they are enrolled in an alternative group health plan that satisfies the above at open enrollment or within 30 days after the start of the plan year, they will be entitled to the maximum allotted cash referenced in Section 15.C.1. above, and subject to the limitations enumerated in Section 15.C.1.a-c to be taken as taxable income.

## **SECTION 16. LIFE INSURANCE**

- A. Effective as soon as practical with the insurance carrier, the City shall provide the City Council with Group Term Life and Accidental Death and Dismemberment (AD&D) insurance in the amount of \$75,000.
- B. Effective as soon as practical with the insurance carrier, Executive and Management Employees shall be provided Group Term Life and AD&D insurance equal to their annual salary rounded to the nearest (next highest) one thousand dollars, plus an additional \$75,000 Term Life and AD&D policy.
- C. Effective as soon as practical with the insurance carrier, the City shall provide Confidential and Unrepresented Employees with Group Term Life and AD&D insurance in the amount of \$75,000.
- D. An optional Employee-paid Group Term Life insurance policy shall be offered to all full-time Executive, Management, Confidential, and Unrepresented Employees.

## **SECTION 17. LONG TERM DISABILITY INSURANCE**

- A. The City shall provide Executive, Management, and Confidential Employees with Group Long Term Disability (LTD) Insurance.
- B. An optional Employee-paid Group LTD "buy-up benefit" shall also be offered to Executive, Management, and Confidential Employees.
- C. Executive and Management Employees will receive 0.5% of their annual salary that may be used to buy additional LTD insurance from the City's provider to

achieve up to \$10,000 per month maximum benefits coverage. If the Employee does not desire additional LTD insurance or there is a portion of the 0.5% remaining, the Employee may take this amount as additional compensation.

**SECTION 18. RETIREE HEALTH INSURANCE**

**A. EMPLOYEES HIRED BEFORE JULY 1, 2011**

**Program Description for Employees Retiring On or After January 1, 2012**

For Employees hired before July 1, 2011, and retiring from the City on or after January 1, 2012, the City will provide a Premium Payment for the purpose of purchasing health coverage offered through CalPERS for the Tier II Retiree and their spouse in an amount not to exceed the monthly premium applicable to the coverage level for the retiree (i.e., One-Party or Two-Party) as shown in the chart below.

	Non-Public Safety Classifications	Public Safety Executive and Management
One-Party (Retiree Only)	\$ 505.63*	\$ 605.63*
Two-Party (Retiree + Spouse)	\$ 1,011.26*	\$ 1,111.26*

*\* These amounts include the PEMHCA Minimum. The PEMHCA Minimum is paid directly to CalPERS, not to the eligible retiree.*

**Program Description for Employees Retiring On or After January 1, 2025**

For Employees hired before July 1, 2011, and retiring from the City on or after January 1, 2025, the City will provide a Premium Payment for the purpose of purchasing health coverage offered through CalPERS for the Retiree and their spouse in an amount not to exceed the monthly premium applicable to the coverage level for the retiree (i.e., One-Party or Two-Party) as shown below. The amounts shown below include the PEMHCA Minimum. The PEMHCA Minimum is paid directly to CalPERS, not to the eligible retiree.

- One-Party (Retiree Only): \$866
- Two-Party (Retiree + Spouse): \$1,550

**Premium Payment**

The total applicable Premium Payment shall be payable in the following form: (1) Public Employees' Medical and Hospital Care Act ("PEMHCA") Minimum contribution payable directly to CalPERS, and (2) a reimbursement to the Retiree equal to the difference between the cost of the plan in which the Retiree enrolls, subject to the caps above based on retirement date, and the PEMHCA Minimum contribution ("**Reimbursement**"). If a retiree enrolls in a more expensive plan, they will be responsible for payment of any premium in excess of the capped amount.

As specified below, the Reimbursement shall cease for the Retiree upon eligibility for Medicare coverage, and the Reimbursement shall cease for the spouse upon eligibility for Medicare coverage, or after 15 years, whichever occurs first.

**Eligibility Requirements**

Retirees must be “eligible retirees” in order to receive the benefits described in this subsection. Eligible retirees must meet the following requirements:

1. **Executive Management Employees** who retire from the City on a service, disability, or industrial disability retirement must have a minimum of 15 years of public service, of which at least 5 continuous years of service are with the City of Arcadia.
  
2. **Management and Confidential Employees** who retire on a service, disability, or industrial disability retirement must have a minimum of 1,000 hours of accumulated sick leave at the date of retirement, except for 56-Hour Fire Safety Management Employees, who shall have a minimum of 1,500 hours.

A Management or Confidential Employee who has fewer than the required accumulated sick leave at the date of retirement may become eligible for the retiree health benefit by paying the City an amount equal to the Employee’s daily pay rate at the time of retirement times the number of hours needed to meet the 1,000 or 1,500 hours of accumulated sick leave requirement with the following restrictions:

- a. The Employee must have reached age 55 (50 for Fire Safety Management). This requirement is not applicable if the Employee is retiring due to disability or industrial disability retirement; and
  
  - b. The Employee must have worked full-time continuously for the City of Arcadia for a minimum of 15 years; and
  
  - c. The Employee would be limited to purchasing a maximum of 350 hours of sick leave (525 hours for 56-Hour Fire Safety Management) provided, however, upon verification of information from a qualified medical provider that an Employee has substantially depleted the Employee’s sick leave accrual due to an absence or absences caused by a serious illness or injury suffered by the Employee or a family dependent living in the Employee’s household, this purchase limitation of 350 hours will be excused.
3. **All retirees**, and if applicable, the retiree’s spouse, must be enrolled in CalPERS retiree medical and maintain eligibility to continue in the CalPERS

Health Program as stipulated by CalPERS in order to receive the City's Premium Payment. However, in the event a retiree or spouse is eligible for CalPERS retiree medical, but is unable to secure such coverage because there are no CalPERS plans available in their place of residence, the retiree may receive the City's Reimbursement, provided the retiree submits sufficient proof to the City that they have obtained alternative coverage and have made the necessary premium payments. The retiree shall also notify the City immediately if such alternative coverage is cancelled or otherwise ceases. The retiree shall solely be responsible for obtaining and maintaining such alternative coverage.

4. **Termination of Eligibility:** An eligible retiree shall cease to be eligible for the City's Reimbursement upon becoming eligible for Medicare coverage. The retiree's spouse shall become ineligible for the City's Reimbursement upon becoming eligible for Medicare coverage or after 15 years, whichever occurs first. Accordingly, the City's Reimbursement will cease upon becoming ineligible.

B. EMPLOYEES HIRED ON OR AFTER JULY 1, 2011

For Employees hired on or after July 1, 2011, that retire from the City and who remain enrolled in a CalPERS health plan after retirement, the City will pay no more than the PEMHCA Minimum contribution, payable directly to CalPERS, and shall not be reimbursed or otherwise receive payment from the City for health insurance premiums in excess of the PEMHCA Minimum contribution.

**SECTION 19. PHYSICAL EXAMINATIONS – MANAGEMENT**

Miscellaneous Executive and Management Employees have the option to receive a biannual comprehensive physical medical examination at no cost to the Employee. Public Safety Executive Management and Management Employees have the option to receive the physical annually, at no cost to the Employee. The City shall establish the terms and conditions of the physical examination.

**SECTION 20. LEAVES OF ABSENCE**

A. Miscellaneous Leaves of Absence

Upon the written request of an Employee stating the reasons therefore, the appointing power with the approval of the City Manager shall have power to grant leaves of absence with or without pay, subject to the following restrictions:

1. Length. Leave of absence with or without pay may be granted for a period not to exceed 1 year with the exception that military leaves may be granted for the duration of a war or national emergency or as required by the Military and Veteran's Code.

2. Reason. A leave of absence may be granted, provided the Employee meets all other requirements set forth in this rule, who desires to attend school or college or to enter training to improve the quality of their service, who enters military service of the United States, who is temporarily incapacitated by illness, or who presents some other reasons equally satisfactory.
3. Right to Return. The granting of a leave of absence without pay confers upon the Employee the right to return to their classification before or at the expiration of their leave of absence. Therefore, a leave of absence shall be granted only to an Employee who intends to return to their classification with the City. An Employee who fails to report for work at the end of an approved leave will be deemed to have voluntarily resigned.
4. Service Record. A request for leave of absence will not be considered unless the Employee presenting the request has a satisfactory service record.
5. An Employee granted a leave of absence may be required by the appointing power or the City Manager to obtain and present a fitness for duty certification from a health care provider that the Employee is able to resume work. Failure to provide such certification will result in denial of restoration.
6. The granting of a leave of absence of 30 days or less, with or without pay, shall not constitute an interruption of service within the meaning of this subsection. The granting of a leave of absence with or without pay of more than 30 days shall constitute an interruption of service unless, in the action granting such leave of absence, it is provided that such leave of absence shall not constitute an interruption of service.
7. The City shall continue to provide health, dental, life, and disability insurance for an Employee granted a leave of absence for up to 30 calendar days. It shall be the responsibility of the Employee who wishes to continue any insurance coverage beyond the 30 calendar days to notify Human Resources of their intent to continue coverage and remit the full monthly premium for any coverage to the Administrative Services Department. However, if an Employee has accrued leaves and uses a minimum of 40 hours of leave per pay period, the City will continue normal health insurance contributions. The aforementioned leaves must be permissible with the specific use requirements of such leave.

B. Family Care and Medical Leaves

Upon the written request of an Employee, the City shall grant any and all Family Care and Medical Leaves as required by law.

**SECTION 21. VACATION ACCRUAL RATE**

- A. Miscellaneous and Safety Executive Management Employees, with the exception of temporary appointments, shall accumulate vacation for continuous years of fulltime service with the City of Arcadia, beginning with the first full pay period of employment, as shown below.

<b>Continuous Years of Service</b>	<b>Hours Per Pay Period</b>
Through completion of the 4 <sup>th</sup> year:	4.616
Beginning of the 5 <sup>th</sup> year through completion of the 9 <sup>th</sup> year:	5.231
Beginning of the 10 <sup>th</sup> year through completion of the 14 <sup>th</sup> year:	6.770
Beginning of the 15 <sup>th</sup> year and beyond:	7.692

Additionally, Miscellaneous and Safety Executive Management Employees shall accumulate vacation at the rate of 7.692 hours per pay period after they have served 20 years in paid public service with all public agencies including at the City of Arcadia and any other public service organization where they were employed, subject to the written approval of the City Manager.

- B. Miscellaneous Management and Confidential Employees, with the exception of temporary appointments, shall accumulate vacation for continuous years of fulltime service with the City of Arcadia, beginning with the first full pay period of employment, as shown below.

<b>Continuous Years of Service</b>	<b>Hours Per Pay Period</b>
Through completion of the 4 <sup>th</sup> year:	3.077
Beginning of the 5 <sup>th</sup> year through completion of the 9 <sup>th</sup> year:	4.616
Beginning of the 10 <sup>th</sup> year through completion of the 14 <sup>th</sup> year:	5.231
Beginning of the 15 <sup>th</sup> year and beyond:	6.154

- C. Battalion Chiefs in the Fire Department on a 24-hour shift shall accumulate vacation for continuous years of fulltime service with the City of Arcadia, beginning with the first full pay period of employment, as shown below.

<b>Continuous Years of Service</b>	<b>Hours Per Pay Period</b>
Through completion of the 9 <sup>th</sup> year:	6.924
Beginning of the 10 <sup>th</sup> year through completion of the 14 <sup>th</sup> year:	10.154
Beginning of the 15 <sup>th</sup> year and beyond:	11.076

- D. Law Enforcement Recruits and Firefighter Recruits shall not accrue vacation leave.
- E. The City Manager may approve a higher vacation accrual rate based on total public agency work experience for new hires covered by this resolution.

**SECTION 22. VACATION LEAVE**

- A. **Accrual Cap:** Effective the beginning of the pay period following Council adoption of this Resolution, the Employee’s vacation accrual shall be allowed to accumulate as shown below. Once an Employee has accumulated the maximum amount, no more vacation will be accrued by the Employee until the Employee’s accrual has been reduced below the maximum amount.

Employee Class	Accrual Cap (Maximum)
Executive Management Employees, and the classifications of Police Captain, Police Lieutenant, and Deputy Fire Chief	400 hours
All Other Management Employees and Confidential Employees	0-4 years of service: 240 hours 5-9 years of service: 240 hours 10-14 years of service: 300 hours 15+ years of service: 400 hours

When through work circumstances and needs of the job, an Employee has been unable to utilize vacation time and this has not been a pattern or practice for that Employee, the City Manager for good cause may approve excess accumulated vacation carried forward into the next fiscal/calendar year.

- B. **Sell Back:** Effective for the calendar year 2025 and every year thereafter, by December 31 (beginning in 2024) of each year, employees who wish to sell back vacation time must make an irrevocable election to cash out up to the total vacation hours that will be earned in the following calendar year, as shown below.

Employee Class	Sell Back Hours Per Calendar Year
Miscellaneous and Safety Executive Management Employees	<u>Up to:</u> 1-4 Yrs: 120 5-9 Yrs: 136 10-14 Yrs: 176 15+ Yrs: 200
Miscellaneous Management Employees and Confidential Employees	<u>Up to:</u> 0-4 Yrs: 80 5-9 Yrs: 120 10-14 Yrs: 136

	15+ Yrs: 160
Police Safety Management Employees, Deputy Fire Chief, and Fire Battalion Chief (40-Hour Workweek)	<u>Up to:</u> 0-9 Yrs: 120 10-14 Yrs: 176 15+ Yrs: 200
Fire Battalion Chief (56-hour workweek)	<u>Up to:</u> 0-9 Yrs: 180 10-14 Yrs: 264 15+ Yrs: 288

**SECTION 23. SICK LEAVE FOR EXECUTIVE, MANAGEMENT, AND CONFIDENTIAL EMPLOYEES**

- A. Executive, Management, and Confidential Employees, with the exception of temporary appointments, assigned to a 40-hour workweek, shall accrue sick leave beginning with the first full pay period of employment on the basis of 3.693 hours for each pay period of service completed with the City or 1 hour for every 30 hours worked, whichever is greater. The maximum accrual per year is 96 hours. Management Employees assigned to a 56-hour workweek, with the exception of temporary appointments, shall accrue sick leave beginning with the first full pay period of employment on the basis of 5.54 hours for each pay period of service completed with the City or 1 hour for every 30 hours worked, whichever is greater. The maximum accrual per year is 144 hours.
- B. Paid sick leave will carry over each year of employment. Executive and Management Employees shall be allowed unlimited accumulation of sick leave. Confidential Employees may accumulate up to a maximum of 1,500 hours.
- C. Except as provided hereinafter, sick leave means authorized absence from duty of an employee who is temporarily disabled and unable to work due to one of the following:
1. Diagnosis, care, or treatment of an existing health condition of, or preventative care for, an employee
  2. Diagnosis, care, or treatment of an existing health condition of, or preventative care for, an employee's family member, which includes parent (biological, adoptive, foster parent, step parent, legal guardian, or a person who stood loco parentis when employee was a child), child (biological, adoptive, foster child, step child, legal ward, or a child to whom the employee stands loco parentis regardless of age or dependency status), spouse, registered domestic partner, parent-in-law, sibling, grandchild, or grandparent
  3. For an employee who is a victim of domestic violence, sexual assault, or stalking for the purposes described in Labor Code sections 230(c) and 230.1 (a); and/or,

4. An employee may designate one additional person per 12-month period at the time the employee requests sick leave.

An employee will make a reasonable effort to schedule medical appointments during non-working hours.

- D. If paid sick leave is taken for the diagnosis, care, or treatment of an existing health condition of, or preventive care of an employee or an employee's family member, the City Manager or designee may require an employee to provide medical certification or evidence of the reason for a sick leave absence that occurs after the employee has used the first 40 hours or five (5) days, whichever is greater depending on the employee's regular scheduled workday, of paid sick leave in a year of employment. The City Manager or designee may require a medical examination by a physician after the employee has used the first 40 hours or 5 days, whichever is greater depending on the employee's regular scheduled workday, of paid sick leave in a year of employment if the medical examination is job related and consistent with business necessity.

For leave pertaining to an employee who is a victim of domestic violence, sexual assault, or stalking, the City Manager or designee may request certification for unscheduled absences beginning on the first day of paid sick leave.

- E. Kin Care Leave: In addition to the prescribed purposes of paid sick leave in Section c. an employee may use up to one-half of their annual accrual of sick leave to care for and attend to a family member who is ill. Every effort shall be made to schedule medical appointments for an ill family member during non-working hours. Family members for purposes of Kin Care leave shall include parent (biological, adoptive, foster parent, step parent, or legal guardian), child (biological, adoptive, foster child, step child, legal ward, a child of a registered domestic partner, or a child to whom the employee stands loco parentis regardless of age or dependency), spouse, or registered domestic partner, and an employee may designate one additional person per 12-month period at the time the employee requests sick leave.
- F. In case of absence due to illness, if the paid sick leave is foreseeable, the Employee shall notify their Department Director within reasonable advance notice. If the paid sick leave is unforeseeable, the employee shall provide notice of the need for the leave as soon as possible. The minimum increment of use of paid sick leave shall be 30 minutes.
- G. The appointing power and City Manager may discipline an employee if sick leave is used for an inappropriate purpose.
- H. If an employee separates from employment with the City and is rehired within one year from separation, up to 80 hours or 10 days, whichever is greater depending

on the employee's regular scheduled workday, of accrued and unused sick leave will be reinstated.

- I. Upon separation from the City of Arcadia, an employee who works in their final pay period, shall receive credit for that pay period's sick leave accrual based on the following:

Management Employees assigned to a 40-hour workweek

0 to 29 hours:	No accrual
30 to 59 hours:	1 hour
60 to 80 hours:	3.693 hours

Management Employees assigned to a 56-hour workweek

0 to 24 hours:	No accrual
25 to 55 hours:	2 hours
56 and above:	5.54 hours

**Unused Sick Leave:**

Unused sick leave is not cashed out upon termination, resignation, retirement, or other separation from employment. Unused sick leave may be converted to retirement service credits, as may be permitted under applicable retirement system laws and regulations.

Employees hired before July 1, 2024, who retire with the City of Arcadia may convert any unused sick leave up to the maximum sick leave accumulation specified in Section 23.B. above.

Employees hired on or after July 1, 2024, who retire with the City of Arcadia may convert any unused sick leave up to 1,000 hours into retirement service credits.

- J. Upon appointment, the City Manager may grant Department Directors a bank of sick leave, not to exceed 96 hours. This bank will be pro-rated for newly appointed Department Directors using five years as the maximum employment period and using 20% for each full year of employment. For example, a newly appointed Department Director that has been employed by the City for two years would be eligible for 40% of the 96 hours (rounded up to the next whole number).

**SECTION 24. BEREAVEMENT LEAVE**

**Death In Family.** At the time of death, or where death appears imminent, in the immediate family, an Employee, with the exception of temporary appointments, may be granted a leave of absence with pay, upon approval of the appointing power and the City Manager.

Immediate family is defined as the spouse, the Employee or Employee's spouse's mother or stepmother, father or stepfather, brother or sister, child or stepchild, grandparents, grandchildren, domestic partner, or any relative of the Employee or Employee's spouse residing in the same household. Such leave, up to 4 working days at one time [or 6 working days if travel outside of the following Counties is required: Imperial, Kern, Los Angeles, Orange, Riverside, San Bernardino, San Diego, Santa Barbara, San Luis Obispo, and Ventura], shall not be charged against sick or other leave. If more than the maximum days of Bereavement Leave provided in this Section is granted at one time, that amount over the limit shall be charged against sick or other leave. For Employees assigned to 24 hours shifts, a "day" means 12 hours or 1/2 shift. In accordance with Assembly Bill 1949, employees will be entitled to take up to five (5) days of unpaid bereavement leave for spouse, child, parent, sibling, grandparent, grandchild, domestic partner, or parent-in-law. The 5 days is not an additional number. However, due to overlap with the existing Fringe Benefits Resolution's bereavement leave definition, employees may use a combination of leave balances and paid bereavement leave specified in this paragraph.

**Reproductive Loss.** In accordance with Senate Bill 848, employees who have worked for the City for at least 30 days and have suffered a reproductive loss event will be entitled to take up to five (5) days of unpaid protected leave. A reproductive loss event is defined as the day or, for a multi-day event, the final day of a failed adoption, failed surrogacy, miscarriage, stillbirth or an unsuccessful assisted reproduction. The 5 days must be taken within three months of the event. Employees may use a combination of leave balances and paid bereavement leave specified in the paragraph above.

## **SECTION 25. MANAGEMENT LEAVE**

Executive and Management Employees shall be provided between 10 and 80 hours of Management Leave per fiscal year on a pro-rata basis as determined by the City Manager. This determination shall be based upon work circumstances, needs of the position, and frequency of required attendance at after-hour meetings and conferences. Such leave time is not accumulative. When through work circumstances and needs of the job, an Employee has been unable to utilize Management Leave and this has not been a pattern or practice for that Employee, the City Manager, for good cause, may approve excess accumulated Management Leave carried forward in the next fiscal year. Otherwise, any unused Management Leave hours shall automatically be cashed out to the Employee at the end of each Fiscal Year.

## **SECTION 26. WORKERS' COMPENSATION**

In those instances where an Executive, Management, or Confidential Employee is injured on duty and the injury is so recognized by the Workers' Compensation Act, the City of Arcadia, or the Workers' Compensation Appeal Board, such Employee shall be paid a combination of Workers' Compensation benefits and salary which will result in payment to the Employee of a sum equal to gross base salary. This sum will be paid for such time as the Employee is absent from duty because of such injury up to a maximum of one year

for Executive and Management and 10 months for Confidential Employees from and after the date of such injury. Lost time due to an injury on duty shall not be charged against an Employee's accumulated sick leave.

**SECTION 27.        JURY LEAVE**

When an Employee is called or required to serve as a juror, attendance shall be deemed a leave of absence with full pay for up to 10 days per year. All days in excess of 10 days will not be compensated. The Employee shall remit to the City all fees received except mileage. For Employees assigned to an alternate workweek, pay for jury duty shall not be provided on regularly scheduled days off. The Employee shall be entitled to keep the fee paid for scheduled days off. Employees on Jury Service shall provide documentation that verifies attendance. If, after reporting for Jury Service, it is determined that the Employee's services are not required and the Employee is dismissed for the day, then the Employee, time permitting, is required to return to the job. Employees who cannot verify Jury Service attendance and Employees who do not return to work shall be subject to disciplinary action.

**SECTION 28.        COURT WITNESS LEAVE**

An Employee who is subpoenaed or required to appear in court as a witness shall be deemed to be on leave of absence. With approval of the appointing power and City Manager, an Employee may be granted leave with pay during their required absence. The Employee shall remit to the City fees received except mileage. A paid leave of absence shall not be granted for time spent in Court on personal cases.

**SECTION 29.        MILITARY LEAVE**

Any employee who is a member of the reserve corps of the Armed Forces of the United States or of the National Guard or the Naval Militia is entitled to a temporary military leave of absence as provided by applicable Federal Law and California State Law.

**SECTION 30.        LEAVE DONATIONS – INJURY/ILLNESS/DISABILITY**

- A.     Upon verification of information from a medical authority that an Employee or an Employee's family dependent living within their household, or the Employee's minor child, has been stricken by a serious/catastrophic illness or injury, and upon verification that the Employee is in danger of having their accumulated paid leave time depleted, an Employee may request, and the appointing power and City Manager may determine that an Employee is eligible to receive donations of accumulated vacation/compensatory time.
- B.     Upon determination that an Employee is eligible, a notice shall be distributed to all Employees advising that accumulated vacation leave or compensatory time hours may be donated to the eligible Employee.

- C. The minimum number of hours that may be donated by an Employee is 1 hour. The maximum donation by the Employee is 80 hours. Only full-hour increments of leave time are transferable. Donation of time is limited to accrued vacation or compensatory time, and does not include accrued sick leave, holidays, or any other accumulated leave.
- D. The Employee to whom the vacation/compensatory time is donated will be credited at the salary rate of the recipient, not the donor. Donated hours shall be converted to the dollar rate of the donor then transferred to hours at the recipient's rate.
- E. The donation of leave hours is irreversible. However, should the person receiving the donation not use all donated leave for the catastrophic illness/injury, the donor will not be charged for any unused hours.
- F. An Employee may not donate leave hours which would reduce their own total accrued leave balance of vacation, compensatory time, sick leave, and management leave to less than 160 hours.
- G. If any Employee is caring for a family dependent living within their household, or the Employee's minor child, their time away from work on donated leave shall not exceed 12 weeks in a 12 month period. A 12 month period is defined as a rolling period measured backward from the date leave is taken and continuous with each additional leave day taken.

**SECTION 31. LEAVE DEDUCTIONS**

Executive, Management, and Confidential Employees shall be deducted leave time (either sick, vacation, floating holiday, or management leave as appropriate) for absences from work for periods of less than a day (a full daily shift).

**SECTION 32. HOLIDAYS**

- A. Executive, Management, and Confidential Employees other than Fire Safety Management Employees shall be allowed 8 hours (unless otherwise stated) of full pay for the following holidays:

New Year's Day	January 1
Martin Luther King Jr. Day	The third Monday in January
President's Day	The third Monday in February
Memorial Day	The last Monday in May
Independence Day	July 4
Labor Day	The first Monday in September
Veteran's Day	November 11
Thanksgiving Day	The fourth Thursday in November
Day after Thanksgiving Day	The Friday following the fourth

Christmas Eve	Thursday in November
Christmas Day	December 24
New Year's Eve	December 25
Floating Holiday	December 31
Floating Holiday	In lieu of Admission Day (not assigned to a specific holiday)

Every day appointed by the City Council for a public fast, thanksgiving, or holiday.

- B. Whenever New Year's Day (January 1) Independence Day (July 4), Veteran's Day (November 11), Christmas Eve (December 24), Christmas Day (December 25), or New Year's Eve (December 31) falls on a Saturday or Sunday, the Friday preceding or the Monday following, respectively, shall be designated as the holiday.
- C. Floating holidays are to be scheduled by the Employee in the same manner as vacation leave and do not carry over into subsequent fiscal years. Failure to timely schedule the days off shall result in their loss.
- D. Full-time Employees in the Executive, Management, and Confidential unit employed on July 1 of the fiscal year shall conditionally accrue 8 hours of floating holiday for the aforementioned Holidays. If the Employee uses floating holiday leave and separates from City employment before the date upon which the floating holiday is designated (Admission Day), said floating holiday leave shall be repaid to the City through payroll deduction or deducted from the Employee's vacation leave bank. Employees hired after the beginning of the fiscal year shall accrue floating holidays only if the Employee is employed before the date on which the floating holiday is based (Admission Day). As an example, an Employee hired on July 15, would receive a floating holiday for Admission Day for that fiscal year. However, if that same Employee was hired on March 15, the Employee would not receive any floating holiday benefit for that fiscal year.
- E. A non-exempt Employee required to work or attend a class or function on any holiday allowed by this Section shall be paid for the holiday, and in addition, shall be compensated in accordance with the Fair Labor Standards Act (FLSA) applicable overtime rules in calculating regular rate of pay. The regular rate of pay calculation includes Longevity Pay. A holiday allowed by this Section occurring during any leave of absence shall be added to the number of working days' leave of absence to which such Employee is entitled.
- F. Executive Management, and Confidential Employees assigned to an alternate workweek may use accrued vacation time, accrued compensatory time, floating holiday time, or unpaid leave to make up the difference between the provided

hours of holiday pay and the actual number of regularly scheduled working hours for a designated holiday.

- G. Executive, Management, and Confidential Employees who are assigned to an alternate work schedule shall receive 1 extra hour of holiday for any holiday that falls on a scheduled workday of 9 hours or more. For example, if a holiday falls on a day that an Employee is scheduled to work 9 hours, the Employee shall receive 9 hours of holiday pay.
- H. Management Employees assigned to the Fire Department and working a 56-hour workweek shall be limited to allow the following 12 hour holidays:

New Year's Day	Labor Day
Martin Luther King Jr. Day	Admission Day
President's Day	Columbus Day
Cesar Chavez Day	Thanksgiving Day
Independence Day	The Day After Thanksgiving
Labor Day	Christmas

In lieu of time off, the position of Battalion Chief working a 56-hour workweek shall receive 144 hours of regular rate of pay.

- I. The positions of Police Captain and Police Lieutenant have the option of receiving up to 17 hours of floating holiday pay in cash in lieu of taking the time off.

### **SECTION 33. SEVERANCE PAY**

- A. An Employee, with the exception of temporary appointments and Department Directors, whose position is abolished or vacated by a reduction in workload or lack of funds, and has at least 1 year of consecutive full-time service with the City shall receive, upon termination, severance pay. Severance pay shall be a lump sum payment equal to 1/5<sup>th</sup> of an Employee's previous month's salary times the number of years of consecutive service, not to exceed 10 years of service. Additionally, the City shall: 1) contract with a mental health carrier to provide transitional counseling services to affected Employees for up to 3 months; and 2) contract with a displacement service provider to provide professional guidance and assistance for the laid off Employee in their employment search for up to 3 months. The displaced Employee shall also receive one full month of paid health insurance (at the Employee's current coverage) in addition to any coverage remaining in the month of layoff.
- B. A Department Director whose position is abolished or vacated by a reduction in workload or lack of funds, or who is involuntarily removed from their position and has at least 1 year of consecutive full-time service with the City may receive, upon termination, severance pay. Severance pay as authorized by the City Manager, shall be a lump sum payment, and can be any amount up to 6 months' salary. The

displaced Employee shall also receive paid health insurance (at the Employee's current coverage) in addition to any coverage remaining in the month of layoff or termination. The amount of paid health insurance coverage shall be equal to the length of the severance pay that was granted under this paragraph. At the discretion of the City Council, the severance pay and continuation of health benefits may be increased for an additional period of time.

**SECTION 34. WORKDAY SCHEDULES**

A workday shall be defined as an 8-hour period for all City Employees, with the exception that Fire Employees assigned to 24-hour shift; a day means a 12-hour period. A workday may be defined differently if an Employee is assigned to an alternative work schedule. An Employee who changes between an 8-hour and a 12-hour day shall have leave hours recalculated on the basis of the number of hours worked.

**SECTION 35. Y-RATING – MANAGEMENT EMPLOYEES**

Y-Rating occurs when a position is reclassified to a lower salary range and where an incumbent Employee continues to hold their current salary until the "Y-rating" process brings the Employee's salary to the top step of the new salary range for that position. Y-rating shall not be permissible for Executive Management Employees.

If a Y-Rated salary of an Employee is greater than 7.5% higher than the top step of a newly-established salary range, then the Y-Rated salary shall be reduced by up to 5% the first pay period in January, and up to 5% the first pay period in July, until the range of the Y-Rated salary is 7.5% greater than the top step of the new salary range. The Y-Rated salary range of an Employee that is 7.5% or less greater than the top step of the newly-established salary range shall not receive any adjustment until such time that the top step of the new salary range is greater than the Y-Rated salary range.

**SECTION 36. SICK LEAVE FOR PART TIME UNREPRESENTED EMPLOYEES, INCLUDING LAW ENFORCEMENT RECRUITS AND FIREFIGHTER RECRUITS**

A. Part-Time Unrepresented Employees, including Law Enforcement Recruits and Firefighter Recruits, shall accrue sick leave beginning with the first full pay period of employment on the basis of 1 hour for every 30 hours worked. The maximum accrual per year is 80 hours.

Paid sick leave will carry over each year of employment however an employee may only accumulate up to a maximum of 80 hours or 10 days, whichever is greater depending on the employee's regular scheduled workday, of sick leave with pay.

B. If an employee separates from employment and is rehired within one year from separation, up to 80 hours or 10 days, whichever is greater depending on the

employee's regular scheduled workday, of accrued and unused sick leave will be reinstated.

- C. A waiting period of 90 days is required before an employee may be eligible to use paid sick leave. An employee who is rehired within one year from their date of separation, and who worked at least 90 days in the initial employment with the City may immediately use reinstated sick leave. An employee who had not worked 90 days in the initial employment with the City must work the remaining amount of the 90 day qualifying period to be able to use accrued sick leave with pay.
- D. If paid sick leave is taken for the diagnosis, care, or treatment of an existing health condition of, or preventive care of an employee or an employee's family member, the City Manager or designee may require an employee to provide medical certification or evidence of the reason for a sick leave absence that occurs after the employee has used the first 40 hours or 5 days, whichever is greater depending on the employee's regular scheduled workday, of paid sick leave in a year of employment. The City Manager or designee may require a medical examination by a physician after the employee has used the first 40 hours or 5 days, whichever is greater depending on the employee's regular scheduled workday, of paid sick leave in a year of employment if the medical examination is job related and consistent with business necessity

For leave pertaining to an employee who is a victim of domestic violence, sexual assault, or stalking, the City Manager or designee may request certification for unscheduled absences beginning on the first day of paid sick leave.

- E. Sick leave means paid authorized absence from duty of an Employee who is temporarily disabled and unable to work due to one of the following:
  - 1. Diagnosis, care, or treatment of an existing health condition of, or preventative care for, an employee
  - 2. Diagnosis, care, or treatment of an existing health condition of, or preventative care for, an employee's family member, which includes parent (biological, adoptive, foster parent, step parent, legal guardian, or a person who stood loco parentis when employee was a child), child (biological, adoptive, foster child, step child, legal ward, or a child to whom the employee stands loco parentis regardless of age or dependency status), spouse, registered domestic partner, parent-in-law, sibling, grandchild, or grandparent
  - 3. For an employee who is a victim of domestic violence, sexual assault, or stalking for the purposes described in Labor Code sections 230(c) and 230.1 (a); and/or,
  - 4. An employee may designate one additional person per 12-month period at the time the employee requested sick leave.

An employee will make a reasonable effort to schedule medical appointments during non-working hours.

- F. Kin Care Leave: In addition to the prescribed purposes of paid sick leave in Section d. an employee may use up to one-half of his/her annual accrual of sick leave to care for and attend to a family member who is ill. Every effort shall be made to schedule medical appointments for an ill family member during non-working hours. Family members for purposes of Kin Care leave shall include parent (biological, adoptive, foster parent, step parent, or legal guardian), child (biological, adoptive, foster child, step child, legal ward, a child of a registered domestic partner, or a child to whom the employee stands loco parentis regardless of age or dependency), spouse, or registered domestic partner, and an employee may designate one additional person per 12-month period at the time the employee requested sick leave.
- G. In case of absence due to illness, if the paid sick leave is foreseeable, the Employee shall notify their supervisor within reasonable advance notice. If the paid sick leave is unforeseeable, the employee shall provide notice of the need for the leave as soon as possible. The minimum increment of use of paid sick leave shall be 30 minutes. Employee's use of sick leave will be limited to 40 hours per year.
- H. The appointing power and City Manager may discipline an employee if sick leave is used for an inappropriate purpose.
- I. Upon separation from the City of Arcadia, an employee who works in their final pay period, shall receive credit for that pay period's sick leave accrual based on the following:

0 to 29 hours:	No accrual
30 to 59 hours:	1 hour
60 to 80 hours:	2 hours

Unused sick leave is not cashed out upon termination, resignation, retirement, or other separation from employment.

**SECTION 37. FRINGE BENEFITS – ELIGIBILITY**

The City Council, Executive, Management, Confidential Employees, and Unrepresented benefitted Employees, as defined in Section 2 (including only those Employees who at minimum receive CalPERS Retirement Benefits and Health Insurance contributions) not represented by a recognized Employee organization, with the exception of temporary appointments, shall be entitled to receive the benefits provided by the City of Arcadia as specified in the Resolution adopting said benefits.

Part-Time Unrepresented Employees as defined in Section 2 shall be entitled to receive the sick leave benefits as provided in Section 36.

**SECTION 38.        AMENDMENTS**

Any modifications or amendments to the terms of this Resolution shall be implemented by a City Council approved Resolution directing inclusion of the modification or amendment as part of this Resolution.

**EXHIBIT A  
CITY OF ARCADIA MONTHLY SALARY RANGE  
JULY 1, 2024 - JUNE 30, 2025**

**EXECUTIVE MANAGEMENT**

Title	Step A	Step B	Step C	Step D	Step E	Step F	Step G	Step H	Step I	Step J
Administrative Services Director	\$ 14,947	\$ 15,319	\$ 15,705	\$ 16,097	\$ 16,500	\$ 16,911	\$ 17,333	\$ 17,766	\$ 18,215	\$ 18,667
Assistant City Manager/ Development Services Director	\$ 18,844	\$ 19,315	\$ 19,798	\$ 20,293	\$ 20,801	\$ 21,321	\$ 21,854	\$ 22,400	\$ 22,960	\$ 23,534
Director of Library & Museum Services	\$ 14,947	\$ 15,319	\$ 15,705	\$ 16,097	\$ 16,500	\$ 16,911	\$ 17,333	\$ 17,766	\$ 18,215	\$ 18,667
Director of Recreation & Community Services	\$ 14,947	\$ 15,319	\$ 15,705	\$ 16,097	\$ 16,500	\$ 16,911	\$ 17,333	\$ 17,766	\$ 18,215	\$ 18,667
Human Resources Director	\$ 14,947	\$ 15,319	\$ 15,705	\$ 16,097	\$ 16,500	\$ 16,911	\$ 17,333	\$ 17,766	\$ 18,215	\$ 18,667
Public Works Services Director	\$ 15,202	\$ 15,582	\$ 15,972	\$ 16,371	\$ 16,780	\$ 17,200	\$ 17,630	\$ 18,071	\$ 18,522	\$ 18,985

**SAFETY EXECUTIVE MANAGEMENT**

Fire Chief	\$ 18,804	\$ 19,275	\$ 19,756	\$ 20,250	\$ 20,757	\$ 21,275	\$ 21,807	\$ 22,353	\$ 22,911	\$ 23,484
Police Chief	\$ 18,804	\$ 19,275	\$ 19,756	\$ 20,250	\$ 20,757	\$ 21,275	\$ 21,807	\$ 22,353	\$ 22,911	\$ 23,484

*Salaries are effective the beginning of the pay period containing July 1, 2024*

**EXHIBIT A  
CITY OF ARCADIA MONTHLY SALARY RANGE  
JULY 1, 2025 - JUNE 30, 2026**

**EXECUTIVE MANAGEMENT**

Title	Step A	Step B	Step C	Step D	Step E	Step F	Step G	Step H	Step I	Step J
Administrative Services Director	\$ 15,844	\$ 16,238	\$ 16,647	\$ 17,063	\$ 17,490	\$ 17,926	\$ 18,373	\$ 18,832	\$ 19,308	\$ 19,787
Assistant City Manager/ Development Services Director	\$ 19,968	\$ 20,467	\$ 20,979	\$ 21,503	\$ 22,041	\$ 22,592	\$ 23,156	\$ 23,735	\$ 24,329	\$ 24,937
Director of Library & Museum Services	\$ 15,844	\$ 16,238	\$ 16,647	\$ 17,063	\$ 17,490	\$ 17,926	\$ 18,373	\$ 18,832	\$ 19,308	\$ 19,787
Director of Recreation & Community Services	\$ 15,844	\$ 16,238	\$ 16,647	\$ 17,063	\$ 17,490	\$ 17,926	\$ 18,373	\$ 18,832	\$ 19,308	\$ 19,787
Human Resources Director	\$ 15,844	\$ 16,238	\$ 16,647	\$ 17,063	\$ 17,490	\$ 17,926	\$ 18,373	\$ 18,832	\$ 19,308	\$ 19,787
Public Works Services Director	\$ 16,114	\$ 16,517	\$ 16,930	\$ 17,353	\$ 17,787	\$ 18,232	\$ 18,688	\$ 19,155	\$ 19,634	\$ 20,125

**SAFETY EXECUTIVE MANAGEMENT**

Fire Chief	\$ 19,933	\$ 20,431	\$ 20,942	\$ 21,465	\$ 22,002	\$ 22,552	\$ 23,116	\$ 23,694	\$ 24,286	\$ 24,893
Police Chief	\$ 19,933	\$ 20,431	\$ 20,942	\$ 21,465	\$ 22,002	\$ 22,552	\$ 23,116	\$ 23,694	\$ 24,286	\$ 24,893

*Salaries are effective the beginning of the pay period containing July 1, 2025*

**EXHIBIT A  
CITY OF ARCADIA MONTHLY SALARY RANGE  
JULY 1, 2026 - JUNE 30, 2027**

**EXECUTIVE MANAGEMENT**

Title	Step A	Step B	Step C	Step D	Step E	Step F	Step G	Step H	Step I	Step J
Administrative Services Director	\$ 16,636	\$ 17,050	\$ 17,479	\$ 17,916	\$ 18,365	\$ 18,822	\$ 19,292	\$ 19,774	\$ 20,273	\$ 20,776
Assistant City Manager/ Development Services Director	\$ 20,974	\$ 21,499	\$ 22,036	\$ 22,587	\$ 23,152	\$ 23,730	\$ 24,324	\$ 24,932	\$ 25,555	\$ 26,194
Director of Library & Museum Services	\$ 16,636	\$ 17,050	\$ 17,479	\$ 17,916	\$ 18,365	\$ 18,822	\$ 19,292	\$ 19,774	\$ 20,273	\$ 20,776
Director of Recreation & Community Services	\$ 16,636	\$ 17,050	\$ 17,479	\$ 17,916	\$ 18,365	\$ 18,822	\$ 19,292	\$ 19,774	\$ 20,273	\$ 20,776
Human Resources Director	\$ 16,636	\$ 17,050	\$ 17,479	\$ 17,916	\$ 18,365	\$ 18,822	\$ 19,292	\$ 19,774	\$ 20,273	\$ 20,776
Public Works Services Director	\$ 16,920	\$ 17,343	\$ 17,777	\$ 18,221	\$ 18,676	\$ 19,144	\$ 19,622	\$ 20,113	\$ 20,616	\$ 21,131

**SAFETY EXECUTIVE MANAGEMENT**

Fire Chief	\$ 20,930	\$ 21,453	\$ 21,989	\$ 22,538	\$ 23,102	\$ 23,680	\$ 24,272	\$ 24,879	\$ 25,500	\$ 26,138
Police Chief	\$ 20,930	\$ 21,453	\$ 21,989	\$ 22,538	\$ 23,102	\$ 23,680	\$ 24,272	\$ 24,879	\$ 25,500	\$ 26,138

*Salaries are effective the beginning of the pay period containing July 1, 2026*

**EXHIBIT A**  
**CITY OF ARCADIA MONTHLY SALARY RANGE**  
**JULY 1, 2024 - JUNE 30, 2025**  
**MANAGEMENT**

Title	Step A	Step B	Step C	Step D	Step E	Step F	Step G	Step H	Step I	Step J
Accountant	\$ 6,616	\$ 6,787	\$ 6,951	\$ 7,123	\$ 7,304	\$ 7,487	\$ 7,673	\$ 7,868	\$ 8,062	\$ 8,264
Accounting Supervisor	\$ 8,899	\$ 9,123	\$ 9,352	\$ 9,583	\$ 9,824	\$ 10,072	\$ 10,321	\$ 10,579	\$ 10,844	\$ 11,115
Assistant to the City Manager	\$ 9,583	\$ 9,824	\$ 10,072	\$ 10,321	\$ 10,579	\$ 10,844	\$ 11,115	\$ 11,394	\$ 11,678	\$ 11,969
Building Official	\$ 11,930	\$ 12,229	\$ 12,534	\$ 12,848	\$ 13,169	\$ 13,498	\$ 13,836	\$ 14,182	\$ 14,536	\$ 14,900
Buyer	\$ 5,996	\$ 6,145	\$ 6,298	\$ 6,457	\$ 6,616	\$ 6,787	\$ 6,951	\$ 7,123	\$ 7,304	\$ 7,487
City Clerk	\$ 8,469	\$ 8,682	\$ 8,899	\$ 9,123	\$ 9,352	\$ 9,583	\$ 9,824	\$ 10,072	\$ 10,321	\$ 10,579
City Engineer	\$ 11,930	\$ 12,229	\$ 12,534	\$ 12,848	\$ 13,169	\$ 13,498	\$ 13,836	\$ 14,182	\$ 14,536	\$ 14,900
Communication and Engagement Officer	\$ 8,264	\$ 8,469	\$ 8,682	\$ 8,899	\$ 9,123	\$ 9,352	\$ 9,583	\$ 9,824	\$ 10,072	\$ 10,321
Crime Analyst/Investigative Support Specialist	\$ 7,487	\$ 7,673	\$ 7,868	\$ 8,062	\$ 8,264	\$ 8,469	\$ 8,682	\$ 8,899	\$ 9,123	\$ 9,352
Deputy City Manager	\$ 11,969	\$ 12,270	\$ 12,576	\$ 12,891	\$ 13,212	\$ 13,545	\$ 13,882	\$ 14,231	\$ 14,584	\$ 14,947
Deputy Development Services Director	\$ 13,123	\$ 13,452	\$ 13,788	\$ 14,133	\$ 14,486	\$ 14,848	\$ 15,219	\$ 15,600	\$ 15,990	\$ 16,389
Deputy Director of Recreation and Community Services	\$ 11,930	\$ 12,229	\$ 12,534	\$ 12,848	\$ 13,169	\$ 13,498	\$ 13,836	\$ 14,182	\$ 14,536	\$ 14,900
Deputy Public Works Services Director	\$ 12,535	\$ 12,848	\$ 13,169	\$ 13,498	\$ 13,836	\$ 14,182	\$ 14,536	\$ 14,900	\$ 15,272	\$ 15,654
Economic Development Manager	\$ 10,579	\$ 10,844	\$ 11,115	\$ 11,394	\$ 11,678	\$ 11,969	\$ 12,270	\$ 12,576	\$ 12,891	\$ 13,212
Environmental Services Manager	\$ 8,264	\$ 8,469	\$ 8,682	\$ 8,899	\$ 9,123	\$ 9,352	\$ 9,583	\$ 9,824	\$ 10,072	\$ 10,321
Financial Services Manager/Treasurer	\$ 11,678	\$ 11,969	\$ 12,270	\$ 12,576	\$ 12,891	\$ 13,212	\$ 13,545	\$ 13,882	\$ 14,231	\$ 14,584
Fire Marshal	\$ 10,072	\$ 10,321	\$ 10,579	\$ 10,844	\$ 11,115	\$ 11,394	\$ 11,678	\$ 11,969	\$ 12,270	\$ 12,576
General Services Superintendent	\$ 9,583	\$ 9,824	\$ 10,072	\$ 10,321	\$ 10,579	\$ 10,844	\$ 11,115	\$ 11,394	\$ 11,678	\$ 11,969
Human Resources Administrator	\$ 11,678	\$ 11,969	\$ 12,270	\$ 12,576	\$ 12,891	\$ 13,212	\$ 13,545	\$ 13,882	\$ 14,231	\$ 14,584
Human Resources Analyst	\$ 7,304	\$ 7,487	\$ 7,673	\$ 7,868	\$ 8,062	\$ 8,264	\$ 8,469	\$ 8,682	\$ 8,899	\$ 9,123
Human Resources Manager	\$ 9,583	\$ 9,824	\$ 10,072	\$ 10,321	\$ 10,579	\$ 10,844	\$ 11,115	\$ 11,394	\$ 11,678	\$ 11,969
Information Technology Manager	\$ 9,824	\$ 10,072	\$ 10,321	\$ 10,579	\$ 10,844	\$ 11,115	\$ 11,394	\$ 11,678	\$ 11,969	\$ 12,270
Library Services Manager	\$ 9,583	\$ 9,824	\$ 10,072	\$ 10,321	\$ 10,579	\$ 10,844	\$ 11,115	\$ 11,394	\$ 11,678	\$ 11,969
Management Aide	\$ 5,848	\$ 5,996	\$ 6,145	\$ 6,298	\$ 6,457	\$ 6,616	\$ 6,787	\$ 6,951	\$ 7,123	\$ 7,304
Management Analyst	\$ 7,487	\$ 7,673	\$ 7,868	\$ 8,062	\$ 8,264	\$ 8,469	\$ 8,682	\$ 8,899	\$ 9,123	\$ 9,352
Planning Services Manager	\$ 9,583	\$ 9,824	\$ 10,072	\$ 10,321	\$ 10,579	\$ 10,844	\$ 11,115	\$ 11,394	\$ 11,678	\$ 11,969
Police Records Manager	\$ 8,264	\$ 8,469	\$ 8,682	\$ 8,899	\$ 9,123	\$ 9,352	\$ 9,583	\$ 9,824	\$ 10,072	\$ 10,321
Principal Civil Engineer	\$ 10,844	\$ 11,115	\$ 11,394	\$ 11,678	\$ 11,969	\$ 12,270	\$ 12,576	\$ 12,891	\$ 13,212	\$ 13,545
Project Manager	\$ 9,352	\$ 9,583	\$ 9,824	\$ 10,072	\$ 10,321	\$ 10,579	\$ 10,844	\$ 11,115	\$ 11,394	\$ 11,678
Purchasing Officer	\$ 6,787	\$ 6,951	\$ 7,123	\$ 7,304	\$ 7,487	\$ 7,673	\$ 7,868	\$ 8,062	\$ 8,264	\$ 8,469
Recreation Supervisor	\$ 6,616	\$ 6,787	\$ 6,951	\$ 7,123	\$ 7,304	\$ 7,487	\$ 7,673	\$ 7,868	\$ 8,062	\$ 8,264
Senior Accountant	\$ 7,673	\$ 7,868	\$ 8,062	\$ 8,264	\$ 8,469	\$ 8,682	\$ 8,899	\$ 9,123	\$ 9,352	\$ 9,583
Senior Human Resources Analyst	\$ 8,264	\$ 8,469	\$ 8,682	\$ 8,899	\$ 9,123	\$ 9,352	\$ 9,583	\$ 9,824	\$ 10,072	\$ 10,321
Senior Management Analyst	\$ 8,264	\$ 8,469	\$ 8,682	\$ 8,899	\$ 9,123	\$ 9,352	\$ 9,583	\$ 9,824	\$ 10,072	\$ 10,321
Streets Superintendent	\$ 9,583	\$ 9,824	\$ 10,072	\$ 10,321	\$ 10,579	\$ 10,844	\$ 11,115	\$ 11,394	\$ 11,678	\$ 11,969
Transportation Services Manager	\$ 8,264	\$ 8,469	\$ 8,682	\$ 8,899	\$ 9,123	\$ 9,352	\$ 9,583	\$ 9,824	\$ 10,072	\$ 10,321
Utilities Manager	\$ 11,394	\$ 11,678	\$ 11,969	\$ 12,270	\$ 12,576	\$ 12,891	\$ 13,212	\$ 13,545	\$ 13,882	\$ 14,231

Salaries are effective the beginning of the pay period containing July 1, 2024

**EXHIBIT A  
CITY OF ARCADIA MONTHLY SALARY RANGE  
JULY 1, 2025 - JUNE 30, 2026  
MANAGEMENT**

Title	Step A	Step B	Step C	Step D	Step E	Step F	Step G	Step H	Step I	Step J
Accountant	\$ 7,013	\$ 7,194	\$ 7,368	\$ 7,550	\$ 7,742	\$ 7,936	\$ 8,133	\$ 8,340	\$ 8,546	\$ 8,760
Accounting Supervisor	\$ 9,433	\$ 9,670	\$ 9,913	\$ 10,158	\$ 10,413	\$ 10,676	\$ 10,940	\$ 11,214	\$ 11,495	\$ 11,782
Assistant to the City Manager	\$ 10,158	\$ 10,413	\$ 10,676	\$ 10,940	\$ 11,214	\$ 11,495	\$ 11,782	\$ 12,078	\$ 12,379	\$ 12,687
Building Official	\$ 12,646	\$ 12,962	\$ 13,287	\$ 13,619	\$ 13,959	\$ 14,308	\$ 14,666	\$ 15,032	\$ 15,408	\$ 15,793
Buyer	\$ 6,356	\$ 6,514	\$ 6,676	\$ 6,844	\$ 7,013	\$ 7,194	\$ 7,368	\$ 7,550	\$ 7,742	\$ 7,936
City Clerk	\$ 8,977	\$ 9,203	\$ 9,433	\$ 9,670	\$ 9,913	\$ 10,158	\$ 10,413	\$ 10,676	\$ 10,940	\$ 11,214
City Engineer	\$ 12,646	\$ 12,962	\$ 13,287	\$ 13,619	\$ 13,959	\$ 14,308	\$ 14,666	\$ 15,032	\$ 15,408	\$ 15,793
Communication and Engagement Officer	\$ 8,760	\$ 8,977	\$ 9,203	\$ 9,433	\$ 9,670	\$ 9,913	\$ 10,158	\$ 10,413	\$ 10,676	\$ 10,940
Crime Analyst/Investigative Support Specialist	\$ 7,936	\$ 8,133	\$ 8,340	\$ 8,546	\$ 8,760	\$ 8,977	\$ 9,203	\$ 9,433	\$ 9,670	\$ 9,913
Deputy City Manager	\$ 12,687	\$ 13,006	\$ 13,331	\$ 13,664	\$ 14,005	\$ 14,358	\$ 14,715	\$ 15,085	\$ 15,459	\$ 15,844
Deputy Development Services Director	\$ 13,911	\$ 14,259	\$ 14,615	\$ 14,981	\$ 15,355	\$ 15,739	\$ 16,132	\$ 16,536	\$ 16,949	\$ 17,373
Deputy Director of Recreation and Community Services	\$ 12,646	\$ 12,962	\$ 13,287	\$ 13,619	\$ 13,959	\$ 14,308	\$ 14,666	\$ 15,032	\$ 15,408	\$ 15,793
Deputy Public Works Services Director	\$ 13,287	\$ 13,619	\$ 13,959	\$ 14,308	\$ 14,666	\$ 15,033	\$ 15,409	\$ 15,794	\$ 16,189	\$ 16,593
Economic Development Manager	\$ 11,214	\$ 11,495	\$ 11,782	\$ 12,078	\$ 12,379	\$ 12,687	\$ 13,006	\$ 13,331	\$ 13,664	\$ 14,005
Environmental Services Manager	\$ 8,760	\$ 8,977	\$ 9,203	\$ 9,433	\$ 9,670	\$ 9,913	\$ 10,158	\$ 10,413	\$ 10,676	\$ 10,940
Financial Services Manager/Treasurer	\$ 12,379	\$ 12,687	\$ 13,006	\$ 13,331	\$ 13,664	\$ 14,005	\$ 14,358	\$ 14,715	\$ 15,085	\$ 15,459
Fire Marshal	\$ 10,676	\$ 10,940	\$ 11,214	\$ 11,495	\$ 11,782	\$ 12,078	\$ 12,379	\$ 12,687	\$ 13,006	\$ 13,331
General Services Superintendent	\$ 10,158	\$ 10,413	\$ 10,676	\$ 10,940	\$ 11,214	\$ 11,495	\$ 11,782	\$ 12,078	\$ 12,379	\$ 12,687
Human Resources Administrator	\$ 12,379	\$ 12,687	\$ 13,006	\$ 13,331	\$ 13,664	\$ 14,005	\$ 14,358	\$ 14,715	\$ 15,085	\$ 15,459
Human Resources Analyst	\$ 7,742	\$ 7,936	\$ 8,133	\$ 8,340	\$ 8,546	\$ 8,760	\$ 8,977	\$ 9,203	\$ 9,433	\$ 9,670
Human Resources Manager	\$ 10,158	\$ 10,413	\$ 10,676	\$ 10,940	\$ 11,214	\$ 11,495	\$ 11,782	\$ 12,078	\$ 12,379	\$ 12,687
Information Technology Manager	\$ 10,413	\$ 10,676	\$ 10,940	\$ 11,214	\$ 11,495	\$ 11,782	\$ 12,078	\$ 12,379	\$ 12,687	\$ 13,006
Library Services Manager	\$ 10,158	\$ 10,413	\$ 10,676	\$ 10,940	\$ 11,214	\$ 11,495	\$ 11,782	\$ 12,078	\$ 12,379	\$ 12,687
Management Aide	\$ 6,199	\$ 6,356	\$ 6,514	\$ 6,676	\$ 6,844	\$ 7,013	\$ 7,194	\$ 7,368	\$ 7,550	\$ 7,742
Management Analyst	\$ 7,936	\$ 8,133	\$ 8,340	\$ 8,546	\$ 8,760	\$ 8,977	\$ 9,203	\$ 9,433	\$ 9,670	\$ 9,913
Planning Services Manager	\$ 10,158	\$ 10,413	\$ 10,676	\$ 10,940	\$ 11,214	\$ 11,495	\$ 11,782	\$ 12,078	\$ 12,379	\$ 12,687
Police Records Manager	\$ 8,760	\$ 8,977	\$ 9,203	\$ 9,433	\$ 9,670	\$ 9,913	\$ 10,158	\$ 10,413	\$ 10,676	\$ 10,940
Principal Civil Engineer	\$ 11,495	\$ 11,782	\$ 12,078	\$ 12,379	\$ 12,687	\$ 13,006	\$ 13,331	\$ 13,664	\$ 14,005	\$ 14,358
Project Manager	\$ 9,913	\$ 10,158	\$ 10,413	\$ 10,676	\$ 10,940	\$ 11,214	\$ 11,495	\$ 11,782	\$ 12,078	\$ 12,379
Purchasing Officer	\$ 7,194	\$ 7,368	\$ 7,550	\$ 7,742	\$ 7,936	\$ 8,133	\$ 8,340	\$ 8,546	\$ 8,760	\$ 8,977
Recreation Supervisor	\$ 7,013	\$ 7,194	\$ 7,368	\$ 7,550	\$ 7,742	\$ 7,936	\$ 8,133	\$ 8,340	\$ 8,546	\$ 8,760
Senior Accountant	\$ 8,133	\$ 8,340	\$ 8,546	\$ 8,760	\$ 8,977	\$ 9,203	\$ 9,433	\$ 9,670	\$ 9,913	\$ 10,158
Senior Human Resources Analyst	\$ 8,760	\$ 8,977	\$ 9,203	\$ 9,433	\$ 9,670	\$ 9,913	\$ 10,158	\$ 10,413	\$ 10,676	\$ 10,940
Senior Management Analyst	\$ 8,760	\$ 8,977	\$ 9,203	\$ 9,433	\$ 9,670	\$ 9,913	\$ 10,158	\$ 10,413	\$ 10,676	\$ 10,940
Streets Superintendent	\$ 10,158	\$ 10,413	\$ 10,676	\$ 10,940	\$ 11,214	\$ 11,495	\$ 11,782	\$ 12,078	\$ 12,379	\$ 12,687
Transportation Services Manager	\$ 8,760	\$ 8,977	\$ 9,203	\$ 9,433	\$ 9,670	\$ 9,913	\$ 10,158	\$ 10,413	\$ 10,676	\$ 10,940
Utilities Manager	\$ 12,078	\$ 12,379	\$ 12,687	\$ 13,006	\$ 13,331	\$ 13,664	\$ 14,005	\$ 14,358	\$ 14,715	\$ 15,085

Salaries are effective the beginning of the pay period containing July 1, 2025

**EXHIBIT A  
CITY OF ARCADIA MONTHLY SALARY RANGE  
JULY 1, 2026 - JUNE 30, 2027  
MANAGEMENT**

Title	Step A	Step B	Step C	Step D	Step E	Step F	Step G	Step H	Step I	Step J
Accountant	\$ 7,364	\$ 7,554	\$ 7,736	\$ 7,928	\$ 8,129	\$ 8,333	\$ 8,540	\$ 8,757	\$ 8,973	\$ 9,198
Accounting Supervisor	\$ 9,905	\$ 10,154	\$ 10,409	\$ 10,666	\$ 10,934	\$ 11,210	\$ 11,487	\$ 11,774	\$ 12,069	\$ 12,371
Assistant to the City Manager	\$ 10,666	\$ 10,934	\$ 11,210	\$ 11,487	\$ 11,774	\$ 12,069	\$ 12,371	\$ 12,682	\$ 12,998	\$ 13,322
Building Official	\$ 13,279	\$ 13,611	\$ 13,951	\$ 14,300	\$ 14,657	\$ 15,024	\$ 15,399	\$ 15,784	\$ 16,179	\$ 16,583
Buyer	\$ 6,674	\$ 6,839	\$ 7,010	\$ 7,187	\$ 7,364	\$ 7,554	\$ 7,736	\$ 7,928	\$ 8,129	\$ 8,333
City Clerk	\$ 9,426	\$ 9,663	\$ 9,905	\$ 10,154	\$ 10,409	\$ 10,666	\$ 10,934	\$ 11,210	\$ 11,487	\$ 11,774
City Engineer	\$ 13,279	\$ 13,611	\$ 13,951	\$ 14,300	\$ 14,657	\$ 15,024	\$ 15,399	\$ 15,784	\$ 16,179	\$ 16,583
Communication and Engagement Officer	\$ 9,198	\$ 9,426	\$ 9,663	\$ 9,905	\$ 10,154	\$ 10,409	\$ 10,666	\$ 10,934	\$ 11,210	\$ 11,487
Crime Analyst/Investigative Support Specialist	\$ 8,333	\$ 8,540	\$ 8,757	\$ 8,973	\$ 9,198	\$ 9,426	\$ 9,663	\$ 9,905	\$ 10,154	\$ 10,409
Deputy City Manager	\$ 13,322	\$ 13,657	\$ 13,997	\$ 14,348	\$ 14,705	\$ 15,076	\$ 15,451	\$ 15,839	\$ 16,232	\$ 16,636
Deputy Development Services Director	\$ 14,606	\$ 14,972	\$ 15,346	\$ 15,730	\$ 16,123	\$ 16,526	\$ 16,939	\$ 17,362	\$ 17,797	\$ 18,241
Deputy Director of Recreation and Community Services	\$ 13,279	\$ 13,611	\$ 13,951	\$ 14,300	\$ 14,657	\$ 15,024	\$ 15,399	\$ 15,784	\$ 16,179	\$ 16,583
Deputy Public Works Services Director	\$ 13,951	\$ 14,300	\$ 14,657	\$ 15,024	\$ 15,399	\$ 15,784	\$ 16,179	\$ 16,583	\$ 16,998	\$ 17,423
Economic Development Manager	\$ 11,774	\$ 12,069	\$ 12,371	\$ 12,682	\$ 12,998	\$ 13,322	\$ 13,657	\$ 13,997	\$ 14,348	\$ 14,705
Environmental Services Manager	\$ 9,198	\$ 9,426	\$ 9,663	\$ 9,905	\$ 10,154	\$ 10,409	\$ 10,666	\$ 10,934	\$ 11,210	\$ 11,487
Financial Services Manager/Treasurer	\$ 12,998	\$ 13,322	\$ 13,657	\$ 13,997	\$ 14,348	\$ 14,705	\$ 15,076	\$ 15,451	\$ 15,839	\$ 16,232
Fire Marshal	\$ 11,210	\$ 11,487	\$ 11,774	\$ 12,069	\$ 12,371	\$ 12,682	\$ 12,998	\$ 13,322	\$ 13,657	\$ 13,997
General Services Superintendent	\$ 10,666	\$ 10,934	\$ 11,210	\$ 11,487	\$ 11,774	\$ 12,069	\$ 12,371	\$ 12,682	\$ 12,998	\$ 13,322
Human Resources Administrator	\$ 12,998	\$ 13,322	\$ 13,657	\$ 13,997	\$ 14,348	\$ 14,705	\$ 15,076	\$ 15,451	\$ 15,839	\$ 16,232
Human Resources Analyst	\$ 8,129	\$ 8,333	\$ 8,540	\$ 8,757	\$ 8,973	\$ 9,198	\$ 9,426	\$ 9,663	\$ 9,905	\$ 10,154
Human Resources Manager	\$ 10,666	\$ 10,934	\$ 11,210	\$ 11,487	\$ 11,774	\$ 12,069	\$ 12,371	\$ 12,682	\$ 12,998	\$ 13,322
Information Technology Manager	\$ 10,934	\$ 11,210	\$ 11,487	\$ 11,774	\$ 12,069	\$ 12,371	\$ 12,682	\$ 12,998	\$ 13,322	\$ 13,657
Library Services Manager	\$ 10,666	\$ 10,934	\$ 11,210	\$ 11,487	\$ 11,774	\$ 12,069	\$ 12,371	\$ 12,682	\$ 12,998	\$ 13,322
Management Aide	\$ 6,509	\$ 6,674	\$ 6,839	\$ 7,010	\$ 7,187	\$ 7,364	\$ 7,554	\$ 7,736	\$ 7,928	\$ 8,129
Management Analyst	\$ 8,333	\$ 8,540	\$ 8,757	\$ 8,973	\$ 9,198	\$ 9,426	\$ 9,663	\$ 9,905	\$ 10,154	\$ 10,409
Planning Services Manager	\$ 10,666	\$ 10,934	\$ 11,210	\$ 11,487	\$ 11,774	\$ 12,069	\$ 12,371	\$ 12,682	\$ 12,998	\$ 13,322
Police Records Manager	\$ 9,198	\$ 9,426	\$ 9,663	\$ 9,905	\$ 10,154	\$ 10,409	\$ 10,666	\$ 10,934	\$ 11,210	\$ 11,487
Principal Civil Engineer	\$ 12,069	\$ 12,371	\$ 12,682	\$ 12,998	\$ 13,322	\$ 13,657	\$ 13,997	\$ 14,348	\$ 14,705	\$ 15,076
Project Manager	\$ 10,409	\$ 10,666	\$ 10,934	\$ 11,210	\$ 11,487	\$ 11,774	\$ 12,069	\$ 12,371	\$ 12,682	\$ 12,998
Purchasing Officer	\$ 7,554	\$ 7,736	\$ 7,928	\$ 8,129	\$ 8,333	\$ 8,540	\$ 8,757	\$ 8,973	\$ 9,198	\$ 9,426
Recreation Supervisor	\$ 7,364	\$ 7,554	\$ 7,736	\$ 7,928	\$ 8,129	\$ 8,333	\$ 8,540	\$ 8,757	\$ 8,973	\$ 9,198
Senior Accountant	\$ 8,540	\$ 8,757	\$ 8,973	\$ 9,198	\$ 9,426	\$ 9,663	\$ 9,905	\$ 10,154	\$ 10,409	\$ 10,666
Senior Human Resources Analyst	\$ 9,198	\$ 9,426	\$ 9,663	\$ 9,905	\$ 10,154	\$ 10,409	\$ 10,666	\$ 10,934	\$ 11,210	\$ 11,487
Senior Management Analyst	\$ 9,198	\$ 9,426	\$ 9,663	\$ 9,905	\$ 10,154	\$ 10,409	\$ 10,666	\$ 10,934	\$ 11,210	\$ 11,487
Streets Superintendent	\$ 10,666	\$ 10,934	\$ 11,210	\$ 11,487	\$ 11,774	\$ 12,069	\$ 12,371	\$ 12,682	\$ 12,998	\$ 13,322
Transportation Services Manager	\$ 9,198	\$ 9,426	\$ 9,663	\$ 9,905	\$ 10,154	\$ 10,409	\$ 10,666	\$ 10,934	\$ 11,210	\$ 11,487
Utilities Manager	\$ 12,682	\$ 12,998	\$ 13,322	\$ 13,657	\$ 13,997	\$ 14,348	\$ 14,705	\$ 15,076	\$ 15,451	\$ 15,839

Salaries are effective the beginning of the pay period containing July 1, 2026

**EXHIBIT A  
CITY OF ARCADIA MONTHLY SALARY RANGE  
JULY 1, 2024 - JUNE 30, 2025  
SAFETY MANAGEMENT**

Title	Step A	Step B	Step C	Step D	Step E	Step F	Step G	Step H	Step I	Step J
Fire Battalion Chief Police Lieutenant	\$ 15,541	\$ 15,929	\$ 16,328	\$ 16,736	\$ 17,154	\$ 17,583	\$ 18,023	\$ 18,473	\$ 18,935	\$ 19,408
Deputy Fire Chief Police Captain	\$ 17,095	\$ 17,522	\$ 17,960	\$ 18,409	\$ 18,870	\$ 19,341	\$ 19,825	\$ 20,321	\$ 20,829	\$ 21,349

*Salaries are effective the beginning of the pay period containing July 1, 2024*

**EXHIBIT A  
CITY OF ARCADIA MONTHLY SALARY RANGE  
JULY 1, 2025 - JUNE 30, 2026  
SAFETY MANAGEMENT**

<b>Title</b>	<b>Step A</b>	<b>Step B</b>	<b>Step C</b>	<b>Step D</b>	<b>Step E</b>	<b>Step F</b>	<b>Step G</b>	<b>Step H</b>	<b>Step I</b>	<b>Step J</b>
<b>Fire Battalion Chief Police Lieutenant</b>	\$ 16,473	\$ 16,885	\$ 17,307	\$ 17,740	\$ 18,183	\$ 18,638	\$ 19,104	\$ 19,582	\$ 20,071	\$ 20,573
<b>Deputy Fire Chief Police Captain</b>	\$ 18,121	\$ 18,574	\$ 19,038	\$ 19,514	\$ 20,002	\$ 20,502	\$ 21,014	\$ 21,540	\$ 22,078	\$ 22,630

*Salaries are effective the beginning of the pay period containing July 1, 2025*

**EXHIBIT A  
CITY OF ARCADIA MONTHLY SALARY RANGE  
JULY 1, 2026 - JUNE 30, 2027  
SAFETY MANAGEMENT**

<b>Title</b>	<b>Step A</b>	<b>Step B</b>	<b>Step C</b>	<b>Step D</b>	<b>Step E</b>	<b>Step F</b>	<b>Step G</b>	<b>Step H</b>	<b>Step I</b>	<b>Step J</b>
<b>Fire Battalion Chief Police Lieutenant</b>	\$ 17,297	\$ 17,729	\$ 18,173	\$ 18,627	\$ 19,093	\$ 19,570	\$ 20,059	\$ 20,561	\$ 21,075	\$ 21,602
<b>Deputy Fire Chief Police Captain</b>	\$ 19,027	\$ 19,502	\$ 19,990	\$ 20,490	\$ 21,002	\$ 21,527	\$ 22,065	\$ 22,617	\$ 23,182	\$ 23,762

*Salaries are effective the beginning of the pay period containing July 1, 2026*

**EXHIBIT A**  
**CITY OF ARCADIA MONTHLY SALARY RANGE**  
**JULY 1, 2024 - JUNE 30, 2025**  
**UNREPRESENTED**

Title	Step A	Step B	Step C	Step D	Step E	Step F	Step G	Step H	Step I	Step J
<b>Executive Assistant</b>	\$ 6,282	\$ 6,437	\$ 6,599	\$ 6,761	\$ 6,931	\$ 7,105	\$ 7,283	\$ 7,465	\$ 7,651	\$ 7,843
<b>Human Resources Technician</b>	\$ 5,414	\$ 5,551	\$ 5,692	\$ 5,831	\$ 5,979	\$ 6,127	\$ 6,282	\$ 6,436	\$ 6,598	\$ 6,761

*Salaries are effective the beginning of the pay period containing July 1, 2024*

**EXHIBIT A**  
**CITY OF ARCADIA MONTHLY SALARY RANGE**  
**JULY 1, 2025 - JUNE 30, 2026**  
**UNREPRESENTED**

Title	Step A	Step B	Step C	Step D	Step E	Step F	Step G	Step H	Step I	Step J
<b>Executive Assistant</b>	\$ 6,659	\$ 6,823	\$ 6,994	\$ 7,167	\$ 7,347	\$ 7,532	\$ 7,720	\$ 7,913	\$ 8,110	\$ 8,314
<b>Human Resources Technician</b>	\$ 5,739	\$ 5,884	\$ 6,034	\$ 6,180	\$ 6,337	\$ 6,494	\$ 6,659	\$ 6,823	\$ 6,994	\$ 7,167

*Salaries are effective the beginning of the pay period containing July 1, 2025*

**EXHIBIT A  
CITY OF ARCADIA MONTHLY SALARY RANGE  
JULY 1, 2026 - JUNE 30, 2027  
UNREPRESENTED**

<b>Title</b>	<b>Step A</b>	<b>Step B</b>	<b>Step C</b>	<b>Step D</b>	<b>Step E</b>	<b>Step F</b>	<b>Step G</b>	<b>Step H</b>	<b>Step I</b>	<b>Step J</b>
<b>Executive Assistant</b>	\$ 6,992	\$ 7,164	\$ 7,344	\$ 7,525	\$ 7,714	\$ 7,908	\$ 8,106	\$ 8,309	\$ 8,515	\$ 8,730
<b>Human Resources Technician</b>	\$ 6,026	\$ 6,179	\$ 6,335	\$ 6,490	\$ 6,654	\$ 6,819	\$ 6,992	\$ 7,164	\$ 7,343	\$ 7,526

*Salaries are effective the beginning of the pay period containing July 1, 2026*

**Attachment No. 4**

RESOLUTION NO. 7704

A RESOLUTION OF THE CITY COUNCIL OF THE CITY OF ARCADIA, CALIFORNIA, AMENDING RESOLUTION NO. 7594, APPROVING A MEMORANDUM OF UNDERSTANDING ESTABLISHING COMPENSATION AND RELATED BENEFITS FOR EMPLOYEES REPRESENTED BY THE ARCADIA CITY EMPLOYEES' ASSOCIATION ("ACEA") FOR JULY 1, 2024, THROUGH JUNE 30, 2027 (ARBORIST)

WHEREAS, City Council Resolution No. 7594 approved a Memorandum of Understanding ("MOU") by and between the City of Arcadia and the Arcadia City Employees Association ("ACEA") for compensation and related benefits; and

WHEREAS, salaries and benefits for ACEA are adjusted by resolution, which adjustments are then reflected in the City's salary schedule; and

WHEREAS, salary schedules are adopted publicly in accordance with Government Code Section 20636 and Title 2 of the California Code of Regulations Section 570.5 and as required by the California Public Employees' Retirement System ("CalPERS").

NOW THEREFORE, THE CITY COUNCIL OF THE CITY OF ARCADIA, CALIFORNIA, DOES HEREBY FIND, DETERMINE AND RESOLVE AS FOLLOWS:

SECTION 1. Effective upon the beginning of the pay period containing July 1, 2026 (June 28, 2026), the ACEA MOU's Monthly Salary Schedule is amended by adding the position of Arborist to Salary Range No. 56, as set forth in Exhibit "A" attached hereto.

SECTION 2. This Resolution shall become effective upon its adoption.

SECTION 3. The City Clerk shall certify to the adoption of this Resolution.

Passed, approved, and adopted this 16th day of June, 2026.

---

Mayor of the City of Arcadia

ATTEST:

---

City Clerk

APPROVED AS TO FORM:



---

Michael J. Maurer  
City Attorney

**EXHIBIT A**  
**CITY OF ARCADIA MONTHLY SALARY RANGE**  
**JULY 1, 2026 - JUNE 30, 2027**  
**ACEA - 5.0%**

Range Number	Title	Step A	Step B	Step C	Step D	Step E	Step F	Step G	Step H	Step I	Step J
42	Library Assistant	\$ 4,267	\$ 4,372	\$ 4,485	\$ 4,595	\$ 4,710	\$ 4,829	\$ 4,950	\$ 5,076	\$ 5,201	\$ 5,331
43	Accounting Technician I	\$ 4,372	\$ 4,485	\$ 4,595	\$ 4,710	\$ 4,829	\$ 4,950	\$ 5,076	\$ 5,201	\$ 5,331	\$ 5,461
44		\$ 4,485	\$ 4,595	\$ 4,710	\$ 4,829	\$ 4,950	\$ 5,076	\$ 5,201	\$ 5,331	\$ 5,461	\$ 5,600
45	Office Assistant	\$ 4,595	\$ 4,710	\$ 4,829	\$ 4,950	\$ 5,076	\$ 5,201	\$ 5,331	\$ 5,461	\$ 5,600	\$ 5,737
46	Library Technician I Museum Education Coordinator	\$ 4,710	\$ 4,829	\$ 4,950	\$ 5,076	\$ 5,201	\$ 5,331	\$ 5,461	\$ 5,600	\$ 5,737	\$ 5,880
47	Accounting Technician II Senior Citizens Project Specialist	\$ 4,829	\$ 4,950	\$ 5,076	\$ 5,201	\$ 5,331	\$ 5,461	\$ 5,600	\$ 5,737	\$ 5,880	\$ 6,027
48	Library Technician II	\$ 4,950	\$ 5,076	\$ 5,201	\$ 5,331	\$ 5,461	\$ 5,600	\$ 5,737	\$ 5,880	\$ 6,027	\$ 6,178
49	Administrative Assistant City Clerk Technician Senior Citizens Program Specialist	\$ 5,076	\$ 5,201	\$ 5,331	\$ 5,461	\$ 5,600	\$ 5,737	\$ 5,880	\$ 6,027	\$ 6,178	\$ 6,337
50	Building Technician I	\$ 5,201	\$ 5,331	\$ 5,461	\$ 5,600	\$ 5,737	\$ 5,880	\$ 6,027	\$ 6,178	\$ 6,337	\$ 6,491
51	Recreation Coordinator	\$ 5,331	\$ 5,461	\$ 5,600	\$ 5,737	\$ 5,880	\$ 6,027	\$ 6,178	\$ 6,337	\$ 6,491	\$ 6,654
52	Senior Library Technician	\$ 5,461	\$ 5,600	\$ 5,737	\$ 5,880	\$ 6,027	\$ 6,178	\$ 6,337	\$ 6,491	\$ 6,654	\$ 6,820
53	Senior Accounting Technician Utility Billing Specialist	\$ 5,600	\$ 5,737	\$ 5,880	\$ 6,027	\$ 6,178	\$ 6,337	\$ 6,491	\$ 6,654	\$ 6,820	\$ 6,992
54	Building Technician II Senior Administrative Assistant	\$ 5,737	\$ 5,880	\$ 6,027	\$ 6,178	\$ 6,337	\$ 6,491	\$ 6,654	\$ 6,820	\$ 6,992	\$ 7,163
55	Fire Administrative Specialist	\$ 5,880	\$ 6,027	\$ 6,178	\$ 6,337	\$ 6,491	\$ 6,654	\$ 6,820	\$ 6,992	\$ 7,163	\$ 7,345
56	Arborist	\$ 6,027	\$ 6,178	\$ 6,337	\$ 6,491	\$ 6,654	\$ 6,820	\$ 6,992	\$ 7,163	\$ 7,345	\$ 7,525
57	Accounting Specialist Circulation Services Supervisor Revenue Collection Specialist	\$ 6,178	\$ 6,337	\$ 6,491	\$ 6,654	\$ 6,820	\$ 6,992	\$ 7,163	\$ 7,345	\$ 7,525	\$ 7,713
58	Code Services Officer Deputy City Clerk	\$ 6,337	\$ 6,491	\$ 6,654	\$ 6,820	\$ 6,992	\$ 7,163	\$ 7,345	\$ 7,525	\$ 7,713	\$ 7,908
59	Engineering Assistant Historical Museum Curator Information Systems Specialist Librarian I Office Coordinator	\$ 6,491	\$ 6,654	\$ 6,820	\$ 6,992	\$ 7,163	\$ 7,345	\$ 7,525	\$ 7,713	\$ 7,908	\$ 8,106
60	Business License Officer Senior Building Technician	\$ 6,654	\$ 6,820	\$ 6,992	\$ 7,163	\$ 7,345	\$ 7,525	\$ 7,713	\$ 7,908	\$ 8,106	\$ 8,308

**EXHIBIT A**  
**CITY OF ARCADIA MONTHLY SALARY RANGE**  
**JULY 1, 2026 - JUNE 30, 2027**  
**ACEA - 5.0%**

Range Number	Title	Step A	Step B	Step C	Step D	Step E	Step F	Step G	Step H	Step I	Step J
61		\$ 6,820	\$ 6,992	\$ 7,163	\$ 7,345	\$ 7,525	\$ 7,713	\$ 7,908	\$ 8,106	\$ 8,308	\$ 8,516
62	Public Works Inspector Senior Code Services Officer	\$ 6,992	\$ 7,163	\$ 7,345	\$ 7,525	\$ 7,713	\$ 7,908	\$ 8,106	\$ 8,308	\$ 8,516	\$ 8,730
63		\$ 7,163	\$ 7,345	\$ 7,525	\$ 7,713	\$ 7,908	\$ 8,106	\$ 8,308	\$ 8,516	\$ 8,730	\$ 8,947
64	Assistant City Clerk Assistant Planner Building Inspector Librarian II Senior Engineering Assistant	\$ 7,345	\$ 7,525	\$ 7,713	\$ 7,908	\$ 8,106	\$ 8,308	\$ 8,516	\$ 8,730	\$ 8,947	\$ 9,170
65		\$ 7,525	\$ 7,713	\$ 7,908	\$ 8,106	\$ 8,308	\$ 8,516	\$ 8,730	\$ 8,947	\$ 9,170	\$ 9,403
66	Senior Public Works Inspector	\$ 7,713	\$ 7,908	\$ 8,106	\$ 8,308	\$ 8,516	\$ 8,730	\$ 8,947	\$ 9,170	\$ 9,403	\$ 9,636
67		\$ 7,908	\$ 8,106	\$ 8,308	\$ 8,516	\$ 8,730	\$ 8,947	\$ 9,170	\$ 9,403	\$ 9,636	\$ 9,878
68	Fire Prevention Specialist Public Works Customer Service/Administrative Supervisor Code Services Supervisor	\$ 8,106	\$ 8,308	\$ 8,516	\$ 8,730	\$ 8,947	\$ 9,170	\$ 9,403	\$ 9,636	\$ 9,878	\$ 10,124
69	Assistant Engineer Associate Planner Senior Building Inspector Plans Examiner	\$ 8,308	\$ 8,516	\$ 8,730	\$ 8,947	\$ 9,170	\$ 9,403	\$ 9,636	\$ 9,878	\$ 10,124	\$ 10,377
70		\$ 8,516	\$ 8,730	\$ 8,947	\$ 9,170	\$ 9,403	\$ 9,636	\$ 9,878	\$ 10,124	\$ 10,377	\$ 10,638
71	Senior Fire Prevention Specialist	\$ 8,730	\$ 8,947	\$ 9,170	\$ 9,403	\$ 9,636	\$ 9,878	\$ 10,124	\$ 10,377	\$ 10,638	\$ 10,905
72		\$ 8,947	\$ 9,170	\$ 9,403	\$ 9,636	\$ 9,878	\$ 10,124	\$ 10,377	\$ 10,638	\$ 10,905	\$ 11,173
73	Principal Librarian	\$ 9,170	\$ 9,403	\$ 9,636	\$ 9,878	\$ 10,124	\$ 10,377	\$ 10,638	\$ 10,905	\$ 11,173	\$ 11,451
74	Associate Civil Engineer	\$ 9,401	\$ 9,634	\$ 9,874	\$ 10,123	\$ 10,375	\$ 10,633	\$ 10,901	\$ 11,173	\$ 11,451	\$ 11,739
75	Senior Planner	\$ 9,634	\$ 9,874	\$ 10,123	\$ 10,375	\$ 10,633	\$ 10,901	\$ 11,173	\$ 11,451	\$ 11,739	\$ 12,033
76		\$ 9,874	\$ 10,123	\$ 10,375	\$ 10,633	\$ 10,901	\$ 11,173	\$ 11,451	\$ 11,739	\$ 12,033	\$ 12,333
77		\$ 10,123	\$ 10,375	\$ 10,633	\$ 10,900	\$ 11,174	\$ 11,451	\$ 11,738	\$ 12,033	\$ 12,333	\$ 12,641
78	Senior Civil Engineer	\$ 10,375	\$ 10,634	\$ 10,901	\$ 11,173	\$ 11,452	\$ 11,738	\$ 12,032	\$ 12,333	\$ 12,640	\$ 12,958

Salaries are effective the beginning of the pay period containing July 1, 2026  
Arborist added and approved 06/16/2026, effective the beginning of the pay period containing 7/01/2026

## **CITY OF ARCADIA**

### **ASSISTANT CITY MANAGER/PUBLIC WORKS SERVICES DIRECTOR**

#### **DEFINITION**

Under general administrative direction, to plan, direct, manage, and oversee the activities and operations of the Public Works Services Department including streets, water, engineering, sanitation, facilities, and contract services; to coordinate assigned activities with other City departments and outside agencies; and to provide highly responsible and complex administrative support to the City Manager; to serve as Assistant City Manager; and may serve as City Manager in the absence of the City Manager.

#### **SUPERVISION EXERCISED**

Exercises direct supervision over management, supervisory, professional, technical, and clerical staff.

#### **EXAMPLES OF IMPORTANT AND ESSENTIAL DUTIES**

Serve as Acting City Manager in the City Manager's absence and make administrative decisions as necessary; provide advice and assistance to the City Council, the public, and other agencies; respond to inquiries and provide information regarding City policies, procedures, and operations.

Provide insights and strategic advice to the City Manager regarding policies and direction of the City as a whole.

Assist the City Manager with the development and implementation of City policies and overall operation of the City through direction, support, and guidance of City departments.

Provide leadership for the development of a shared vision, strategy, policy, and goals for all City activities and operations.

Participate in negotiation process with the City's bargaining groups; work with the City Council, City Manager, Human Resources Director, Administrative Services Director, and the City's bargaining units in maintaining decorum throughout the negotiation process.

Serve as project manager or city liaison for Citywide projects of a sensitive or time-restricted nature as directed by the City Manager.

Coordinate activities of the City Manager's Office with other City departments and with outside agencies as directed by the City Manager.

Assume full management responsibility for all Public Works Services Department services and activities including streets, water, engineering, sanitation, facilities, fleet, wastewater and contract services.

Manage the development and implementation of Public Works Services Department goals, objectives, policies, and priorities for each assigned service area; establish, within City policy, appropriate service and staffing levels; allocate resources accordingly.

Continuously monitor and evaluate the efficiency and effectiveness of service delivery methods and procedures; assess and monitor workload, administrative and support systems, and internal reporting relationships; identify opportunities for improvement; direct the implementation of changes.

Represent the Public Works Services Department to other City departments, elected officials and outside agencies; explain and interpret Public Works Services Department programs, policies, and activities; negotiate and resolve sensitive, significant, and controversial issues.

Select, train, motivate, and evaluate Public Works Services Department personnel; provide or coordinate staff training; work with employees to correct deficiencies; implement discipline and termination procedures.

Plan, direct, and coordinate the Public Works Services Department's work plan; meet with management staff to identify and resolve problems; assign projects and programmatic areas of responsibility; review and evaluate work methods and procedures.

Manage and participate in the development and administration of the Public Works Services Department budget; direct the forecast of additional funds needed for staffing, equipment, materials, and supplies; direct the monitoring of and approve expenditures; direct the preparation of and implement budgetary adjustments as necessary.

Direct and coordinate the design of public utility systems, public works projects and facilities; oversee contract City Engineer services in the approval of plans and specifications; oversee construction activities and related department services.

Oversee the administration and coordination of the National Pollutant Discharge Elimination System (NPDES) Program to ensure continual compliance.

Coordinate the preparation of the 5-year capital improvement and equipment replacement budgets for all City departments and present to City Council.

Direct the administration of the waste management, refuse and recycling contract for residential refuse collection; monitor commercial hauling and ensure City compliance with AB939 requirements.

Negotiate contract extensions, amendments, and related changes for contract services.

Coordinate Public Works Services Department activities with those of other departments and outside agencies and organizations.

Provide staff assistance to the City Manager and City Council; prepare and present staff reports and other necessary correspondence.

Conduct a variety of organizational studies, investigations, and operational studies; recommend modifications to Public Works Services programs, policies, and procedures as appropriate.

Participate on a variety of boards and commissions; attend and participate in professional group meetings; stay abreast of new trends and innovations in the field of public works.

Respond to and resolve difficult and sensitive inquiries and complaints.

### **OTHER JOB RELATED DUTIES**

Perform related duties and responsibilities as assigned.

### **JOB RELATED AND ESSENTIAL QUALIFICATIONS**

#### **Knowledge of:**

Operations typical of local government services such as budgeting and financial services, human resources, recreation, community services, library services, communications, public safety, water utility, and more.

General executive management principles and methods including goal setting, program development and implementation, project management and budgeting.

Public policy, City functions and activities, local government practices, administration, political dynamics, and community needs.

Operational characteristics, services, and activities of a comprehensive public works program.

Organization and management practices as applied to the analysis and evaluation of programs, policies, and operational needs.

Modern and complex principles and practices of program development and administration.

Advanced principles and practices of municipal budget preparation and administration.

Principles of supervision, training, and performance evaluation.

Pertinent Federal, State, and local laws, codes, and regulations.

Safe driving principles and practices.

**Skill to:**

Operate modern office equipment including computer equipment.

Operate a motor vehicle safely.

**Ability to:**

Assist the City Manager in managing overall City operations.

Understand, interpret, and lead the implementation of City Council goals, policies, and directives.

Coordinate and direct a variety of complex assignments and make decisions rapidly within the scope of authority and recommended solutions.

Communicate effectively and diplomatically with the City Council, community, public and private organizations, community stakeholders, boards and commissions, and City staff at all levels in the organization.

Provide administrative and professional leadership and direction for the Public Works Services Department.

Develop, implement, and administer goals, objectives, and procedures for providing effective and efficient public works services.

Plan, organize, direct, and coordinate the work of management, supervisory, professional, technical, and clerical personnel; delegate authority and responsibility.

Select, supervise, train, and evaluate staff.

Identify and respond to community and City Council issues, concerns, and needs.

Analyze problems, identify alternative solutions, project consequences of proposed actions, and implement recommendations in support of goals.

Research, analyze, and evaluate new service delivery methods, procedures, and techniques.

Prepare and administer large and complex budgets; allocate limited resources in a cost effective manner.

Prepare clear and concise administrative and financial reports.

Interpret and apply the policies, procedures, laws, codes, and regulations pertaining to assigned programs and functions.

Communicate clearly and concisely, both orally and in writing.

Establish, maintain, and foster positive and harmonious working relationships with those contacted in the course of work.

**Minimum Qualifications:**

Any combination of education and experience that would provide the required knowledge, skills and abilities is qualifying. The incumbent will possess the most desirable combination of training, skills, and experience, as demonstrated in past and current employment history. A typical way to achieve this is:

**Experience:**

Seven years of responsible public works experience including five years of supervisory experience over subordinate staff in a management position, and at least one year of experience as Assistant to the City Manager or similar.

**Training:**

Equivalent to a Bachelor's Degree from an accredited college or university with major course work in engineering, public administration, or a related field. A Master's degree is highly desirable.

**License or Certificate:**

Possession of, or ability to obtain, an appropriate, valid driver's license.

**Special Requirements:**

*Essential duties require the following physical skills and work environment:*

Ability to work in a standard office environment; ability to travel to different sites and locations.

**Effective Date:** January, 1999

**Revised:** October 2020; July 2026

## **CITY OF ARCADIA**

### **CITY ENGINEER/DEPUTY PUBLIC WORKS SERVICES DIRECTOR**

#### **DEFINITION**

Under general administrative direction, to plan, direct, manage and oversee activities and services of the Engineering, Traffic Engineering and Streets Sections of the Public Works Services Department. The City Engineer provides technical review and approval of planning reports, design plans, specifications, contracts and construction engineering of the City's infrastructure assets; for programs and projects administered by the Engineering Section. Typical infrastructure programs include: development engineering and review, traffic and transportation engineering, capital improvement program implementation, master planning and assigned activities with other departments, divisions, consultants, contractors, engineers and outside agencies; and to provide highly responsible and complex administrative support to the Assistant City Manager/Public Works Services Director.

#### **SUPERVISION EXERCISED**

Exercises direct supervision over management, supervisory, professional, technical and clerical staff.

#### **EXAMPLES OF IMPORTANT AND ESSENTIAL DUTIES**

Assume management responsibility for all activities in Engineering, Traffic Engineering, and Street Sections. Manage and participate in the development and implementation of goals, objectives, policies and priorities with direct management responsibility for the Engineering, Traffic Engineering, and Streets Sections of the Public Works Services Department.

#### **Public Works Services Department – Engineering**

Recommend in accordance with City policy, appropriate service and staffing levels; recommend and administer policies and procedures.

Continuously monitor and evaluate the efficiency and effectiveness of service delivery methods and procedures; assess and monitor workload, administrative and support systems, and internal reporting relationships; identify opportunities for improvement and review with the Assistant City Manager/Public Works Services Director.

Select, train, motivate, and evaluate assigned personnel; provide or coordinate staff training; work with employees to correct deficiencies; implement discipline and termination procedures

Responsible for the day to day administration of the Engineering, Traffic Engineering, and Streets Sections' operational budget; forecast funds needed for staffing, equipment, materials and supplies; approve budgeted expenditures; conduct monthly budget reviews

of operational and capital improvement program budgets; direct the preparation of annual operational and capital improvement budgets.

Plan, direct, coordinate and review the work plan for the Engineering Section, Traffic Engineering, and Streets Section; meet with staff to identify and resolve problems; assign work activities, projects and programs; monitor workflow; review and evaluate work products, methods and procedures.

Respond to and resolve difficult and sensitive citizen inquiries and complaints.

Administer Subdivision Map Act requirements for development.

Approves Tract and Parcel Maps.

Responsible for oversight of conditions of approval on development projects.

Provides technical oversight for inspection of private improvement projects in public right of way.

### **Capital Improvement Program**

Provides technical review and approvals for capital improvement projects under the direction of the Assistant City Manager/ Public Works Services Director for each respective CIP program.

Assist the Assistant City Manager/Public Works Services Director in maximizing the use of outside funding sources such as federal, state, regional and sub-regional for capital programs.

Provides technical review of the planning, design, construction and administration of assessment district proceedings.

Oversees the planning, design and construction of cooperative projects undertaken with adjoining jurisdictions and other agencies such as Caltrans, LA County Department of Public Works, MTA or others.

Prepare and negotiates cooperative agreements with other jurisdictions and agencies for cooperative projects.

### **Technical Consultation**

Provides in-house professional engineering consultation to the Assistant City Manager/Public Works Services Director and to the City Manager and City Attorney offices as required. Prepare and present staff reports and other necessary correspondence.

Conduct a variety of organizational studies, investigations and operational studies; recommend modifications to division programs, policies and procedures as appropriate.

### **OTHER JOB RELATED DUTIES**

Perform related duties and responsibilities as assigned.

### **JOB RELATED AND ESSENTIAL QUALIFICATIONS**

#### **Knowledge of:**

Principles and practices of management, civil engineering, transportation and transit, and administration.

Organizational and management practices as applied to the analysis and evaluation of engineering programs, policies and operational needs.

Modern and complex principles of engineering program development, building construction, code enforcement, and administration.

Recent developments, current literature and sources of information regarding civil engineering and land surveying.

Principles and practices of supervision, training and performance evaluation.

Pertinent Federal, State and local laws, codes and regulations.

#### **Skill to:**

Operate modern computer equipment and utilize office based software applications.

Operate a motor vehicle.

#### **Ability to:**

Act effectively as a member of an interdisciplinary team with the Public Works Services Department and with other Departments within the City.

Manage, direct and coordinate the work of supervisory, professional and technical personnel.

Select, supervise, train and evaluate staff.

Provide administrative and professional leadership and direction to the Engineering, Traffic Engineering, and Streets Section.

Recommend and implement goals, objectives, and practices for providing effective and efficient engineering services.

Prepare and administer the division budget.

Prepare clear and concise administrative and financial reports.

Analyze problems, identify alternative solutions, project consequences of proposed actions and implement recommendations in support of goals.

Research, analyze, and evaluate new service delivery methods, procedures and techniques.

Interpret and apply Federal, State and local policies, procedures, laws and regulations.

Communicate clearly and concisely, both orally and in writing.

Establish, maintain and foster positive and harmonious working relationships with those contacted in the course of work.

## **EXPERIENCE AND TRAINING GUIDELINES**

Any combination of education and/or experience that provides the required knowledge, skills, and abilities to perform the essential job duties of the position is qualifying. The incumbent will possess the most desirable combination of training, skills, and experience, as demonstrated in past and current employment history. A typical example includes:

### **Experience:**

Six (6) years of increasingly responsible professional civil engineering experience including two years of supervisory and administrative responsibility.

### **Training:**

Equivalent to a Bachelor's degree from an accredited college and university with major course work in civil engineering or closely related field.

### **License or Certificate:**

Possession of an appropriate, valid Certificate of Registration as a Professional Civil Engineer issued by the California State Board of Registration for Professional Engineers. A valid Certificate of registration as a Land Surveyor in California is desirable if the candidate's Civil Engineering license is post 1982.

Possession of or ability to obtain a valid drivers license.

**Special Requirements:**

Ability to work in a standard office environment; ability to travel to different sites and locations.

**Effective Date:** February 2008

**Revised Date:** August 2017; December 2022; July 2026

## **CITY OF ARCADIA**

### **DEPUTY PUBLIC WORKS SERVICES DIRECTOR - ADMINISTRATION**

#### **DEFINITION**

Under administrative direction, to direct, manage, supervise, and coordinate the programs and activities in the Customer Service Section, Environmental Services Section, and General Services Section, including the construction and maintenance of street lights, fleet maintenance, building maintenance, sewer, water, and storm drain systems, park and outdoor facility maintenance, contract administration and customer service; to coordinate assigned activities with other City departments, divisions, and outside agencies; and to provide highly responsible and complex administrative support to the Assistant City Manager/Public Works Services Director.

#### **SUPERVISION EXERCISED**

Exercises direct supervision over supervisory, professional, technical, and clerical staff.

#### **EXAMPLES OF IMPORTANT AND ESSENTIAL DUTIES**

Assume management responsibility for all activities in the assigned sections, including Customer Services, Environmental Services, and General Services.

Manage and participate in the development and implementation of goals, objectives, policies, and priorities for assigned programs including the construction and maintenance of street lights and signal maintenance storm drain systems, park and outdoor facility maintenance, fleet and building maintenance, contract administration, and customer service activities; recommend, within Departmental policy, appropriate service and staffing levels; recommend and administer policies and procedures.

Continuously monitor and evaluate the efficiency and effectiveness of service delivery methods and procedures; assess and monitor workload, administrative and support systems, and internal reporting relationships; identify opportunities for improvement and review with the Assistant City Manager/Public Works Services Director; direct the implementation of improvements.

Select, train, motivate, and evaluate assigned personnel; provide or coordinate staff training; work with employees to correct deficiencies; implement discipline and termination procedures.

Plan, direct, coordinate, and review the work plan for assigned sections; meet with staff to identify and resolve problems; assign work activities, projects, and programs; monitor work flow; review and evaluate work products, methods, and procedures.

### **EXAMPLES OF IMPORTANT AND ESSENTIAL DUTIES**

Manage and participate in the development and administration of the Customer Services, Environmental Services, and General Services annual budget; direct the forecast of additional funds needed for staffing, equipment, materials, and supplies; direct the monitoring of and approve expenditures; direct and implement adjustments as necessary.

Serve as a liaison for the department with other City departments, divisions, and outside agencies; negotiate and resolve significant and controversial issues.

Monitor all phases of contract administration and management of the Par 3 golf course contract.

Direct customer service activities such as service installations, meter reading, and responses to customer requests for services.

Monitor water conservation efforts and compliance with state regulations for water use.

Prepare estimates and monitor construction, maintenance and operating costs.

Evaluate service and equipment needs; write or review bid specifications; monitor contractor/equipment performance.

Review and investigate citizen complaints and requests and determine and ensure appropriate disposition.

Monitor work completed in response to concerns from the City Council and the City Manager.

Investigate and report on matters related to claims made against the City.

Inspect work in progress to ensure compliance with City specifications.

Participate on a variety of boards and commissions; attend and participate in professional group meetings; stay abreast of new trends and innovations in the field of engineering, construction, and maintenance services.

Provide responsible staff assistance to the Assistant City Manager/Public Works Services Director; prepare and present staff reports and other necessary correspondence.

Conduct a variety of organizational studies, investigations, and operational studies; recommend modifications to Customer Services, Environmental Services, and General Services programs, policies, and procedures as appropriate.

Respond to and resolve difficult and sensitive inquiries and complaints.

Serve as the department head in the absence of the Assistant City Manager/Public Works Services Director.

Supervise staff in the maintenance and repairs of buildings, street lighting, and fleet vehicles and equipment.

### **OTHER JOB RELATED DUTIES**

Perform related duties and responsibilities as assigned.

### **JOB RELATED AND ESSENTIAL QUALIFICATIONS**

#### **Knowledge of:**

Operational characteristics, services, and activities of engineering, construction, and maintenance programs.

Methods, practices, materials, tools and equipment used in the construction and maintenance of street, sewer, water and storm drain systems, and park and outdoor facility maintenance.

Information sources and research techniques in the areas of construction, street and building maintenance, park maintenance, and sewer, water and storm drains.

Construction safety methods and practices.

Organizational and management practices as applied to the analysis and evaluation of Field Services programs, policies, and operational needs.

Modern and complex principles and practices of program development and administration.

Advanced principles and practices of budget preparation and administration.

Principles of supervision, training, and performance evaluation.

Pertinent Federal, State, and local laws, codes, and regulations.

Safe driving principles and practices.

**Skill to:**

Operate modern office equipment including computer equipment.

Operate a motor vehicle safely.

**Ability to:**

Provide administrative and professional leadership and direction for the Customer Services, Environmental Services, and General Services Sections.

Recommend and implement goals, objectives, and practices for providing effective and efficient programs and services.

Manage, direct, and coordinate the work of supervisory, professional, technical, and clerical personnel.

Select, supervise, train, and evaluate staff.

Instruct skilled and semi-skilled workers in the methods, practices, tools, and equipment used in the construction and maintenance of street, sewer, water and storm drain systems and park and outdoor facility maintenance.

Maintain records of time, materials, and equipment.

Identify and respond to community issues, concerns, and needs.

Analyze problems, identify alternative solutions, project consequences of proposed actions, and implement recommendations in support of goals.

Research, analyze, and evaluate new service delivery methods, procedures, and techniques.

Prepare and administer budgets.

Prepare clear and concise administrative and financial reports.

Interpret and apply the policies, procedures, laws, codes, and regulations pertaining to assigned programs and functions.

Communicate clearly and concisely, both orally and in writing.

Establish, maintain, and foster positive and harmonious working relationships with those contacted in the course of work.

**Minimum Qualifications:**

Any combination of education and experience that provides the required knowledge, skills, and abilities to perform the essential job duties of the position is qualifying. The incumbent will possess the most desirable combination of training, skills, and experience, as demonstrated in his/her past and current employment history. A typical example includes:

**Experience:**

Six years of responsible experience in the construction and maintenance of public works including four years of management and supervisory experience. Experience in utilities management is desirable.

**Training:**

Equivalent to a Bachelor's degree from an accredited college or university with major course work in public administration, engineering, or a related field.

**License or Certificate:**

Possession of, or ability to obtain, an appropriate, valid driver's license.

**Special Requirements:**

*Essential duties require the following physical skills and work environment:*

Ability to work in a standard office environment; ability to travel to different sites and locations.

**Effective Date:** March 2006

**Revised:** February 2022; July 2026

## **CITY OF ARCADIA**

### **UTILITIES MANAGER**

#### **DEFINITION**

Under administrative direction, to direct, manage, supervise, and coordinate the programs and activities of the Utilities Section of the Public Works Services Department; to coordinate assigned activities with other City departments, divisions, and outside agencies; and to provide highly responsible and complex administrative support to the Assistant City Manager/Public Works Services Director.

#### **SUPERVISION EXERCISED**

Exercises direct supervision over supervisory, technical, and maintenance staff.

#### **EXAMPLES OF IMPORTANT AND ESSENTIAL DUTIES**

Assume management responsibility for all water and sewer services and activities. Assist in managing and overseeing water and sewer engineering projects.

Manage and participate in the development and implementation of goals, objectives, policies, and priorities for assigned Utilities Section programs including construction, maintenance, operation, and emergency disaster response; recommend, within Departmental policy, appropriate service and staffing levels; recommend and administer policies and procedures.

Continuously monitor and evaluate the efficiency and effectiveness of service delivery methods and procedures; assess and monitor workload, administrative and support systems, and internal reporting relationships; identify opportunities for improvement and review with the Assistant City Manager/Public Works Services Director; direct the implementation of improvements.

Select, train, motivate, and evaluate assigned personnel; provide or coordinate staff training; work with employees to correct deficiencies; implement discipline and termination procedures.

Plan, direct, coordinate, and review the work plan for the Utilities Section; meet with staff to identify and resolve problems; assign work activities, projects, and programs; monitor workflow; review and evaluate work products, methods, and procedures.

Manage and participate in the development and administration of the Utilities Sections annual budgets; direct the forecast of additional funds needed for staffing, equipment, materials, and supplies; direct the monitoring of and approve expenditures; direct and implement adjustments as necessary.

Serve as a liaison for the Utilities Section with other City departments, divisions, and outside agencies; negotiate and resolve significant and controversial issues.

Prepare estimates and monitor construction, maintenance, and operating costs.

### **EXAMPLES OF IMPORTANT AND ESSENTIAL DUTIES**

Approve utility drawings submitted to the Engineering Section and assist the Engineering Section in the preparation and review of plans, specifications, and drawings.

Direct sanitary sewer and stormdrain maintenance programs. Sanitary Sewer Overflow compliance and monthly reporting.

Plan, coordinate, direct, supervise, and inspect the maintenance of sanitary sewers.

Assist in preparing annual consumer confidence report.

Assist in preparing quarterly water facility treatment report.

Conduct annual water system inspection with the State Health Department.

Assist with preparation of application for NPDES permits and required follow-up reports with the Regional Water Quality Control Board.

Provide responsible staff assistance to the Assistant City Manager/Public Works Services Director; prepare and present staff reports and other necessary correspondence.

Conduct a variety of organizational studies, investigations, and operational studies; recommend modifications to the Utilities Sections programs, policies, and procedures as appropriate.

Periodically field check work in progress and upon completion; make field inspections of water/sanitary sewer systems; note and take proper action to correct defects.

Make public notification of water supply contamination in accordance with the City's policy and State Water Resources Control Board Division of Drinking Water requirements; notify appropriate personnel, agencies, and authorities of water supply contamination; inspect contaminated areas; determine appropriate corrective measures; obtain authorization to return to normal operations.

Estimate cost of proposed construction projects; confer with consultant engineers and

contractors on construction projects.

In the event of emergencies and disasters, implement the City's emergency disaster plans; conduct inspections to assess damage and corrective action needed.

Participate on a variety of boards and commissions; attend and participate in professional group meetings; stay abreast of new water basin trends, state contaminant regulations, and innovations in the field of water/sanitary sewer systems.

Respond to and resolve difficult and sensitive inquiries and complaints.

### **OTHER JOB RELATED DUTIES**

Perform related duties and responsibilities as assigned.

### **JOB RELATED AND ESSENTIAL QUALIFICATIONS**

#### **Knowledge of:**

Operational characteristics, services, and activities of a water distribution/production and sanitary sewer programs.

Practices, methods, equipment, tools, and materials used in water distribution and sanitary sewer systems service, installation, construction, maintenance, and operation.

Principles of hydraulics.

Occupational hazards and standard safety practices necessary in the area of water distribution/production.

Organizational and management practices as applied to the analysis and evaluation of programs, policies, and operational needs.

Modern and complex principles and practices of program development and administration.

Advanced principles and practices of budget preparation and administration.

Principles of supervision, training, and performance evaluation.

Pertinent Federal, State, and local laws, codes, and regulations.

Principles of record keeping and report preparation.

Techniques used in public relations.

Principles of mathematics.

Safe driving principles and practices.

**Skill to:**

Operate a variety of vehicles, equipment, and tools used in the operation, construction, and maintenance of a water distribution and sanitary sewer systems.

Operate modern office equipment including computer equipment.

Operate a motor vehicle safely.

**Ability to:**

Provide administrative and professional leadership and direction for the Utilities Section including construction, maintenance, and operations.

Recommend and implement goals, objectives, and practices for providing effective and efficient water distribution/production and sanitary sewer facilities.

Manage, direct, and coordinate the work of supervisory, technical, and maintenance personnel.

Select, supervise, train, and evaluate staff.

Identify and respond to community issues, concerns, and needs.

Analyze problems, identify alternative solutions, project consequences of proposed actions, and implement recommendations in support of goals.

Research, analyze, and evaluate new service delivery methods, procedures, and techniques.

Prepare and administer budgets.

Read, interpret, and apply a wide variety of technical information from manuals, drawings, specifications, layouts, blueprints, and schematics.

Prepare and maintain accurate and complete records.

Prepare clear and concise reports.

Perform accurate mathematical computations.

Act quickly and calmly in emergencies.

Interpret and apply the policies, procedures, laws, and regulations pertaining to assigned programs and functions.

**Ability to:**

Exercise good judgment, flexibility, creativity, and sensitivity in response to changing situations and needs.

Communicate clearly and concisely, both orally and in writing.

Establish, maintain, and foster positive and harmonious working relationships with those contacted in the course of work.

**Minimum Qualifications:**

**Experience:**

Six years of responsible experience in the operation, maintenance, and construction of water and sanitary sewer systems including four years of management and supervisory experience.

**Training:**

Equivalent to an Associate's degree with major course work in water technology or a related field. A Bachelor's degree in public administration, business management or a related field highly desirable.

**License or Certificate:**

Possession of, or ability to obtain, a valid class “C” driver's license.

Possession of a Water Distribution Operator, Grade IV Certificate issued by the California Water Resources Control Board Division of Drinking Water.

Possession of a Water Treatment Operator, Grade III Certificate issued by the California Water Resources Control Board Division of Drinking Water.

**Special Requirements:**

*Essential duties require the following physical skills and work environment:*

Ability to work in a standard office environment with some exposure to outdoors, mechanical hazards, electrical hazards, and traffic hazards; ability to travel to different sites and locations.

**Effective Date:** June, 2003

**Revised Date:** November 2016; July 2026

## **CITY OF ARCADIA**

### **CITY ARBORIST**

#### **DEFINITION**

Under the direct supervision of the Administration/Deputy Public Works Services Director, the City Arborist plans, develops, coordinates, and directs the City's tree, park-strip, and landscape maintenance programs and contracts. The City Arborist provides technical expertise and training related to tree maintenance, preservation, and urban forestry activities, including median landscaping, weed abatement, insect and disease control, and landscape assessment district programs. Responsibilities include, but are not limited to, overseeing and coordinating the work of contractors and City staff related to tree-maintenance activities; investigating and resolving tree and landscape-related issues in the City while enforcing and ensuring compliance with City policies, ordinances, and standards; coordinating tree-trimming activities with City departments and divisions; and inspecting and monitoring projects involving protected trees on development sites. The City Arborist must have technical knowledge and training related to tree-maintenance.

#### **SUPERVISION EXERCISED**

Exercises direct supervision over contractors and provides technical direction, training, and oversight to City staff and maintenance crews engaged in tree maintenance, preservation, and related landscape activities.

#### **EXAMPLES OF IMPORTANT AND ESSENTIAL DUTIES**

Develop, coordinate, and manage the City's tree maintenance, preservation, and urban forestry programs and projects.

Develop annual work plans, performance measures, and levels of service related to tree care and landscape maintenance.

Assign, instruct, supervise, review, and approve the work of contracted tree maintenance providers and City staff engaged in tree maintenance, landscape maintenance, weed abatement, and pest control activities.

Review service requests and respond to inquiries, complaints, and concerns related to trees, park-strip landscaping, and City-maintained landscape areas.

Serve as technical and resource support for City staff, contractors, residents, and developers regarding tree maintenance, preservation, tree-related view issues, tree trimming, tree removal, and applicable City standards and ordinances.

Collaborate on the development and implementation of tree pest and disease prevention, monitoring, and management programs.

Review plans, specifications and work sites for landscape rehabilitation projects and development activities involving protected trees.

Develop, maintain, and analyze tree inventory records, planting-related performance measures, maintenance schedules, and related databases.

Use computerized maintenance management systems, such as Tyler Enterprise Asset Management or similar, to support tree management and maintenance activities.

Coordinate tree trimming, planting, maintenance, and preservation activities with contractors, City departments, utility providers, and outside agencies.

Track and analyze data; prepare technical reports, correspondence, and recommendations; and present findings to City management, commissions, and/or City Council as needed.

Assist in the preparation and administration of annual operating budgets related to tree maintenance, landscaping, and associated contracts.

Inspect City trees, medians, park-strips, and development sites to evaluate tree health, safety, maintenance needs, code compliance, and protected tree conditions.

Attend evening or weekend meetings as required.

Conduct field visits and inspections.

Receive calls for emergency services and be available to respond during non-scheduled work hours, including evenings, holidays and weekends

Investigate landscape and tree-related issues and enforce compliance with applicable City policies, ordinances, permits, and standards in a professional and diplomatic manner.

### **OTHER JOB RELATED DUTIES**

Perform related duties and responsibilities as assigned.

### **JOB RELATED AND ESSENTIAL QUALIFICATIONS**

#### **Knowledge of:**

Principles, practices, methods, techniques, materials, and equipment used in arboriculture, urban forestry, tree maintenance, preservation, planting, and pest management.

Tree species identification; tree health assessment; insect, disease, and weed control methods commonly found in Southern California landscapes.

Applicable federal, state, and local laws, regulations, ordinances, and standards related to tree maintenance, protected trees, landscape maintenance, pesticide application, and public safety.

Methods and practices related to median landscaping, park-strip maintenance, weed abatement, irrigation, and landscape assessment district programs.

Contract administration, inspection procedures, and performance monitoring related to tree maintenance and landscape service contracts.

Principles of supervision, training, and work coordination.

Budgeting, project planning, scheduling, recordkeeping, and report preparation.

Computer applications including Microsoft Office Suite, computerized maintenance management systems, and related technologies.

**Skill to:**

Communicate clearly and concisely, both orally and in writing.

Apply tree maintenance policies and standards.

Adaptability/Dealing with Ambiguity.

Presentation Skills.

Decision Making.

Prioritize work and meet deadlines.

Work independently with minimal supervision.

**Ability to:**

Establish, maintain, and foster effective, positive, and harmonious working relationships with those contacted in the course of work, such as contractors, consultants, community groups, the public, co-workers, subordinates, supervisors, etc.

Foster a teamwork environment.

Manage multiple tree maintenance, preservation, and landscape projects concurrently from initiation through completion.

Coordinate and prioritize field operations, inspections, and maintenance activities to ensure timely completion of tree and landscape work.

Maintain records and prepare reports.

Supervise, train, and evaluate staff.

Provide clear direction to contractors and staff to ensure work is completed in accordance with City standards, specifications, and safety requirements.

**Minimum Qualifications:**

Any combination of education and/or experience that provides the required knowledge, skills, and abilities to perform the essential job duties of the position is qualifying. The incumbent will possess the most desirable combination of training, skills, and experience, as demonstrated in past and current employment history. A typical example includes:

**Experience/Training:**

Three (3) years minimum professional experience managing tree and insect disease control and tree planting, preservation, and maintenance activities. Landscape maintenance knowledge is desired.

**Education:**

Associate's degree in business, business administration, horticulture, urban forestry, or a closely related field.

Bachelor's degree in the above fields is highly desirable.

**License or Certificate:**

Possession of a valid Arborist Certification from the International Society of Arboriculture (ISA) is required at the time of appointment and must be maintained throughout the course of employment.

Due to the performance of field duties that will require the operation of a City vehicle, a valid California Class C Driver's license and an acceptable driving record are required.

**Special Requirements:**

*Essential duties require the following physical abilities and work environment:*

Ability to work in a standard office environment; ability to travel to different sites and locations.

**Effective Date:** July 2026